FM 71-100-2

**INFANTRY DIVISION
OPERATIONS**

**TACTICS,
TECHNIQUES,
AND
PROCEDURES**

Headquarters, Department of the Army

DISTRIBUTION RESTRICTION: Approved for publication release; distribution is unlimited.

CONTENTS

	<i>Page</i>
Preface	i
Contents	ii
Introduction	v
Chapter 1. Light, Air Assault, and Airborne Infantry Divisions	1-1
Light Infantry Division	1-1
Air Assault Division	1-1
Airborne Division	1-3
Chapter 2. Command and Control	2-1
Section I. Command and Control Fundamentals	2-1
Command and Control Guidelines	2-1
Command Post Relationships	2-1
Section II. Command Post Operations and Techniques	2-3
Alternate Command Post	2-3
Command Post Personnel	2-4
Information Management	2-5
Planning	2-8
Rehearsals	2-10
Continuous Operations	2-12
Liaison Operations	2-15
Command Post Displacement	2-18
Command Post Security	2-19
Section III. Command Post Facilities	2-19
The Tactical Command Post	2-20
The Main Command Post	2-31
The Rear Command Post	2-61
The Assault Command Post	2-80
Chapter 3. Offensive Operations	3-1
Fundamentals	3-1
The Deliberate Attack	3-2
Penetration	3-13
Movement to Contact	3-16

	<i>Page</i>
Exploitation and Pursuit	3-31
Follow and Support	3-36
Transition to the Offense	3-43
Chapter 4. Infantry Division Defense	4-1
Types of Defense	4-1
Fundamentals	4-1
Defense In Sector: Terrain Retention	4-2
Defense in Sector: Defend in Depth to Defeat Enemy Force	4-13
Mobile Defense	4-32
Transition to the Defense	4-36
Chapter 5. Concurrent Operations	5-1
Rear Operations	5-1
Deep Operations	5-15
Reconnaissance Operations	5-20
Security Operations	5-23
Targeting	5-30
Suppression of Enemy Air Defense Operations	5-37
Army Airspace Command and Control	5-42
Electronic Warfare	5-54
Deception Operations	5-58
Counterfire	5-62
Chapter 6. Operations Other Than War	6-1
Fundamentals	6-1
Peacetime Activities	6-2
Postconflict Operations	6-14
Conflict	6-15
Noncombatant Evacuation Operations	6-24
Peacekeeping Operations	6-28
Peace Enforcement Operations	6-29
Chapter 7. Other Operations	7-1
Section I. Relief in Place	7-1
Section II. Retrograde Operations	7-5
Section III. Forward Passage of Lines	7-10

	<i>Page</i>
Section IV. Link-up Operations	7-13
Section V. Breakout From Encirclement	7-18
Section VI. Infiltration	7-23
Section VII. Air Assault Operations	7-28
Section VIII. Airborne Operations	7-34
Section IX. Movement Operations	7-54
Section X. Armored-Light Operations	7-62
Section XI. Two-Brigade Division Operations	7-80
 Chapter 8. Environmental Considerations	 8-1
Military Operations on Urban Terrain	8-1
Amphibious Operations	8-10
Winter and Cold Weather Operations	8-20
Desert Operations	8-24
Jungle Operations	8-27
River Crossing Operations	8-29
 Chapter 9. Future Technology, Sharpening the Warrior's Edge	 9-1
Command and Control	9-1
Sensing	9-2
Lethality	9-2
Fire Support	9-2
Survivability	9-3
Human Performance and Endurance	9-3
 Appendix. Example Tactical Standing Operating Procedure (TSOP)	 Appendix-1
Section I. General	Appendix-1
Section II. Command and Control Procedures	Appendix-2
Section III. Standing Operating Procedures	Appendix-6
Section IV. Reports	Appendix-70
 Glossary	 Glossary-1
 References	 References-1
 Index	 Index-1

INFANTRY DIVISION OPERATIONS
Tactics, Techniques, and Procedures

PREFACE

Field manual (FM) 71-100-2 is a “how to” guide for the employment of US light, airborne, and air assault infantry divisions in combat. It describes tactics and techniques for the conduct of combat operations and the integration and coordination of combat, combat support (CS), and combat service support (CSS) functions. It supports the doctrinal concepts and principles of FM 71-100. The tactics and techniques in this manual are illustrative in nature and a guide only. Readers should not assume these methods are the only way of conducting operations. FM 71-100-2 must be used in conjunction with FM 101-5.

This manual has been written for the division commander and his staff, major subordinate units of the division and corps, and students at service and staff colleges. Other service and allied commanders and staffs may also find FM 71-100-2 useful in understanding how the infantry division plans and executes operations. FM 71-100-2 is compatible with current joint and combined doctrine. The authors assume the user has read FMs 100-5, 100-2-1, 100-15, 71-100, 101-5, and 101-5-1.

Unless otherwise stated, masculine pronouns apply to both men and women.

The term armored units refers to both armored and mechanized forces.

The proponent for this publication is the Combined Arms Command, TRADOC. Send comments and recommendations on DA Form 2028 directly to Commander, US Army Combined Arms Command, ATTN: ATZL-SWW-D, Fort Leavenworth, Kansas 66027-6900.

INTRODUCTION

Since the publication of the 1986 version of FM 100-5, the world and our Army have undergone significant changes. Our country has been involved in three key victories—Panama, the Gulf War, and the Cold War. Concurrently, the Army has undergone a force structure change, reducing the size of the Army and the number of forward deployed units geared to counter a Warsaw Pact invasion. These external and internal changes have caused us to modify how we as an Army think and conduct warfare. The 1993 version of FM 100-5 reflects these changes.

Military doctrine presents fundamental principles that guide the employment of forces. Doctrine is authoritative, but not directive; descriptive, not prescriptive. It provides the distilled insights and wisdom gained from the Army's collective experience with warfare. However, doctrine cannot replace clear thinking or alter a commander's obligation to determine the proper course of action under the circumstances prevailing at the time of decision.

The five Army operations tenets are the basis for the development of all current US Army doctrine, tactics, and techniques. Success on the battlefield will depend on our ability to fight according to these tenets: initiative, agility, depth, synchronization, and versatility.

Initiative sets or changes the terms of battle by action. It is the effort to force the enemy to conform to our operational tempo and purpose while retaining our freedom of action. This will require commanders to understand the intent of their commanders two levels above—centralized planning but decentralized execution.

Agility is the ability to act faster than the enemy—a prerequisite for seizing and holding the initiative. Quickness permits the rapid concentration of combat power against the enemy's vulnerabilities. It requires the commander to constantly read the battlefield, anticipate, make quick decisions, and act without hesitation. This may require committing forces quickly without complete information when situations are time-sensitive. Agility is both mental and physical flexibility—seeing and reacting rapidly to changing situations.

Depth is the extension of operations in time, space, resources, and purpose. The commander uses these factors in thinking in depth to forecast, anticipate likely events, and expand his freedom of action. He then applies them to arrange all available resources to attack the enemy simultaneously and sequentially throughout the depth of the battlefield.

Synchronization is the focus of resources and activities in time and space to mass at the decisive point. Although the activities such as intelligence, logistics, and fires and maneuver may occur at different times and places, they are synchronized when their combined consequences are felt at the decisive time and place. The product of effect synchronization is the maximum use of every resource where it will make the greatest contribution to success.

Versatility is the ability to shift focus, to tailor forces, and to move from one mission to another rapidly and efficiently. It implies a capacity to be multifunctional, to operate across regions throughout the full range of military operations, and to perform at the tactical, operational, and strategic level.

Again, doctrine presents principles that guide the employment of forces. Tactics, techniques, and procedures found in FM 71-100-2 support US Army doctrine. As professional soldiers, we must take these principles and apply them to our given missions and operations.

CHAPTER 1

LIGHT, AIR ASSAULT, AND AIRBORNE INFANTRY DIVISIONS

The mission of light, air assault, and airborne infantry divisions is to close with and destroy the enemy as well as to control land areas, including population and resources. These divisions make optimum use of offensive, decentralized, irregular-type operations by highly trained small units. Infantry divisions are austere and capable of conducting independent operations for only 48 hours. They are experts in urban warfare, jungle warfare, and infiltration operations and can kill enemy armored vehicles on any battlefield.

LIGHT INFANTRY DIVISION

The organization of the light infantry division (Figure 1-1) provides it the flexibility to accomplish global missions on different types of terrain and against a variety of enemy forces. It differs from other infantry divisions in both design and concept of employment.

The light infantry division is the most rapidly and strategically deployable of the various types of US divisions. It is organized to fight as part of a larger force or a joint task force in conventional conflicts, or independently in operations other than war. The ability of its command and control structure to readily accept augmentation forces permits task organizing for almost any situation, in almost any environment. The factors of METT-T (mission, enemy, terrain, troops and time available) largely determine the augmentations required for the division. (Common augmentation includes helicopters, artillery, military police, truck units, engineers, psychological operations (PSYOP), and civil affairs.

Although employed as an entity, the division disperses widely throughout a large area and conducts synchronized, but decentralized, operations, primarily at night or during periods of limited visibility. It achieves mass through the combined effects of synchronized, small-unit operations and fires rather than through the physical concentration of forces on the battlefield. Massing of light division forces occurs only when the risk is low and the payoff is high.

At the tactical level, the best use of the light force is as a division under corps control. The corps commander must ensure that the mission assigned to the light force capitalizes on its capabilities. The division conducts operations exploiting the advantages of restricted terrain and limited visibility.

AIR ASSAULT DIVISION

The air assault division (Figure 1-2) combines strategic mobility with an extremely high degree of tactical mobility within its area of operations (AO). The air assault division conducts combat operations with infantry, aviation, and the necessary CS and CSS to strike overextended distances and terrain obstacles to attack the enemy—deep, fast, and often.

Airmobile divisions provided the US Army the operational foundation for air assault division operations. However, the air assault division conducts more than airmobile operations. It is important to recognize the distinction between airmobility and air assault. Airmobility is the use of Army aircraft whenever and however they improve our ability to fight. Essentially, movement of troops and equipment from one secure area to another is conducted with the helicopters which depart the AO after insertion. Conversely, air assault operations involve combat, CS, and CSS elements (aircraft and troops) deliberately task-organized for tactical operations. Aviation assets are completely integrated with ground forces. Additionally, air assault operations generally involve insertions and extractions under hostile conditions, as opposed to mere air movement of troops to and from secure locations about the battlefield.

Once deployed on the ground, air assault infantry battalions normally fight like those of the infantry division; however, normal task organization of organic aviation increases firepower and permits rapid aerial redeployment. The essence of modern-day air assault tactics is rapid tempo of operations over extended ranges by air assault task forces. Execution of successive air assault operations enables the division commander to seize and maintain the initiative.

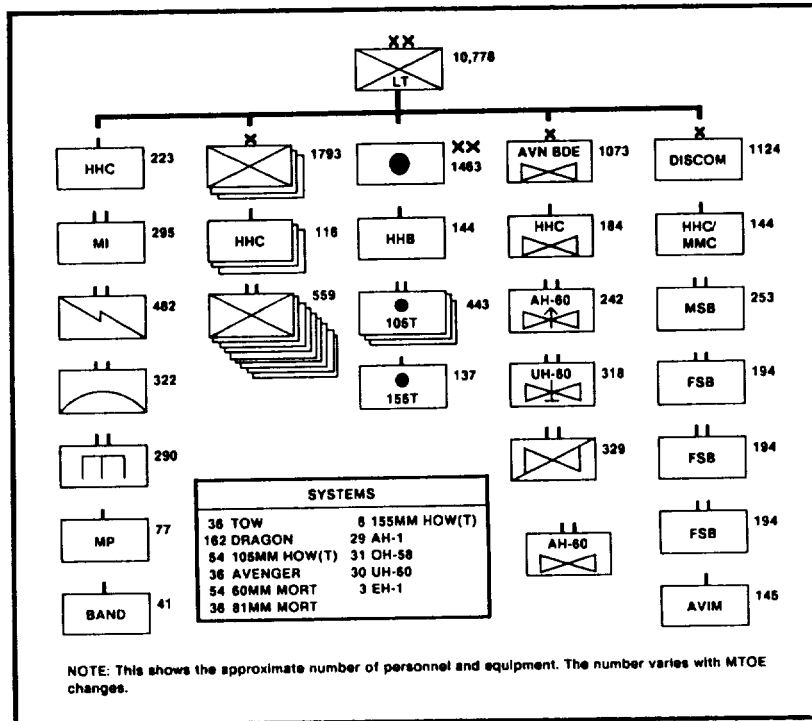

Figure 1-1. Light infantry division

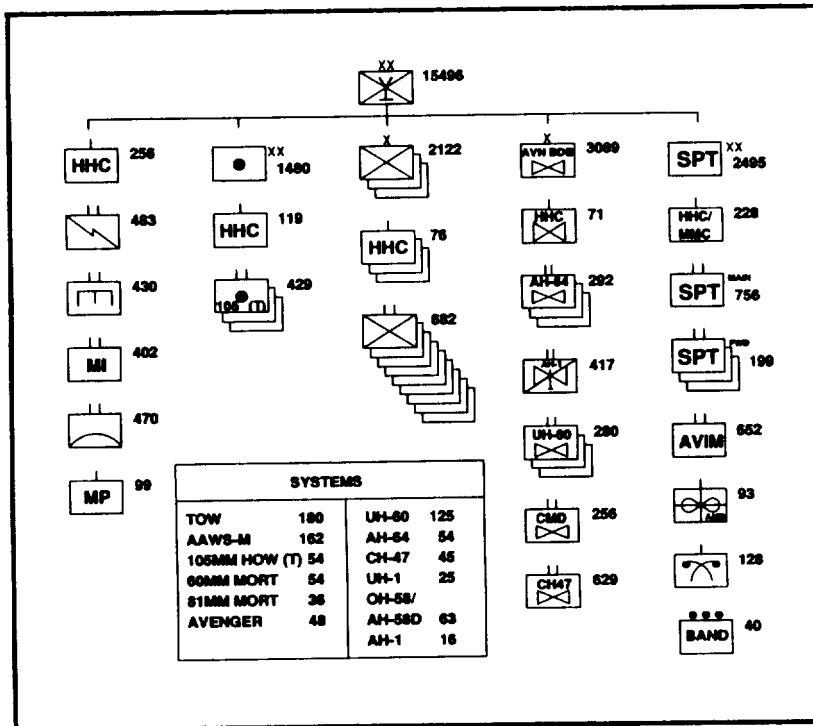

Figure 1-2. Air assault division

For deployment purposes, the Army considers the air assault division a “heavy” division. Planning normally envisions rapid deployment by strategic airlift of a tailored brigade package, followed by the remainder of the division by sea. Deploying the full air assault division by sea requires slightly less sealift than deploying an armored division.

The air assault division is best employed as a complete division in high-tempo, offensive operations, capitalizing on vertical envelopments and vertical turning movements. It is ideally suited to conduct either a major portion or all of a corps’ deep operations, particularly in exploitation and pursuit. In the defense, the division is well-suited to conduct economy of force operations over vast frontages, reserve operations, or covering force operations and other corps security missions.

The air assault division operating at full tempo consumes 400,000 gallons of JP8 fuel daily, essentially making it an armored division for logistics support. The corps makes special provisions to sustain the air assault division, particularly in deep operations. Often, joint assets

such as intratheater airlift are required to sustain the division.

AIRBORNE DIVISION

The airborne division (Figure 1-3) is organized to deploy rapidly anywhere in the world—

- To conduct combined arms combat parachute assault to seize and secure vital objectives.
- To rescue US nationals besieged overseas.
- To reinforce forward-deployed forces.
- To serve as a strategic or theater reserve.
- To conduct large-scale tactical raids.
- To occupy areas or reinforce friendly or allied units beyond the immediate reach of ground forces.
- To capture one or more intermediate staging bases or forward operating bases for ground and air operations.

The airborne division conducts airborne assaults in the enemy’s rear to secure terrain or to

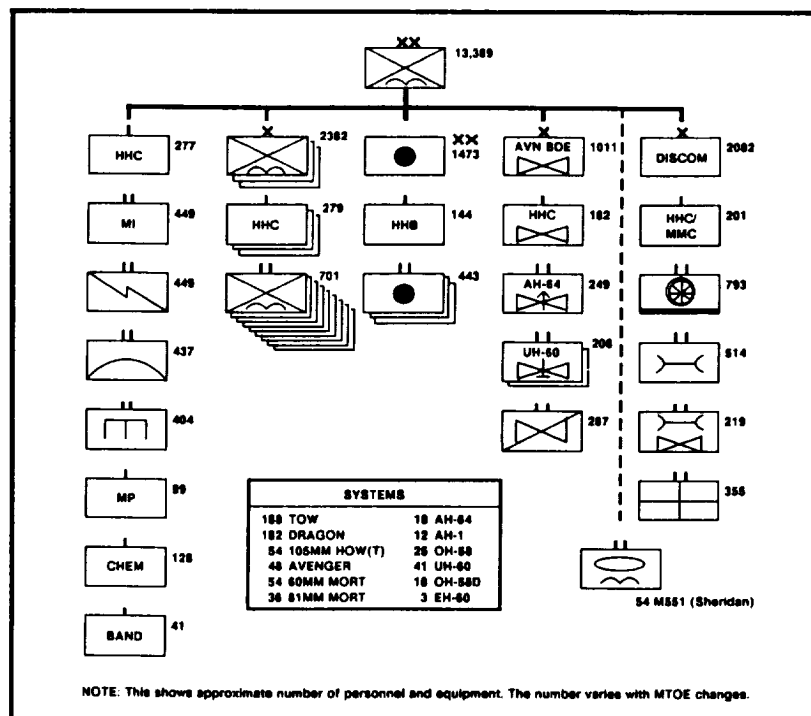

Figure 1.3. Airborne division

interdict routes of resupply or enemy withdrawal. It is ideally suited to seize, secure, and repair airfields to provide a forward operating base for follow-on air-landed forces. It can conduct missions normally assigned to infantry divisions.

The airborne division achieves surprise by its timely arrival on or near the battlefield. The aircraft range and instrumentation capability allow the Air Force to accurately deliver the airborne

division into virtually any objective area under almost any weather condition.

Because the airborne division is tailored for airdrop operations, it can be employed rapidly. All equipment is air transportable and, except for aircraft, must be air-droppable. All personnel are trained for airborne operations. Once deployed on the ground, airborne infantry battalions fight like those of other infantry divisions.

COMMAND AND CONTROL

In modern battle, the sheer magnitude of available information challenges leaders at all levels. Ultimately, they must assimilate thousands of bits of information to visualize the battlefield as it actually is and then to direct the military efforts they head to make them what they must be to achieve victory. Thinking and acting are simultaneous activities for commanders in battle. The commander leads, conceptualizes, synchronizes, and makes timely key decisions; the staff acquires, synchronizes, and disseminates decisions and information.

Section I. COMMAND AND CONTROL FUNDAMENTALS

Command and control(C²) is not a single term as commonly perceived and used. Command and control are separate and distinct, with differing applications to how the division fights.

Command is the art of assigning missions, prioritizing resources, guiding and directing subordinates, and focusing the entire division's energy to accomplish clear objectives.

Control is defining limits, computing requirements, allocating resources, prescribing requirements for reports, monitoring performance, identifying and correcting deviations from guidance, and directing subordinate actions to accomplish the commander's intent.

Control serves its purpose if it allows the commander freedom to operate, delegate authority, lead from any critical point on the battlefield, and synchronize actions across his entire AO. Moreover, the command and control system must support the ability of the commander and his staff to adjust plans for future operations even while focusing on the current fight. The related tools for implementing command decisions include communications, computers, and intelligence.

The size of a command post's structure depends on the amount of control demanded by the commander and higher headquarters. The more control imposed, the less command applied.

COMMAND AND CONTROL GUIDELINES

Basic, time-tested imperatives drive the successful development and efficient operations of the division's command posts (CPs) and determine their effectiveness in combat:

- A headquarters must be small to be efficient.

- Just as there can be only one commander, there can be only one command post exercising control at any one time,

- If a commander is to be effective in a crisis, he must limit the number of voices he hears.

- If a commander wants his staff to keep him informed, he should avoid lengthy prepared briefings and rely on unstructured, unscheduled discussions. This does not mean that briefings in CPs do not occur. They occur periodically to keep all up to date and to obtain needed information.

- When a commander gives a subordinate a new or revised mission, he should deliver or explain it orally and, preferably, face to face.

- Organizing a CP is a science whose purpose is to acquire and disseminate information in a prioritized fashion.

The commander should not stay in the command post. The best way for him to get information is by firsthand observation, from his own CPs, by visiting subordinate CPs, and by listening to subordinate command nets, including brigade, battalion, and company nets when necessary.

COMMAND POST RELATIONSHIPS

The division's command posts are generation centers for information, acquisition, processing, dissemination, and orders. They exist to support the commander wherever he may be on the battlefield. Within current force structures, the division command and control system can be effectively organized and implemented. However, the commander and staff must clearly understand the relationship between the command and control

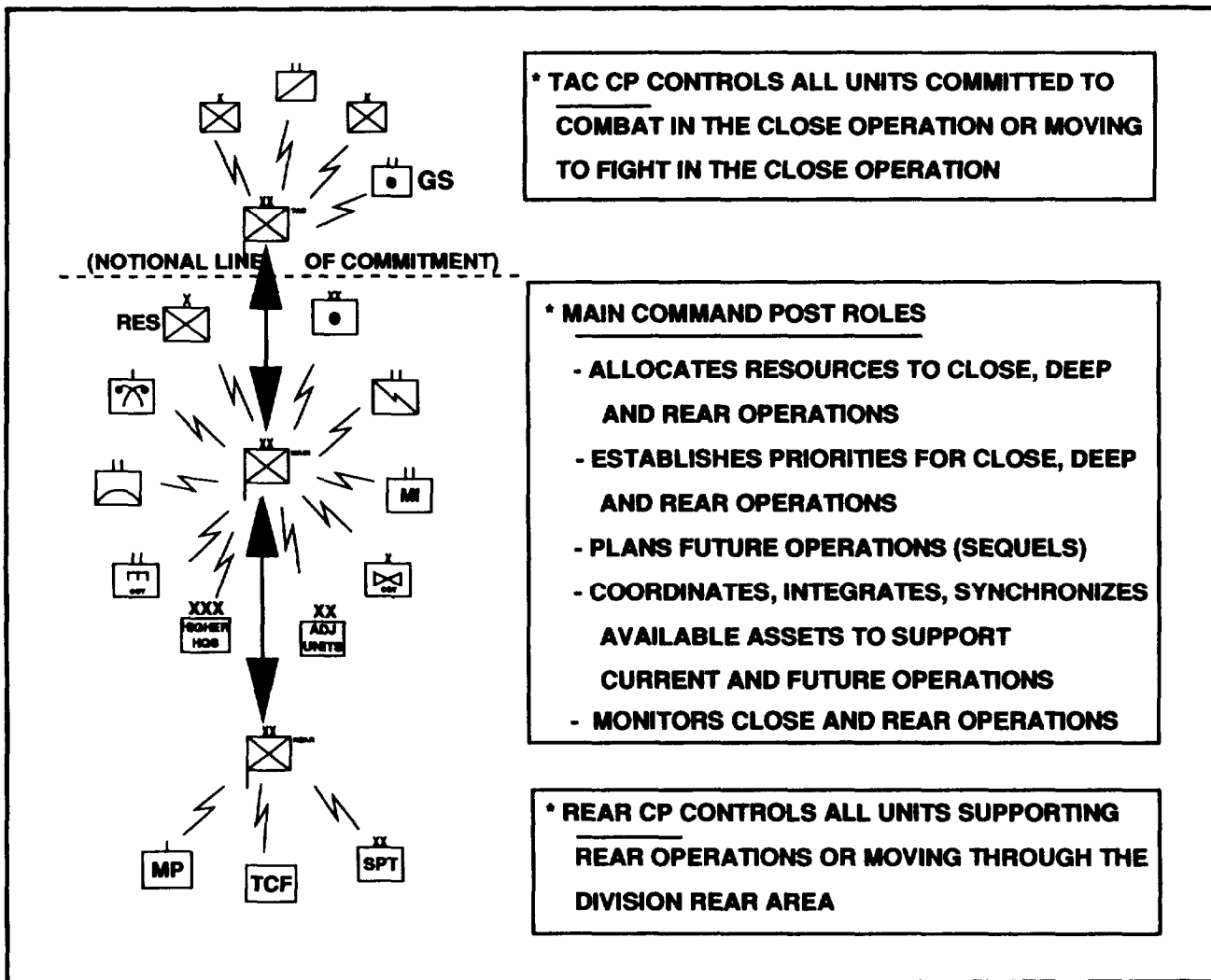

Figure 2-1. Division CP employment: roles and relationships

facilities supporting the division and the doctrinal functions performed by each as part of the total effort.

Doctrinally, the division fights *one battle* with three different, and normally distinct, operations—deep, close, and rear. If the division fights only one battle, then the principle of unity of command and common sense mandate that it have only one central command post (Figure 2-1). In the division, unity of command is manifested in the main CP. *The division resources TAC and rear CPs as extensions of the main CP, focusing on specific areas of operation.* The TAC CP is concerned primarily with the close operation; the rear CP, with rear operations. Each command

post performs its roles and functions within the overall mission of the division, as orchestrated by the main CP.

With three CPs simultaneously participating in the battle, confusion can often result. Who is really in charge? A clear delineation of authority and responsibility of the three CPs must be made in unit SOPs.

Division command post staff activities have five common functions:

- To provide information,
- To make estimates.
- To make recommendations for decisions.

- To prepare plans and orders.
- To supervise and monitor the execution of decisions.

Only the division main CP has the capability to plan sequels to the current mission.

TAC CP

The TAC CP must be well forward to respond to the immediate tactical requirements of the close operation. It should be minimally structured and manned to support maneuver, intelligence, mobility, and fire support. Its main focus is the control of close operations; it should not be distracted from that focus. The TAC controls only units committed to or engaged in close combat with the enemy. Main or rear CPs perform all other command and control functions. The main or rear CPs also control units within the division AO which are not committed to the close operations.

Main CP

The division main CP performs seven primary functions to support the division battle as well as the collateral support functions for the tactical and rear command posts. These are—

- Planning.

- Coordination.
- Integration.
- Synchronization.
- Prioritization.
- Allocation of resources.
- Monitoring of close and rear operations.

If units or elements are assigned to or support the division, then a staff element at the main CP must focus on those elements and integrate their current and future support to the close, deep, or rear operations. Immediate tactical decisions are rarely made at the main CP because it does not have the most current information. However, the main CP does make decisions based on requests from the TAC and rear CPs that support immediate close and rear operations.

Rear CP

The division rear CP performs the functions of sustainment, terrain management, movement control, security, and fire support. The rear area is no less an assigned AO than is a brigade AO. As in brigade areas, there will be numerous fire support requirements in the rear for rear tactical operations, tactical air support, artillery, and electronic warfare.

Section II. COMMAND POST OPERATIONS AND TECHNIQUES

ALTERNATE COMMAND POST

An alternate CP must be designated with a clear understanding of its purpose and roles. It does not have to be able to perform all main CP command and control functions. If a catastrophic loss occurs, an alternate CP enables the division to sustain continuous C² operations until surviving elements can rally at another location, assess casualties and damage, reorganize, and re-establish critical division C² functions. The alternate CP should be equipped with communications facilities capable of performing designated critical functions of the destroyed CP. The alternate CP normally does not support CP displacements.

An alternate division CP must retain the capability to command and control operations for its own units. There is no CP within the division with sufficient personnel or facilities to support its primary C² functions and also those of one of

the division command posts. If this is attempted, the functions of the division CP will quickly consume the austere C² facilities and assets of the alternate CP and degrade operational effectiveness.

A designated alternate CP is activated when the survivors of an attacked CP inform the command net of its attack, destruction, or inability to function; when no element within the command post can be contacted within a specified period of time; or when a unit or element reports that the CP has been destroyed and it is verified. Alternate CPs should be designated for the tactical, main, and rear CPs and criteria established for their activation in the unit tactical standing operating procedures (TSOPs).

The alternate CP for the TAC CP should be able to perform critical functions of the TAC CP G3, G2, and fire support element (FSE), in that priority. Normally, the first choice for a TAC CP alternate is the command group vehicles. This

element knows the situation and should be able to pick up the close operation without losing momentum and information transfer. It also possesses the organic communications capability and personnel to perform critical G3, G2, and FSE functions. Surviving personnel and vehicles, if any, rally at the command group and continue operations until a new TAC CP is organized. Once the new TAC is functional, information and operations transition from the command group to the TAC CP. If the command group is unavailable, then the next alternative for an adequate alternate TAC CP may be the division cavalry squadron CP. It possesses the staff, facilities, and communications to perform designated TAC CP functions.

The designation of an alternate CP for the main CP is more difficult because of the size and complexity of functions it performs. The problem becomes less complex when viewed as what critical functions can be performed at the alternate CP and what functions can be assumed by other CPs within the division. No other organic division CP is capable of assuming the functions of the main CP. External CPs that routinely send elements to the main CP assume responsibility for those functions if the main CP is destroyed.

When selecting a unit command post as the alternate for the main CP, the division must determine the effect the choice will have on current division tactical operations. For example, the division aviation brigade headquarters may be a better candidate for an alternate division main CP than the more often used DIVARTY CP. The DIVARTY TOC is neither manned nor equipped to support both division main and DIVARTY functions without serious degradation to current fire support operations. The aviation brigade has the organic communications to support only the command center, G3 operations, A²C², and planning functions. The number of surviving personnel and equipment from the main CP will determine the number of personnel and amount of organic equipment required of the aviation brigade CP. Other main CP functions must be temporarily assumed and performed by the engineer, signal, ADA, and MI battalions and DIVARTY until the main CP is regenerated. Despite a distance issue, some divisions use the

division rear CP as the initial alternate CP. A conceptual allocation of C² tasks and functions for alternate command posts follows.

<i>Main CP Function</i>	<i>Designated Alternate</i>
— Command Center	Aviation Brigade
— G3 Ops/Planning/ A ² C ²	Aviation Brigade
— G2 Ops/ASPS	MI Battalion
— FSE	DIVARTY
— Engineer	Engineer Battalion Staff
— ADA	ADA Battalion Staff
— NBC Element	Division Chemical Company
— ADSO	Signal Battalion

Divisions designate an alternate rear CP. Functionally, the division support command (DISCOM) CP is manned and equipped to assume critical functions of the G1, G4, and division transportation officer (DTO) from the rear CP CSS cell without impacting on the sustainment function. Should the DISCOM CP also be destroyed, the main support battalion (MSB) may be the next best alternative. The main CP G3operations cell can assume the rear functions of terrain management, security, and movement coordination. Selecting an alternate rear CP must not interfere with the capability of CSS elements to continue to sustain current operations logistically.

Designation of an alternate CP and subsequent transfer of functions to that CP require definitive, practiced staff drills to make the operation efficient and effective. Critical functions performed by each alternate CP must be prioritized as the transfer is made from one command post to another. Synchronization and coordination required from dispersed locations must be identified and exercised. The most critical consideration is to minimize disruption of the division's capability to command and control current tactical operations.

COMMAND POST PERSONNEL

Key to any command post operation is the type and quality of personnel that man it. Regardless of the equipment or facilities, the quality of

personnel remains the constant factor that defines effective CP operations. The division's command posts must be staffed with appropriate skills and military occupational specialities (MOSs) to perform the functions of the cell to which they are assigned. Personnel in the CP structure are organic to the division headquarters and headquarters company as well as to other organic and nonorganic elements that support the division. The assigned roles of officers and non-commissioned officers (NCOs) within the C² structure are critical to the effective functioning of the command post and to mission accomplishment. Each individual must not only be capable of performing his job but also understand how his job relates to others throughout the command post and the C² system. With the increasing complexity of command posts and equipment that supports them, a soldier must know more than his job's physical processes. He must also know and understand the intangible effects of his job within the command post.

The officer's role within the CP is primarily one of "seeing the battlefield." Officers must be capable of assessing the tactical situation, anticipating the enemy's intent, and determining the long- and short-term impact of friendly actions. Officers issue instructions in accordance with the commander's or decision maker's guidance. They develop estimates and plans via the decision-making process. Officers should maintain a wide view of the division operation. They should not routinely post the operations map, work MCS equipment, or answer telephones. Instead, they should stand back and assess the impact of messages received and tactical situations portrayed on the operations map. Officers that work in the command post must be trained in their functions, roles, and duties in support of the CP mission.

The noncommissioned officers assigned to the command post should be an integral part of all CP operations. Their role includes active participation in the planning and decision-making process. There are four functional area NCOs within the command post—operations, intelligence, combat support, and combat service support. All assigned or supporting NCOs within the CP support one of these four functional areas. If officers are not assigned or available, NCOs perform officer roles described above.

Normally, NCOs routinely focus on specific aspects of their duties or work area. Some specific responsibilities of the command post NCO are—

- Collecting, processing, and disseminating information within the NCO's cell, throughout the CP, and external to the CP.
- Preparing and updating staff estimates and preparing, reviewing, and issuing orders and plans. Formal training courses now available provide the capability to perform this function.
- Coordinating, synchronizing, and integrating internal CP and separate cell activities, such as maintenance of map boards, status charts, shift changeover procedures, and health and welfare of soldiers.
- Participating in command post site selection, reconnaissance, and movement.

Through training and practical experience, the NCO should be able to assume the duties of an officer in the event of the officer's temporary or extended absence from the command post. Command post NCOs are required to develop and train young soldiers and new NCOs in the individual and collective tasks associated with CP operations. If possible, personnel filling critical NCO positions should be graduates of, or scheduled to attend, the Battle Staff NCO Course.

The division command sergeant major (CSM) is the senior NCO in the division. His duties span a wide spectrum of NCO activities, including the CP. He must actively participate in the selection and retention of qualified NCOs for CP operations. He must rigorously enforce the use of available formal CP training courses by ensuring allocations are available and proper personnel attend. He participates in developing and implementing enlisted training and enlisted soldiers' tasks based on the unit mission essential task list (METL) and battle focus. The CSM monitors CP operations and NCO participation to ensure that all properly accomplish their specific duties. He must be able to advise and counsel NCOs actively and accurately about their command post responsibilities.

INFORMATION MANAGEMENT

The key to effective control in the division's command and control system is information

management. All information generated by automated and manual systems of the unit has one overriding purpose—to enable the commander to make timely decisions during the turmoil and confusion of battle.

There are three modes of information exchange between commanders and staffs and between command posts. These modes are called pipelines, alarms, and trees because of the difference in their demands on the command and control system.

The pipeline mode transmits information according to a set order and an established format. Routine reports such as the commander's situation report, logistics status report, and personnel status report move through the pipeline. Pipeline information contributes to the collection and analysis of information that is generally not time-sensitive in terms of decision making. It helps anticipate, identify, and solve problems. Automation greatly assists in the rapid dissemination and collation of information into and out of various sources.

Information displays must be both functional to maintain and meaningful to the commander or decision maker. Map size and displays should be consistent among division CPs. For infantry, map size may vary from operation to operation. Normally, map scales of 1:250,000 and 1:50,000 or 1:100,000 are used to display information.

The alarm mode signals the occurrence of one or more exceptional events. Commanders explicitly set alarms. Subordinates operating within the commander's intent set them implicitly. Alarms are difficult to automate in an electronic information system because all possible contingencies cannot be identified in advance. Alarms are those pieces of information that alert the commander that his plan is not going as he envisioned it and requires some corrective action. Alarms are generally time-sensitive and a priority action for the staff.

The tree is an inquiry-based, demand-pull means of searching for and acquiring information along the paths of a hypothetical decision tree. In this mode, information is a response to specific demands, which arise in turn from previously supplied information. Computer automation is

especially valuable in the rapid retrieval of information because of the complexity of even simple decision trees. The tree represents the numerous sources of information that exist in the division. It becomes the prime resource for retrieval of information or analysis of a critical decision.

Information generated by the unit is predicated upon and driven by the commander's critical information requirements (CCIR). The information system must focus on getting the right information to the commander or decision maker as quickly as possible. If a piece of information does not contribute to a current or anticipated decision, that information is "nice to have," but efforts to generate it should be abandoned. The commander, not a staff officer, develops CCIR. The staff may recommend CCIR to the commander as—

- Priority intelligence requirements (PIR) (how I see the enemy) to determine what the division wants or needs to know about the enemy.
- Friendly forces information requirements (FFIR) (how I see myself) to allow the commander to determine the combat capabilities of his units.
- Essential elements of friendly information (EEFI) to allow the commander to determine how he must protect from the enemy's information gathering sources.

The chief of staff or executive officer (XO) is the unit's information manager. He outlines and monitors the performance and responsibilities of the staff in processing information to support the operation and the flow that feeds the system. The CCIR are directly linked to present and future tactical situations and to previously identified decisions to make. The information manager collects, tasks, analyzes, and presents CCIR timely and accurately.

Specific requests for information and routine and standard reports (established by unit SOP) generate information within the division. *Routine reports are provided by exception when the information changes enough to require a decision or the need to take action.* To reduce the volume of data arriving at a headquarters for processing and dissemination, the using organization requests or pulls information to it. Information is not routinely pushed up to the higher headquarters.

Unless specifically requested, subordinate headquarters never send unanalyzed raw data to a higher headquarters (HQ). They send analyzed data in the form of information. The sender must analyze all information coming into a headquarters and pass the results of that analysis forward. Subordinate units rarely send higher headquarters the same information from multiple sources. When all raw data is forwarded, the volume of information cripples the higher staff because it must sort out the CCIR while also coordinating, integrating, and synchronizing current operations,

The CP displays information with charts and operations maps. Task organization or mission charts reduce need for discussion. Charts also use color codes to depict current status. Color codes rapidly present a clear status of items using color criteria established in the SOP. This allows the commander to quickly assess critical elements and focus the staff efforts to “fix” or “continue to fix” the problem. If he desires further information, the CP staff can retrieve or pull it from the submitting staff section or MSC in the tree mode. Only information that directly contributes to a commander’s critical decision is retrieved. This allows the staff time to continue routinely coordinating, integrating, and synchronizing current and future operations. The amount of time available and the experience of staff will be the driving factors.

A color code standard should be consistent throughout all echelons of the command. A separate color code for different elements or functions creates confusion. A commonly used standard color code is—

- GREEN—80 percent or greater combat capability remains—full strength.
- AMBER—60 to 79 percent combat capability remains—mission capable with only minor deficiencies.
- RED—40 to 59 percent combat capability remains—marginally mission capable with major deficiencies.
- BLACK—less than 40 percent combat capability remains—NOT mission capable.

Operations maps should contain only the minimum essential information to allow the commander to see the battlefield without unnecessary clutter. This is true for staff section maps, too. However, these maps must contain more detail to enable analysis of data before the staff provides information to the command center. On the other hand, the effort required to update an operations map with too much detailed information is time-consuming. It also interferes dramatically with coordination, integration, and synchronization. Commanders and staffs must discipline themselves to depict only what is critical at their level, and refrain from seeking data simply out of curiosity.

The operations NCOs of each element or section within each CP must manage information by maintaining a current operations journal. This is a chronological listing of messages, FRAGOs and warning orders received. It is a continuing requirement maintained to reconstruct events, clarify guidance, or validate requirements.

Maneuver Information

Maneuver is the responsibility of the operations officers (S3 or G3) at each echelon of command. Maneuver is the pivotal system around which all other support systems revolve. All information relating to the maneuver of forces or the coordination, synchronization, and integration of combat and CS elements passes through the S3 or G3 or supporting elements within the operations section.

Maneuver information must be distributed between the G3 operations elements at the TAC, main, and rear command posts. Command posts will receive different parts of the information, although all of it will eventually go to the G3 at the main CP for analysis and posting.

Maneuver information is normally reported on standardized tactical spot reports or the commander’s situation report, provided either manually or by computer. The critical element is the consistency of report formats. This aids in transferring data into information to higher headquarters. The division TAC CP receives maneuver information from committed brigade TAC CPS during or, as quickly as possible, after the situation has occurred in a “salute” format spot

report or the more detailed commander's situation report. The need for timely maneuver decisions and the commander's ability to see the close operation require expedited transfer of information to the division TAC CP by all committed brigade TAC CPs. The division TAC CP collates, posts, and analyzes this maneuver information, turning it into current or updated close operations information which it sends to both the division main CP operations cell and the corps TAC. Maneuver information maintained at the G3 operations of the TAC CP and the G3 operations of the main CP is identical in focus. Both focus on combat capability two levels down. The information that the main CPs G3 presents to the command center is an analysis of information on brigades and separate battalions. The G3 operations cell maintains supporting data to answer questions from the commander or chief of staff. This keeps information requirements current at an appropriate level for the echelon and command post requiring it. The TAC CP must have more current information than the main CP to make decisions on close operations. The main CP makes decisions affecting the division's future.

Intelligence Information

The G2 operations cell at the main command post collates all information relating to intelligence functions. The cell can monitor the entire intelligence battlefield by placing elements at the TAC CP to focus on close operations and at the rear CP to focus on rear operations. Through these extensions, the G2 can see the complete battlefield from the main CP and make decisions about future plans or in support of current ones.

To be effective, the intelligence flow must follow a clearly defined and disciplined path using established procedures and reports throughout each echelon from company to echelons above corps (EAC). All information received from subordinate and adjacent units other than quickfire targeting information *must* be analyzed (in haste or in detail) to convert it from raw data to intelligence appropriate for the echelon of command for which it is intended. For example, a committed brigade S2 sends the G2 at the TAC CP an intelligence summary or intelligence spot report containing analyzed information that confirms the

existence of a motorized rifle battalion at 75 percent strength facing the brigade.

The TAC CP G2 posts this information with other analyzed information received from the cavalry squadron and one other committed brigade. On the TAC CP G2's map, all this information becomes data which, after some analysis, confirms the existence of a motorized rifle regiment facing the division. The TAC G2 quickly passes this *analyzed* information to the G2 at the division main CP to include intelligence received from higher and adjacent units, the rear CP's G2 cell, noncommitted combat support units, and the MI battalion. This information then becomes data for further analysis by the commander in the command center.

Unless specifically requested, raw intelligence data should not be routinely passed to a higher or controlling headquarters. This will cause the bulk of data to increase greatly as it moves up each echelon, hampering staffs in effectively seeing the enemy and anticipating actions in a timely way. *Intelligence that can't be seen and used is not effective, regardless of the great efforts expended to produce it.*

PLANNING

The division plans element is located in the vicinity of the main CP and works for the G3. It is the only asset available to the division commander to allow him to maintain his ability to continually look towards the future and effectively transition from current to future operations. The plans element should not be diverted from its future planning process to participate in developing plans and orders to support branches to current operations. Warning orders or fragmentary orders (FRAGOs) required to support changes to the current operation (branches) are the responsibility of the G3 operations elements at the TAC, main, or rear CPs, not the plans element.

Corps and division are always planning. The division conducts planning in two types of environments—when it has a mission but is not committed to tactical operations against an enemy force, and when it is currently committed. Planning processes for both should follow the traditional, formal estimate process outlined in

FM 101-5. When conducting noncommitted force planning, the division may be located in a rear assembly area. Led by the plans cell, each CP element participates in and supports noncommitted force planning. Key to noncommitted planning is time available to conduct the formal, time-consuming, step-by-step, detailed staff estimate planning process. The result is a detailed, thought-out, and war-gamed plan used to begin the tactical operations of the division. Once the division is committed to a tactical operation, planning time is greatly reduced and becomes a precious commodity. Commander involvement becomes more critical.

Transition Operations Planning

The primary role of the plans element is to remain focused on the future operation by developing plans and coordinating, integrating, and synchronizing them with current operations to allow smooth transition from current to future operations. When committed against an enemy force, the division will not have a tactical pause to conduct the formal planning processes to prepare for the next operation. It must be trained to transition smoothly from one operation to another. This requires transition planning battle drills supported by all primary and supporting staff elements. Even when the division is not committed, the plans cell leads the planning effort. Each staff section supports the planning process and also monitors the current operations in preparing for combat activities such as reconnaissance, counterreconnaissance, movement, and resupply.

Several key factors are involved in the successful transition from one operation to another. They are—

- Early anticipation by the commander and the assignment of one clearly articulated future operations mission (or sequel).
- Development of a concept of operation that accepts risk with economy of force to allow mass.
- Continuous planning, coordination, integration, and synchronization of future operations requirements with those of current operations.

The plans element helps the division transition from one operation to another, the objective being to prevent a loss of tactical integrity and

momentum. In effect, the plans element performs the role of a second operations cell as it coordinates and synchronizes the future concept and plan within the context of current operations.

The main CP staff elements, less the plans element, control the current operation. They allocate resources and establish priorities in support of the current deep, close, and rear operations and monitor execution of the current plan. Each staff element in the main CP has a specific battlefield operating system (BOS) or function. In addition to monitoring current operations control requirements, staff elements work with the plans element to coordinate, integrate, and synchronize requirements for future operations. These current operations staff elements are the primary conduit for transmitting and coordinating information to their controlled elements for both current and future operations requirements.

Parallel Planning

Parallel planning is effective when dealing with reduced planning time and transitioning from one operation to another. Parallel planning is the act of conceptualizing, developing, and synchronizing a future operations plan (sequel) with a current operation and its continually changing situations. Parallel planning is used because the "one-third, two-thirds rule" and similar fractional divisions of time are often ineffective.

Parallel planning requires planners to be continually aware of current tactical developments. It emphasizes continuous information sharing through verbal and written means (warning orders, FRAGOs, and messages) to quickly distribute intelligence, planning guidance, and coordination instructions to subordinate, adjacent, and higher staff elements. Units need not wait for a detailed analysis or a single published order to begin their own parallel planning and orders development. Continuous information-sharing allows all units to receive information on the future mission early in the planning process. Thus commanders and staffs can manage their time to complete reconnaissance, troop leading procedures, and preparation for combat actions as early as possible, even when fighting a current operation. Under the one-third, two-thirds rule, lower-level units usually receive orders too late to

conduct reconnaissance, and to plan for logistics support and other basic requirements of combat.

The plans cell must have *one* mission only to develop and coordinate in detail while the division is committed. From development through approval of a course of action, that mission is the primary focus until its plan is fully coordinated, synchronized, and ready to execute.

Involving higher, lower, and adjacent staff elements early in the planning process allows the entire staff “to see” both current and future operation and help identify known or potential problem areas. Identifying conflicts early allows time to fix problem areas without disrupting the current mission. Elements of the main CP allocate resources and establish priorities for all units supporting the division’s current and future battle. Elements of the TAC, main, and rear s coordinate and employ units in support of the division current operation, understanding their roles in the future operation. If the plan needs adjusting, the plans cell modifies it, making the appropriate coordination. Once the plan is completed, coordinated, and distributed, the plans element keeps aware of the current operation. It focuses on the status, capability, and locations of units and their capability to implement the next plan. In this way, any posturing of units required by the plan can be adjusted and synchronized early enough to allow the future operation to begin from current positions. This minimizes disruptive movement and confusion on the battlefield.

REHEARSALS

A rehearsal is the art or process of practicing in preparation for a public performance. A division rehearsal for an impending combat operation ensures synchronization and agility through practice of the plan. A rehearsal reinforces the scheme of maneuver and the support of CS and CSS support units. It should identify problem areas and contingency actions, determine movement reaction times, enhance coordination, and refine the plan. A rehearsal should focus on actions critical to accomplishing the mission. This ensures the division can, in fact, accomplish the mission given its state of training, the orders issued, and the terrain and weather conditions

expected. Some type of a rehearsal should always be conducted.

Rehearsals are that part of the tactical operation in which the division, or elements of the division, conduct one or more exercises. They are executed according to a plan which approximates the specific operation. Rehearsals test the—

- Familiarity of all elements with the plan.
- Timing of detailed operations.
- Combat readiness of participating forces.

The division commander plays a crucial role. He is the driving force in the interaction which clarifies the plan in the minds of his subordinates. He must focus the staff to create conditions that replicate the upcoming operation. When conducting a rehearsal, the commander should emphasize key events that trigger friendly actions. The rehearsal is a tool the commander uses to reinforce understanding of the plan and to help subordinate commanders visualize the commander’s intent and what they can do when the battle does not go according to plan. In the final analysis, whether the commander, his chief of staff, or the G3 conducts the rehearsal, its effectiveness is the commander’s responsibility.

Planning Considerations

Responsibility for preparing rehearsal plans is the same as for preparing the actual operations plan. Rehearsal plans should be issued separately, but as close in time to the operations plan as practicable. In planning for rehearsals, consideration must be given to the number, nature, and scope of rehearsals; the date and time for each; and the area in which they will be conducted. Tactical forces must consider the difficulty of repair or replacement of equipment damaged or lost during rehearsals conducted after they leave the assembly area.

The number, nature, and scope of division rehearsals will be influenced by—

- The complexity of the tasks assigned to the elements of the division.
- The time available for rehearsals.
- The state of training of forces.

- The suitability of available rehearsal areas.
- Special or unusual problems to be faced in the actual operation, the solution to which must be accorded special attention in the rehearsal.
- Intelligence and counterintelligence considerations.

The dates of rehearsals and the time allocated for them must provide for—

- Complete and careful execution of the entire rehearsal.
- Repositioning of troops, equipment, and supplies which conforms to the original tactical plan,
- Rehabilitation or replacement of equipment and supplies, and repair or replacement of any damaged or lost vehicles or aircraft.
- Critiques at all levels of command to evaluate the rehearsal exercise, to emphasize lessons learned, and to correct mistakes.
- Time to fix problems,

Finally, selection of the rehearsal area is influenced by—

- Suitability of the area for maneuver.
- Similarity and location of the rehearsal area in relation to the actual AO.
- Feasibility of employing live fire in the rehearsal.
- Security.
- Susceptibility to enemy interference.
- Conditions which might adversely affect the health of the force.
- Activity of civilians which might interfere with the rehearsal.

Rehearsal Techniques

There are generally seven rehearsal techniques available to the division, each taking a different amount of time and producing differing results. Normally, time available dictates the technique used. A full rehearsal is normally conducted only when the division is not committed to tactical operations and is located in an area that can support a division-level rehearsal. The division cannot likely conduct a full rehearsal for

a future operation while simultaneously fighting a current operation. Whatever rehearsal technique is used, the enemy should be portrayed as being highly uncooperative.

Full Rehearsal

Full rehearsal is the most effective but consumes the most time and resources. This technique involves every soldier and system that will take a direct part in the operation. If possible, the full rehearsal should be conducted under the conditions (weather, time of day, and terrain) that are expected to be encountered during the actual operation. In defensive operations, a full rehearsal can be conducted over the actual terrain given adequate covering force and counter-reconnaissance security operations to protect the force. In an offensive operation, the full rehearsal can be conducted on any available terrain that closely matches the terrain and space parameters of the zone of attack. This type of rehearsal is the most difficult to accomplish because of the great demand on time and resources, but it provides the highest payoff.

Supporting forces within the division that do not participate directly in the tactical operation may not be required to participate in full rehearsals. Such forces may hold separate rehearsals or rehearse with other participants with whom they coordinate support.

Key Leader Rehearsal

Key leader rehearsal takes less time and resources than the full rehearsal because normally only division's key leaders are involved. It can be conducted day or night but should be under the conditions expected in combat. The commander decides the level of leader involvement, normally one of the orders groups from the SOP. These selected leaders rehearse the plan, in their assigned tactical vehicles, over the terrain. The terrain requirements are the same as for the full rehearsal; only the number of participants changes. This type of rehearsal is more appropriate for defensive operations.

Terrain Model Rehearsal

Terrain model rehearsal takes even less time and fewer resources than the previously described types. It can be conducted day or night under a

tent or in a building. If the terrain model is accurate, this technique is an excellent three-dimensional aid to assist subordinate leaders to visualize the battle. When possible, the terrain model should be constructed overlooking the actual terrain or, if the situation requires more security, within walking distance of a point that overlooks the terrain. This positioning is more appropriate for brigade- and battalion-level rehearsals but may apply to a division axis of advance or some other critical part of the division's AO.

The terrain model should depict all information shown on the operations overlay, to include names of key terrain features, enemy positions (known and suspected), and all critical fire control measures. A directional arrow placed on the terrain model can aid in orientation to the actual battlefield. All terrain features, phase lines, and objectives should be labeled with their appropriate names. The commander then assembles his key leaders and staff officers in front of the terrain model and the commander walks each subordinate leader through an interactive verbal execution of the operation. The execution of this rehearsal is conducted sequentially, either by phase, event, or time.

Sketch Map Rehearsal

The sketch map rehearsal can be conducted day or night, almost anywhere, with minimum time and resources. The procedures are the same as for the terrain model rehearsal, except that a sketch replaces the terrain model. Using sketches that are large enough for all participants to see, the commander takes his staff and each subordinate leader through an interactive verbal execution of the operation.

Map Rehearsal

The map rehearsal takes less time and resources than the sketch map rehearsal and can be conducted day or night. The commander uses a tactical map with an operations overlay as he walks his staff and key subordinate leaders through an interactive verbal execution of the operation.

Backbrief Rehearsal

The commander uses the backbrief technique to identify flaws or problems in the operation. It

reveals how subordinates intend to accomplish their mission. This technique allows the commander to clarify his intent early in his subordinates' tactical estimate procedure.

Radio Rehearsals

Radio rehearsals are conducted by staffs scheduled to participate in the tactical operation and usually take the form of command post exercises. Whenever possible, rehearsals should exercise all communication facilities and equipment.

Rehearsal Security

Because of the similarity between the rehearsal and the actual operation plan, strict security measures must be enforced during rehearsals. The reconnaissance for, selection of, and arrangements for the use of the areas in which rehearsals are to be held must be carefully conducted. Deception operations and measures may be necessary to ensure the security of the rehearsal. Operational security (OPSEC) measures can prevent unauthorized observation by personnel not part of the division, or unauthorized communication by CPs or personnel from supporting external units. Sealing off the rehearsal area with perimeter patrols or security screen is the most effective means of ensuring the physical security of the rehearsal area.

CONTINUOUS OPERATIONS

Combat operations are fast-paced, around-the-clock, and intense. These conditions challenge CP staffs as well as individual soldiers to keep going and units to accomplish their missions over extended periods of time. Soldiers must fight through 24-hour or longer periods. Stress and fatigue over time causes both individual and command post performance to deteriorate.

Continuous operations are a combat multiplier when effective performance is sustained. Performance degrades, however, when there is no opportunity for the unit to stand down or soldiers to catch more than a few minutes of sleep.

Every soldier (especially leaders), team, and unit must perform effectively in continuous combat. Being determined to endure does not ensure effectiveness. Leaders must identify, learn to cope with, and overcome adverse conditions in continuous operations.

Combat exhausts soldiers, reducing their ability to perform tasks as quickly or effectively as necessary, especially after 36 to 48 hours. Normal sleeping habits or routines are upset and soldiers feel the effects of fatigue and stress.

Soldiers accumulate a sleep debt when performing continuous operations under limited sleep conditions. The only corrective measure is sleep. Variables such as training, motivation, and interest can reduce the initial effects of sleep loss; however, no amount of training, motivation, or interest will maintain performance. Commanders must recognize the characteristics of sleep loss and understand—

- Six to eight hours of sleep per night maintains performance indefinitely.
- Four to five hours of sleep per night maintains effective performance for five to six days. A combination of 12 hours sleep and rest (about 8 to 10 of which is sleep) is required after 36 to 48 hours of acute sleep loss.
- Thinking ability degrades more rapidly than physical strength and endurance.
- Degradation of mental performance comes as early as 18 hours into sustained work.
- Speed and accuracy are trade-offs during sustained operations. Generally, it is better to maintain accuracy and sacrifice speed. The likelihood of errors, especially errors of omission, increases with sustained combat.
- The decline in performance when working continually without sleep is about 25 percent every 24 hours.

Commanders and staffs must consider the individual soldier's load when planning dismounted infantry operations. It impacts not only on the endurance of the soldier, but also on the performance of the mission. The soldier's load also impacts the limited transportation assets of the division, and the speed, distance, and duration of the division's operations.

FM 21-18 and FM 7-8 address soldier's loads and provide planning factors and techniques for managing soldier loads. They also provide time-distance planning factors. Commanders and staffs must consider these factors a part of METT-T

when planning division operations. This is particularly true for infiltrations.

Continuous operations are combat multipliers only if commanders can manage sleep and stress to sustain effective performance. Physical conditioning and training are important. Physical conditioning delays fatigue, builds confidence, and shortens recovery times after sleep deprivation, illness, and injury. Overlearning and cross training help soldiers who perform duties requiring a high degree of mental skill. Overlearning a skill provides greater reliability and more rapid performance. Cross training permits soldiers to share duties and to cross check computations. Training under conditions of continuous and sustained operations allows units—

- To develop sensible standing operating procedures (SOPs).
- To develop and execute plans that provide at least four hours of uninterrupted sleep each day.
- To learn additional time needed to execute tasks for each successive period of operations without sleep.
- To learn recovery sleep needed to restore normal performance following sustained operations without sleep.

Before the need arises, commanders should identify and support critical skills. A critical skill is one a soldier must be able to perform, regardless of fatigue, so that he or his comrades can survive. The means for support must be familiar, practiced, and comfortable. Supports may be schemes or procedures rather than physical objects. For example, a fire support officer's (FSO's) ability to quickly call for fire on an enemy position is a critical ability. Determining accurately a set of six-digit grid coordinates to the position may be difficult for a fatigued soldier. A support example is plotting targets, groups, and series on a map from which the FSE or FSO can quickly engage the enemy. When fatigued, the soldier can do this easier than determining precise locations.

As soldiers become increasingly worn out, leaders must—

- Give only simple directions. Fatigued soldiers have difficulty in understanding complicated directions and are likely to forget some of them.

- Give complete, clear, precise orders. Leaders must leave no room for interpretation. Degraded soldiers have great difficulty in reasoning. They cannot “fill in” anything that has not been said explicitly.
- Repeat orders and directions. Leaders must have degraded soldiers repeat orders given to them or even write them down. Soldiers’ memories for new information are faulty. They are likely to forget orders or parts of orders almost as soon as they are given.
- Double-check themselves and others. Orders given and acknowledged may not be carried out correctly or completely. Therefore, it is necessary to double-check constantly to see if orders have been executed as intended. Leaders should arrange a way to double-check their own activities.

Leaders, on whose decisions mission success and unit survival depend, must get the largest allocation of sleep. (This may seem contrary to military tradition, but it is sound practice.) Commanders must plan and schedule their own sleep. Sleep priority goes to soldiers whose jobs require them to perform calculations, make judgments, or evaluate information. If a single unbroken period of four to five hours is not available, naps should be taken. (This is less restorative however.) Priorities for sleep scheduling are—

- 2400-0600—best period.
- 1200- 1800—next best.
- 1800-2400—third best.
- 0600-1200—least desired.

Command and control of continuous combat operations requires the CP to operate effectively over long periods of time until the unit has accomplished its mission or is pulled off line. Command post personnel will not function efficiently under the stress of combat without established work cycles that allow rest periods. To provide this rest and accomplish the continuous operations requirement, division CPs establish designated work shifts for available personnel. Most of the disruption of the continuity of TOC operations occurs during the changeover from one shift to another. Command post work cycles are established to support two 12-hour shifts with personnel

availability as the primary factor influencing the length of a shift.

Scheduling *en masse* shift changeover of the entire CP at 12-hour intervals is not effective. It degrades efficiency of the tactical operation center (TOC) in operations and staff functions. It allows a mass departure of the last shift and a complete loss of the collective knowledge of the last 12 hours of the operation and planning coordination. Numerous incidents transpire during a 12-hour shift. Regardless of the thoroughness of the shift briefing, supporting decisions and rationale can be forgotten or deemed unimportant and not briefed in the haste to go off shift. Incoming shift personnel may then confront situations early in their shift about which they have no knowledge. This places them, as well as the entire division, at an information disadvantage, and they lose effectiveness in controlling the current operation and planning the future operation. The CP loses valuable time in researching answers and the synchronization of operations suffers equally.

Another disadvantage to the mass shift change is that different cells and elements within the TAC, main, and rear CPs have different time frames within which a shift change is more practical. This is normally a result of specified times that reports are due to higher headquarters or other requirements generated by the mission or tactical situation. If the command post shift changes are scheduled to coincide with the headquarters company feeding plan and the commander’s morning and evening update, then each element within each CP will not have the flexibility to establish a shift change schedule which appropriately supports its functions and time lines. Maintaining and updating knowledge and an information base is key in structuring and conducting shift changes.

The shift change should not affect TOC operations. A proven method of scheduling shifts and maintaining continuity of information is to stagger the shift change during the 12-hour shift window established in the unit SOP. The staggered shift can be conducted by the entire command post or by each cell and element independently, depending on requirements and peak load times.

The staggered shift change involves scheduling officers, NCOs, and enlisted men on overlapping shifts so that the new shift element has access to a body of knowledge four to six hours old. This technique eliminates the knowledge vacuum evident at the beginning of the shift when using the *en masse* method. Figure 2-2 provides an example of a shift wheel technique for use by each internal cell and element within each CP in planning and displaying shift schedules.

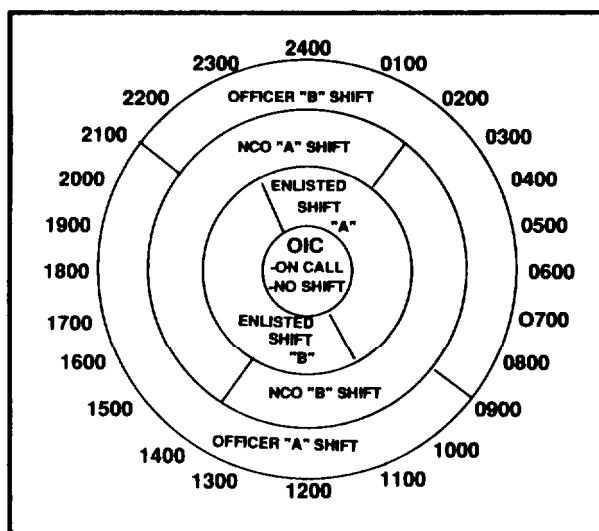

Figure 2.2. Shift wheel technique

By staggering personnel into the shift, the unit has a constant interface of new and old shift personnel working within the CP. For example, using the shift wheel, officers can change their shift at 0900 and 2100 hours with an informal map brief and exchange of significant events and guidance. The new officer is now on duty with an NCO who has been there for six hours and is aware of the rationale and circumstances leading to the current situation. The NCOs can change at 0200 and 1400 hours, and enlisted men at 1100 and 2300 with the same types of information overlap and exchange as they pertain to their duties.

When the CP displaces, it must do so without waking up and working off-shift personnel. Every effort should be made to ensure off-shift personnel receive all the rest the tactical situation will allow so that they are mentally alert when they come on shift. When rest for the off shift is not feasible, essential rest periods must be re-established as soon as possible.

LIAISON OPERATIONS

The division conducts liaison operations to aid in coordination, synchronization, and parallel planning. Liaison teams must have their own transportation and communications links to their headquarters. Liaison teams may require a foreign language capability when working with allies.

Reciprocal liaison involves exchange of liaison teams. Reciprocal liaison is required when a formation is placed directly under the command of a headquarters of a different service or nationality, or when units of different nations are adjacent.

The liaison officer (LO) represents the commander at the headquarters of another unit for effecting coordination and promoting cooperation between the units. The selection criteria for liaison officers should include knowledge of the unit's situation, ability to communicate effectively (language capability, as required), and other special criteria that will enhance effective liaison.

When liaison is not reciprocal, responsibility for establishing liaison is normally—

- From left to right.
- From rear to front units of the same echelon.
- From higher to lower echelon (for operational control (OPCON) or attached brigades).
- From supporting to supported unit.
- From moving force to in-place force.

Liaison from left to right facilitates flank coordination and flank security. LOs must focus on comparison of the two units' concept of operations and commander's intent. Of particular concern is the horizontal synchronization of the BOS across the unit boundary:

- Do intelligence systems complement each other?
- Are predictions and time lines synchronized?
- Do the array of maneuver forces and forms of maneuver complement each other or are there gaps or weaknesses created along the boundary?
- What fire support coordination measures are established, and where?

- Are there gaps in counterbattery or counter-mortar radar coverage?
- Do mobility and survivability plans complement each other or are unit obstacles easily bypassed through the adjacent division's sector?
- Does air defense coverage inadvertently create an air avenue approach into another division's zone?
- Are coordinating points and the degree of coordination (exchange of LOs, visual contact, or physical contact) the same in each division?
- Can emergency CSS support be coordinated?

During conduct of operations, the LO must keep abreast of the situation in each unit. He must advise his parent unit of developments in the unit he is with that may affect the parent unit. He must continue to monitor the horizontal synchronization of BOS. The LO is not a decision maker or a synchronizer, but he represents his commander and advises his parent unit of what is happening in the adjacent unit.

Liaison from rear to front is similar to liaison from left to right. The LO to the forward unit examines and reports on the forward unit's concept and intent and provides combat information and intelligence to his unit. He provides mobility and survivability information which may impact on his unit.

The LO's key role is to provide information which allows his unit to parallel plan in real time. He may recommend positions for his unit to occupy as it moves forward. He may coordinate terrain management. The bottom line is that he assist in maintaining the agility of his unit.

Liaison from higher to lower does not normally occur with brigades assigned to the division. This liaison normally occurs when a brigade is attached or is placed OPCON to the division. Additionally, divisions often send their LO to corps. The primary role of this LO is to maintain continuity of information and operations.

The LO primarily ensures the subordinate unit understands how the division operates. Many of the functions an LO conducts left to right or rear to front are fulfilled through normal command and staff relationships.

At division level, *liaison from supporting to supported unit* occurs when a division is given a follow-and-support mission. The LO conducts his activities much the same as a rear-to-forward unit liaison. The information he provides helps his unit to support the forward unit.

A two-person liaison team does not normally conduct *liaison from a moving force to a force in place*. The moving force normally collocates command posts to enhance the primary and special staff officer coordination.

Duties and Responsibilities

The liaison team's parent unit headquarters should provide the following:

- Transportation.
- Radio.
- Signal operating instructions (SOI) (LO copy).
- SOI extract for gaining unit.
- KYK 13 with current and future crypto net variable (CNV) fills (if necessary).
- Maps (covering sector, gaining unit sector, and route between).
- Overlay paper or acetate and equipment to make overlays.
- The current operations order (OPORD) and FRAGOs.
- The most recent commander's situation report.

The following items represent the minimum initial information about the parent unit the LO should provide the host unit:

- Current mission.
- Future operations.
- Task organization with changes.
- Boundaries with changes and the time effective.
- Fire support and engineer overlays and plans.
- Current logistics situation.
- Personnel situation and critical MOS shortages.
- An intelligence situation update.
- Current systems status.

The liaison team should be added to the TOC access roster of the host unit and able to identify security clearance (coordination with assistant chief of staff (ACofS), G2).

On arrival at the host unit, the liaison officer—

- Establishes communications with his unit and receives updated information.
- Reports to the commander or his representative (chief of staff (CofS), G3, operations duty officer) and should be prepared to brief his unit's situation.
- Visits each staff section, provides information as required, and obtains information he must transmit to his unit.
- Ensures his location at the headquarters is known at all times (for example, the G3 operations cell or command center).
- Acquires as much information as available about the host unit's mission, unit locations, future operations, and commander's intent. Accuracy is critical.

During his liaison tour, the LO should accomplish his mission without interfering with host unit operations. He must stay informed of his own unit's situation and provide that information to the commander and staff of the host unit. He must keep an appropriate record of reports.

He informs the host unit commander of the content of reports sent to the LO's parent headquarters. He reports promptly to his parent headquarters if he is unable to accomplish the mission.

On returning to his parent headquarters, the LO will—

- Clearly and accurately brief the commander of his representative (TOC duty officer, G3 or S3, CofS or XO) concerning the mission of the visited headquarters, unit locations, future operations, and the commander's intent.
- Transmit mission requirements and requests for information from the visited headquarters.
- Brief representatives from all staff sections on information received during the liaison visit.
- Keep abreast of the situation and be prepared to perform his next liaison mission.

LO Techniques

Many first lieutenants and junior captains are assigned as liaison officers on brigade and division staffs. These are table of organization and equipment (TOE) positions. Unfortunately, these officers are given few opportunities to act as LOs and they know little about the job. The following are helpful LO hints:

- An LO “gets as good as he gives.” The LO must anticipate the types of information the visited unit will want and types of questions it will ask.
 - Ž LOS should have with them a list of division, major subordinate command (MSC), and separate unit commanders and staff officers. Knowing names makes it easier to communicate when the LO's unit and the visited headquarters start talking to each other.
- LOs need to take their security clearances as well as other “qualification” papers. LOs should be ready for a long stint at a TOC and prepared to sustain themselves.

As soon as an LO arrives at his destination, he should call and check in. While *en route*, he may be out of touch with his unit for some time, and many things can change.

- An LO should meet everyone he can in a headquarters. He should keep a written record of who they are, their positions, and how to contact them. Otherwise, he will be overwhelmed by the number of people he meets. He will need to know these people to help him solve problems. Members of his own unit will ask for names and phone numbers so they can coordinate.
- An LO should send a copy of the visited headquarters' SOP to his unit as quickly as possible, especially report formats.
- If an LO attaches himself to the TOC watch officer and listens to what goes on (or fails to go on), he will be able to inform his unit of incoming missions. An LO is not only the official representative of his command, he is also a conduit of information for his commander.
- The LO must think about his unit's needs. He must be creative in looking for information, units, materiel, or other resources. He must ask, “Does my unit know about that? Will we have a need for it?”

- If the need arises, the LO must be prepared to comment on performance to watch officer or even the G3. If shortcomings hurt his unit and threaten its mission, he should inform the watch officer. He must have his facts straight, be professional, and speak in private.

- The LO should ask questions. He must demand explanations. Every resource the LO fails to tap for his parent unit because he is not dynamic or creative enough to grasp the importance and value of an item may cost a life or threaten the mission. The two questions that should always be on the LO's mind are, "How can I help my unit?" and "How can I help other units?"

Before departing his own unit, the LO should receive briefings on—

- His unit's mission.
- The current situation.
- The commander's intent and concept of operations including the following:
 - Unit locations.
 - A front-line trace.
 - A map with overlay.
 - Combat capabilities.
 - Task organization and changes in detail.
 - Contact points (and their effective times and call sign).
 - Boundary changes, and their effective times, and current higher and adjacent unit status.
 - Required road clearance.
 - Friendly air defense artillery positions.
- A unit estimate of enemy situation and locations, intent, and capabilities in sector.
- Transportation and destruction of classified documents.
- Communications, to ensure—
 - Radios work.
 - SOI complete.
 - Challenge and password for all adjacent units.
 - Variables for secure communication with parent unit.

- Transportation requirements.
- Language and interpreter requirements.
- Security *en route* to the unit.
- The current logistics situation.
- Special requirements.

Before departure from his unit, the LO must coordinate with the CofS, G3, or TOC officer for a final update and sign out of unit, giving his estimated time of arrival to the supported unit.

COMMAND POST DISPLACEMENT

Displacing a CP is a function of training and staff battle drills that each unit must accomplish within its resources and training schedule. Normally a command post does not shut down and transfer operations to another CP while it displaces.

Each CP in the division must be able to displace during tactical operations and simultaneously conduct its C² mission. The recommended method is for each CP to split and displace by echelon. When one echelon moves, it eavesdrops during the move while the remaining stationary echelon maintains functional operations. Once the moving echelon establishes itself in its new location, an exchange of only that critical information received during the move is passed by maneuver control system (MCS), mobile subscriber equipment (MSE), and frequency modulated (FM) to the displaced echelon. Once this echelon receives and understands the information, it accepts control and the remaining echelon moves to the new location or it may leapfrog to another location past the last jump site. The displacement of division CPs should cause minimal disruption to normal C² activities. During displacement operations, a CP should perform only those functions absolutely critical to support the battle or operation.

Each CP has sufficient vehicles and personnel on each shift to move by this technique. For example, in the TAC CP, the G2 vehicle and the FSE vehicle could form one echelon while the G3 and mobility and survivability (M/S) vehicle could form the second echelon. The command group vehicle can be temporarily added to the G3 and M/S echelon to provide a fire support capability. Both

echelons will, of necessity, perform reduced functions because of the doubling up of functions in each vehicle. Shift personnel can be split between echelons so that half the G3 M/S personnel function within the G2 FSE vehicles and vice versa.

Command post SOPs should determine the exact personnel breakout for command post element by shift, depending on current strength levels and authorizations. In this way, during a fast-moving offensive or defensive tactical situation, the CP can continue to perform its functions without losing its capability to continuously see the battlefield. During fast-paced offensive or defensive operations, the CP may have to perform continuously in the displacement mode to maintain contact with unit forces.

COMMAND POST SECURITY

Security of the CP takes many forms. Using MSE or other wire communications as the primary form of communications enhances electronic security. FM communications should be used only when the CP is displacing or is out of range of enemy medium artillery or electronic detection measures.

Physical security offers an entirely different set of problems. Command post security should not be confused with self-imposed requirements to limit access to the TOC. The physical security of any CP is enhanced by the use of camouflage nets. When time permits, maintaining a CP that is small in size and 100 percent mobile also enhances physical security. The use of concertina wire to improve physical security is *not* recommended unless the CP is in a static location for a

long period of time (as fire bases in Vietnam were). The use of wire requires extraordinary human efforts to correctly emplace small amounts to be effective.

The current technique of placing a single strand of wire around a CP is also inadequate. It is ineffective against a determined enemy agent or small force. In addition, the wire signals to the enemy that the CP it surrounds is probably important and makes it a high-value target. Wire also hinders the mobility of the CP's vehicles to displace rapidly when under the threat of direct or indirect fires. Physical security must begin well away from the CP with checkpoints, patrols, listening posts (LPs), and observations posts (OPs). The G3 operations sergeant major or senior NCO is normally in charge of physical security of the CP. Command post shift personnel cannot be expected to perform both their command post functional missions and security or guard missions and maintain a continuous operations capability.

A designated security force must be task-organized from available forces to support the CP. This security force can be infantry companies or platoons, a military police (MP) platoon augmented by the division band, or any other element available and capable of performing the security mission. The CP is too valuable to the division's operation to relegate its security to only two entrance guards checking TOC passes. If classified or sensitive information is discussed or used then the unit should control access to the TOC by using organic nonshift personnel for limited periods of time.

Section III. COMMAND POST FACILITIES

This section describes critical functions required by the TAC, main, and rear CPs to effectively command and control tactical operations. Additionally, it describes an assault command post. All descriptions of CP operations derive from the functional CP study and orient on the performance of critical C² functions rather than on specific, rigidly enforced CP configurations.

There is no requirement, nor should there be, to set up command posts in these configurations only. The terrain, AO, and tactical situation will determine the set-up configuration; however, the

functions performed always remain the same. This section identifies minimum quantities and types of key equipment and personnel required to perform critical C² functions continuously with two 12-hour shifts. The CP layouts are not intended to prescribe, but only to portray the equipment and space required to perform specified functions. The C² processes and techniques apply equally to light, air assault, and airborne divisions.

The L-series TOE is the basis for allocating assets to support critical C² functions. The

diagrams in this section acknowledge that differing MTOEs exist and the current L-series TOE does not authorize sufficient personnel and equipment to perform functions required by current doctrine and training literature. These diagrams do, however, reflect a realistic allocation of minimum equipment and personnel needed to effectively command and control a division in combat. The personnel diagrams reflect the minimum number of personnel required, but not necessarily authorized, by current MTOEs and TOEs. In some staff areas, bill payers have been identified from less critical functions. The personnel diagrams describe the duty position, proposed rank, number required, MOS required, and L-series TOE reference number from which the personnel were obtained. For those elements and functions for which no identified bill payers were found within the TOE, a blank space at the TOE reference number represents a critical personnel slot that should be filled with additional personnel to perform that function. It is recommended that units fill these personnel slots “out of hide” until TOEs are changed to accurately reflect realistic division C² requirements.

When the division is committed, the logistic support area should remain in the division’s rear area near the rear CP. There, the logistic support area, because of its size and lack of mobility, does not represent a security risk for the main CP. The logistic support area must support the main and tactical CPs by logistics packages specially tailored to meet CP requirements. The packages function in the same manner as in our brigades and battalions. Small, mobile contact teams will perform required or emergency maintenance to the CP. They will perform only essential maintenance or repairs until time and the situation permit a more sustained effort. The headquarters company of the DISCOM provides internal supply, food service, and unit-level maintenance for vehicles, generators, and construction equipment organic to the division rear CP.

THE TACTICAL COMMAND POST

During combat operations, the division tactical command post—

- Continuously supports the close operation by coordinating and synchronizing the immediate

tactical requirements of elements committed to the division close operations.

- Receives, posts, analyzes, and distributes combat information and tactical intelligence from higher, lower, and adjacent units to support the close operation.
- Synchronizes and expedites fires of all fire support assets supporting the close operation.
- Coordinates and integrates mobility and survivability operations (chemical and engineer obstacles) in support of the close operation.

As an extension of the main CP, the TAC CP moves well forward to focus its efforts on the close operation. As its name suggests, the TAC CP is a combat command element capable of operating close to combat maneuver elements and subject to engagement by the enemy’s direct or indirect fires. Well forward generally means in the vicinity of the lead or main effort brigade main CP, or even farther forward if the situation dictates. The TAC CP is properly positioned if it can “see the close battlefield.” The TAC CP is deployed to be in a position on the battlefield to manage and control those divisional forces committed or moving to close combat with an enemy force. It serves as a net control station (NCS) to receive brigade and separate battalion requests for support, and combat status reports. It makes critical, time-sensitive tactical decisions when required. It coordinates close operations requirements for support with the main CP.

The TAC CP is designed and manned to be a small, highly mobile and survivable command post. Its survivability is directly related to its small size and capability to rapidly displace. Only essential personnel and equipment should be located at the TAC CP. When deploying the TAC CP, *smaller is always better*. The following paragraphs describe a functionally based TAC CP design.

Figure 2-3 depicts two basic configurations used by the TAC CP when deployed. Either configuration, with extensions out, can be used when the TAC is established in a secure area with little probability of receiving enemy indirect fire and having to displace rapidly. The end-to-end configuration without extensions is used when the TAC CP is committed to controlling close

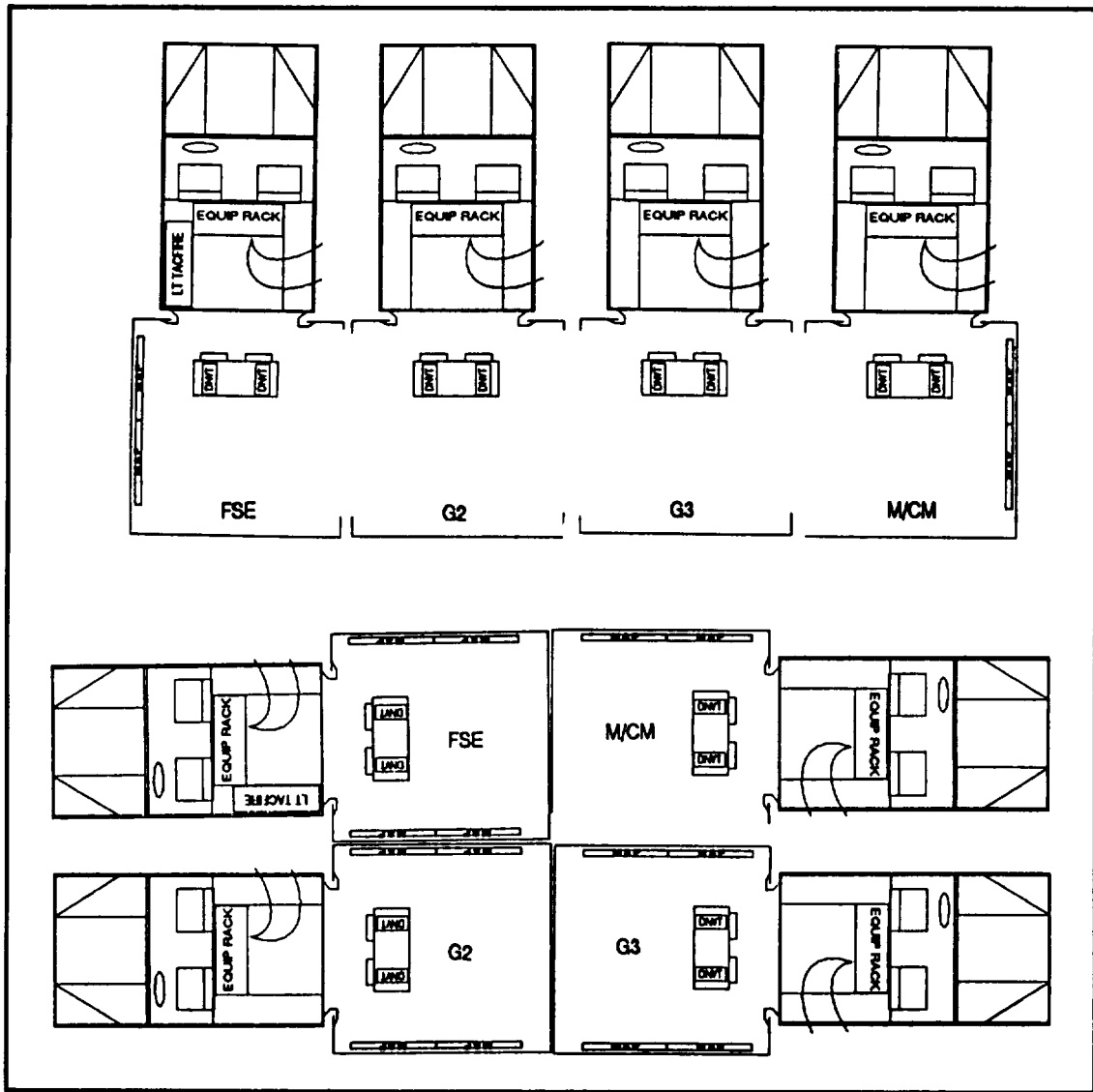

Figure 2.3. TAC CP deployment, side-by-side and back-to-back

operations and rapid displacement is essential to its survivability, or it must move frequently to keep up with fast-moving offensive or defensive tactical operations. In this situation, the G3 operations establish a rally point to which each vehicle moves after dispersing in different directions.

The TAC CP is not always deployed. It deploys when the division is committed to combat operations or must coordinate, synchronize, and

conduct a collateral operation, such as a passage of lines, river crossing, or relief in place.

When not required to deploy, the TAC CP remains near the main CP in a "warm" mode. When warm, the TAC CP is monitoring radio nets; MCS terminals are on, maintaining and compiling a current data base; operational maps are posted and updated as information changes. Personnel manning is at a minimum. Personnel

close by, however, maintain a high state of readiness to deploy "hot" when required.

To control and support the elements committed to the close operation, the TAC CP normally comprises five mutually supporting elements—the assistant division commander for maneuver (ADC-M), G3 operations, G2 operations, fire support element, and M/S element. The HMWWVS that make up the TAC CP are configured with redundant communications equipment and C² accessories to support continuous operations. Information is normally on 1:50,000 (or 1:100,000) scale maps and 1:250,000 scale maps.

The ADC-M

The ADC-M is a brigadier general who normally locates on the battlefield at the TAC CP

when it is deployed. The ADC-M must make on-the-spot decisions concerning all aspects of the close operation. He must make these decisions with an understanding of the division commander's intent and vision of how the battle should play out. He also relies on his firsthand and more immediate knowledge of the tactical situation and committed units' status. Although the ADC-M focuses on the close operation and committed units, he also knows the status of the deep and rear operations so that he can make tactical decisions for the close fight that will support those operations in the long term and benefit the overall division battle. The ADC-M is not required to seek permission from the main CP or commandgroup prior to making a tactical decision. He does, however, have to make that

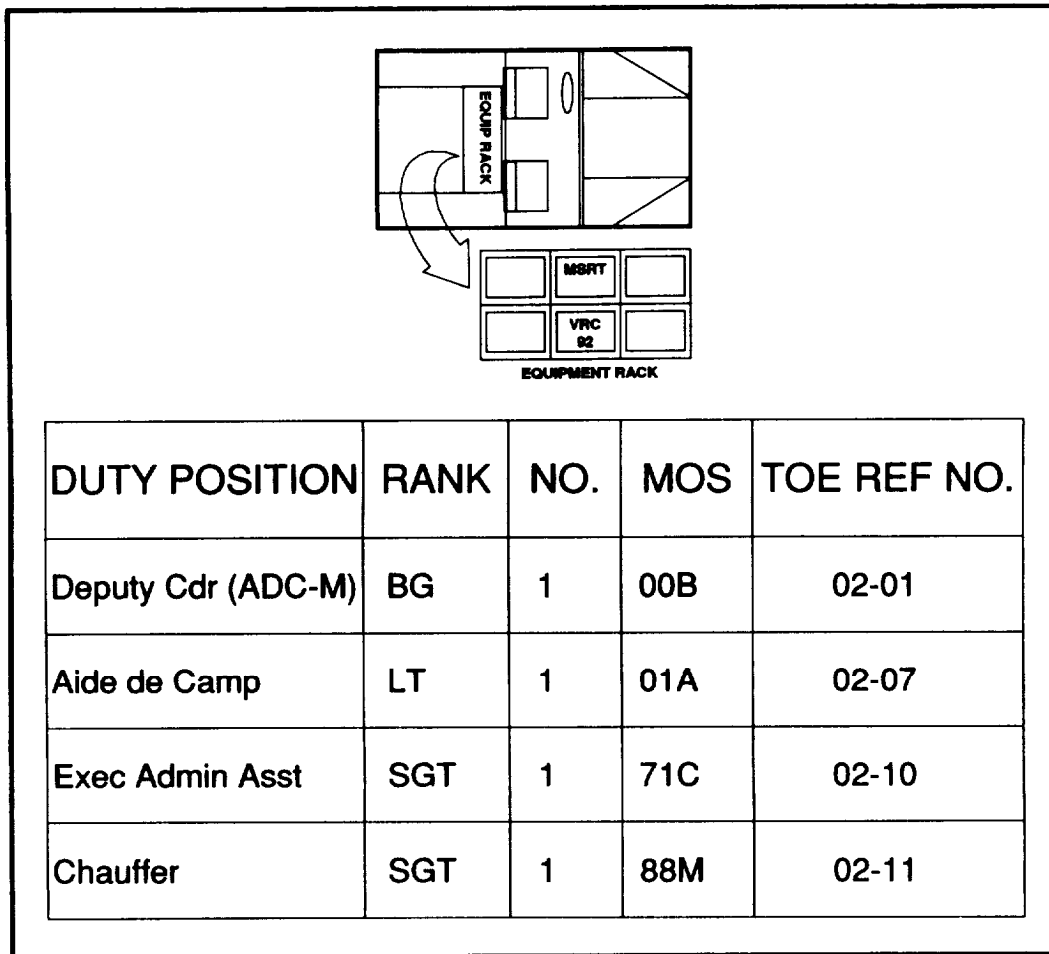

Figure 2-4. ADC-M equipment and personnel

decision known to the TAC CP and the main CP so that they can integrate and synchronize other supporting battlefield elements and redirect their support. He functions at the TAC CP with only his organic HMMWV (Figure 2-4). The HMMWV's communications package allows him to function far forward where he can physically see or influence a battle or to accompany a unit into a hostile environment.

The G3 Operations Element

The division G3 provides a G3 operations element as an extension of the main CP G3 operations element that helps make up the TAC CP. The G3 operations HMMWV is the command center and the operational hub of the TAC CP operations and is the controlling element of the TAC CP (Figure 2-5).

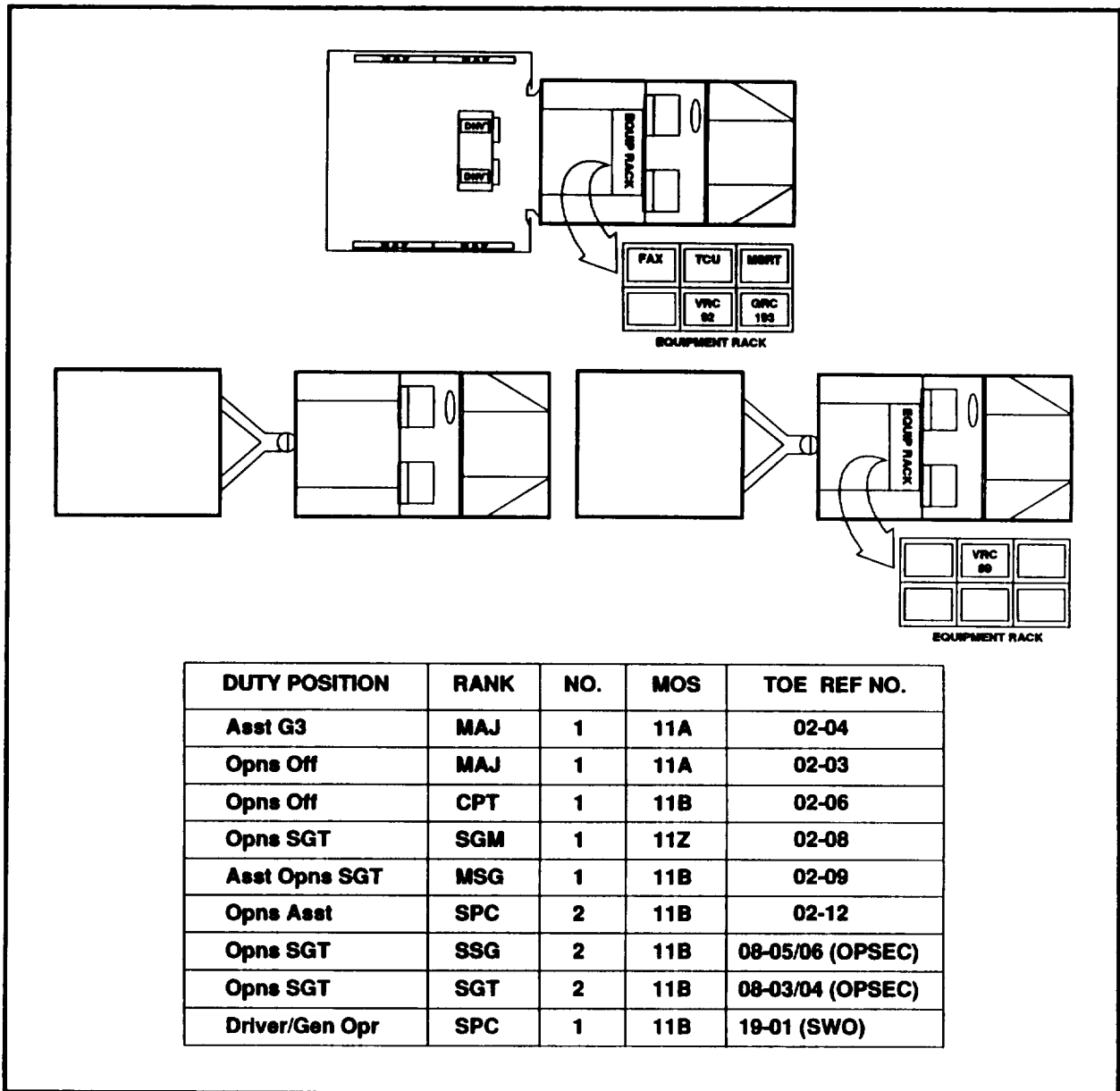

Figure 2.5. TAC CP G3 operations vehicle and personnel

The senior G3 operations NCO is responsible for the physical layout and overall functioning of the TAC CP. He establishes shift rosters, maintains security, performs maintenance on all vehicles, and controls access to the CP operations area. The G3 operations map is the focal point of all TAC CP operations and information-gathering activities. The primary task of the TAC CP G3 element is to provide and maintain the capability to see the close operation as it develops by acquiring the most accurate picture possible of the status and location of all committed elements. It establishes direct FM, AM, MSE, and MCS communications with committed brigades and separate battalions. It continually posts a current operations map with the last-known location or front-line trace and intentions of elements no smaller than battalion or squadron or separate company. Posting smaller elements becomes time-consuming, adds unnecessary clutter, and detracts from the G3's capability to see the battlefield clearly. Units should dictate a standard for map posting, but the general rule should be to post no lower than two levels down.

When the ADC-M or the commanding general is located at the TAC CP, he makes all tactical decisions that affect the close operation from the G3 operations map. The G3 operations at the TAC CP routinely sends updates to the main CP on unit locations. Resources requested by committed units are passed to the G3 operations at the main CP which allocates resources and establishes priorities based on the overall division battle. The G3 operations maps at the TAC and main CPS cannot and should not be identical because each has a differing focus, scope, and information time frame. Information critical to the TAC CP in controlling close operations may be of little value to the main CP as it assesses the overall division battle within the time window that it can affect. The G3 element at the TAC CP must resist attempts to redirect its focus from supporting committed forces.

The G3 section routinely receives and provides information to the TAC CPs of only those units committed to close operations. (The main CP handles all other units not committed to the

ELEMENT	CURRENT	PROJECTED	ELEMENT	CURRENT	PROJECTED
1st Bde	○	○	3rd Bde	○	○
INF Bn	○	○	INF Bn	○	○
INF Bn	○	○	INF Bn	○	○
INF Bn	○	○	INF Bn	○	○
FA Bn (DS)	○	○	AVN Bde	○	○
ENGR Co (DS)	○	○	ATK Bn	○	○
ADA Btry (DS)	○	○	ASLT Bn	○	○
1st FSB	○	○	DIVARTY	○	○
2d Bde	○	○	DISCOM	○	○
INF Bn	○	○	Div Troops		
INF Bn	○	○	CAV Sqdn	○	○
INF Bn	○	○	ENGR Bn (-)	○	○
FA Bn (DS)	○	○	ADA Bn	○	○
ENGR Co (DS)	○	○	MI Bn	○	○
ADA Btry (DS)	○	○	SIGNAL Bn	○	○
2d FSB	○	○	MP Co	○	○
	○	○	CML Co	○	○

Figure 2-6. Committed unit task organization and the commander's assessment

close operation.) From the maneuver standpoint, the TAC CP G3 operations map should routinely reflect the following:

- The frontline trace of battalion-sized units in contact.
- The center of mass of committed battalions not in contact.
- The committed brigade TAC and main CPs' current and proposed locations.
- Current maneuver graphics with control measures.
- The location of the reserve.
- The location of adjacent units.
- The location of the main and rear CPs.
- The decision support template.

The TAC CP G3 operations keeps only the minimum number of charts required to see the battlefield. The following charts are normally necessary to portray maneuver:

- The current mission and intent (in words).

- The task organization and commander's assessment (words and gumball).
- The MSC's critical maneuver systems assessment (gumball).

Figure 2-6 shows an example of a division TAC CP G3 operations task organization chart. It also reflects the current and projected combat capability of committed maneuver and combat support units. Only those units committed to close operations are monitored. Figure 2-7 shows more detail by critical weapons and CSS systems for each MSC.

These gumball charts effectively capture critical information about maneuver elements without a major expenditure of manpower. They highlight alarms without a great deal of analysis by the decision maker. For this system to work, however, each echelon must have a usable, workable common SOP. The demands of conflict may require some modification of what critical elements to monitor. The TAC CP should capture and track only information that allows it to see the close operation and respond rapidly to the requirements of elements committed to combat with the enemy.

ELEMENT	TOWs	NVDS	ATK MELO	ARTY	CL III	CL V	Para		Comments
1st Bde	<input type="checkbox"/>	<input type="checkbox"/>	<input type="checkbox"/>	<input type="checkbox"/>	<input type="checkbox"/>	<input type="checkbox"/>	<input type="checkbox"/>	<input type="checkbox"/>	
Bn	<input type="checkbox"/>	<input type="checkbox"/>	<input type="checkbox"/>	<input type="checkbox"/>	<input type="checkbox"/>	<input type="checkbox"/>	<input type="checkbox"/>	<input type="checkbox"/>	
Bn	<input type="checkbox"/>	<input type="checkbox"/>	<input type="checkbox"/>	<input type="checkbox"/>	<input type="checkbox"/>	<input type="checkbox"/>	<input type="checkbox"/>	<input type="checkbox"/>	
Bn	<input type="checkbox"/>	<input type="checkbox"/>	<input type="checkbox"/>	<input type="checkbox"/>	<input type="checkbox"/>	<input type="checkbox"/>	<input type="checkbox"/>	<input type="checkbox"/>	
2nd Bde	<input type="checkbox"/>	<input type="checkbox"/>	<input type="checkbox"/>	<input type="checkbox"/>	<input type="checkbox"/>	<input type="checkbox"/>	<input type="checkbox"/>	<input type="checkbox"/>	
Bn	<input type="checkbox"/>	<input type="checkbox"/>	<input type="checkbox"/>	<input type="checkbox"/>	<input type="checkbox"/>	<input type="checkbox"/>	<input type="checkbox"/>	<input type="checkbox"/>	
Bn	<input type="checkbox"/>	<input type="checkbox"/>	<input type="checkbox"/>	<input type="checkbox"/>	<input type="checkbox"/>	<input type="checkbox"/>	<input type="checkbox"/>	<input type="checkbox"/>	
Bn	<input type="checkbox"/>	<input type="checkbox"/>	<input type="checkbox"/>	<input type="checkbox"/>	<input type="checkbox"/>	<input type="checkbox"/>	<input type="checkbox"/>	<input type="checkbox"/>	
3d Bde	<input type="checkbox"/>	<input type="checkbox"/>	<input type="checkbox"/>	<input type="checkbox"/>	<input type="checkbox"/>	<input type="checkbox"/>	<input type="checkbox"/>	<input type="checkbox"/>	
Bn	<input type="checkbox"/>	<input type="checkbox"/>	<input type="checkbox"/>	<input type="checkbox"/>	<input type="checkbox"/>	<input type="checkbox"/>	<input type="checkbox"/>	<input type="checkbox"/>	
Bn	<input type="checkbox"/>	<input type="checkbox"/>	<input type="checkbox"/>	<input type="checkbox"/>	<input type="checkbox"/>	<input type="checkbox"/>	<input type="checkbox"/>	<input type="checkbox"/>	
Bn	<input type="checkbox"/>	<input type="checkbox"/>	<input type="checkbox"/>	<input type="checkbox"/>	<input type="checkbox"/>	<input type="checkbox"/>	<input type="checkbox"/>	<input type="checkbox"/>	
	<input type="checkbox"/>	<input type="checkbox"/>	<input type="checkbox"/>	<input type="checkbox"/>	<input type="checkbox"/>	<input type="checkbox"/>	<input type="checkbox"/>	<input type="checkbox"/>	
Avn Bde	<input type="checkbox"/>	<input type="checkbox"/>	<input type="checkbox"/>	<input type="checkbox"/>	<input type="checkbox"/>	<input type="checkbox"/>	<input type="checkbox"/>	<input type="checkbox"/>	
ATK Bn	<input type="checkbox"/>	<input type="checkbox"/>	<input type="checkbox"/>	<input type="checkbox"/>	<input type="checkbox"/>	<input type="checkbox"/>	<input type="checkbox"/>	<input type="checkbox"/>	
ASLT Bn	<input type="checkbox"/>	<input type="checkbox"/>	<input type="checkbox"/>	<input type="checkbox"/>	<input type="checkbox"/>	<input type="checkbox"/>	<input type="checkbox"/>	<input type="checkbox"/>	
Cav Sqdn	<input type="checkbox"/>	<input type="checkbox"/>	<input type="checkbox"/>	<input type="checkbox"/>	<input type="checkbox"/>	<input type="checkbox"/>	<input type="checkbox"/>	<input type="checkbox"/>	
	<input type="checkbox"/>	<input type="checkbox"/>	<input type="checkbox"/>	<input type="checkbox"/>	<input type="checkbox"/>	<input type="checkbox"/>	<input type="checkbox"/>	<input type="checkbox"/>	
	<input type="checkbox"/>	<input type="checkbox"/>	<input type="checkbox"/>	<input type="checkbox"/>	<input type="checkbox"/>	<input type="checkbox"/>	<input type="checkbox"/>	<input type="checkbox"/>	
	<input type="checkbox"/>	<input type="checkbox"/>	<input type="checkbox"/>	<input type="checkbox"/>	<input type="checkbox"/>	<input type="checkbox"/>	<input type="checkbox"/>	<input type="checkbox"/>	

Figure 2-7. Critical maneuver systems assessment

The G2 Operations Element

The G2 element at the TAC CP is an extension of the G2 operations element of the main CP and functions from a HMMWV (Figure 2-8). It exists solely to acquire and analyze intelligence gathered from the close operation and to provide current intelligence of value to committed units. The TAC CP G2 maintains communications with the S2s of maneuver brigades, separate battalions, and separate or special purpose intelligence-gathering companies. Tactical information is gathered from the individual soldier on up.

Each echelon providing information first analyzes data received and then forwards its

assessment of the enemy current status, location, and intentions to the next higher command post. For example, the G2 at the TAC CP should not receive spot reports such as "sighted three BMPs at NG631221" from an infantry squad (unless specially requested). Rather, he should receive "are engaging one MRR center of mass NG653236" from a brigade S2 that has analyzed information gathered from three or more battalion S2s who analyzed their information from companies, scout platoons, and forward observers. The TAC CP G2 should not post and analyze each intelligence spot report as that effort becomes more and more time-consuming as the battle progresses and volumes of data become available. Posting all the data a command post

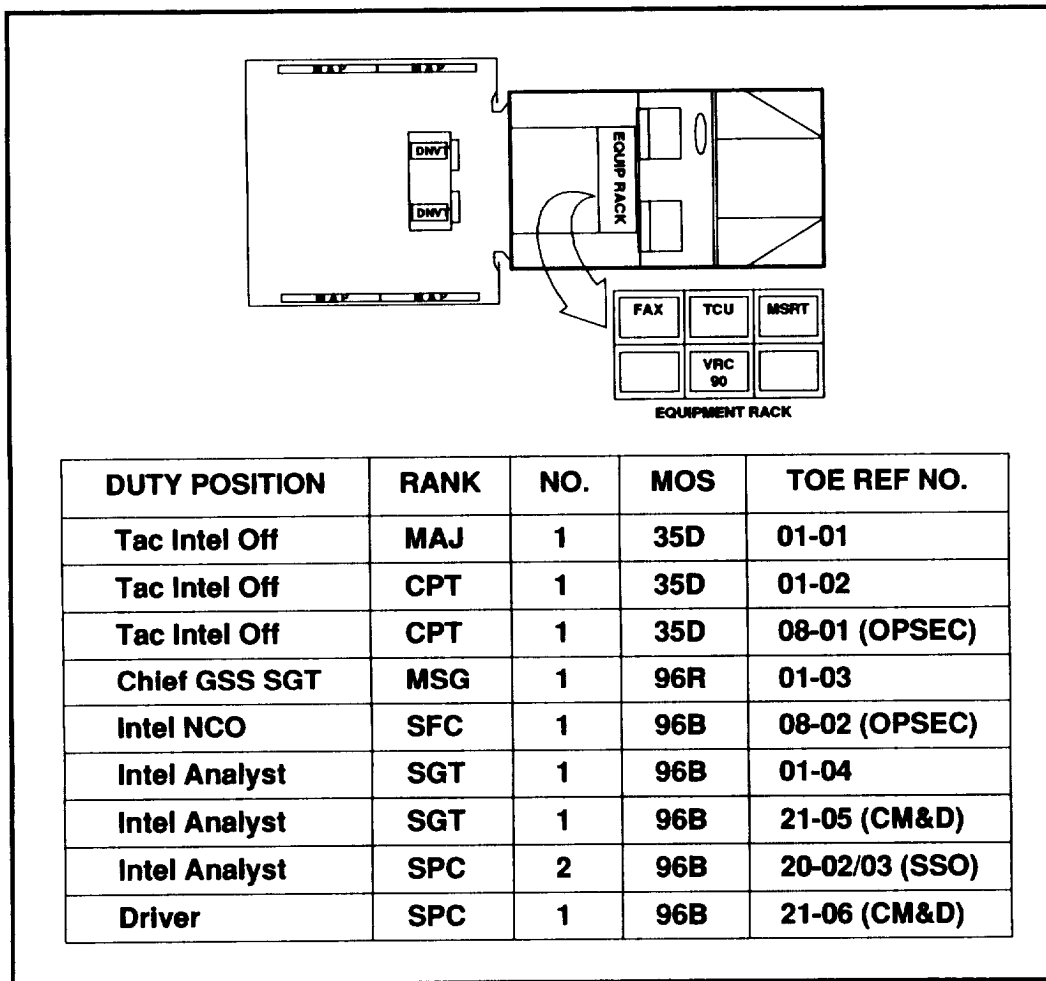

Figure 2.8. TAC CP G2 operations vehicles and personnel

receives can become monumental and all-consuming. The TAC CP G2 must be able to consistently see the battlefield intelligence of the close operation. After posting and analyzing intelligence products from committed units, the TAC CP G2 also provides an analyzed product or “best guess” to the G2 operations at the main CP.

This TAC CP information, when seen with other intelligence sources available to the main CP, enables the G2 at the main CP to get inside the enemy’s decision cycle by determining his tactical or operational intentions. Conversely, the G2 at the main CP must keep the TAC CP constantly informed about intelligence that will or may impact on the close operation. The TAC CP G2 passes intelligence requests and requirements from committed forces to the main CP G2. The latter establishes priorities and allocates available intelligence resources to support the close operation as well as the overall division battle.

The G2 at the TAC CP normally maintains two maps—a 1:50,000 scale map to support tactical operations and a 1:250,000 scale map to depict enemy follow-on forces and adjacent unit threats. The most important is the 1:50,000 intelligence operations map. The TAC CP G2 operations map should routinely depict the following intelligence information:

- The center of mass of reported enemy battalion and separate company-level combat and combat support unit locations.
- The frontline trace of enemy units.
- Suspected or confirmed enemy boundaries.
- The projected or confirmed enemy ground and air avenues of approach into the close operations area.
- Current friendly maneuver graphics and fire control measures.
- Named areas of interest (NAIs) and target areas of interest (TAIs) that affect close operations area.
- The location and range fan of intelligence collection and electronic warfare (EW) assets supporting the close operation.

The TAC CP G2 maintains a separate map for the G3. They are located in close proximity to

communicate and share information. The TAC CP G2 posts some specific enemy units on the G3 operations map to help orient on the enemy. Normally, enemy elements posted by the G2 on the G3 operations map consist of an enemy frontline trace and symbols that locate the enemy’s regiments, reconnaissance companies, field artillery (FA) battalions, and ADA batteries. Because each operations map maintained by G2 and G3 operations is standard in size and scale (with standard drops), the G2 can overlay the intelligence operations map onto the G3 operations map.

The TAC CP G2 should also maintain a *minimum* number of charts. *Time spent maintaining charts with no apparent value is time taken away from the analysis effort.* The TAC CP G2 maintains an enemy force kill board templated to reflect enemy force positions. Figure 2-9 provides an example of a kill board. The board arrays an enemy force as it is on the ground. The G2 can show the combat capability of an enemy unit by shading in the destroyed strength. The ADC-M can quickly assess the strength of the enemy while he looks at his current disposition on the operations map.

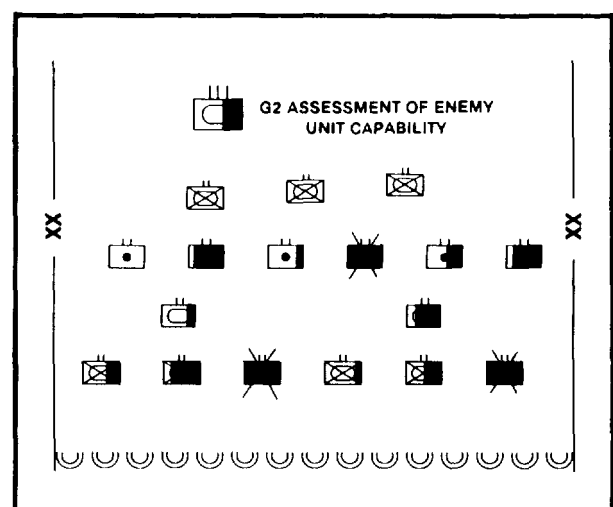

Figure 2-9. Example enemy kill board

Fire Support Element

The FSE at the TAC CP is also an extension of the main CP FSE. The TAC CP FSE comprises nine personnel (Figure 2-10). The TAC CP FSE

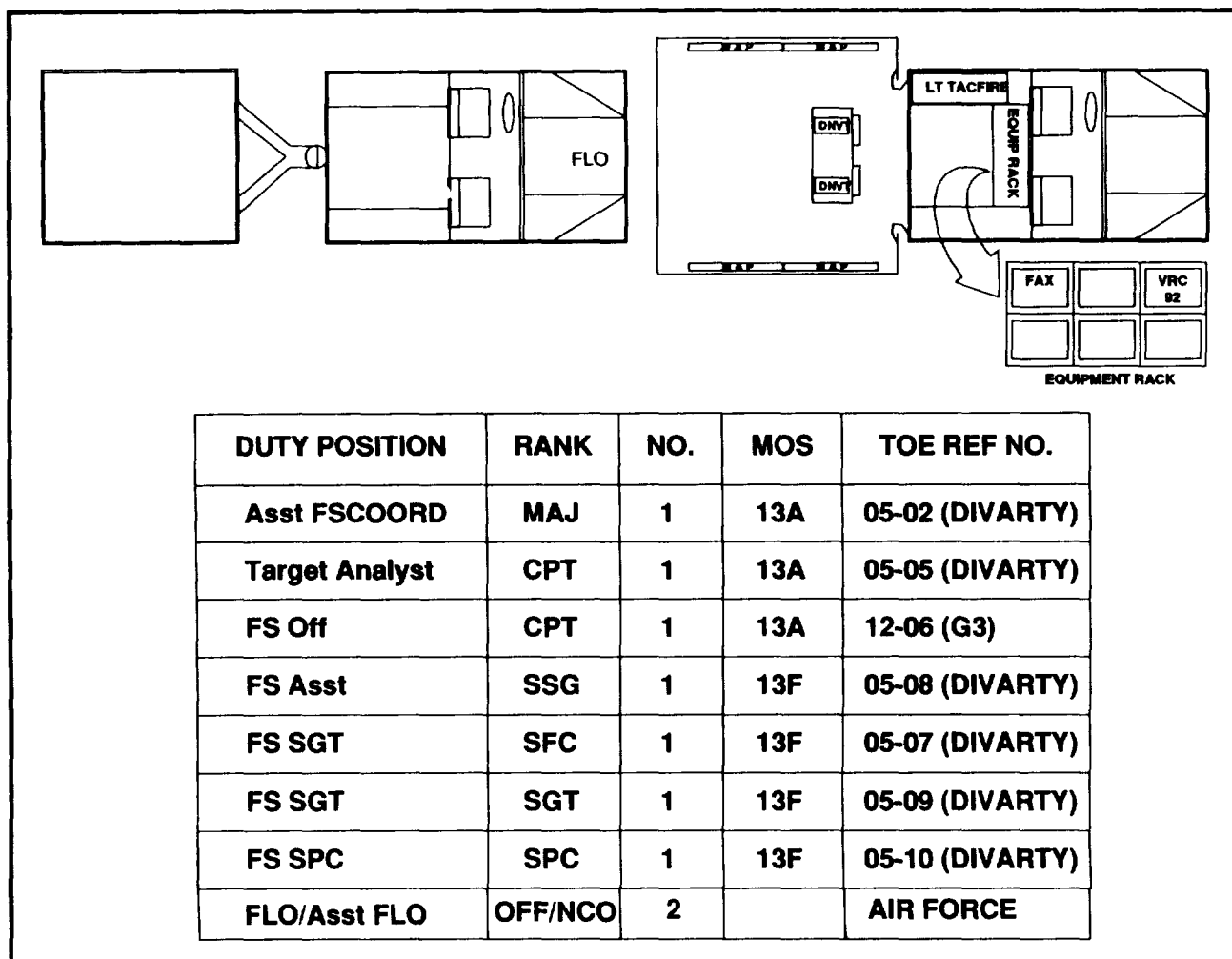

Figure 2-10. TAC CP FSE vehicle and personnel

coordinates fire support for current close operations. It coordinate and implements the fire support effort planned by the main CP FSE, responds to requests for additional fire support from subordinate FSEs, and identifies fire support requirements for the immediate and near-immediate tactical situations. A fighter liaison officer (FLO) resides in the FSE element. The FSE coordinates not only FA fires but also tactical air (TACAIR), offensive EW, and all other lethal and nonlethal fire support of the close operation. The TAC CP FSE maintains communications with subordinate FSEs and adjacent FSEs as required. It maintains the location and status of all fire support assets supporting close operations. The TAC CP FSE coordinates the priorities of fire support based on

decisions by the G3, ADC-M, or command group. It should not enmesh itself in the detailed workings of individual battalion or battery operations. The FSE should maintain the capability to see, anticipate, and react to the overall fire support battlefield in support of close operations.

The FSE at the TAC CP maintains one 1:50,000 scale fire support map. It should routinely depict—

- Maneuver graphics and control measures.
- Location of supporting artillery battalions and multiple launch rocket system (MLRS) battery.
- Location of supported unit fire support officers (FSOs).

- Location of DIVARTY and corps FA brigade main CPs.
- Division and corps fire support coordination graphics for the close operation.
- Ž Confirmed locations of enemy artillery units.
- Ž Airspace coordination measures.
- Supporting artillery unit's maximum range fans.
- Location of Q-36 and Q-37 radars and coverage fans.
- Location and coverage fans of nonlethal EW assets supporting close operations.
- Ž Location of adjacent, forward, or rearward fire support units supporting the close operation.

The TAC CP FSE should maintain only the minimum number of charts. The following charts are the norm to assist the FSE to see the close operation's battlefield:

- Fire support organization for combat.
- Ž High payoff target (HPT) list and target priorities.
- Ž Number of air sorties available.

The TAC CP FSE maintains estimates of the current and projected combat capability of FA assets by using the field artillery status gumball chart [shown at Figure 2-11). The FSEs at the main and rear CPs use the same chart. Information provided by the DIVARTY through their artillery-oriented commanders situation report updates it. The FSE, at the TAC CP, only monitors the status of FA units committed to the close operation. The maneuver brigade commander's situation report provides more information to the FSE. This includes the status of artillery units supporting that brigade. The FSE at the TAC CP posts all combat capability changes on its FA gumball chart; it passes the information to the FSE at the main CP and the G3 operations section. It updates FA information on the G3 maneuver gumball chart, if the information from artillery channels is more current than that received through maneuver channels.

The main CP FSE monitors the fire support requirements of the entire division battle. It also assists FSEs at the TAC and rear CPs by allocating resources and establishing priorities of fire support assets to best support current and future operations. The main CP FSE must maintain a completely accurate and up-to-date picture of the

ELEMENT	105/155 mm	8"	MLRS	Radar	TAC FIRE	CL III	CL V	Pers		Comments
DIVARTY	○	○	○	○	○	○	○	○		
___ FA Bn	○	○	○	○	○	○	○	○		
___ FA Bn	○	○	○	○	○	○	○	○		
___ FA Bn	○	○	○	○	○	○	○	○		
GS Btry	○	○	○	○	○	○	○	○		
MLRS Btry	○	○	○	○	○	○	○	○		
Tgt Acq Det	○	○	○	○	○	○	○	○		
Corps Bde	○	○	○	○	○	○	○	○		
___ FA Bn	○	○	○	○	○	○	○	○		
___ FA Bn	○	○	○	○	○	○	○	○		
___ FA Bn	○	○	○	○	○	○	○	○		
___ FA Bn	○	○	○	○	○	○	○	○		
___ FA Bn	○	○	○	○	○	○	○	○		

Figure 2-11. Field artillery status chart

division's fire support status. This enables the commander to reallocate priorities or support in response to situations in the battlefield.

Mobility and Survivability Element

The TAC CP is formed with an engineer element to support the M/S functions of the close operation. This element, comprised of engineer and chemical personnel, does not normally establish priorities or allocate resources for engineer or chemical elements, although a situation may require it to do so. This element works for the TAC CP G3 operations officer and synchronizes M/S operations in support of committed forces. Obstacles in the form of engineer or unit-

developed FASCAM routinely support the close operation. It is crucial that all obstacles (friendly and enemy) be identified and closely monitored to support branches of the current operation. Unknown obstacles are a liability on the battlefield. The magnitude of obstacle problems on the battlefield requires a dedicated effort to track location and status in synchronization with G3 operations. The engineer and chemical element works closely with the G2 and FSE to track known obstacles and plot them on the G3 operations map board. The engineer and chemical elements function out of the organic engineer battalion HMWWV located at the TAC CP. (Figure 2-12.)

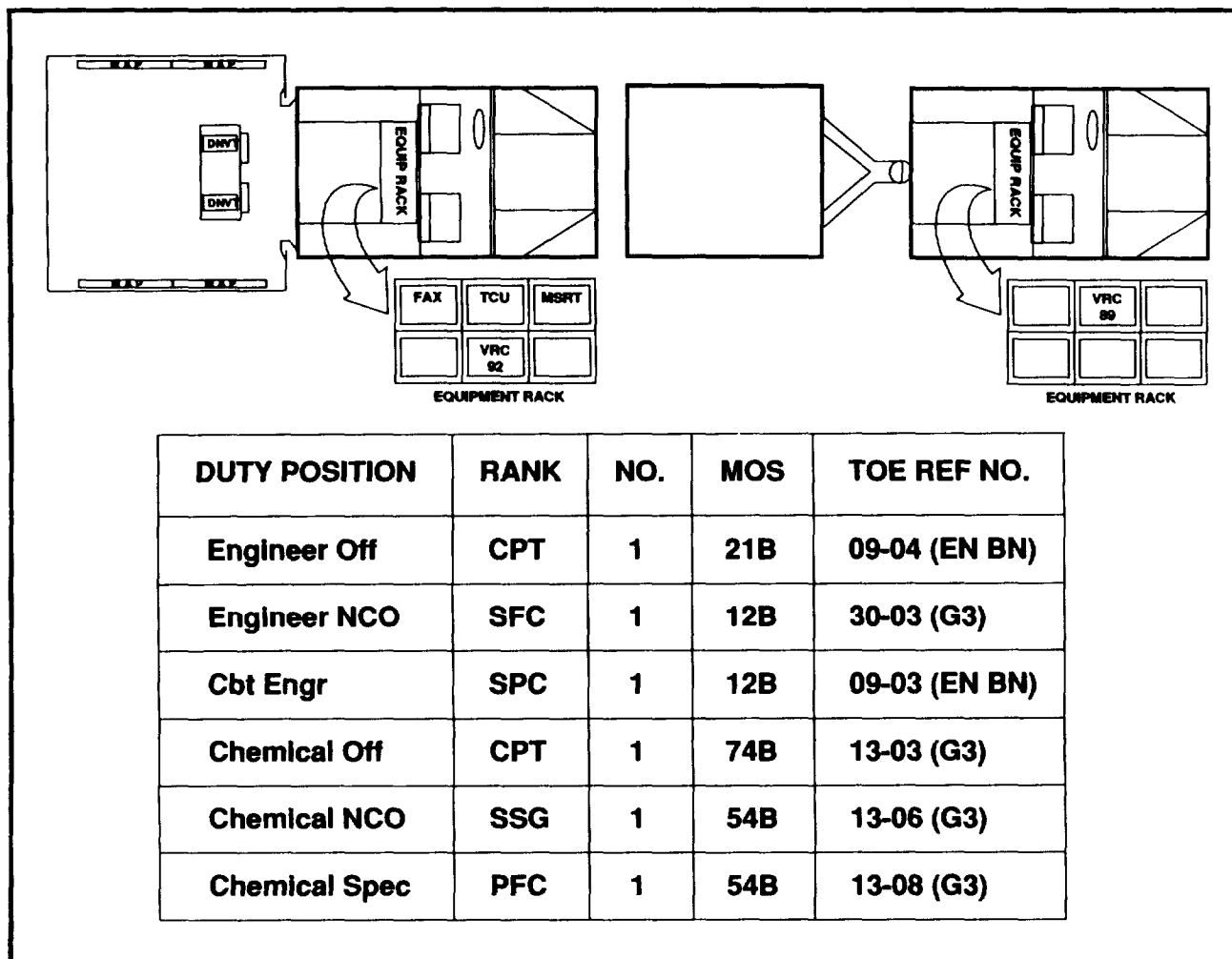

Figure 2.12. TAC CP mobility and survivability element vehicle and personnel

This element maintains a 1:50,000 scale map on which it posts all known obstacles in the close operations area—chemical, man-made (friendly and enemy), and natural. It maintains contact with committed forces and main CP engineer and chemical elements to remain up to date on the emplacement and destruction of friendly obstacles.

THE MAIN COMMAND POST

The main CP is the heartbeat of the division C² organization and structure. It maintains a pulse of all aspects of the division battle, receiving input from the TAC CP, rear CP, and higher, lower, and adjacent units. It maintains its ability to see the battlefield and makes plans and decisions that will affect committed forces several hours out. The main CP controls all units not specifically designated as being controlled by the TAC or rear CP. It is specifically designed, manned, and equipped to directly interface with all organic and supporting elements of the division. As such, the main CP is directly responsible for planning, coordinating, integrating, synchronizing, and establishing priorities, and allocating resources to support the division's simultaneous conduct of deep, close, and rear operations.

The main CP does not normally make decisions affecting the close operation because of its delay in receiving information. The time required for information to travel from the sender through several information-controlling conduits (headquarters) negates its value. The information does confirm or deny the CP's prediction of enemy intentions and the adequacy of the division's plan against the current threat. The main CP supports the division battle by responding to requests for support by committed and noncommitted units throughout the division area. It must focus equally on the three operations supporting the division battle. As decisions are made at the TAC CP or rear CP, the main CP "tidies up the battlefield" by conducting all coordination required by the decision rapidly and effectively.

The following paragraphs describe a functionally based main CP design. The main CP normally functions in a massed (Figure 2-13, page 2-32) configuration. The threat acquisition and

targeting capabilities, unit technology, and training will determine if the CP must disperse to survive. To function in the dispersed mode, the main CP must have the requisite computer and communications equipment that allow it to *electronically* collocate. Information at the main CP is normally displayed on 1:50,000 (or 1:100,000) scale maps and 1:250,000 scale maps.

The main CP contains three major functional cells: command cell, G3 cell, and G2 cell. All elements within the main CP function under the direct supervision, integration, or coordination of one of these three cells.

Command Cell

The command cell contains, and is responsible for the operation of, the command center and the commander's command group. The command center is an information and synchronization hub. It normally consists of the commanding general, CofS, secretary of the general staff (SGS), LOs, and supporting personnel and functions within the main CP from four standardized integrated command post system (SICPS) tents located in the center of the CP (Figure 2-14, page 2-33). The command center is the CofS's normal place of duty and the central source of information concerning the division's overall battle status. The CofS is the information manager for the division and the command center must be trained and structured to accomplish that function.

The command center is the eyes of the division for all information affecting deep, close, and rear operations. Briefings and staff huddles are held there to allow the staff to continue its routine work without excessive interference. The command center—

- Is the central repository of information concerning the conduct and status of the overall division battle.
- Synchronizes the functions of the main CP to support the entire division battle.
- Performs the role of information manager for division operations.
- Provides and accepts liaison teams.

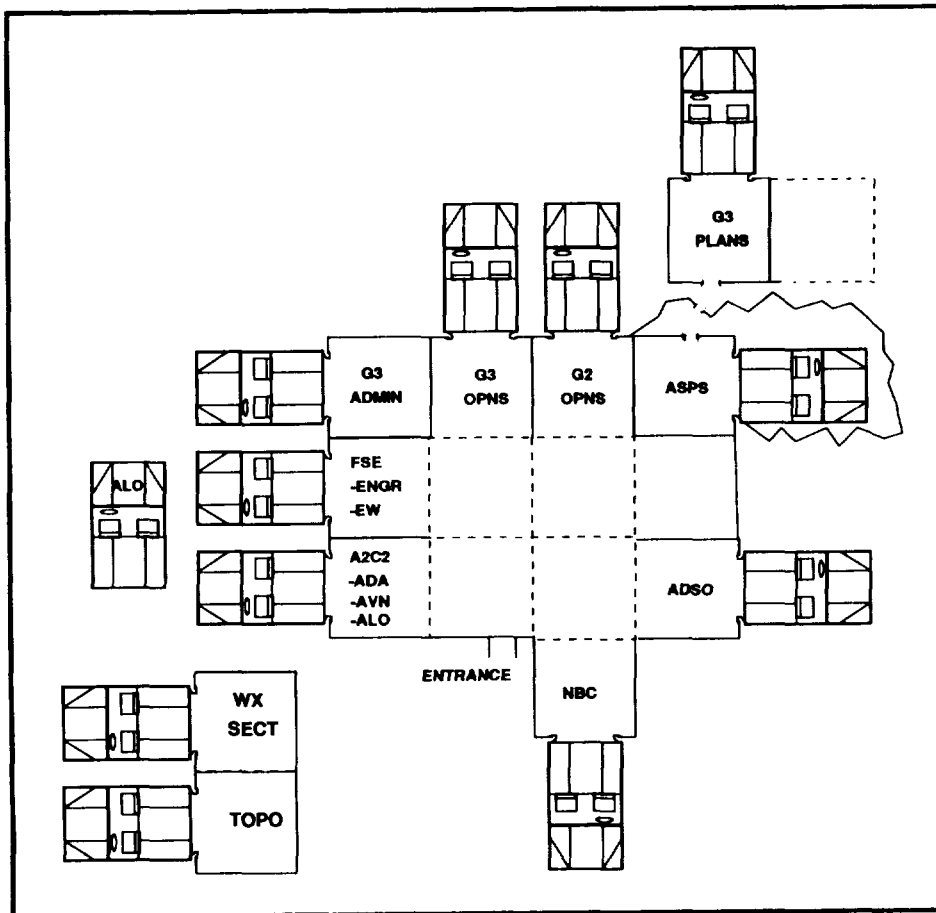

Figure 2-13. Main CP massed configuration

The effectiveness of the command center depends directly on the type and quality of information it obtains. Although it rarely makes close operations decisions, it coordinates and synchronizes decisions made at the TAC CP. Decisions about future operations and the posturing of forces that affect the overall battle are made in the command center.

All information enters the command center from the TAC and rear CPs through the coordinating staff in the main CP. Information enters the main CP from both the TAC and rear CPs, and flanking and higher units. Information from the TAC CP primarily relates to units committed to close combat. Rear CP information relates to the four functions of rear operations.

The display charts and tactical maps maintained within the command center should provide

an understandable visual picture of the total battlefield. They should enable the commander to initially see one echelon up and down. Any changes to the command center map and status boards are the responsibility of the CP's staff element. One person is usually placed in charge of the charts and maps. He is responsible for maintaining the currency of their information from data supplied by the staff. A conceptual representation of a command center information display array is shown at Figure 2-15, page 2-34.

Charts displayed within the command center should be kept to an absolute minimum. Routine command center information and the CCIR dictated by the commander determine the charts presented. These charts may differ for each unit depending on the commander's style of leadership and the factors of METT-T. However, they all

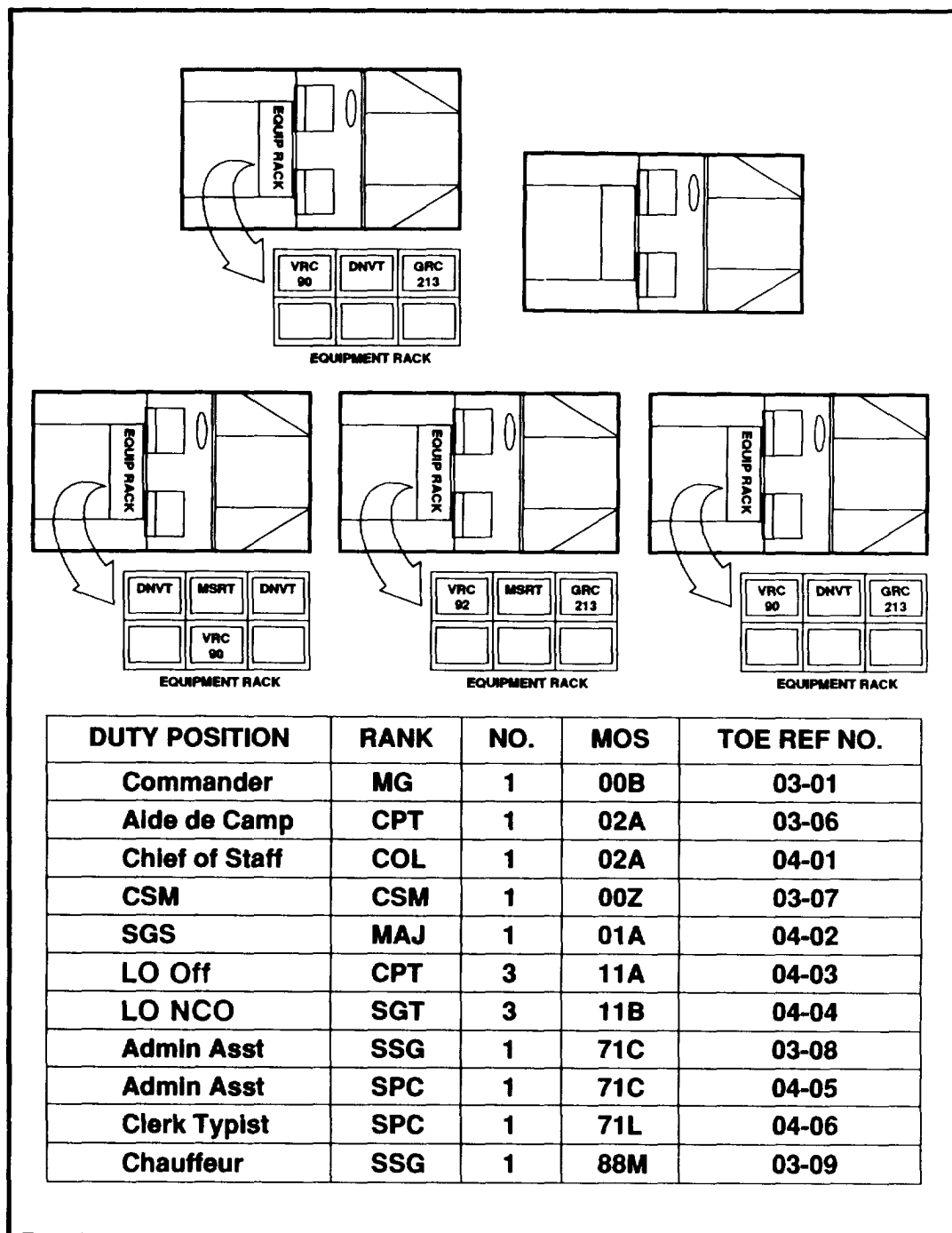

Figure 2-14. Command center personnel and vehicles

serve the same function; they support the commander's ability to see the battlefield. The staff and commander should determine the value of any additional chart (if any) to command center functions and critical decisions.

Used properly and with discipline, gumball charts can greatly reduce the need for word charts. They can present sufficient information for the higher level commander at the main CP to make decisions on current or future operations.

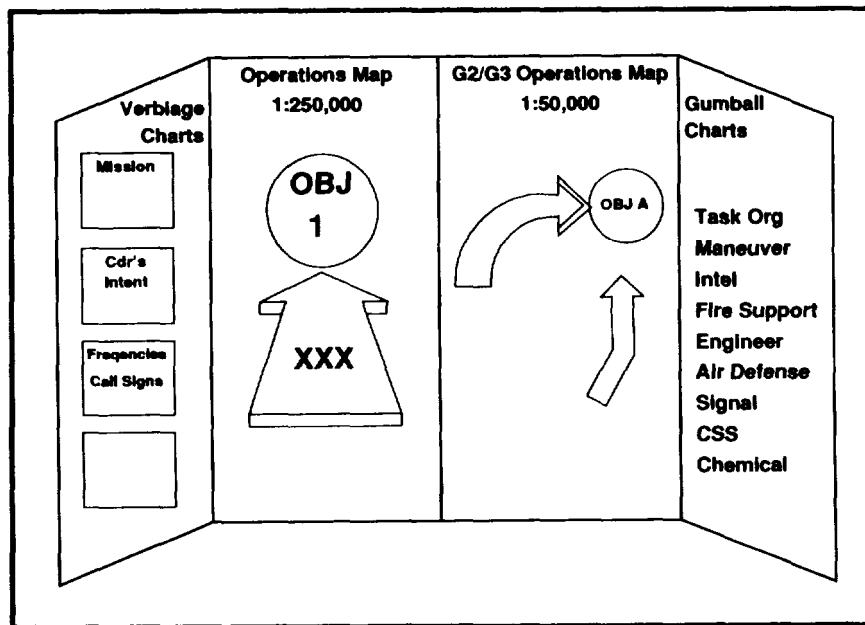

Figure 2-15. Command center information display

ELEMENT	CURRENT	PROJECTED	ELEMENT	CURRENT	PROJECTED
1st Bde	<input type="radio"/>	<input type="radio"/>	3rd Bde	<input type="radio"/>	<input type="radio"/>
INF Bn	<input type="radio"/>	<input type="radio"/>	INF Bn	<input type="radio"/>	<input type="radio"/>
INF Bn	<input type="radio"/>	<input type="radio"/>	INF Bn	<input type="radio"/>	<input type="radio"/>
INF Bn	<input type="radio"/>	<input type="radio"/>	INF Bn	<input type="radio"/>	<input type="radio"/>
FA Bn (DS)	<input type="radio"/>	<input type="radio"/>	AVN Bde	<input type="radio"/>	<input type="radio"/>
ENGR Co (DS)	<input type="radio"/>	<input type="radio"/>	ATK Bn	<input type="radio"/>	<input type="radio"/>
ADA Btry (DS)	<input type="radio"/>	<input type="radio"/>	ASLT Bn	<input type="radio"/>	<input type="radio"/>
1st FSB	<input type="radio"/>	<input type="radio"/>	DIVARTY	<input type="radio"/>	<input type="radio"/>
2d Bde	<input type="radio"/>	<input type="radio"/>	DISCOM	<input type="radio"/>	<input type="radio"/>
INF Bn	<input type="radio"/>	<input type="radio"/>	Div Troops		
INF Bn	<input type="radio"/>	<input type="radio"/>	CAV Sqdn	<input type="radio"/>	<input type="radio"/>
INF Bn	<input type="radio"/>	<input type="radio"/>	ENGR Bn	<input type="radio"/>	<input type="radio"/>
FA Bn (DS)	<input type="radio"/>	<input type="radio"/>	ADA Bn	<input type="radio"/>	<input type="radio"/>
ENGR Co (DS)	<input type="radio"/>	<input type="radio"/>	MI Bn	<input type="radio"/>	<input type="radio"/>
ADA Btry (DS)	<input type="radio"/>	<input type="radio"/>	SIGNAL Bn	<input type="radio"/>	<input type="radio"/>
2d FSB	<input type="radio"/>	<input type="radio"/>	MP Co	<input type="radio"/>	<input type="radio"/>
	<input type="radio"/>	<input type="radio"/>	CML Co	<input type="radio"/>	<input type="radio"/>

Figure 2-16. Task organization and unit current and projected status

Figure 2-16 shows an example of a commander's current and future assessment of major Army commands (MACOMs) using the task organization chart. Figures 2-17 through 2-24 show BOS

and functional elements assessment charts and critical elements that should be maintained and evaluated. These charts reflect only one level down, to the brigade and battalion levels. The

ELEMENT	TOWs	NVDS	ATK MELO	ARTY	CL III	CL V	Pers		Comments
1st Bde	<input type="checkbox"/>	<input type="checkbox"/>	<input type="checkbox"/>	<input type="checkbox"/>	<input type="checkbox"/>	<input type="checkbox"/>	<input type="checkbox"/>	<input type="checkbox"/>	
Bn	<input type="checkbox"/>	<input type="checkbox"/>	<input type="checkbox"/>	<input type="checkbox"/>	<input type="checkbox"/>	<input type="checkbox"/>	<input type="checkbox"/>	<input type="checkbox"/>	
Bn	<input type="checkbox"/>	<input type="checkbox"/>	<input type="checkbox"/>	<input type="checkbox"/>	<input type="checkbox"/>	<input type="checkbox"/>	<input type="checkbox"/>	<input type="checkbox"/>	
Bn	<input type="checkbox"/>	<input type="checkbox"/>	<input type="checkbox"/>	<input type="checkbox"/>	<input type="checkbox"/>	<input type="checkbox"/>	<input type="checkbox"/>	<input type="checkbox"/>	
2nd Bde	<input type="checkbox"/>	<input type="checkbox"/>	<input type="checkbox"/>	<input type="checkbox"/>	<input type="checkbox"/>	<input type="checkbox"/>	<input type="checkbox"/>	<input type="checkbox"/>	
Bn	<input type="checkbox"/>	<input type="checkbox"/>	<input type="checkbox"/>	<input type="checkbox"/>	<input type="checkbox"/>	<input type="checkbox"/>	<input type="checkbox"/>	<input type="checkbox"/>	
Bn	<input type="checkbox"/>	<input type="checkbox"/>	<input type="checkbox"/>	<input type="checkbox"/>	<input type="checkbox"/>	<input type="checkbox"/>	<input type="checkbox"/>	<input type="checkbox"/>	
Bn	<input type="checkbox"/>	<input type="checkbox"/>	<input type="checkbox"/>	<input type="checkbox"/>	<input type="checkbox"/>	<input type="checkbox"/>	<input type="checkbox"/>	<input type="checkbox"/>	
3d Bde	<input type="checkbox"/>	<input type="checkbox"/>	<input type="checkbox"/>	<input type="checkbox"/>	<input type="checkbox"/>	<input type="checkbox"/>	<input type="checkbox"/>	<input type="checkbox"/>	
Bn	<input type="checkbox"/>	<input type="checkbox"/>	<input type="checkbox"/>	<input type="checkbox"/>	<input type="checkbox"/>	<input type="checkbox"/>	<input type="checkbox"/>	<input type="checkbox"/>	
Bn	<input type="checkbox"/>	<input type="checkbox"/>	<input type="checkbox"/>	<input type="checkbox"/>	<input type="checkbox"/>	<input type="checkbox"/>	<input type="checkbox"/>	<input type="checkbox"/>	
Bn	<input type="checkbox"/>	<input type="checkbox"/>	<input type="checkbox"/>	<input type="checkbox"/>	<input type="checkbox"/>	<input type="checkbox"/>	<input type="checkbox"/>	<input type="checkbox"/>	
	<input type="checkbox"/>	<input type="checkbox"/>	<input type="checkbox"/>	<input type="checkbox"/>	<input type="checkbox"/>	<input type="checkbox"/>	<input type="checkbox"/>	<input type="checkbox"/>	
Avn Bde	<input type="checkbox"/>	<input type="checkbox"/>	<input type="checkbox"/>	<input type="checkbox"/>	<input type="checkbox"/>	<input type="checkbox"/>	<input type="checkbox"/>	<input type="checkbox"/>	
ATK Bn	<input type="checkbox"/>	<input type="checkbox"/>	<input type="checkbox"/>	<input type="checkbox"/>	<input type="checkbox"/>	<input type="checkbox"/>	<input type="checkbox"/>	<input type="checkbox"/>	
ASLT Bn	<input type="checkbox"/>	<input type="checkbox"/>	<input type="checkbox"/>	<input type="checkbox"/>	<input type="checkbox"/>	<input type="checkbox"/>	<input type="checkbox"/>	<input type="checkbox"/>	
Cav Sqdn	<input type="checkbox"/>	<input type="checkbox"/>	<input type="checkbox"/>	<input type="checkbox"/>	<input type="checkbox"/>	<input type="checkbox"/>	<input type="checkbox"/>	<input type="checkbox"/>	
	<input type="checkbox"/>	<input type="checkbox"/>	<input type="checkbox"/>	<input type="checkbox"/>	<input type="checkbox"/>	<input type="checkbox"/>	<input type="checkbox"/>	<input type="checkbox"/>	
	<input type="checkbox"/>	<input type="checkbox"/>	<input type="checkbox"/>	<input type="checkbox"/>	<input type="checkbox"/>	<input type="checkbox"/>	<input type="checkbox"/>	<input type="checkbox"/>	
	<input type="checkbox"/>	<input type="checkbox"/>	<input type="checkbox"/>	<input type="checkbox"/>	<input type="checkbox"/>	<input type="checkbox"/>	<input type="checkbox"/>	<input type="checkbox"/>	

Figure 2-17. Critical maneuver systems status chart

supporting staff sections maintain a “smart book” of information concerning elements two levels down. This supports the summaries presented in the command center.

A critical function of the command center is the accepting and dispatching of LOs. LOs can

represent adjacent, attached, or OPCON units at the main CP. The CofS supervises all LO activities in support of the division. The LOs may work out of the command center if room is available or the division may erect a tent near the entrance to the CP. (See page 2-17 for liaison officer duties and responsibilities.)

ELEMENT	Team Mate	Trail Blazer	Team Pack	Traffic Jam	Quick Fix	GSR	CL III	CL V	Pers	Comments
Div MI Bn	<input type="checkbox"/>	<input type="checkbox"/>	<input type="checkbox"/>	<input type="checkbox"/>	<input type="checkbox"/>	<input type="checkbox"/>	<input type="checkbox"/>	<input type="checkbox"/>	<input type="checkbox"/>	
Corps MI	<input type="checkbox"/>	<input type="checkbox"/>	<input type="checkbox"/>	<input type="checkbox"/>	<input type="checkbox"/>	<input type="checkbox"/>	<input type="checkbox"/>	<input type="checkbox"/>	<input type="checkbox"/>	

Figure 2-18. Critical intelligence systems status chart

ELEMENT	Arty	St Trk	MLRS	Tgt Radar	TAC FIRE	CL III	CL V	Pers	COMMENTS
DIVARTY	<input type="checkbox"/>	<input type="checkbox"/>	<input type="checkbox"/>	<input type="checkbox"/>	<input type="checkbox"/>	<input type="checkbox"/>	<input type="checkbox"/>	<input type="checkbox"/>	
Corps Arty	<input type="checkbox"/>	<input type="checkbox"/>	<input type="checkbox"/>	<input type="checkbox"/>	<input type="checkbox"/>	<input type="checkbox"/>	<input type="checkbox"/>	<input type="checkbox"/>	
Corps Arty	<input type="checkbox"/>	<input type="checkbox"/>	<input type="checkbox"/>	<input type="checkbox"/>	<input type="checkbox"/>	<input type="checkbox"/>	<input type="checkbox"/>	<input type="checkbox"/>	
	<input type="checkbox"/>	<input type="checkbox"/>	<input type="checkbox"/>	<input type="checkbox"/>	<input type="checkbox"/>	<input type="checkbox"/>	<input type="checkbox"/>	<input type="checkbox"/>	

Figure 2-19. Critical field artillery systems status chart

ELEMENT	ACE	SEE	VOLCANO	BRIDGE	CL III	CL IV	CL V	PERS	Sr TRK	COMMENTS
Div Engr Bn	<input type="radio"/>	<input type="radio"/>	<input type="radio"/>	<input type="radio"/>	<input type="radio"/>	<input type="radio"/>	<input type="radio"/>	<input type="radio"/>	<input type="radio"/>	
Corps Engr	<input type="radio"/>	<input type="radio"/>	<input type="radio"/>	<input type="radio"/>	<input type="radio"/>	<input type="radio"/>	<input type="radio"/>	<input type="radio"/>	<input type="radio"/>	
	<input type="radio"/>	<input type="radio"/>	<input type="radio"/>	<input type="radio"/>	<input type="radio"/>	<input type="radio"/>	<input type="radio"/>	<input type="radio"/>	<input type="radio"/>	

Figure 2-20. Critical engineer systems status chart

ELEMENT	Stinger	Avenger (Vulcan)	Chap	CL III	CL V	Pers	COMMENTS
Div ADA Bn	<input type="radio"/>	<input type="radio"/>	<input type="radio"/>	<input type="radio"/>	<input type="radio"/>	<input type="radio"/>	
Corps ADA	<input type="radio"/>	<input type="radio"/>	<input type="radio"/>	<input type="radio"/>	<input type="radio"/>	<input type="radio"/>	
	<input type="radio"/>	<input type="radio"/>	<input type="radio"/>	<input type="radio"/>	<input type="radio"/>	<input type="radio"/>	

Figure 2.21. Critical air defense systems status chart

ELEMENT	PDDE-H	PDDE-L	Smoke Gen	Recon Vehicle	CL III Fogoll	Pers	COMMENTS
Div NBC	<input type="radio"/>	<input type="radio"/>	<input type="radio"/>	<input type="radio"/>	<input type="radio"/>	<input type="radio"/>	
Corps CML Unit	<input type="radio"/>	<input type="radio"/>	<input type="radio"/>	<input type="radio"/>	<input type="radio"/>	<input type="radio"/>	
Corps CML Unit	<input type="radio"/>	<input type="radio"/>	<input type="radio"/>	<input type="radio"/>	<input type="radio"/>	<input type="radio"/>	

Figure 2-22. Critical NBC systems status chart

ELEMENT	MSE	TACSAT	HF	FM	MCS	FAX			Comments
Div Sig Bn	<input type="radio"/>	<input type="radio"/>	<input type="radio"/>	<input type="radio"/>	<input type="radio"/>	<input type="radio"/>	<input type="radio"/>	<input type="radio"/>	
A Co	<input type="radio"/>	<input type="radio"/>	<input type="radio"/>	<input type="radio"/>	<input type="radio"/>	<input type="radio"/>	<input type="radio"/>	<input type="radio"/>	
B Co	<input type="radio"/>	<input type="radio"/>	<input type="radio"/>	<input type="radio"/>	<input type="radio"/>	<input type="radio"/>	<input type="radio"/>	<input type="radio"/>	
C Co	<input type="radio"/>	<input type="radio"/>	<input type="radio"/>	<input type="radio"/>	<input type="radio"/>	<input type="radio"/>	<input type="radio"/>	<input type="radio"/>	
Corps Sig Elm	<input type="radio"/>	<input type="radio"/>	<input type="radio"/>	<input type="radio"/>	<input type="radio"/>	<input type="radio"/>	<input type="radio"/>	<input type="radio"/>	
Corps Sig Elm	<input type="radio"/>	<input type="radio"/>	<input type="radio"/>	<input type="radio"/>	<input type="radio"/>	<input type="radio"/>	<input type="radio"/>	<input type="radio"/>	
Corps Sig Elm	<input type="radio"/>	<input type="radio"/>	<input type="radio"/>	<input type="radio"/>	<input type="radio"/>	<input type="radio"/>	<input type="radio"/>	<input type="radio"/>	
	<input type="radio"/>	<input type="radio"/>	<input type="radio"/>	<input type="radio"/>	<input type="radio"/>	<input type="radio"/>	<input type="radio"/>	<input type="radio"/>	

Figure 2-23. Critical signal systems status chart

ELEMENT	CL I	CL I (water)	CL III	CL V	CL VIII	Fuel Haul	Cargo Haul	HET	Pers	COMMENTS
DISCOM	○	○	○	○	○	○	○	○	○	
MSB	○	○	○	○	○	○	○	○	○	
1st FSB	○	○	○	○	○	○	○	○	○	
2d FSB	○	○	○	○	○	○	○	○	○	
3d FSB	○	○	○	○	○	○	○	○	○	
	○	○	○	○	○	○	○	○	○	

Figure 2-24. Critical CSS systems status chart

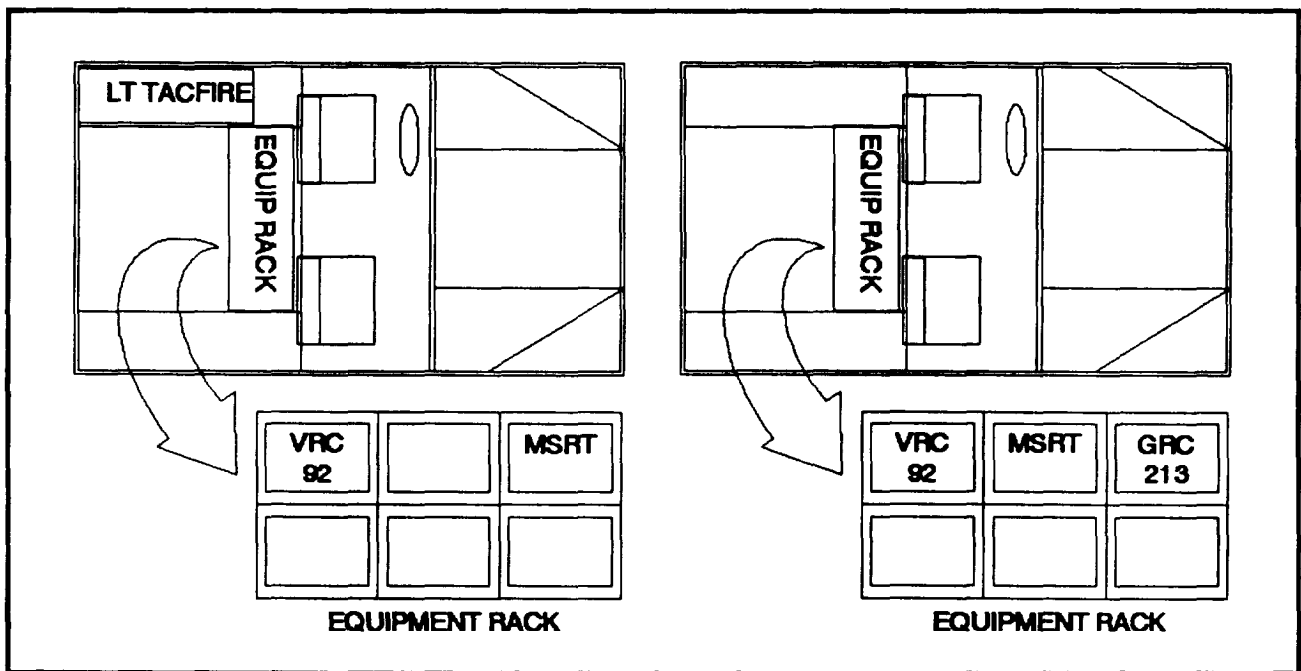

Figure 2.25. Command group vehicles

The *command group* is provided to the division commander for protection in movements in the forward areas of the battlefield. Two HMMWVs are configured with FM, AM, and MSE communications equipment. They allow the commander to command well forward where his presence can be seen and felt and he can make timely decisions based on his personal observation of the close operation (Figure 2-25).

The manning of the command group is a unit decision normally stated in the SOP. As a matter of technique, the command group should be minimally manned with a G3 officer or an operations NCO, a G2 officer or an NCO, a fire support officer or an NCO, and the FLO, if required. Decisions made by the commander at the command group is quickly relayed to the TAC and main CPs to begin staff coordination and synchronization.

G3 Cell

The division G3 cell, located at the main CP, is the synchronization hub for the division battle. It is the most important staff element supporting the division tactical operations. The G3 cell normally comprises these elements—G3 operations, G3 plans, A²C², fire support, assistant division signal officer (ADSO), and NBC. Also performing functions within the G3 section are representatives with a habitual relationship from the ADA battalion, engineer battalion, G1/G4, aviation brigade, and Air Force. The G3 cell is manned by approximately 85 personnel for continuous 24-hour operations.

Success on the division battlefield depends on its ability to fight according to the five basic doctrinal tenets of initiative, agility, versatility, depth, and synchronization. Synchronization of the many facets of the division battle is the most important function of the G3 section at the main CP. The G3 arranges battlefield activities in time, space, and purpose to produce maximum combat power at the right place and time. Within the main CP, the G3 has 24-hour access to representatives of each BOS—intelligence, maneuver, M/S, fire support, air defense, C², and CSS. With the exception of intelligence and CSS, BOS representatives work for and respond directly to the G3 in support of their synchronization responsibilities. Through these BOS representatives in the main CP, the G3 develops a common base for grouping subordinate activities. Time is the most critical element in synchronizing current and future operations.

The division G3 must routinely work out of the main CP. To win the division battle requires the full synchronization of all organic and supporting combat, CS, and CSS systems. Only the main CP is designed and structured to provide the G3 staff, functions, and command and control hardware required to see the complete division battlefield and synchronize deep, close, and rear operations. At the main CP, the G3 operates by moving between the G3 current operations and the command center. The G3 works closely with the CofS in coordinating tactical operational requirements of the division. The G3 should not position himself at the TAC CP. Here he will see

and control only the maneuver aspects of the close operation, essentially neglecting his responsibilities to the equally important rear and deep operations; critical collateral operations such as targeting, and suppression of enemy air defenses (SEAD); and future operations planning. Synchronization of the division battle requires the G3 to orchestrate the various elements within the main CP so that they can anticipate events and place assets at the right place at the right time.

G3 Operations Element

The G3 operations element is the primary asset with which the G3 sees the battlefield and executes his battle synchronization requirements. The G3 operations element—

- Coordinates, integrates, and synchronizes organic and supporting combat, CS, and CSS assets to support current and future deep, close, and rear combat operations for the division.
- Allocates resources and establishes priorities in support of the division battle.
- Prepares and issues warning and FRAGOs to support the current operation.
- Coordinates and conducts deep operations in support of close and rear operations.
- Monitors the operations of higher, lower, and flank units.
- Monitors close and rear operations.

The G3 operations element works out of a HMMWV and SICPS tent within the main CP (Figure 2-26). Operationally, the G3 operations element serves as the net control station for the division. It responds to communications from the TAC CP, rear CP, and noncommitted combat and CS units. The G3 operations element maintains current combat situation data, as received from the TAC CP for friendly forces. In the conduct of the current operation, it prepares and issues FRAGOs, develops branches to current operations, and coordinates the allocation of resources and establishment of priorities by other G3 elements and the G2 cell. It works closely with the plans element to synchronize future operations and the transition from the current operation to a

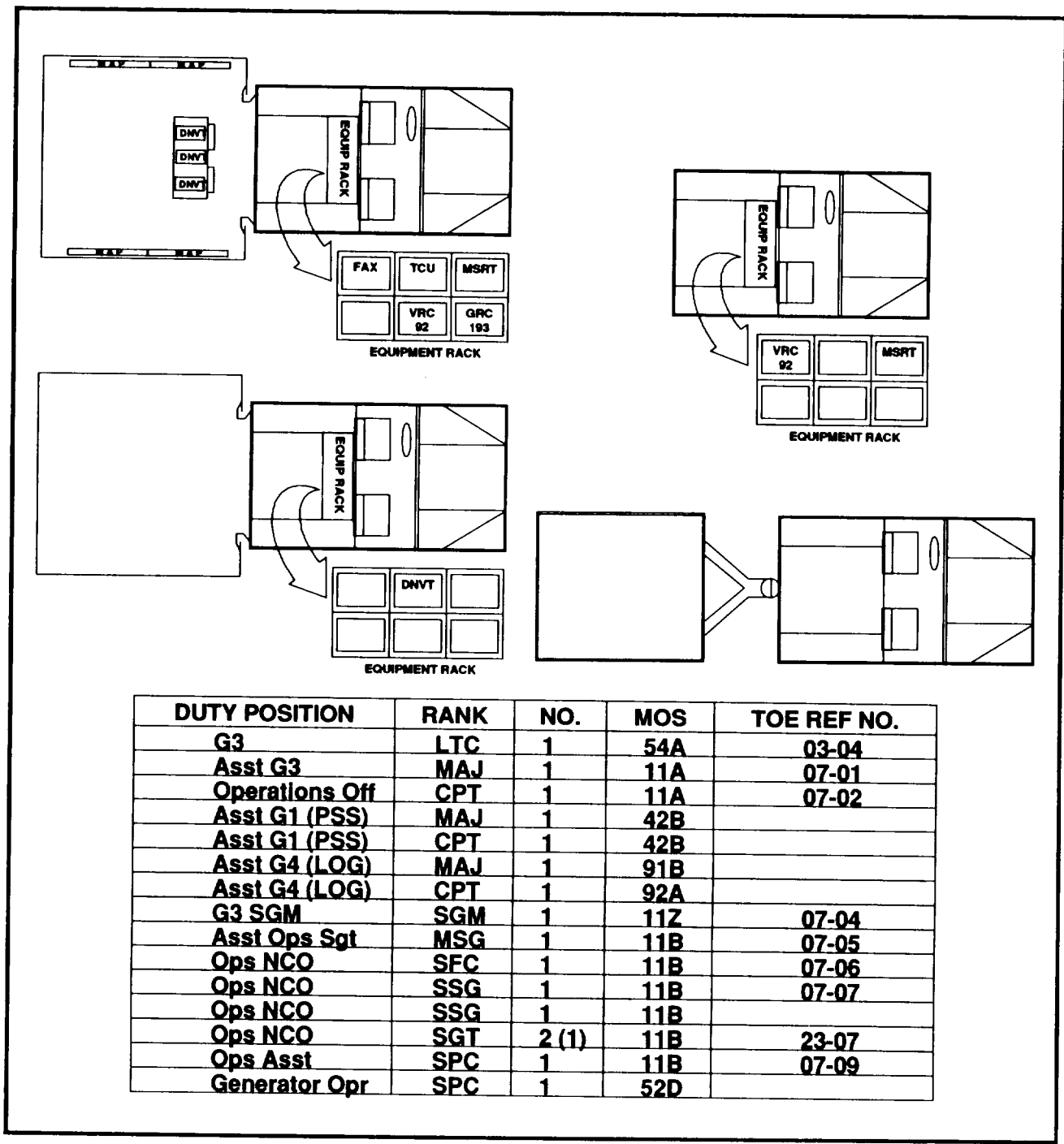

Figure 2-26. G3 operations cell vehicle and personnel

future division battle without loss of momentum and unit tactical integrity. When necessary, the G3 operations element synchronizes and controls the division's deep operations. Working with the

TAC and rear command posts G3 elements, the G3 operations element at the main CP manages the terrain assigned to the division for the conduct of tactical operations.

The G3 operations element functions primarily with current operations requirements within short-term time frames. A 1:250,000 map is maintained by the G3 operations element to post information from corps adjacent units and LOs that involves information outside the division current AO in the division area of interest. The G3 operations element maintains one 1:50,000 scale current operations map of the division AO. The operations map depicts current maneuver graphics, the location of TAC and rear CPs, the current committed force locations (at battalion level), and the frontline trace. It also displays the decision support template and locations of major enemy units and brigade and separate battalion CPs. This map becomes the focal point of G3 current operations capability to see the friendly battlefield. The G3 operations element must also transfer this picture to the tactical situation map in the command center, but with less detail. Both maps are posted with only the minimal essential information to reduce the clutter that builds up on a map. Normally, unit locations and status are not reported to the division main CP G3 operations element below the battalion and separate company level.

All tactical information contained on the main CP G3 current operations map is historical in nature and thus cannot be used for tactical

maneuver decisions. Those must be made at the TAC CP. The information presented does, however, confirm or deny the adequacy of the division's plan and allows the development of branches to the division battle plan if required. Maneuver unit status is maintained by colored gumball charts that reflect the relative combat status and capability of all maneuver units. This chart is identical to the one used by the TAC CP G3 operations (Figure 2-27).

Requests for support by the TAC CP, rear CP, and combat units not committed to close operations are immediately passed to the G3 and CofS for decision. They are then coordinated with the CP staff element responsible for the overall coordination, synchronization, and integration of that BOS in the current and future operation. The BOS of maneuver is the specific responsibility of the G3 operations cell.

Working for G3 operations are representatives of the G1 and G4. The timely integration of personnel replacements and logistics activities with changes to the current operations is critical to the division's success. These G1 and G4 representatives function as G3 operations officers. They are the main CP's direct link to the CSS operations cell in the rear CP for responding to immediate tactical requirements

ELEMENT	TOWS	NVDs	ATK HELO	ARTY	CL III	CL V	PERS	COMMENTS
1ST BDE	○	○	○	○	○	○	○	
2D BDE	○	○	○	○	○	○	○	
3rd BDE	○	○	○	○	○	○	○	
AVN BDE	○	○	○	○	○	○	○	
CAV SQDN	○	○	○	○	○	○	○	
	○	○	○	○	○	○	○	
	○	○	○	○	○	○	○	

Figure 2-27. Critical maneuver systems assessment

and coordinating personnel and logistics support for a future operation.

The G1 and G4 representatives in the G3 operations element do not maintain formal information presentations. However, they do

have access to G3 operations communications facilities, and communicate with the G1 and G4 at the rear CP. Through this dialogue, they maintain and update the CSS status chart (Figures 2-28 and 29) located in the command center.

Time	Overall Status	Pers	Equip	CL III	CL V	CL VIII	Maint	HSS	Other Supplies	Svcs	Trans	
Last 24 Hrs	<input type="checkbox"/>	<input type="checkbox"/>	<input type="checkbox"/>	<input type="checkbox"/>	<input type="checkbox"/>	<input type="checkbox"/>	<input type="checkbox"/>	<input type="checkbox"/>	<input type="checkbox"/>	<input type="checkbox"/>	<input type="checkbox"/>	<input type="checkbox"/>
Curr 24 Hrs	<input type="checkbox"/>	<input type="checkbox"/>	<input type="checkbox"/>	<input type="checkbox"/>	<input type="checkbox"/>	<input type="checkbox"/>	<input type="checkbox"/>	<input type="checkbox"/>	<input type="checkbox"/>	<input type="checkbox"/>	<input type="checkbox"/>	<input type="checkbox"/>
Next 24 Hrs	<input type="checkbox"/>	<input type="checkbox"/>	<input type="checkbox"/>	<input type="checkbox"/>	<input type="checkbox"/>	<input type="checkbox"/>	<input type="checkbox"/>	<input type="checkbox"/>	<input type="checkbox"/>	<input type="checkbox"/>	<input type="checkbox"/>	<input type="checkbox"/>
24 - 48 Hrs	<input type="checkbox"/>	<input type="checkbox"/>	<input type="checkbox"/>	<input type="checkbox"/>	<input type="checkbox"/>	<input type="checkbox"/>	<input type="checkbox"/>	<input type="checkbox"/>	<input type="checkbox"/>	<input type="checkbox"/>	<input type="checkbox"/>	<input type="checkbox"/>
48 - 72 Hrs	<input type="checkbox"/>	<input type="checkbox"/>	<input type="checkbox"/>	<input type="checkbox"/>	<input type="checkbox"/>	<input type="checkbox"/>	<input type="checkbox"/>	<input type="checkbox"/>	<input type="checkbox"/>	<input type="checkbox"/>	<input type="checkbox"/>	<input type="checkbox"/>
72 - 96 Hrs	<input type="checkbox"/>	<input type="checkbox"/>	<input type="checkbox"/>	<input type="checkbox"/>	<input type="checkbox"/>	<input type="checkbox"/>	<input type="checkbox"/>	<input type="checkbox"/>	<input type="checkbox"/>	<input type="checkbox"/>	<input type="checkbox"/>	<input type="checkbox"/>
	<input type="checkbox"/>	<input type="checkbox"/>	<input type="checkbox"/>	<input type="checkbox"/>	<input type="checkbox"/>	<input type="checkbox"/>	<input type="checkbox"/>	<input type="checkbox"/>	<input type="checkbox"/>	<input type="checkbox"/>	<input type="checkbox"/>	<input type="checkbox"/>
Remarks												

Figure 2-28. CSS status chart

Element	KIA	WIA	MIA	Seriously ill/Injured	Special Interest	Other
1st Bde						
2d Bde						
3d Bde						
Avn Bde						
Cav Sqdn						
Other						
Total						

Figure 2.29. Cumulative casualty status

G3 Plans Element

There is only one plans element within the division CP structure; it is located in the main CP. The plans cell is equipped and manned to—

- Conduct parallel planning with the G2 and G3 elements to facilitate transitioning from current operations to implementing future operations plans.
- Plan, integrate, coordinate, and synchronize all BOS into future operations.

- Produce operations plans (OPLANs), FRAGOs, and warning orders to support transition to future operations.

- Continuously monitor current operations to anticipate and adjust future planning requirements.

The plans element consists of sufficient personnel and equipment to perform continuous planning operations (Figure 2-30).

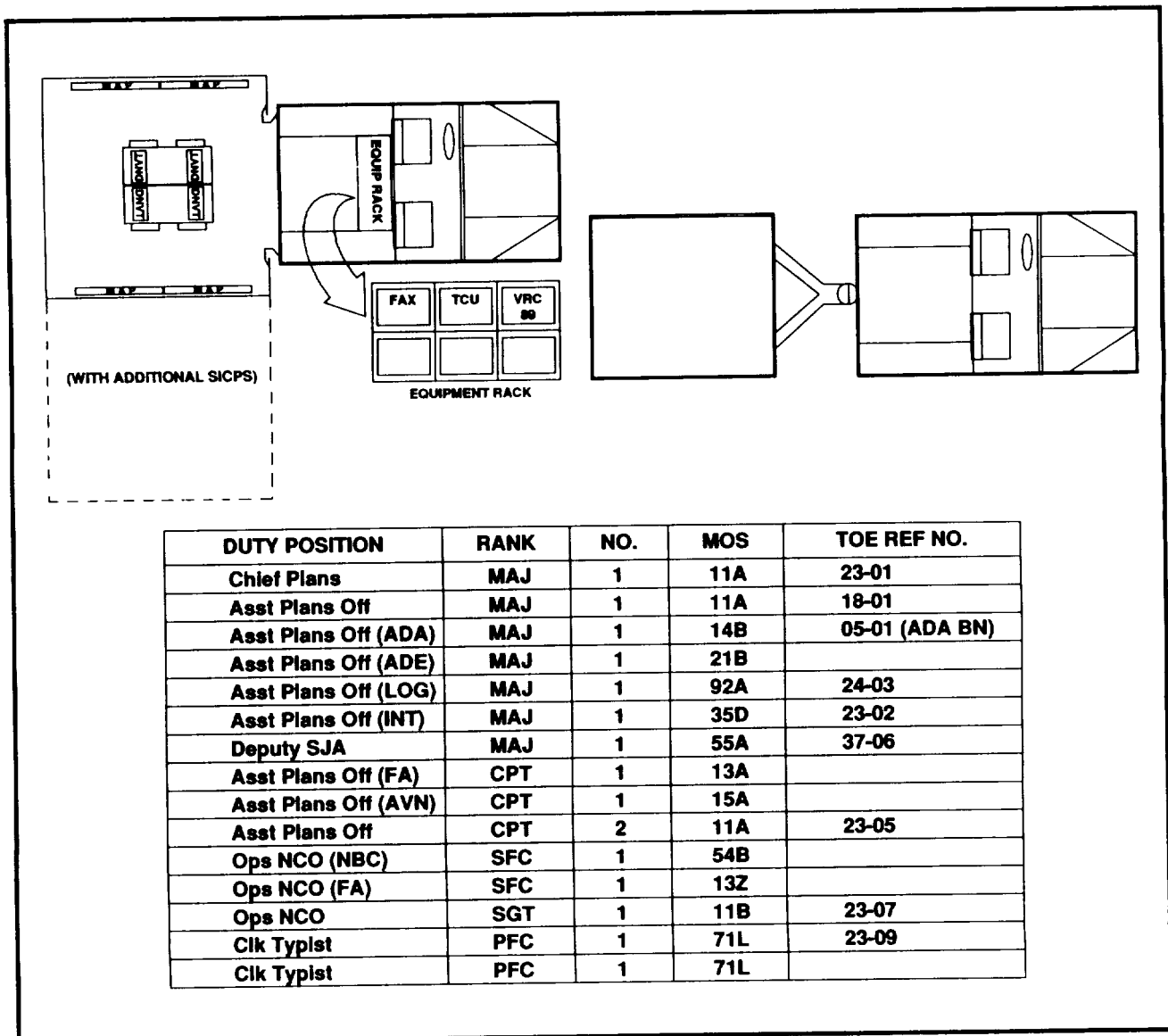

Figure 2-30. Plans element vehicle and personnel

A²C² Element

The division A²C² element in the main CP coordinates, integrates, and regulates division airspace. It functions from within a G3 HMMWV and SICPS tent with sufficient personnel for continuous operations (Figure 2-31, page 2-44). It normally locates adjacent to the FSE to allow continuous, critical, and face-to-face coordination for effective functioning of the two cells. The A²C² element monitors deep, close, and rear operations continuously. It also deconflicts division airspace for using TACAIR support, Army aviation, unmanned aerial vehicles (UAVs), ADA, FA, and EW assets. The A²C² cell—

- Coordinates airspace within the division's AO to support tactical and logistics operations.

- Integrates and coordinates Air Force and Army tactical air support for deep, close, and rear operations.

- Integrates, coordinates, and synchronizes the division's organic and supporting ADA assets in support of the division's battle.

The A²C² element works directly for and responds to taskings by the G3. It consists of the G3 air, an air defense coordination section, an aviation brigade section, and an Air Force TACP. Personnel from these staff sections and subordinate units collocate within the A²C² to perform full-time A²C² functions. They routinely accomplish two separate, but interrelated tasks. First, they integrate, coordinate, and synchronize their BOS or parent or supporting units into the division's current and future operations. Second, they assist the G3 air in the A²C² process by synchronizing the airspace requirements of their parent units with the airspace users supporting the division. All sections performing functions within the A²C² element support and respond to the G3 air. It, in turn, is responsible to the G3 for operations of the A²C² element. The G3 air ensures that the airspace over the division's entire AO is appropriately coordinated, integrated, and synchronized to support deep, close, and rear operations.

The A²C² element coordinates and controls the division's airspace through interface with the corps air traffic control center (ATC) and G3 elements at the TAC and rear CPs. The A²C²

element maintains current data on air traffic service (ATS) facilities, current and planned airspace restrictive measures, and special joint use requirements. The G3 resolves conflicts regarding divisional airspace use that command guidance, orders, and SOPs cannot resolve. He provides hostile air activity data obtained through the G2 and air defense channels to other elements of the CP.

With the supporting ATS unit at corps, the A²C² element develops plans to provide ATS assistance to aircraft operating within the division's AO and to units conducting tactical operations. The corps ATS unit supporting the division is linked with the A²C² system, the host nation's ATS, and the tactical air control system (TACS). The ATS system supports aircraft of other component forces operating in the division's AO, and divisional aviation brigade units conducting tactical operations. It is also the interface between aircraft in flight and the A²C² element at the CP. ATS support includes—

- Navigational assistance.
- Air threat warnings.
- Weather information.
- Notice to airmen.
- Artillery advisories.

Airfield and landing site terminal control.

Other assistance required to ensure near real-time coordination and integration of air traffic.

The A²C² element disseminates this information directly to the appropriate airspace users and ATS facilities.

Aircrews routinely monitor ATS frequencies and may request flight assistance, including flight following and current information on weather, NBC, airspace restrictions, and ongoing friendly air operations. When necessary, the division commander may direct mandatory flight following for all aircraft within the division's AO. Flight following may be accomplished with an aviation unit's organic flight operations section or with an ATS facility. Division A²C² cells coordinate with the corps A²C² element; corps coordinates the input of its subordinate units. The A²C² element also recommends air corridors to

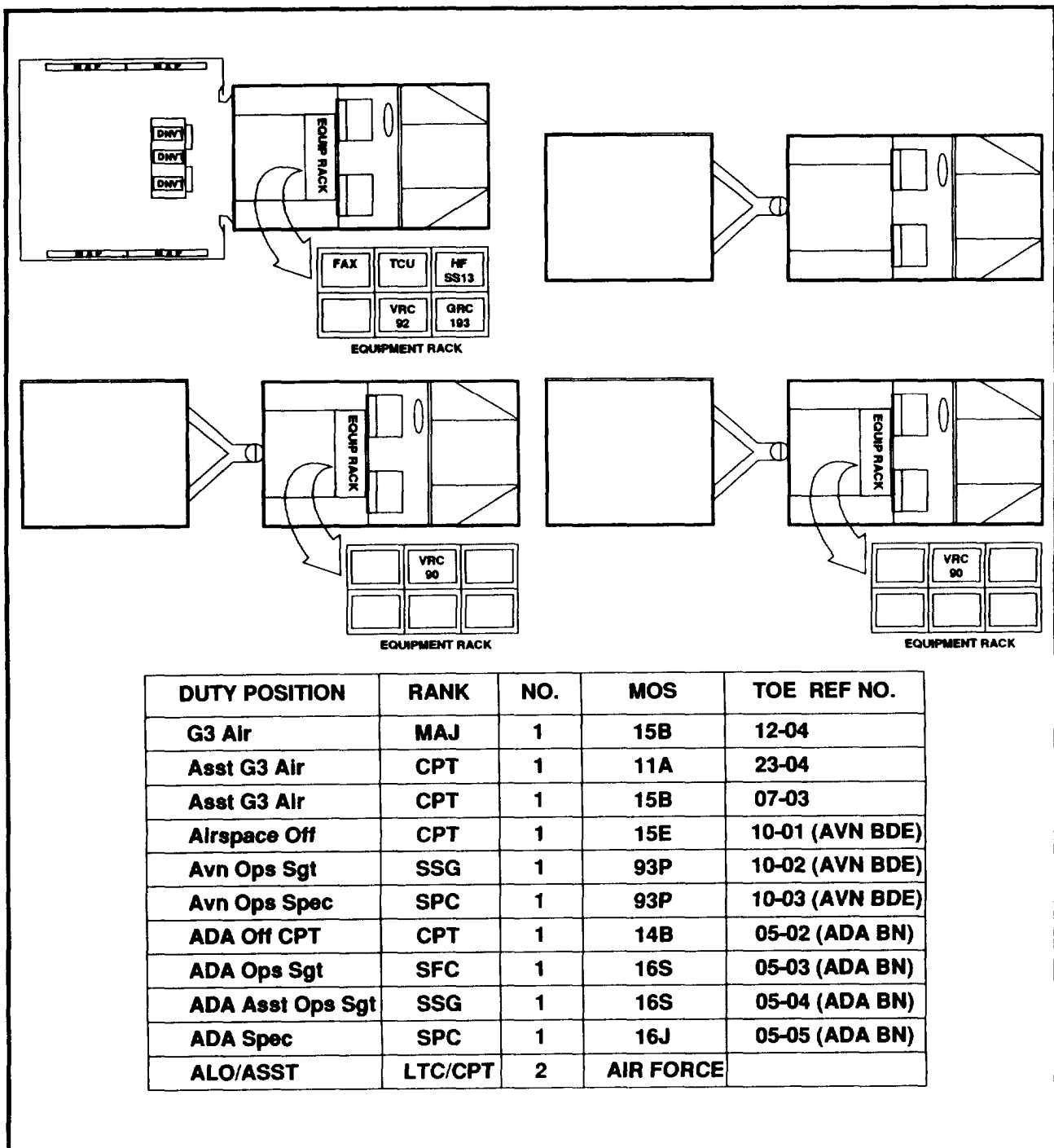

Figure 2-31. A²C² vehicle and personnel

corps for use by the division to support division aviation operations. Normally, these air corridors have a beginning altitude of 100 feet above ground level. Below this altitude, aircraft may fly

in a visual flight rules (VFR) “see and avoid” mode. They do not have to report flight operations to the corps ATC or the aviation brigade air traffic control element.

Air Defense Coordination Section. The division's organic AD battalion provides the air defense coordination section (ADCS) for the A²C² element. Its primary role is to integrate, coordinate, and synchronize all AD operations and units, both organic and supporting, in support of the division's current and future operations. It is the main CP's focus and direct link for all AD assets within the division's AO. It continuously monitors the ADA unit's dispositions and ranges of weapons systems to ensure that the division conducts tactical operations under an overlapping coverage of both divisional and corps ADA assets. The ADA section maintains communications with corps ADA units to integrate divisional ADA employment with that of the corps'.

To maintain an accurate picture of the air defense battlefield, the ADA element receives the air defense commander's situation report directly from all AD battalion-sized (and above) units supporting the operation. Air defense elements in direct support of a maneuver force report their status not only to their parent organization, but also to the supported force. This assists the supported unit in seeing its air defense battlefield. The main CP ADA element maintains the total division air defense picture by posting data on the air defense status gumball chart. (See Figure 2-32.)

The ADA cell also maintains air defense-related information on the operations map shared

with the G3 air. Information normally found on the ADA element operations map consists of—

- Probable enemy air avenues of approach and designated ADA coverage.
- Location of ADA batteries with range fans.
- Location of point targets covered by ADA elements with range fans.
- Location of corps ADA coverage supporting the division.
- Readily available overlays that show the division early warning grid.

Word chart requirements for the ADA element is kept to a minimum. The only requirements for word charts are—

- Air defense organization for combat.
- Air defense weapons control status.
- Air defense warning.

The ADA element posts graphics in conjunction with the A²C² graphics and control measures, rapidly identifying synchronization requirements that would interfere with both ground and air concepts of operation. In this way, the ADA element can react more rapidly to quickly changing A²C² requirements and coordinate them with the supporting air defense unit.

ELEMENT	Stinger	Avenger (Vulcan)	Chap	CL III	CI V	Pers		Comments
ADA Bn	<input type="checkbox"/>	<input type="checkbox"/>	<input type="checkbox"/>	<input type="checkbox"/>	<input type="checkbox"/>	<input type="checkbox"/>	<input type="checkbox"/>	
___ Btry	<input type="checkbox"/>	<input type="checkbox"/>	<input type="checkbox"/>	<input type="checkbox"/>	<input type="checkbox"/>	<input type="checkbox"/>	<input type="checkbox"/>	
___ Btry	<input type="checkbox"/>	<input type="checkbox"/>	<input type="checkbox"/>	<input type="checkbox"/>	<input type="checkbox"/>	<input type="checkbox"/>	<input type="checkbox"/>	
___ Btry	<input type="checkbox"/>	<input type="checkbox"/>	<input type="checkbox"/>	<input type="checkbox"/>	<input type="checkbox"/>	<input type="checkbox"/>	<input type="checkbox"/>	
Corps Bn	<input type="checkbox"/>	<input type="checkbox"/>	<input type="checkbox"/>	<input type="checkbox"/>	<input type="checkbox"/>	<input type="checkbox"/>	<input type="checkbox"/>	
Corps Bn	<input type="checkbox"/>	<input type="checkbox"/>	<input type="checkbox"/>	<input type="checkbox"/>	<input type="checkbox"/>	<input type="checkbox"/>	<input type="checkbox"/>	
Corps Bn	<input type="checkbox"/>	<input type="checkbox"/>	<input type="checkbox"/>	<input type="checkbox"/>	<input type="checkbox"/>	<input type="checkbox"/>	<input type="checkbox"/>	

Figure 2-32. Air defense status chart

Aviation Brigade Section. Aviation brigade representatives function within the A²C². They are assigned to the aviation brigade, but function as part of the division staff. Aviation personnel assigned A²C² staff responsibilities accomplish two tasks. First, they assist the commander in the proper employment of aviation assets, provide the necessary functional area expertise, and serve as a liaison between parent unit and the supported commander and his headquarters. Second, they assist the A²C² process by synchronizing the air-space requirements of Army aviation units with other airspace users of the combined arms team and services. The element continually provides information concerning ongoing and future aviation operations and their status to the FSE, TACP, ADA element, and G3 operations.

The aviation element is the central receiving point for aviation information concerning combat operations. It receives this information from the division's organic aviation brigade and supporting corps aviation units. The gumball chart at Figure 2-33 depicts the CCIR for aviation. Using this chart, the aviation element determines the capabilities of aviation assets. It then applies the appropriate color-coded capability to the maneuver status chart in the G3 operations cell and the command center.

The aviation element also maintains a chart that shows the current aviation organization for

combat and an operations map shared with the TACP. The aviation elements operations map should routinely maintain the following information:

- Division maneuver graphics.
- Aviation element maneuver graphics.
- Location of current and projected aviation brigade and battalion CPs.
- Location of current and projected airfields and landing zones.
- Location of current and projected forward arming and refueling points (FARPs).

Air Force Tactical Air Control Party. The Air Force provides a TACP element to the division to support all operations. The TACP advises the commander and staff on the capabilities, limitations, and employment of tactical air power. The TACP works closely with the main CP to integrate Air Force fires to support the division battle. It also controls Air Force assets, such as close air support (CAS) sorties distributed to the division. The TACP works closely with the G3 plans and current operations cells to preplan CAS sorties in advance of a current or future operation. The TACP also participates in nominating air interdiction (AI) targets. It works closely with the other elements of the A²C² cell to coordinate air space for Air Force operations.

ELEMENT	AH-64	AH-1	OH-58	OH-58D	UH-60	HELL FIRE	TOW	CLIII	PERS	COMMENTS
AVN BDE	○	○	○	○	○	○	○	○	○	
__ ATK BN	○	○	○	○	○	○	○	○	○	
__ ATK BN	○	○	○	○	○	○	○	○	○	
__ ASLT BN	○	○	○	○	○	○	○	○	○	
RECON SQDN	○	○	○	○	○	○	○	○	○	
GEN SPT AVN CO	○	○	○	○	○	○	○	○	○	
CORPS AVN ELE	○	○	○	○	○	○	○	○	○	

Figure 2-33. Aviation brigade status chart

A division air liaison officer (ALO), normally a lieutenant colonel, leads the division TACP. The ALO is supported by an assistant ALO who is the division FLO. The FLO normally works at the TAC CP or accompanies the commander in the command group. A tactical airlift liaison officer (TALO) is also a member of the TACP and normally functions at the rear command post with the G1, G4, and DTO. In addition, the ALO at the main CP has four enlisted tactical air command and control specialists, six radio maintenance personnel, two administrative personnel, two supply personnel, and two generator maintenance personnel. The division ALO also supervises the activities of brigade and battalion TACPs within the division's task organization. He reports to and coordinates Air Force support for the division with the corps ALO. Internal to the division main CP, the ALO coordinates with the G3 air for air space coordination requirements and the G3 and FSE for Air Force employment requirements.

The TACP normally supports the division main CP with four HMMWVs, each containing a GRC 206 communications pallet mounted in the rear. The AN/GRC 206 communications pallet contains HF, UHF, VHF, and FM radios, all of which are remoted from the HMMWV to the A²C² section. The TACP uses the HF radio primarily to support the Air Force air request net (AFARN) with which he talks to the corps air support operations center (ASOC) and brigade or battalion FLOs. The FM radio is a backup for the HF in support of the AFARN. The UHF and VHF radios are used primarily as ground-to-air communications. With these radios, the TACP has the organic capability to—

- Monitor how a current mission is flying.
- Monitor in-flight reports from mission pilots.
- Monitor battle damage assessments from pilots returning from missions.
- Obtain real-time intelligence from pilots.
- Coordinate any changes to airspace control measures with the mission pilots or FLO controlling the missions.

The FLO at the TAC CP works out of the FSE. The FLO element brings its own communications equipment which it remotes from its wheeled

vehicle into the FSE. With this unique Air Force communications equipment, the FLO can communicate with the ABCCC aircraft, brigade ALOs, and TACP at the main CP. The TAC CP FLO focuses primarily on responding to requests for immediate or preplanned air support for committed units. The FLO at the TAC CP works the FSE 1:50,000 scale map. Normally, he does not maintain graphic control measures on this map nor does he maintain any formal charts. He does however routinely track known bomb damage assessment (reflected on the G2 killboard), sortie availability, frequencies, weather, and rules of engagement.

The TACP works at the main command post inside the A²C² section because of the continuous operations requirement to coordinate airspace for high-performance aircraft. The TACP coordinates closely with the FSE in planning for the future employment of air resources in a fire support role. The TACP does not maintain a separate map within the A²C² section but works off the combination ADA and A²C² map. There is no information that the TACP routinely maintains on this map. He does, however, require continuous access to the control measures that are maintained not only on the ADA and A²C² map, but also on the aviation brigade and FSE maps. The TACP does not maintain charts. He does, however, maintain current information on updated and projected target lists, future sortie availability, rules of engagement, frequencies, and weather. He also actively seeks bomb damage assessment information and provides this data to the G2 for updating the enemy killboard.

Fire Support Element

The main CP FSE is the division's focal point for planning, coordinating, and integrating all fire support for division operations. The FSE functions out of a HMMWV and SICP tent which is organic to the DIVARTY. In addition to the DIVARTY personnel, the assistant division engineer (ADE) element and the division electronic warfare element normally work in the FSE (Figure 2-34). The functions of the FSE include—

- Synchronizing all organic and supporting lethal and nonlethal fire support for division deep, close, and rear operations.

DUTY POSITION	RANK	NO.	MOS	TOE REF NO.
Deputy FSCoord	LTC	1	13A	05-01 (DIVARTY)
Asst FSCoord	MAJ	2	13A	
Target Analyst	CPT	2	13A	
FS Ops Sgt	MSG	1	13Z	05-06 (DIVARTY)
FS Ops Sgt	SFC	1	13Z	
FS Ops Sgt	SGT	1	13Z	
Clerk Typist	SPC	1	71L	
SIG/EW Off	MAJ	1	35G	
SIG/EW Off	CPT	1	35G	17-04
SIG/EW NCO	SFC	1	98C	
SIG/EW Analyst	SGT	1	98C	17-05
Asst Div EN	MAJ	1	21B	01-04
Chief EN NCO	MSG	1	12Z	09-02 (EN BN)
Construction NCO	SFC	1	12B	
Tech Drafting Spec	SPC	1	81B	09-04 (EN BN)

Figure 2-34. Fire support element vehicle and personnel

- Establishing priorities and allocating available fire support resources to support the division battle.

- Planning and controlling all deep fires in support of division deep operations.

- Providing field artillery intelligence officers to the all source production section (ASPS) to facilitate the division targeting process.

- Responding to requests for additional fire support from the TAC CP FSE, rear CP, or other subordinate FSEs.

- Participating in and supervising the routine activity and coordination of the targeting process within the division main CP.

- Coordinating with the A2C2 element regarding current artillery firing unit locations, changes to fire support coordination measures, and significant fires which may impact airspace users.

The main CP FSE continuously interacts with other elements in the G2 and G3 operations cells to plan, coordinate, and integrate fire support for current and future operations. Additionally, the main CP FSE provides the command cell with current decision information as required. The division main CP FSE may also receive artillery LOS or representatives from other fire support means.

DIVARTY Section. The DIVARTY section in the FSE works for and responds directly to the division G3 in support of the division's battle. It is responsible for all FSE functions and exercises overall coordination responsibilities of other sections within the fire support cell. The FSE is responsible to the G3 for allocating FA resources and FA priorities in support of deep, close, and rear operations. Fire support elements located at the TAC and rear CPs are an extension of the main CP FSE. They assist the main FSE in controlling those assets' functioning within the close and rear areas of operations.

The main CP FSE functions similar to the TAC CP FSE, although its scope is much broader. The main CP DIVARTY section maintains a 1:50,000 fire support operations map that is standard throughout the CP. It does not maintain duplicate maps for the G3 operations or the command center. Information on the main CP fire support operations map includes—

- Division's and corps' maneuver graphics and control measures.
- Locations of all organic and supporting FA battalions and MLRS batteries with range fans.
- Division's and corps' fire control measures and graphics.
- Location of nonlethal EW assets supporting the division.

- Location of adjacent, forward, and rearward fire support assets capable of supporting the division.
- Known locations of the enemy's FA battalions.

This information is routinely overlaid on the G3 operations map and the command center map to maintain a central perspective on the location of fire support assets in relation to maneuver units. From this detailed overlay, the FSE updates the command center map with changes to fire control measures. The main CP's FSE normally maintains the fire support organization for combat chart and the high-payoff target list and priorities.

The main CP FSE also maintains a FA status chart (Figure 2-35). However, the main CP FSE tracks all field artillery units supporting the division, not just those supporting close or rear operations. This chart becomes the basis for the fire support capability, both current and projected, that the division uses to support current, and plan future, operations. The FSE posts and analyzes information received from the DIVARTY and supporting corps FA brigade headquarters in the artillery commander's situation report. Changes in combat capability as pertains to FA units is quickly posted on the FA status chart and task organization chart located in the command center. The FSEs at the TAC and rear CPS also support the status charts as information becomes available to them. Normally, reports from the TAC and rear CPS either update information already on hand or support information provided by the DIVARTY.

Engineer Section. The engineer section that functions next to the FSE is organic to the division's engineer battalion and is led by the ADE. It recommends to the division commander engineer

work and support priorities and allocates engineer resources to support the division battle. It is a direct link to the division's organic engineer battalion and other corps engineer battalions to support current, and plan future, operations. In this CP design, the engineer section is located in the fire support cell. There, it ensures that throughout the division AO, obstacles are synchronized and covered with fires. Additionally, it coordinates fire support for breaching operations and scatterable mines.

To maintain an accurate picture of the battlefield for engineers, the engineer element receives a commander's situation report directly from organic and supporting engineer headquarters. Engineer units in direct support to a maneuver force report their status not only to their parent unit but also to the supported force to assist them in seeing the battlefield. The main CP engineer element posts information requirements on the engineer status gumball chart (Figure 2-36, page 2-50). The status of brigade and separate battalion obstacle belts on enemy avenues of approach is maintained with the gumball chart shown at Figure 2-37, page 2-50. This chart uses the same green, amber, red, black percentages as all other gumball charts. Here, the colors also depict the capability and degree of completion of obstacle belts.

In addition to maintaining the unit and obstacle status gumball charts, the engineers also maintain specific data on their operations map and charts. The only word chart the engineer section requires is the task organization chart. Critical information normally found on the engineer operations map includes—

- Location of engineer battalion or brigade CP.

ELEMENT	105/155 mm	8"	MLRS	Tgt Radar	TAC FIRE	CL IN	CL V		COMMENTS
DIVARTY	○	○	○	○	○	○	○	○	
Corps Arty	○	○	○	○	○	○	○	○	
Corps Arty	○	○	○	○	○	○	○	○	
	○	○	○	○	○	○	○	○	

Figure 2-35. Field artillery status chart

ELEMENT	SEE	ACE	Bridge		CL III	CL IV	CL V	Pers		Comments
Engr Bn	<input type="checkbox"/>	<input type="checkbox"/>	<input type="checkbox"/>	<input type="checkbox"/>	<input type="checkbox"/>	<input type="checkbox"/>	<input type="checkbox"/>	<input type="checkbox"/>		
____ Co	<input type="checkbox"/>	<input type="checkbox"/>	<input type="checkbox"/>	<input type="checkbox"/>	<input type="checkbox"/>	<input type="checkbox"/>	<input type="checkbox"/>	<input type="checkbox"/>		
____ Co	<input type="checkbox"/>	<input type="checkbox"/>	<input type="checkbox"/>	<input type="checkbox"/>	<input type="checkbox"/>	<input type="checkbox"/>	<input type="checkbox"/>	<input type="checkbox"/>		
____ Co	<input type="checkbox"/>	<input type="checkbox"/>	<input type="checkbox"/>	<input type="checkbox"/>	<input type="checkbox"/>	<input type="checkbox"/>	<input type="checkbox"/>	<input type="checkbox"/>		
____ Co	<input type="checkbox"/>	<input type="checkbox"/>	<input type="checkbox"/>	<input type="checkbox"/>	<input type="checkbox"/>	<input type="checkbox"/>	<input type="checkbox"/>	<input type="checkbox"/>		
	<input type="checkbox"/>	<input type="checkbox"/>	<input type="checkbox"/>	<input type="checkbox"/>	<input type="checkbox"/>	<input type="checkbox"/>	<input type="checkbox"/>	<input type="checkbox"/>		
Corps Engr Bn	<input type="checkbox"/>	<input type="checkbox"/>	<input type="checkbox"/>	<input type="checkbox"/>	<input type="checkbox"/>	<input type="checkbox"/>	<input type="checkbox"/>	<input type="checkbox"/>		
Corps Engr Bn	<input type="checkbox"/>	<input type="checkbox"/>	<input type="checkbox"/>	<input type="checkbox"/>	<input type="checkbox"/>	<input type="checkbox"/>	<input type="checkbox"/>	<input type="checkbox"/>		
Corps Engr Bn	<input type="checkbox"/>	<input type="checkbox"/>	<input type="checkbox"/>	<input type="checkbox"/>	<input type="checkbox"/>	<input type="checkbox"/>	<input type="checkbox"/>	<input type="checkbox"/>		
Bridge Co	<input type="checkbox"/>	<input type="checkbox"/>	<input type="checkbox"/>	<input type="checkbox"/>	<input type="checkbox"/>	<input type="checkbox"/>	<input type="checkbox"/>	<input type="checkbox"/>		

Figure 2-36. Engineer status chart

ELEMENT	Zone/ Be/AA _____	Zone/ Be/AA _____	Zone/ Be/AA _____	Zone/ Be/AA _____	Comments
1st Bde	Pri: <input type="checkbox"/> Intent: <input type="checkbox"/>	Pri: <input type="checkbox"/> Intent: <input type="checkbox"/>	Pri: <input type="checkbox"/> Intent: <input type="checkbox"/>	Pri: <input type="checkbox"/> Intent: <input type="checkbox"/>	<input type="checkbox"/>
2d Bde	Pri: <input type="checkbox"/> Intent: <input type="checkbox"/>	Pri: <input type="checkbox"/> Intent: <input type="checkbox"/>	Pri: <input type="checkbox"/> Intent: <input type="checkbox"/>	<input type="checkbox"/>	<input type="checkbox"/>
3rd Bde	Pri: <input type="checkbox"/> Intent: <input type="checkbox"/>	Pri: <input type="checkbox"/> Intent: <input type="checkbox"/>	<input type="checkbox"/>	<input type="checkbox"/>	<input type="checkbox"/>
Avn Bde	<input type="checkbox"/>	<input type="checkbox"/>	<input type="checkbox"/>	<input type="checkbox"/>	<input type="checkbox"/>
Other	<input type="checkbox"/>	<input type="checkbox"/>	<input type="checkbox"/>	<input type="checkbox"/>	<input type="checkbox"/>

Figure 2-37. Engineer belt and obstacle status chart

- Location of bridging assets (not including armored vehicle launched bridges (AVLBs)).
- Maneuver graphic control measures.
- Division and corps-directed obstacle free zones and belts.
- Division-directed obstacle zones.
- Brigade and separate battalion obstacle belts.
- Location and status of division- and corps-directed obstacles.
- Location of division and corps reserve targets.

- Current priorities of effort and support in the division sector.

The engineer section at the main CP cannot—and must not—try to track each individual obstacle in the division's AO unless those obstacles are part of the CCIR. Obstacle zones and belts, with their completion status, are enough to see the engineer battlefield. Information on the status of an obstacle may be obtained from the engineer headquarters that emplaced it or the maneuver headquarters that directed it.

Electronic Warfare Section. The EW section is located in the FSE. It is organic to the

division's G3 cell. Under the deputy fire support coordinator (FSCoord), the EW section plans, coordinates, and monitors nonlethal EW operations in coordination with the FSE, A²C², G2 and G3 current operations, and plans elements. The EW section works closely with the ADSO to implement electronic counter-countermeasures (ECCM) and manipulative electronic deception. With the G2 and military intelligence (MI) battalion technical control and analysis element (TCAE), the EW section continually evaluates the vulnerability of enemy emitters to electronic countermeasures (ECM). It advises the G2, G3, and DFSCoord on recommended courses of action. It recommends enemy targets vulnerable to effective ECM to support current and planned operations; it also tasks the appropriate supporting EW unit. Additionally, the EW section

recommends to the G3 priorities for jamming by direct support (DS) and general support (GS) assets for current or future battles. The EW section integrates, coordinates, and synchronizes all E W assets in support of the division battle.

Assistant Division Signal Officer Element

The ADSO element is located at the main CP adjacent to the G3 plans. The ADSO's personnel and equipment are organic to the division's signal battalion. The ADSO element performs its functions from a HMMWV (Figure 2-38). While supporting the main CP, the ADSO—

- Coordinates, integrates, and synchronizes all organic and supporting communications assets (including satellite communications) to support the division battle.

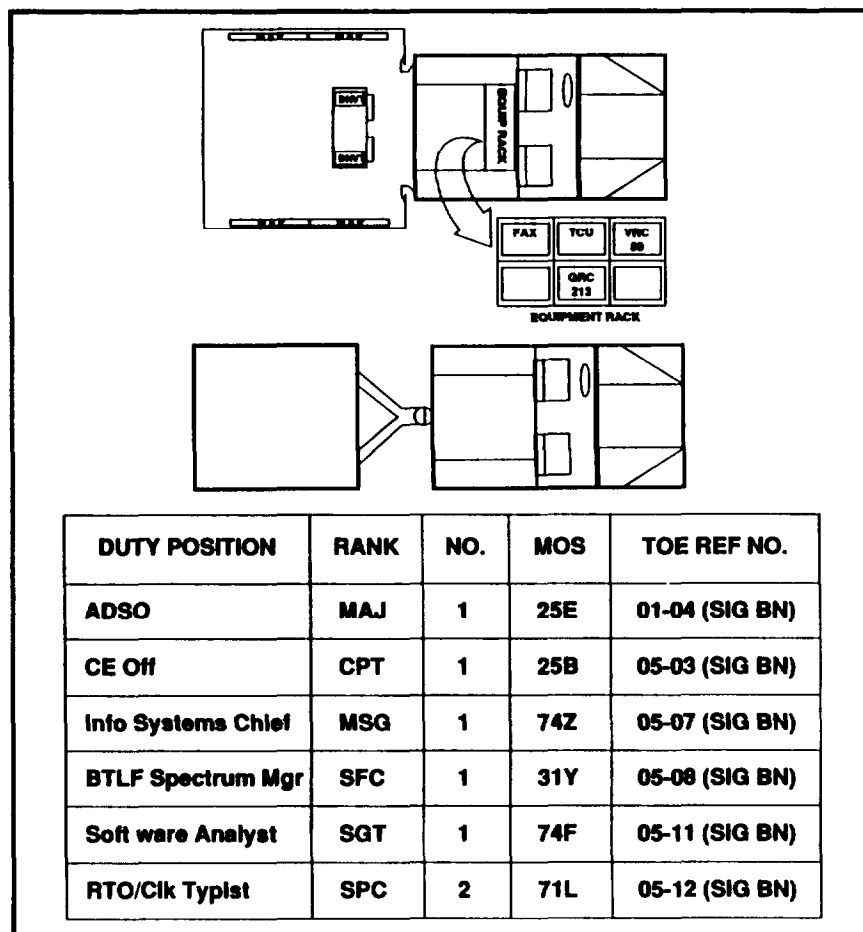

Figure 2-38. ADSO vehicle and personnel

- Allocates resources and establishes priorities for deep, close, and rear operations.

- Anticipates and plans for the employment and positioning of communication assets for future operations.

The ADSO works for and reports to the G3. Its most critical role is to serve as the primary staff coordination element between the main CP and the signal battalion and other supporting signal elements. Therefore, the ADSO continuously monitors current deep, close, and rear operations, recommends changes to signal support, and keeps the supporting signal elements advised of immediate and future changes. The ADSO element does not install or fix telephones or radio equipment. If necessary, the signal battalion will perform these tasks. The ADSO manages the signal support provided the TAC, main, and rear CPS in support of the division battle. It synchronizes all aspects of signal operations in support of deception and EW operations.

Organic and supporting signal units provide their status to the ADSO cell. The gumball chart at Figure 2-39 provides those CCIR from a communications perspective. The ADSO also maintains a word chart and an operations map that contain other critical information not suitable for gumball display. The only word chart required by the ADSO depicts the signal element organization for combat. Common signal information normally found on the ADSO's operations map is as follows:

- Maneuver graphic control measures.
- Location of organic and supporting battalion and company CPS.
- Location of key signal-supported CP facilities.

- Current and projected node center locations.

Nuclear, Biological Chemical Element

The NBC element performs its functions from a HMMWV and SICPS tent (Figure 2-40). When functioning in support of the main CP, the NBC element works for and reports to the G3. The NBC element—

- Allocates resources, and establishes priorities for NBC in support of the division's deep, close, and rear operations.

- Operates the division NBC warning and reporting system.

The division's chemical officer oversees all NBC elements within the main CP. He is the catalyst who must position himself where he can best influence the division's chemical battle and synchronize it with all BOS. He is the advisor to the division commander and G3 on all NBC-related matters. He supervises the overall NBC function. The division chemical officer works out of the NBC section in the main CP. He coordinates, synchronizes, integrates, and plans NBC operations to support current and future operations. He recommends how to allocate resources and plan priorities of work for chemical units assigned, attached, or OPCON to the division. The NBC section is the focal point for all NBC-related operations at the main CP and within the division.

As the hub of NBC operations for the division, the NBC element prepares NBC estimates, and monitors equipment status and the host nation's NBC support requirements. It coordinates the use of deliberate smoke for current and future tactical operations. It also disseminates contamination overlays and NBC reports to all units.

ELEMENT	MSE	TACSAT	HF	FM	MCS	FAX			Comments
Div Sig Bn	○	○	○	○	○	○	○	○	
Corps Sig Elm	○	○	○	○	○	○	○	○	
Corps Sig Elm	○	○	○	○	○	○	○	○	
Corps Sig Elm	○	○	○	○	○	○	○	○	

Figure 2-39. Signal equipment status chart

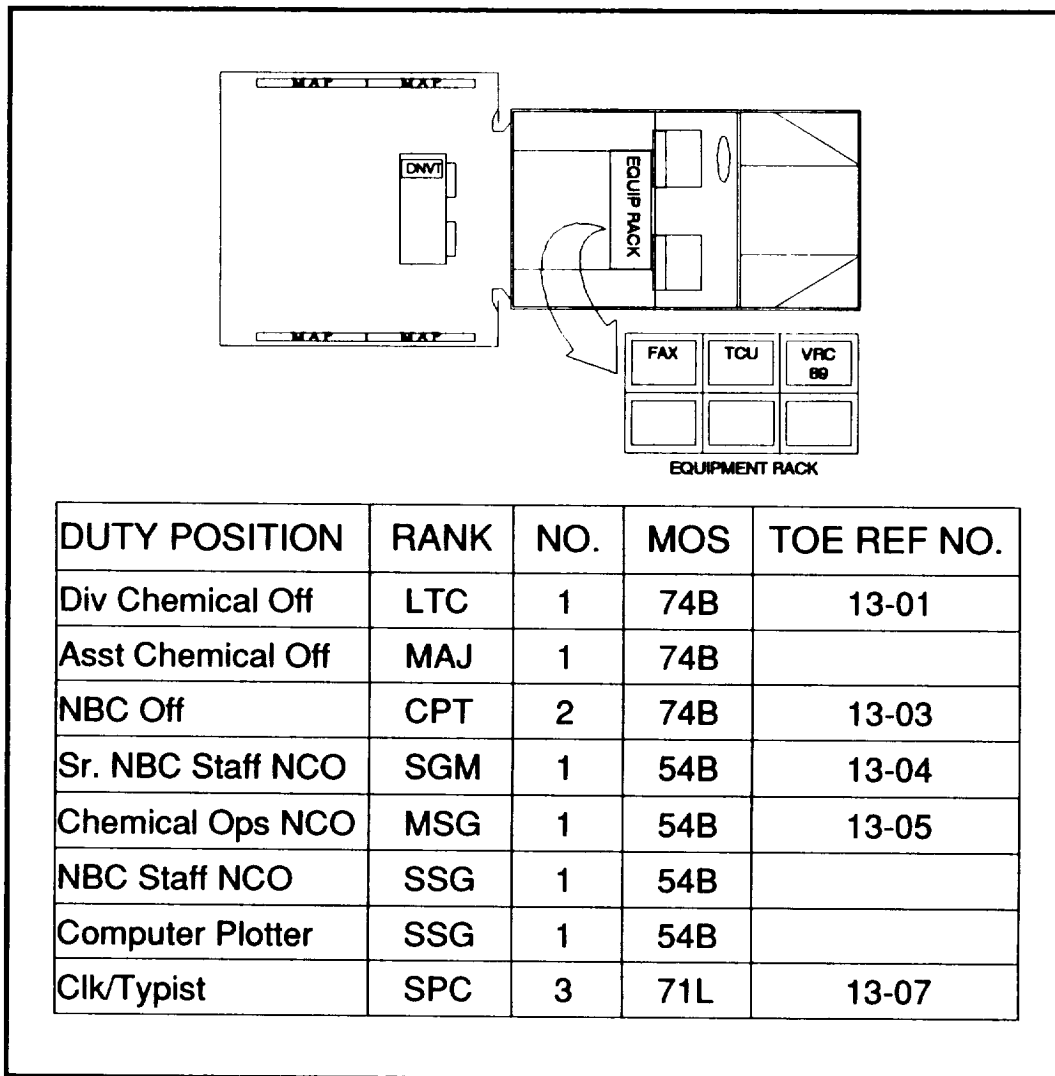

Figure 2.40. NBC vehicle and personnel

From an NBC perspective, the chemical platoon provides the commander's critical information both to the supported units, if it is in direct support of them, and to the parent chemical company. The NBC element maintains a status of all chemical elements capability. This comes from commanders' situation reports and from the organic chemical company and any supporting chemical element. Gumball charts at Figures 2-41 and 2-42, page 2-54, depict the commander's critical NBC information requirements. The NBC element also maintains a picture of NBC equipment survivability. It depicts this status through spot reports from MSC chemical

personnel and close coordination with the G4 at the rear CP. This status is maintained by the division chemical section to NBC logistics.

Additionally, the NBC element maintains an NBC operations map. Information normally on the NBC operations map is as follows:

- Maneuver graphic control measures.
- Current and projected decontamination sites.
- Location of organic and supporting chemical units.
- Location of chemical attacks and contaminated areas.

ELEMENT	PDDE-H	PDDE-L	Smoke Gen	Recon Vehicle	CL III Fogoil	Pers	Comments
NBC Co	<input type="checkbox"/>	<input type="checkbox"/>	<input type="checkbox"/>	<input type="checkbox"/>	<input type="checkbox"/>	<input type="checkbox"/>	
Recon Plt	<input type="checkbox"/>	<input type="checkbox"/>	<input type="checkbox"/>	<input type="checkbox"/>	<input type="checkbox"/>	<input type="checkbox"/>	
Smoke Plt	<input type="checkbox"/>	<input type="checkbox"/>	<input type="checkbox"/>	<input type="checkbox"/>	<input type="checkbox"/>	<input type="checkbox"/>	
___ Decon Plt	<input type="checkbox"/>	<input type="checkbox"/>	<input type="checkbox"/>	<input type="checkbox"/>	<input type="checkbox"/>	<input type="checkbox"/>	
___ Decon Plt	<input type="checkbox"/>	<input type="checkbox"/>	<input type="checkbox"/>	<input type="checkbox"/>	<input type="checkbox"/>	<input type="checkbox"/>	
___ Decon Plt	<input type="checkbox"/>	<input type="checkbox"/>	<input type="checkbox"/>	<input type="checkbox"/>	<input type="checkbox"/>	<input type="checkbox"/>	
___ Decon Plt	<input type="checkbox"/>	<input type="checkbox"/>	<input type="checkbox"/>	<input type="checkbox"/>	<input type="checkbox"/>	<input type="checkbox"/>	
Corps Chem Elm	<input type="checkbox"/>	<input type="checkbox"/>	<input type="checkbox"/>	<input type="checkbox"/>	<input type="checkbox"/>	<input type="checkbox"/>	
Corps Chem Elm	<input type="checkbox"/>	<input type="checkbox"/>	<input type="checkbox"/>	<input type="checkbox"/>	<input type="checkbox"/>	<input type="checkbox"/>	
Corps Chem Elm	<input type="checkbox"/>	<input type="checkbox"/>	<input type="checkbox"/>	<input type="checkbox"/>	<input type="checkbox"/>	<input type="checkbox"/>	

Figure 2-41. NBC status chart

ELEMENT	Mask	Filters	BDO	Gloves	Boots	NAAK	258 KIT	M8 Alarm	256 Kit	M11/M13	Comments
1st Bde	<input type="checkbox"/>	<input type="checkbox"/>	<input type="checkbox"/>	<input type="checkbox"/>	<input type="checkbox"/>	<input type="checkbox"/>	<input type="checkbox"/>	<input type="checkbox"/>	<input type="checkbox"/>	<input type="checkbox"/>	
2d Bde	<input type="checkbox"/>	<input type="checkbox"/>	<input type="checkbox"/>	<input type="checkbox"/>	<input type="checkbox"/>	<input type="checkbox"/>	<input type="checkbox"/>	<input type="checkbox"/>	<input type="checkbox"/>	<input type="checkbox"/>	
3rd Bde	<input type="checkbox"/>	<input type="checkbox"/>	<input type="checkbox"/>	<input type="checkbox"/>	<input type="checkbox"/>	<input type="checkbox"/>	<input type="checkbox"/>	<input type="checkbox"/>	<input type="checkbox"/>	<input type="checkbox"/>	
Avn Bde	<input type="checkbox"/>	<input type="checkbox"/>	<input type="checkbox"/>	<input type="checkbox"/>	<input type="checkbox"/>	<input type="checkbox"/>	<input type="checkbox"/>	<input type="checkbox"/>	<input type="checkbox"/>	<input type="checkbox"/>	
Cav Sqdn	<input type="checkbox"/>	<input type="checkbox"/>	<input type="checkbox"/>	<input type="checkbox"/>	<input type="checkbox"/>	<input type="checkbox"/>	<input type="checkbox"/>	<input type="checkbox"/>	<input type="checkbox"/>	<input type="checkbox"/>	
DIVARTY	<input type="checkbox"/>	<input type="checkbox"/>	<input type="checkbox"/>	<input type="checkbox"/>	<input type="checkbox"/>	<input type="checkbox"/>	<input type="checkbox"/>	<input type="checkbox"/>	<input type="checkbox"/>	<input type="checkbox"/>	
DISCOM	<input type="checkbox"/>	<input type="checkbox"/>	<input type="checkbox"/>	<input type="checkbox"/>	<input type="checkbox"/>	<input type="checkbox"/>	<input type="checkbox"/>	<input type="checkbox"/>	<input type="checkbox"/>	<input type="checkbox"/>	
Engr Bn	<input type="checkbox"/>	<input type="checkbox"/>	<input type="checkbox"/>	<input type="checkbox"/>	<input type="checkbox"/>	<input type="checkbox"/>	<input type="checkbox"/>	<input type="checkbox"/>	<input type="checkbox"/>	<input type="checkbox"/>	
ADA Bn	<input type="checkbox"/>	<input type="checkbox"/>	<input type="checkbox"/>	<input type="checkbox"/>	<input type="checkbox"/>	<input type="checkbox"/>	<input type="checkbox"/>	<input type="checkbox"/>	<input type="checkbox"/>	<input type="checkbox"/>	
MI Bn	<input type="checkbox"/>	<input type="checkbox"/>	<input type="checkbox"/>	<input type="checkbox"/>	<input type="checkbox"/>	<input type="checkbox"/>	<input type="checkbox"/>	<input type="checkbox"/>	<input type="checkbox"/>	<input type="checkbox"/>	
Signal Bn	<input type="checkbox"/>	<input type="checkbox"/>	<input type="checkbox"/>	<input type="checkbox"/>	<input type="checkbox"/>	<input type="checkbox"/>	<input type="checkbox"/>	<input type="checkbox"/>	<input type="checkbox"/>	<input type="checkbox"/>	
MP Co	<input type="checkbox"/>	<input type="checkbox"/>	<input type="checkbox"/>	<input type="checkbox"/>	<input type="checkbox"/>	<input type="checkbox"/>	<input type="checkbox"/>	<input type="checkbox"/>	<input type="checkbox"/>	<input type="checkbox"/>	
TAC CP	<input type="checkbox"/>	<input type="checkbox"/>	<input type="checkbox"/>	<input type="checkbox"/>	<input type="checkbox"/>	<input type="checkbox"/>	<input type="checkbox"/>	<input type="checkbox"/>	<input type="checkbox"/>	<input type="checkbox"/>	
MAIN CP	<input type="checkbox"/>	<input type="checkbox"/>	<input type="checkbox"/>	<input type="checkbox"/>	<input type="checkbox"/>	<input type="checkbox"/>	<input type="checkbox"/>	<input type="checkbox"/>	<input type="checkbox"/>	<input type="checkbox"/>	
REAR CP	<input type="checkbox"/>	<input type="checkbox"/>	<input type="checkbox"/>	<input type="checkbox"/>	<input type="checkbox"/>	<input type="checkbox"/>	<input type="checkbox"/>	<input type="checkbox"/>	<input type="checkbox"/>	<input type="checkbox"/>	

Figure 2-42. NBC survivability equipment status chart

- Location and range fans of enemy units capable of firing chemical munitions.

- Overlay for preplanned smoke operations.

Word charts also contribute to the NBC element's capability to see the NBC battlefield. The NBC element normally requires word charts that display—

- Chemical units' organization for combat.

- Division-directed mission-oriented protective posture (MOPP) status.

- The MSC MOPP status, if it is different from the divisions.

G2 Cell

The G2 cell, located at the main CP, requests, collects, analyzes, produces, and distributes weather and combat intelligence, and

time-sensitive information about the enemy for the division's deep, close, and rear current and future operations. It comprises a G2 operations element, an ASPS, an Air Force weather team, and a division terrain team. The functions of the G2 cell are to—

- Provide intelligence to the commander and staff in support of the division battle.
- Coordinate, integrate, and synchronize intelligence, counterintelligence, all source production, SS0, weather, and engineer topographic operations.
- Coordinate with the division's staff to ensure intelligence operations support maneuver and targeting.
- Coordinate and direct tactical reconnaissance and surveillance operations.

The G2 and his staff are the commander's experts on the enemy and provide critical intelligence for divisional operations. They analyze the data being presented concerning the enemy force and translate it to the commander in terms understandable by US doctrinal concepts. The G2 is responsible for the overall intelligence effort for the division's battle, both current and future, and the analysis of terrain, weather, and the enemy situation. He must predict the tactical intentions of the enemy force confronting the division and identify the enemy's strengths and weaknesses. From the commander's guidance and concept of the operation, the G2 develops and implements the division's PIR and intelligence requirements (IR) and translates them into taskings or requests for intelligence. He ensures collection priorities are synchronized with and support the concept of operation. *He is a critical element in the development of targeting guidance.* Under the G2's supervision, corps and tactical intelligence is fused into an integrated all-source product that is rapidly disseminated. The G2 has, and exercises, primary staff responsibility for planning, coordinating, and executing electronic support measures (ESM) operations throughout the division's AO.

The division's intelligence system is linked to the theater, corps, and allied intelligence systems. It relies heavily on a combination of sophisticated collection assets for support. SLAR, Guardrail, Quicklook, and EAC intelligence

assets feed the intelligence system near real-time intelligence to support the division's deep, close, and rear operations. HUMINT, IMINT, and SIGINT assets available to the division provide surveillance and reconnaissance information. Information is also obtained by requesting it through the corps,

The G2 cell sends out requests and taskings to higher and lower echelons. SIGINT and EW assets report information back to the MI battalion TCAE where the collected information is analyzed, correlated, and transmitted as intelligence to the ASPS.

The G2 cell monitors reporting and completion of assigned tasks and further disseminates intelligence and information to appropriate commands, agencies, or staffs. Military intelligence assets such as interrogation, counterintelligence (CI), and aerial surveillance personnel send information directly to the ASPS for analysis and integration into the all-source data base.

G2 Operations Element

The G2 operations element is located at the main CP (Figure 2-43). The G2 operations is the hub of intelligence operations within the division. Both the TAC CP and rear CP have G2 elements that support the G2 operations at the main CP, focusing on close and rear operations respectively. The G2 operations directs collection, management, and dissemination of intelligence. It translates intelligence requirements into collection missions for intelligence assets supporting the division. It receives, analyzes, consolidates, and assigns priorities to intelligence and electronic warfare (IEW) requirements generated by current and future tactical operations. It must disseminate combat information and intelligence to the right user at the right time. The G2 operations coordinates and directs tactical reconnaissance, counter-reconnaissance, and surveillance operations.

The G2 and G3 operations elements work closely with the command center to maintain an enemy "picture of the battlefield," to support the development of branches to current operations and future planning. The G2 operations element coordinates daily G2 operations requirements with other elements and sections of the main CP

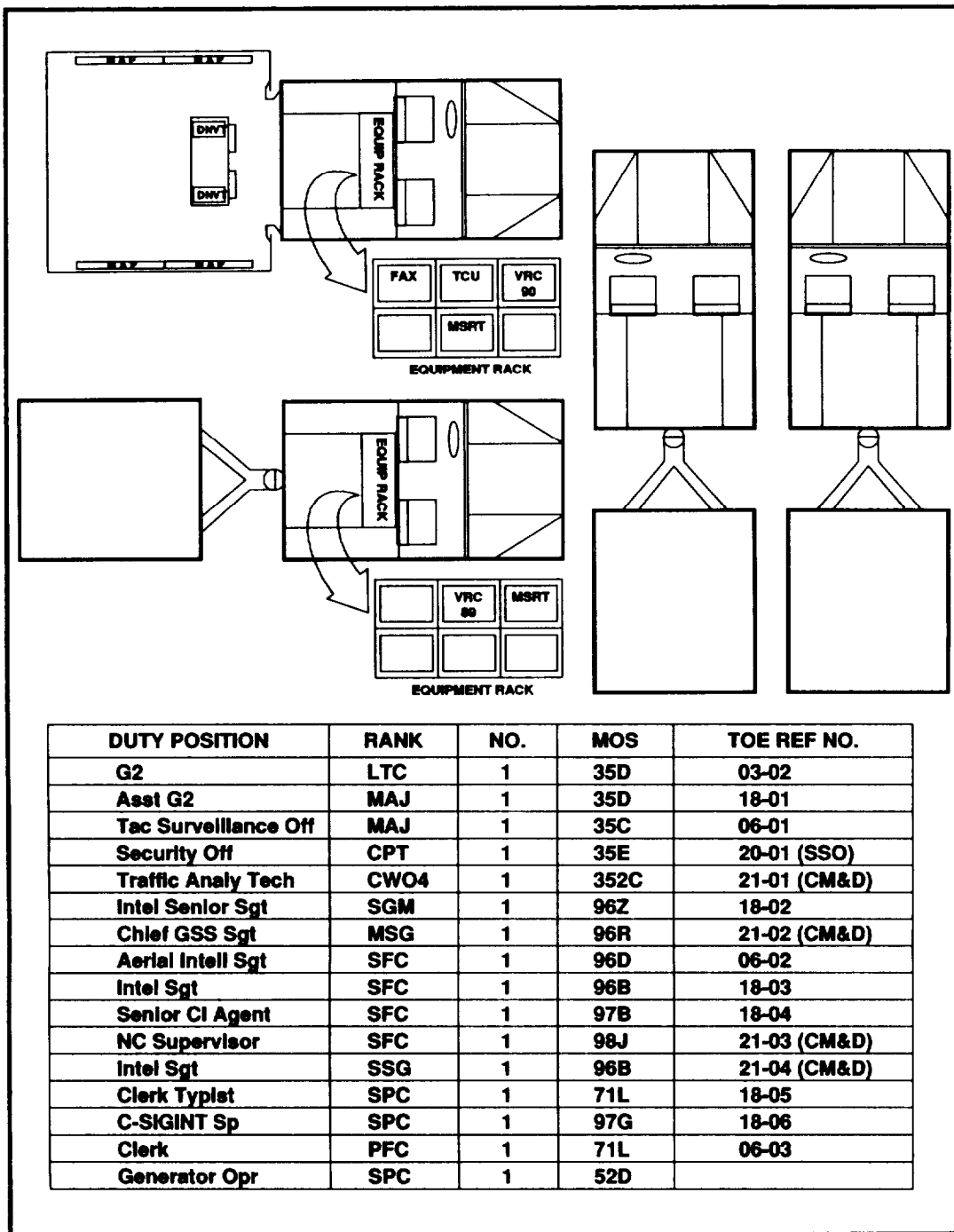

Figure 2.43. G2 operations cell vehicle and personnel

and elements of the TAC and rear CPs. In close coordination with G3 operations, the G2 operations integrates and coordinates intelligence requirements. It continuously converts elements of enemy information into analyzed combat

intelligence, providing it to the G3 operations cell and command center. Additionally, the G2 operations element shares this intelligence with all other elements of the main and other CPs as appropriate.

Sharing of intelligence aids in developing knowledge of the enemy's current situation and projecting his future intentions. Through continuous intelligence preparation of the battlefield (IPB) and intelligence collection planning, the G2 operations gathers information to detect and track the enemy's critical HPTs. It provides this time-sensitive information to the fire support cell for immediate engagement by lethal or nonlethal fires. It tasks the MI battalion as the principal agency for this information. It tasks all divisional and supporting elements with collection missions within their capabilities. The G2 operations plans, directs, and coordinates counterintelligence operations throughout the division's AO. It coordinates with corps counterintelligence elements and various division elements to satisfy support requirements. It also works closely with the G3 operations to develop OPSEC to protect friendly essential elements of friendly information (EEFI).

The G2 at the main CP maintains two separate maps. Routine intelligence operations supporting the current operation are normally on a 1:50,000 scale map. This map is standardized with all other maps in the CP. It depicts the enemy and intelligence situation within the division's AO. A 1:250,000 scale or larger (depending on the theater of operations) depicts the division's area of interest and facilitates future planning. The G2 operations map should routinely display the following intelligence information:

- Current and projected locations of enemy units one level up and two levels down.

- Friendly force maneuver graphics and control measures.

- NAIs, TAIs, and other intelligence-oriented decision graphics.

- Location of critical intelligence collection assets with orientation or range fans.

- Enemy threat to flanking units.

- Projected enemy course of action graphics.

From this central bank of intelligence information, G2 operations personnel extract trends, confirm or deny the enemy's intentions, project the enemy's future intentions, and transfer selected or analyzed information onto the command center operations map. The G2 operations map and the command center map, however, do not duplicate each other.

Word charts required by the G2 operations cell are kept to an absolute minimum. Normally, it requires only two charts—one showing the task organization of MI battalion and supporting corps intelligence assets, and the other, the PIRs, Weather and light data charts and an enemy kill board similar to Figure 2-17 are other potentially useful charts.

The intelligence status board depicts the status of critical items supporting the intelligence collection effort. (See Figure 2-44.) This board tracks key equipment of the MI battalion and corps supporting units. The command center has a similar board that depicts a summary of this board for battalion or larger elements.

ELEMENT	TEAM MATE	TRAIL-BLZR	TEAM-PACK	GSR	TRAFFIC JAM	QUICK FIX	CL IN	CL V	Pers	Comments
MI Bn	<input type="checkbox"/>	<input type="checkbox"/>	<input type="checkbox"/>	<input type="checkbox"/>	<input type="checkbox"/>	<input type="checkbox"/>	<input type="checkbox"/>	<input type="checkbox"/>	<input type="checkbox"/>	
HQ & SVC Co	<input type="checkbox"/>	<input type="checkbox"/>	<input type="checkbox"/>	<input type="checkbox"/>	<input type="checkbox"/>	<input type="checkbox"/>	<input type="checkbox"/>	<input type="checkbox"/>	<input type="checkbox"/>	
COLL Co	<input type="checkbox"/>	<input type="checkbox"/>	<input type="checkbox"/>	<input type="checkbox"/>	<input type="checkbox"/>	<input type="checkbox"/>	<input type="checkbox"/>	<input type="checkbox"/>	<input type="checkbox"/>	
INTEL/SURVL Co	<input type="checkbox"/>	<input type="checkbox"/>	<input type="checkbox"/>	<input type="checkbox"/>	<input type="checkbox"/>	<input type="checkbox"/>	<input type="checkbox"/>	<input type="checkbox"/>	<input type="checkbox"/>	
LRS	<input type="checkbox"/>	<input type="checkbox"/>	<input type="checkbox"/>	<input type="checkbox"/>	<input type="checkbox"/>	<input type="checkbox"/>	<input type="checkbox"/>	<input type="checkbox"/>	<input type="checkbox"/>	
Corps MI Elm	<input type="checkbox"/>	<input type="checkbox"/>	<input type="checkbox"/>	<input type="checkbox"/>	<input type="checkbox"/>	<input type="checkbox"/>	<input type="checkbox"/>	<input type="checkbox"/>	<input type="checkbox"/>	
T/E Elm	<input type="checkbox"/>	<input type="checkbox"/>	<input type="checkbox"/>	<input type="checkbox"/>	<input type="checkbox"/>	<input type="checkbox"/>	<input type="checkbox"/>	<input type="checkbox"/>	<input type="checkbox"/>	
IPW Elm	<input type="checkbox"/>	<input type="checkbox"/>	<input type="checkbox"/>	<input type="checkbox"/>	<input type="checkbox"/>	<input type="checkbox"/>	<input type="checkbox"/>	<input type="checkbox"/>	<input type="checkbox"/>	
CI Elm	<input type="checkbox"/>	<input type="checkbox"/>	<input type="checkbox"/>	<input type="checkbox"/>	<input type="checkbox"/>	<input type="checkbox"/>	<input type="checkbox"/>	<input type="checkbox"/>	<input type="checkbox"/>	

Figure 2-44. G2 operations intelligence collection asset status board

AU Source Production Section

The ASPS works for, and is supervised by, the division G2. The section performs its functions within a HMMWV and SICPS tent, located adjacent to the G2 operations element. It contains 21 personnel to support continuous operations (Figure 2-45). The ASPS is responsible to the G2. Specifically, it develops and maintains the division's intelligence data base and identifies gaps in intelligence. It reviews and forwards all-source intelligence products to the G2 operations for inclusion with other intelligence products, analysis, and dissemination. Supported by the USAF weather team and the corps topographic team, the ASPS conducts situation and target development functions using IPB and other methodologies. It supports the G2 operations in collection planning and targeting. It continuously monitors the division PIR and IR and recommends changes and information requirements as necessary. It continuously monitors the collection

plan to identify gaps and adjusts it to the changing tactical situation. It supports the EW effort of the fire support cell with intelligence on the enemy radio electronic combat (REC) threat. It can also provide electronic order of battle data.

The ASPS routinely converts reported intelligence and information from sources into all-source intelligence using a basic production process. The ASPS receives data in two forms, It receives information—data that has not been subjected to correlation or analysis. It also receives *processed intelligence*. It correlates and analyzes both types of data to provide refined intelligence. Entrance into ASPS is controlled. All personnel working within the ASPS must have proper security clearances and be cleared for access to sensitive compartmented information (SCI).

Two field artillery intelligence officers (FAIOs) are normally provided by the FSE to work within the ASPS—normally one per shift.

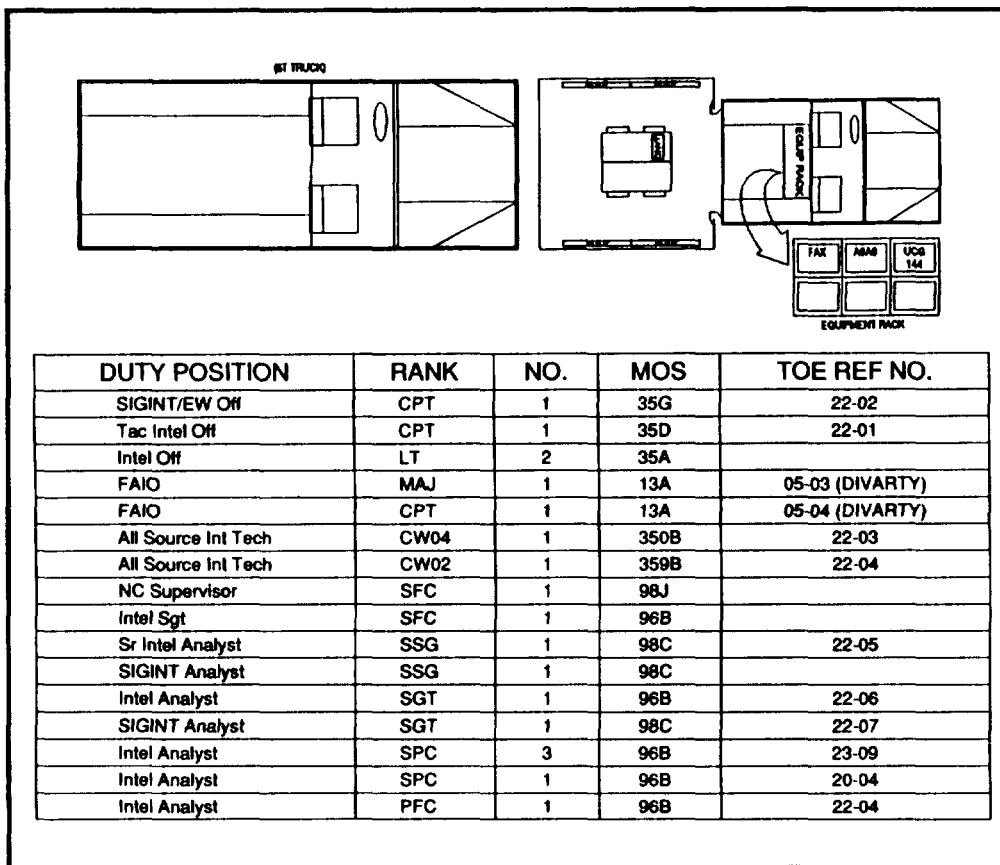

Figure 2-45. ASPS vehicle and personnel

The FAIO is a vital link in the rapid identification and attack of time-sensitive HPTs. FAIOs must have SCI access to function within the ASPS. They must have a detailed understanding of the threat, the target development process, and targeting process actions. The FAIOs—

- Are key participants on the targeting team.
- Provide the interface between the targeting team and the ASPS.
- Provide attack system requirements for accuracy and timeliness to the ASPS.
- Help the G2 section translate targeting time requirements into guidance for collection and ensure the collection plan focuses, in part, on detecting HPTs.
- Provide the G2 section with expertise on FA target acquisition systems capabilities and limitations.
- With ASPS, determine and inform the targeting team when major changes in the tactical situation warrant reevaluation of the HPT list and attack guidance matrix.
- With ASPS, evaluate information received to produce targets, If necessary, the FAIO will ask the G2 to focus collection assets to further develop selected targets.

- Nominate valid targets to the FSE for attack. The FAIO may pass identified HPTs and other targets directly to the fire control element at the DIVARTY CP or, if approved by the command cell, directly to a firing unit.

- Coordinate with the collection manager to ensure that TDA data is acquired for selected targets. With the ASPS, the FAIO analyzes TDA data and informs the FSE of the results of this analysis.

Provide new coordinates to the FSE if the target has moved.

Staff Weather Officer Element

The US Air Force provides a USAF weather team (WETM) to the division to provide weather support to division operations. The equipment used by the WETM is normally organic to the division. The WETM cell performs its functions from a HMMWV and SICPS tent located a short distance from the main CP (in its massed configuration) (Figure 2-46). All equipment used by the USAF WETM is provided through the division TOE. The USAF WETM performs its functions throughout the division's AO. The staff weather officer (SWO) works for and reports to the division G2. The WETM provides weather observations

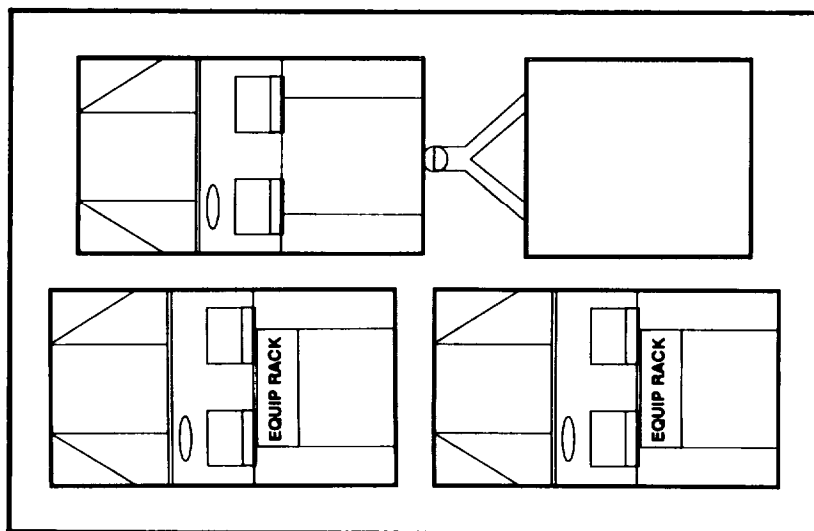

Figure 2-46. SWO vehicles

and forecast support to the division. It works closely with the ASPS and terrain team to integrate weather information into the IPB.

The WETM supports the division's current and future operations in trafficability, maneuverability, visibility, and soldier comfort. It provides the G2 a daily 24-hour operations forecast and continuous input to the IPB process as well as producing basic wind data for the NBC. On demand or as required, the WETM updates and changes forecasts for a two- to six-hour time frame. The WETM obtains its weather information from a variety of sources, both internal and external to the division. Figure 2-47 depicts the weather operations concept currently used within the division.

Using either the Goldwing or UAWS systems, the WETM has contact with weather satellites on a 24-hour basis. The USAF WETM has contact with Army theater forecast facilities and available weather satellite sources using TOE equipment. The combination of surface and upper air observations, theater forecasts, and reception of satellite cloud imagery of current conditions are used to make forecasts. The WETM can also communicate with the WETM element at the

corps CP. Within the division, the WETM interfaces with brigade and battalion S2s for current weather information in their AOs. Combining all available sources of weather information provides the USAF WETM with an accurate description of current weather conditions in the division AO and is part of the data base used to forecast and evaluate weather effects on operations. The SWO also uses divisional and Air Force transient aircraft for pilot reports of weather encountered either en route or exiting from a target area. Collectively, all of these sources provide the most accurate forecast possible to support tactical operations.

Division Terrain Team

The division terrain team is attached to, and supervised by, the division G2. The section performs its functions within a HMMWV with standard shelter and SICPS tent located a short distance from the main CP (in its massed configuration) (Figure 2-48). The team consists of eight soldiers to support continuous operations.

The terrain team's primary role is to support the IPB process through production of the modified combined obstacle overlay (MCOO) and

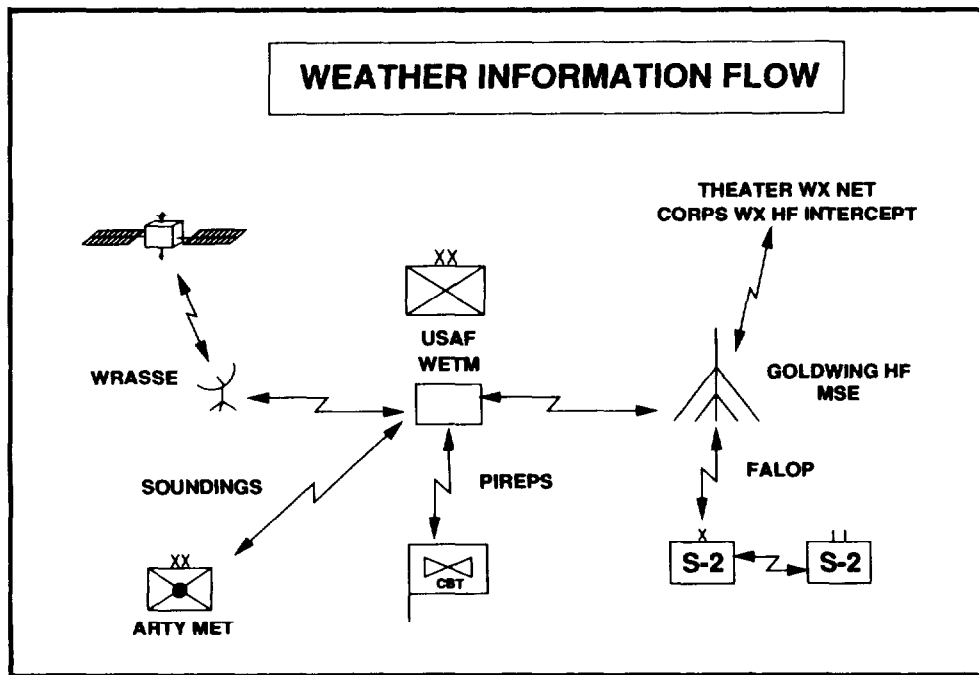

Figure 2-47. Division weather data

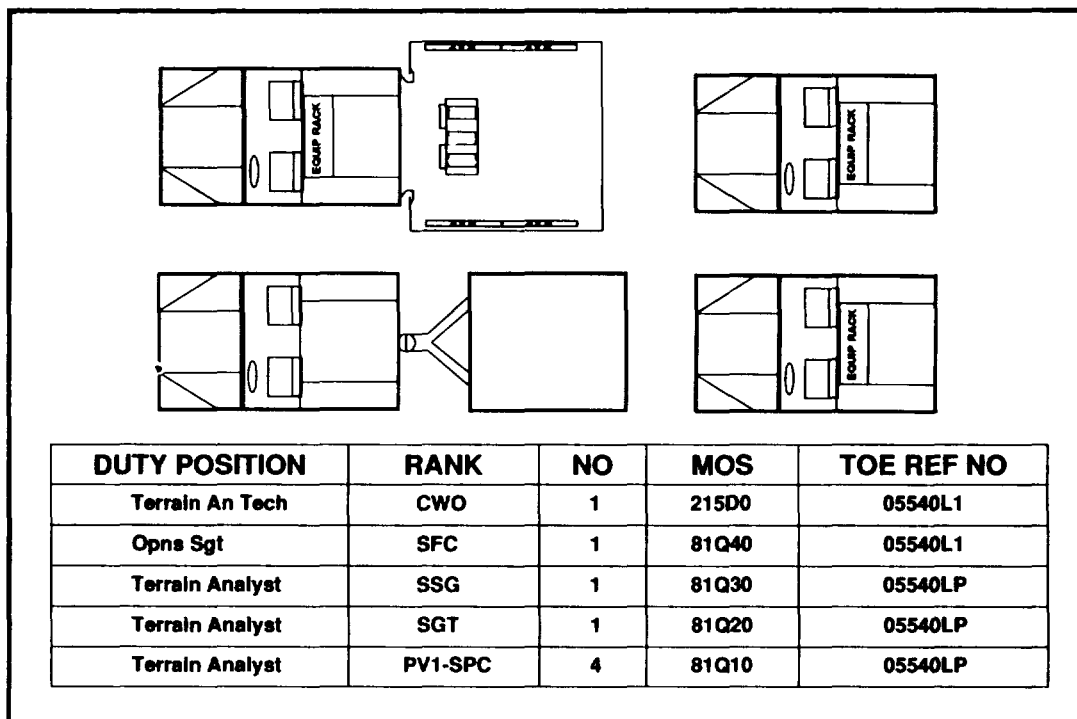

Figure 2-48. Division terrain team

related terrain analysis overlays. It supports the planning cell with analysis of trafficability, routes, choke points, zones of entry, and obstacles. The team supports the G2 collection manager with visible area infiltration route, helicopter landing zone (HLZ) and drop zone (DZ), cover and concealment analysis for siting intelligence collectors, and development of long-range surveillance detachment (LRSD) target folders. It supports targeting with line-of-sight (LOS), mobility, and cover and concealment studies, and with structural information on man-made targets. Additionally, the team responds to terrain requests for information (RFIs).

THE REAR COMMAND POST

The rear CP is an extension of the main CP. It focuses on the command and control of all elements located within the division's rear AO. It also synchronizes rear operations for the division battle. The rear CP normally contains three cells—headquarters, operations, and CSS (Figure 2-49). This austere structure controls all the elements functioning, residing, or transiting through the rear AO. Units should not enter the division's rear area without prior coordination

with the rear CP. This will clarify and approve routes and locations of bases or base clusters, integrate this information into the security plan, and address requirements for sustainment. The rear CP passes this data to the main CP for information and the main's terrain management requirements.

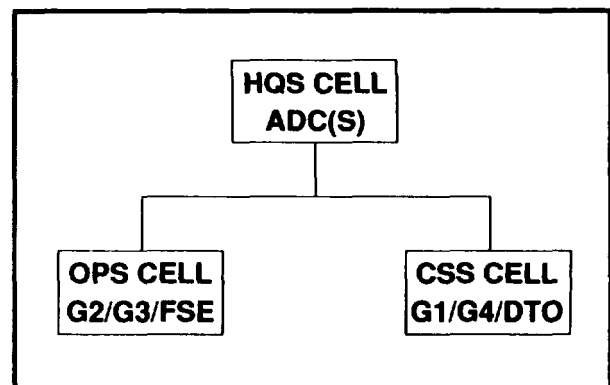

Figure 2.49. Rear CP structure

The rear CP normally collocates with the DISCOM CP in the established DISCOM base within the division support area (DSA) in the division rear area. They are located side by side or

end to end for ease of transit and coordination. The rear CP also collocates with the DISCOM CP to use DISCOM organic life support and security. This collocation does not imply that together they constitute the rear CP. On the contrary, they are

two separate and distinct CPs with different but critical functions which require extensive cooperation and coordination (Figure 2-50). The rear CP is primarily concerned with terrain management, security of the rear area, tactical

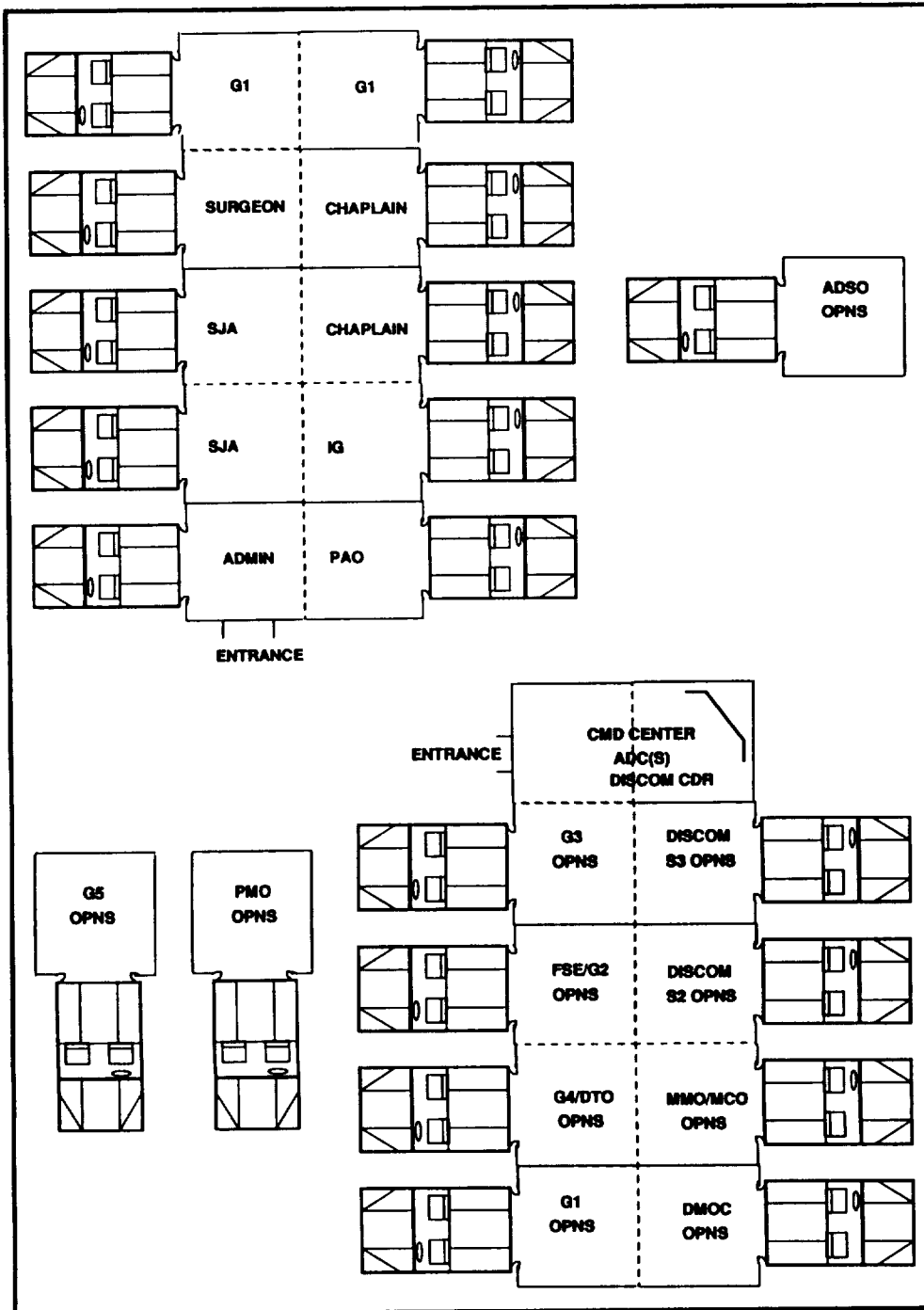

Figure 2-50. Collocated rear and DISCOM CPs

and logistics movement within and through the rear area, and synchronization and direction of sustainment. The DISCOM CP is primarily concerned with the execution of sustainment. The rear CP contains elements from the assistant division commander for support (ADC-S), G2, G3, FSE, G1, G4, DTO, ADSO, G5/CIMIC, provost marshal (PM) operations, and G1 support element.

The rear CP's most critical role is to synchronize and integrate rear operations with close and deep operations. The rear CP and the DISCOM CP jointly analyze future division plans for their impact on current and future rear operations to ensure logistics and personnel support is available. The rear CP deconflicts tactical and nontactical moves where needed and controls them when required. The rear CP manages the terrain in the rear area. It assigns units to bases, designates base clusters when necessary, and appoints commanders for bases and base clusters. The rear CP coordinates and synchronizes rear security operations. It integrates base defense plans and designates and coordinates tactical combat forces (TCFs). The rear CP monitors activity in the brigade's rear, adjacent divisional rear areas, and corps rear area to prevent potential conflicts with the division's rear operations. Additionally, the rear CP monitors close and deep operations. When augmented, it may assume control of the fight if the main and TAC CPs can no longer function.

Information at the rear CP is normally displayed on 1:50,000 (or 1:00,000) scale maps and 1:250,000 scale maps. The following paragraphs describe a functionally based CP.

Headquarters Cell

The ADC-S is a brigadier general who normally functions as the rear operations commander. He is responsible for the conduct of both the rear and DISCOM CPS for the division battle. The headquarters cell consists of one vehicle (Figure 2-51). The ADC-S accomplishes C² of rear operations through the rear CP. He routinely makes decisions that affect the conduct of operations of the rear area without prior approval or coordination with the main CP. However, he always makes his decisions within the division commander's specific guidance or intent. Any

decision made by the ADC-S or the rear CP must be transmitted immediately to the main CP to coordinate and synchronize the division battle. He receives unscheduled informal briefings, and ensures coordination among the operations cell, CSS cell, and DISCOM CP. He normally remains at the rear CP but, when required, he travels throughout the rear area to synchronize operations. His primary concern is to sustain the division's deep, close, and rear operations.

Rear Operations Cell

The rear operations cell functions from HMMWVs and SICPS tents. A small active duty element mans it until augmentation personnel arrive. It is responsible for terrain management, security, and movement deconfliction and control. The cell maintains the rear operations map (1:50,000) and the intelligence/FSE map (1:50,000) and, when required, manages specific terrain from individual map sheets (1:50,000). The operations cell monitors close operations to ensure rear operations respond to current and future requirements. Until the operations cell is augmented, risk is accepted in continuous operations and the number and types of functions that can be performed. The operations cell is divided into three elements—operations, intelligence, and fire support.

G3 Operations Element

The operations element functions from a HMMWV and SICPS tent and is responsible for terrain management of the division rear area, deconfliction of tactical and nontactical movement, control of movement, and security of rear operations (Figure 2-52). Responsibilities include coordination of response and tactical combat forces and use of host nation assets. The operations element continuously monitors close operations and adjacent rear operations. It apprises the rear operations commander of significant events which impact on the conduct of rear operations.

The division G3 provides an officer and NCO, augmented by an operations NCO and generator operator-driver. One of the operations NCOs is on duty at all times. The G3 officer sets his schedule based on the situation. The generator-operator maintains the vehicle and generator. He assists the operations NCO whenever possible.

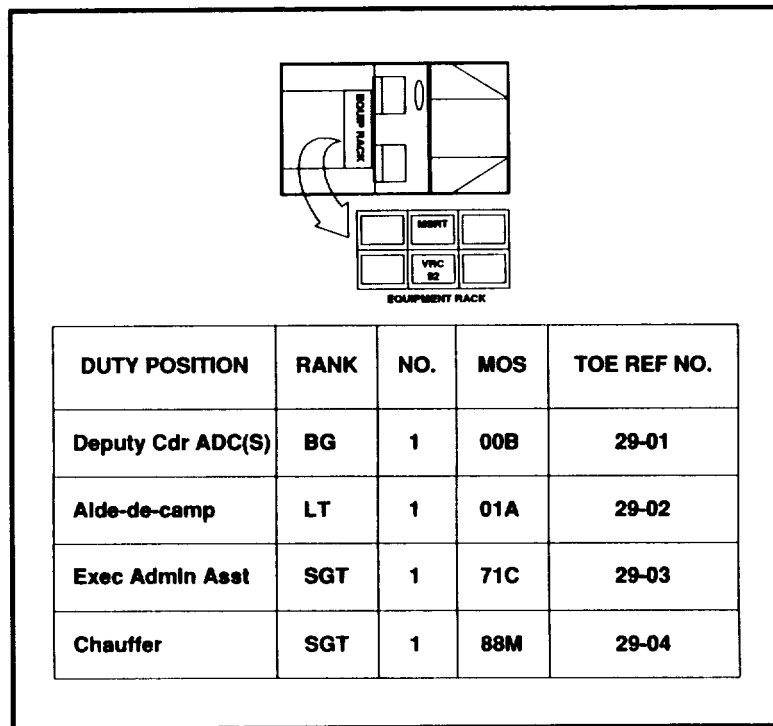

Figure 2-51. Headquarters cell vehicles and personnel

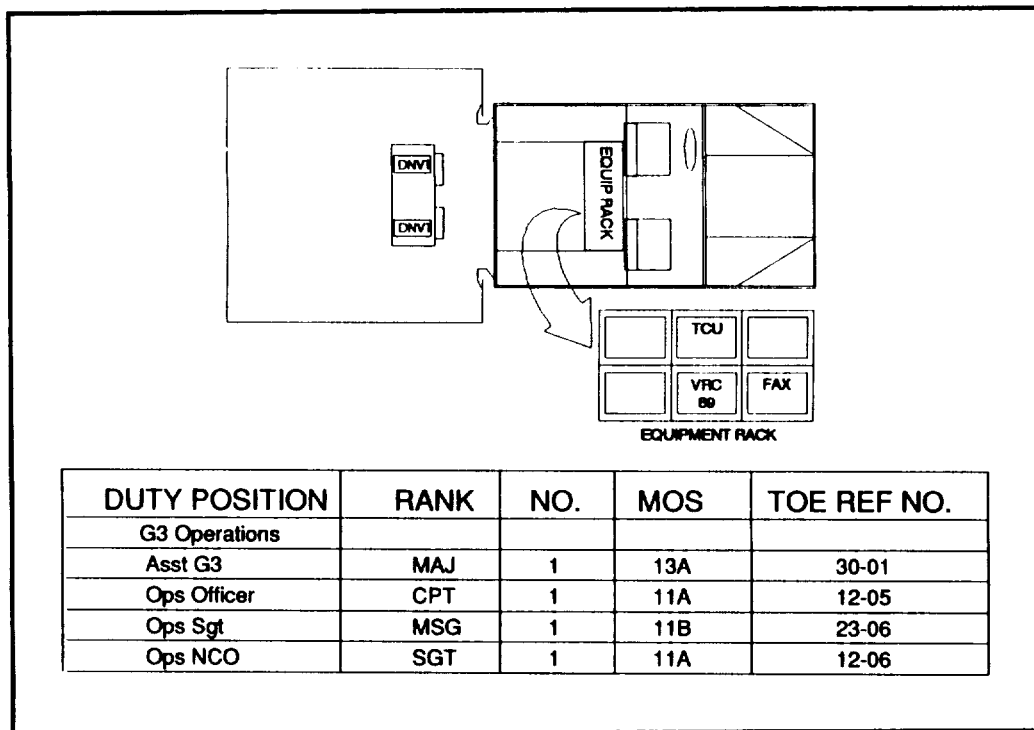

Figure 2-52. G3 operations cell vehicle and personnel

The operations NCO concentrates on terrain management to position the division's support units to meet mission requirements. As bases are formed and base clusters designated, he recommends base cluster commanders and headquarters to the G3 officer. The G3 approves or adjusts these recommendations on his perceptions of the current situation. The operations NCO posts only base markers on the 1:50,000 operations map. The G3 officer designates base clusters by drawing a line around clustered bases and giving them unique identification. He adjusts them as often as needed to ensure he does not overextend the operations cell's span of control.

The operations map shows brigade boundaries, assembly areas, base locations, base cluster designations, main supply routes (MSRs), location of combat forces in the rear area, and last known frontline trace. Unit symbols are usually limited to brigades or separate battalions to limit clutter and posting time. The operations map has the most current close and rear operations tactical information in the rear CP.

The G3 operations element works closely with the PM operations element located nearby. The PM element coordinates traffic control measures when needed, security of designated critical assets, and employment of MP assets. The rear operations element also coordinates with the G3 operations cell in the main CP to designate or dedicate the division's tactical combat force. It also continually monitors its need for commitment. The G5 coordinates host nation assistance. The rear operations element also coordinates the positioning, status, and security of signal assets with the ADSO element. When engineer, AD, or other units are under the control of the rear CP, the rear operations element exercises direct control of each unit. Each supporting unit establishes either a command post near the rear CP or provides a LO to ensure the units' activities are properly integrated, synchronized, and coordinated.

The G3 operations in the rear CP maintains charts and an operations map to see the rear operations battlefield and provide required information to the G3 operations cell at the main CP. The operations map should depict—

- Rear operations graphics.
- Location of designated bases and base clusters.
- Location of MSRs and their status with traffic control points (TCPs).
- Location of response forces.
- Location of designated or dedicated TCF and graphics.
- Locations and routes of transiting units.
- Location of all CPs in the rear area.

Word charts depict the rear CP's task organization with the unit's status, and base and base cluster security status.

The gumball chart at Figure 2-53, page 2-66, shows those elements normally located in the rear area which rear command post G3 operations monitor through spot reports and commander's situation reports. Each category displays combat and maneuver capability of known or potential units in the rear area under the OPCON of the rear CP G3 operations. The rear G3 operations provides this data to the G3 at the main CP.

G2 Intelligence Element

The intelligence element shares a HMMWV and SICPS tent with the FSE (Figure 2-54, page 2-66). It is responsible for continuous IPB and a systematic watch of the rear area. It supplements IPB products received from the main CP to illuminate rear area terrain, enemy capabilities, and the enemy's most probable courses of action (COAs) within the rear area. The intelligence element also manages the overall division counter-intelligence effort, coordinating closely with the PM and G5 to accomplish refugee screening and rear area intelligence collection. The intelligence element recommends rear area PIR to the division G2 and develops the rear area reconnaissance and surveillance (R&S) plan for ADC-S approval. The intelligence element also exercises oversight over the division enemy prisoner of war (EPW) interrogation facility, screens interrogation reports for relevance, and passes significant reports to the G2 at the main CP and to rear area consumers. The intelligence element consists of a G2 officer, an NCO, and an intelligence analyst until augmentation assets arrive.

- Current operations maneuver graphics.

ELEMENT	Vehicles	TOWs	Atk Helos	Arty	CL III	CL V	Pers	Comments
MP	<input type="checkbox"/>	<input type="checkbox"/>	<input type="checkbox"/>	<input type="checkbox"/>	<input type="checkbox"/>	<input type="checkbox"/>	<input type="checkbox"/>	
TCF	<input type="checkbox"/>	<input type="checkbox"/>	<input type="checkbox"/>	<input type="checkbox"/>	<input type="checkbox"/>	<input type="checkbox"/>	<input type="checkbox"/>	
FA	<input type="checkbox"/>	<input type="checkbox"/>	<input type="checkbox"/>	<input type="checkbox"/>	<input type="checkbox"/>	<input type="checkbox"/>	<input type="checkbox"/>	
ADA	<input type="checkbox"/>	<input type="checkbox"/>	<input type="checkbox"/>	<input type="checkbox"/>	<input type="checkbox"/>	<input type="checkbox"/>	<input type="checkbox"/>	
EN	<input type="checkbox"/>	<input type="checkbox"/>	<input type="checkbox"/>	<input type="checkbox"/>	<input type="checkbox"/>	<input type="checkbox"/>	<input type="checkbox"/>	
	<input type="checkbox"/>	<input type="checkbox"/>	<input type="checkbox"/>	<input type="checkbox"/>	<input type="checkbox"/>	<input type="checkbox"/>	<input type="checkbox"/>	
	<input type="checkbox"/>	<input type="checkbox"/>	<input type="checkbox"/>	<input type="checkbox"/>	<input type="checkbox"/>	<input type="checkbox"/>	<input type="checkbox"/>	

Figure 2-53. Rear CP critical combat systems assessment

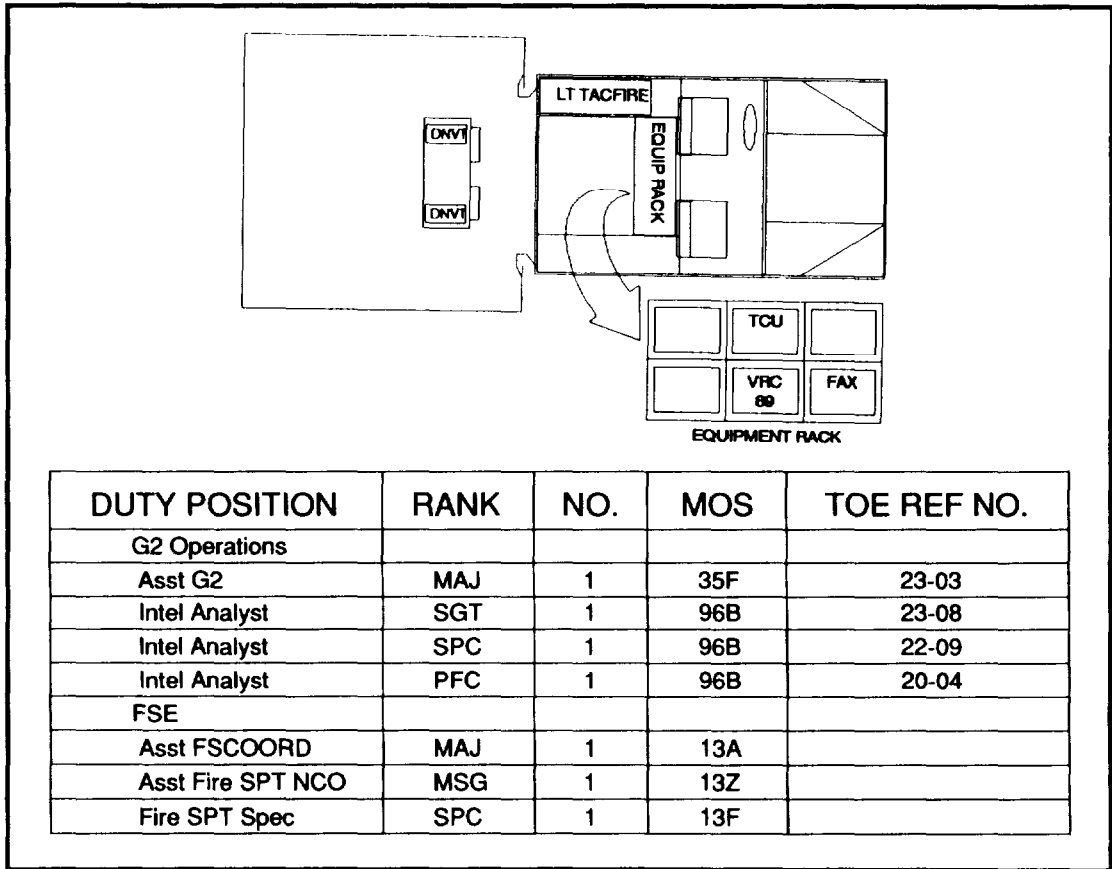

DUTY POSITION	RANK	NO.	MOS	TOE REF NO.
G2 Operations				
Asst G2	MAJ	1	35F	23-03
Intel Analyst	SGT	1	96B	23-08
Intel Analyst	SPC	1	96B	22-09
Intel Analyst	PFC	1	96B	20-04
FSE				
Asst FSCOORD	MAJ	1	13A	
Asst Fire SPT NCO	MSG	1	13Z	
Fire SPT Spec	SPC	1	13F	

Figure 2.54. G2/FSE operations vehicle and personnel

The officer and NCO are scheduled on opposite shifts; the intelligence analyst is scheduled as the situation dictates. The intelligence analyst assists with posting of both the intelligence and operations maps.

The G2's understanding of the friendly situation is *essential* for the conduct of rear area IPB and development of the R&S plan. The intelligence element's map should depict in minimum detail the current situation of the enemy forces opposing the division's frontline forces.

The rear CP G2 element maintains one 1:50,000 scale map (which it shares with the FSE) and a 1:250,000 scale map to track the following items:

- Rear area graphics.
- Locations of enemy activities as reported by supporting units.
- Locations of MI and EW elements supporting the rear CP.
- Locations of anticipated landing zones (LZs), DZs, and air and ground avenues of approach.
- High-value targets within the rear area.
- Base and base cluster security and reconnaissance graphics.

Charts required by the rear CP's G2 include the rear area's PIR and the task organization of MI and EW units supporting the G2 in the rear.

The rear CP G2 maintains gumball and killboard charts similar to those used in the TAC and main CPs. The gumball chart depicts units that directly support the intelligence effort in the rear. The killboard charts reflect known enemy units operating in the rear area.

Fire Support Element

The division rear CP FSE is composed of DIVARTY personnel designated by the DIVARTY commander and augmented with reserve personnel when reserve components are activated. Functioning from the rear CP operations cell, the FSE is responsible for fire support for rear AOs. The division rear CP FSE must also initiate detailed coordination with the DISCOM

CP which collocates with the division rear CP. The rear CP FSE—

- Plans and coordinates fire support for base and base cluster defense plans, response operations, and TCF operations.

- Coordinates the composite rear operations fire support plan with the division main CP FSE, corps FSE, rear operations centers (ROCs), and host nation support headquarters as required.

- Coordinates with the division main CP FSE for on-call or preplanned fires to assist in fire support for rear operations.

- Forwards requests for immediate additional fire support for rear operations to the main FSE.

- Coordinates plans for fires and positioning of fire support assets in the division rear area. Specific items requiring coordination include radio nets for fire requests; communications-electronics operations instruction (CEOI), call sign, and communications security (COMSEC); lines of authority and command; and liaison and FSO requirements and duties.

- Maintains information and status on all fire support assets accessible by and responsive to the division rear CP.

- Plans for and incorporates rear CP reserve component augmentation into the rear CP FSE operations.

The G2 and FSE share a 1:50,000 scale map within the rear operations cell. The intelligence-gathering capabilities of fire support units support the compatibility of these two functions sharing the same map. The G3 operations map also maintains most information required by the FSE to coordinate fire support such as location of base and base clusters and location of the TCF. Fire support information on this map which the FSE normally maintains is as follows:

- Location of direct support artillery units supporting the rear operations (battalion and battery) with range fans.

- Location of organic unit mortars with range fans.

- Current or proposed locations of artillery units transiting the rear area.

- Rear area fire control measures and graphics.

The rear command post FSE maintains charts depicting the rear area fire support organization for combat, and designated rear area high-value targets.

The combat capability status of field artillery is maintained on the same type of charts used by the TAC and main CP FSEs. The rear CP FSE only tracks the status of those fire support units supporting the rear operations. Changes in the status of support are rapidly posted and forwarded to the main CP FSE.

Assistant Division Signal Officer Element

The division's signal battalion provides a small ADSO element to the rear CP to support rear operations and signal support. Its functions for the rear CP are the same as those for the main CP. The ADSO element at the rear CP works for the senior G3 officer in the operations cell. The ADSO element functions from a HMMWV and SICPS tent (Figure 2-55).

Provost Marshal Element

Also working under the supervision and coordination of the rear operations cell is the PM element. The PM establishes a separate working area near the rear CP. The PM comprises SICPS tents and organic vehicles with radios and electronic equipment hardwired for quick connect and disconnect, remote operations, and rapid displacement (Figure 2-56). From this location, the PM supports the division battle and rear operations. However, the PM must maintain the flexibility to send representatives to the main and TAC CPS during critical times for planning and coordination subject to METT-T.

The division PM provides the staff planning, direction, supervision, and coordination of the organic MP company and all supporting MP units and law enforcement activities throughout the division's AO. Units within the division forward all requests for MP support through the division PM operations cell at the rear CP. Units assigned or attached to a brigade with a direct support MP platoon should coordinate with the brigade S3 for their support requirements. The cell continually updates the rear operations cell on MP assets throughout the division's AO. The PM performs the priority tasks of battlefield circulation control, rear area security, and EPW operations and law and order missions as required.

To accomplish battlefield circulation control missions, the PM tasks MP units to conduct route reconnaissance and surveillance of critical main supply and tactical movement routes. Military police routinely operate TCPs, roadblocks, checkpoints, and holding areas at critical points along the route. They also conduct straggler and refugee control, allowing the PM to assess the impact on current and future operations.

The PM employs his MP and other OPCON assets in a security role to conduct area reconnaissance to detect unexpected attacks by the enemy in the rear area. Military police units screen the rear and flanks of affected units during special operations (for example, a TCF operation). In this role, the MPs can identify, intercept, and destroy small enemy forces before they can close on their objectives. Area damage control operations are conducted to seal off an area engaged by indirect attacks by artillery or air. Working closely with the rear operations G2 cell, the PM employs MPs to collect information from friendly units, civilians, local authorities, and civilians about suspected enemy and terrorist activity.

The PM coordinates EPW activities to establish centralized EPW collection points within the division's rear AO. Capturing units evacuate all their prisoners to a collection point. Then the MPs escort the EPWs from the brigade area to the divisional collection point.

G5 Element

The G5 is responsible for all civil-military operations supporting the division battle. The G5 element locates near the rear CP and PM element to coordinate and synchronize host nation support activities. The primary functions of the G5 are to—

- Identify and coordinate unit requirements for local resources.
- Minimize local population interference with military operations.
- Advise the commander and staff on the division's legal and moral obligations to the local population.
- Plan routes, collection points, and assembly areas that least interfere with tactical and logistics activities, and establish control over the movement of refugees.

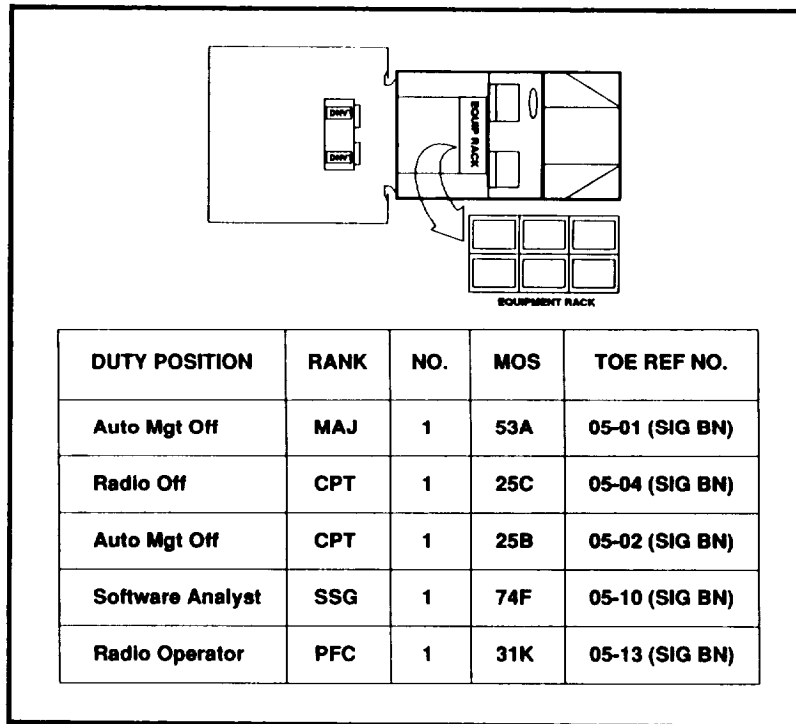

Figure 2-55. ADSO vehicle and personnel

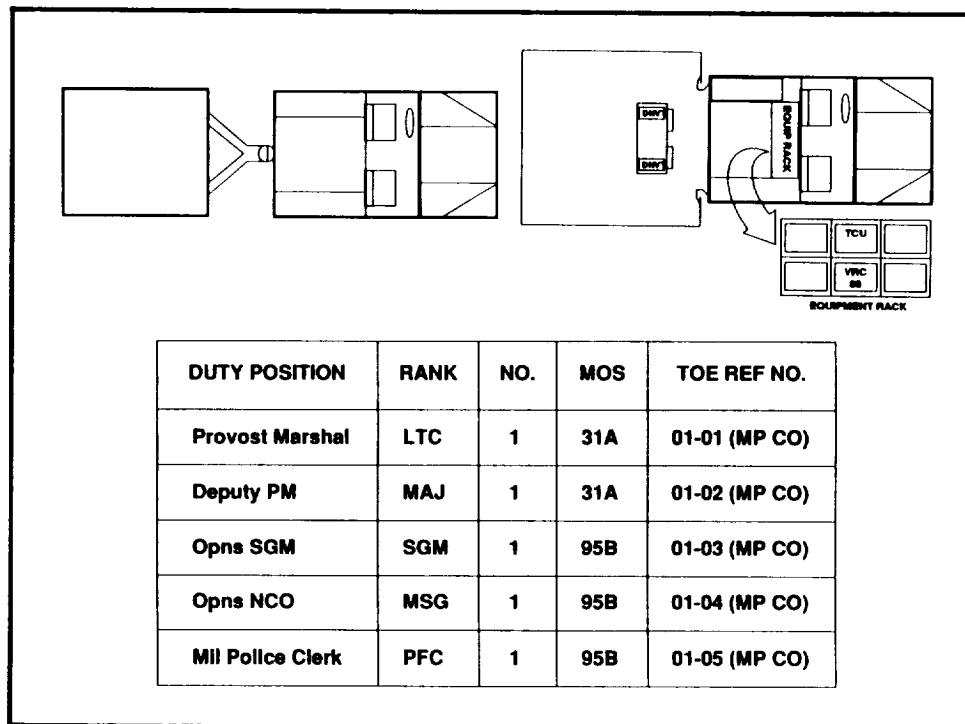

Figure 2-56. PM vehicles and personnel

- Coordinate all host nation requirements for the division. Those resources not vital to the survival of the civilian population are coordinated and provided for military use. The division's requests for local resources should reflect the minimum required for division elements to effectively sustain and conduct operations.

The G5 normally requires augmentation from division assets until the arrival of reserve civil affairs element. A technique for augmenting the G5 element is to use a portion of the staff judge advocate (SJA) element to support the G5 operations. (The skills of the SJA personnel can easily support the missions and functions of the G5.) With the arrival of division and or reserve civil affairs (CA) units, the G5 element becomes the core and supervisor of the division civil-military operations center (CMOC). Figure 2-57 shows G5 vehicle and personnel.

Combat Service Support Cell

The major functions of the CSS cell are to plan and coordinate sustainment operations—man, arm, fuel, fix, move, and sustain soldiers and their systems. The cell also interfaces with the main CP, the rear CP operations cell, and subordinate units. The CSS cell functions from within its HMMWVs and SICPS tents. The G1 and G4 elements each provide personnel to the main CP G3 operations cell. These G1 and G4 personnel talk directly with the G1 and G4 elements in the rear CP, updating them on current and future operations. The CSS cell is divided into two elements—logistics and personnel.

Logistics Element

The logistics element comprises the G4 and DTO sections. (Figure 2-58.) The G4 plans, coordinates, directs, and synchronizes the division's

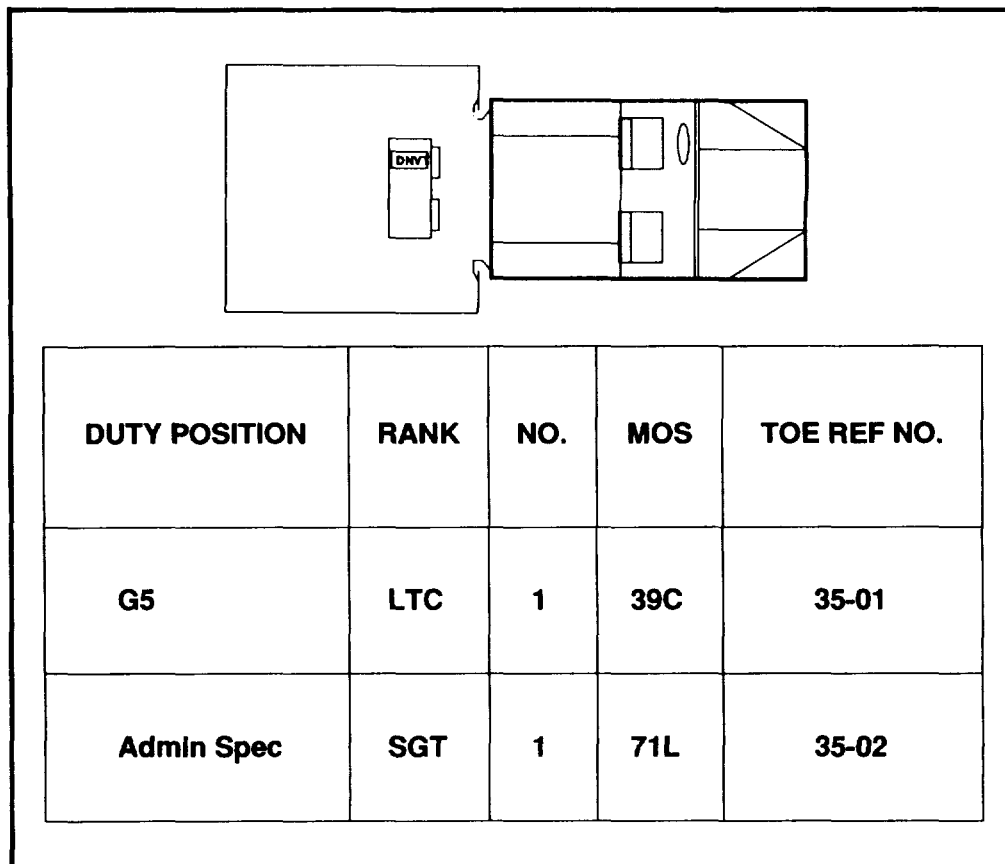

Figure 2-57. G5 vehicle and personnel

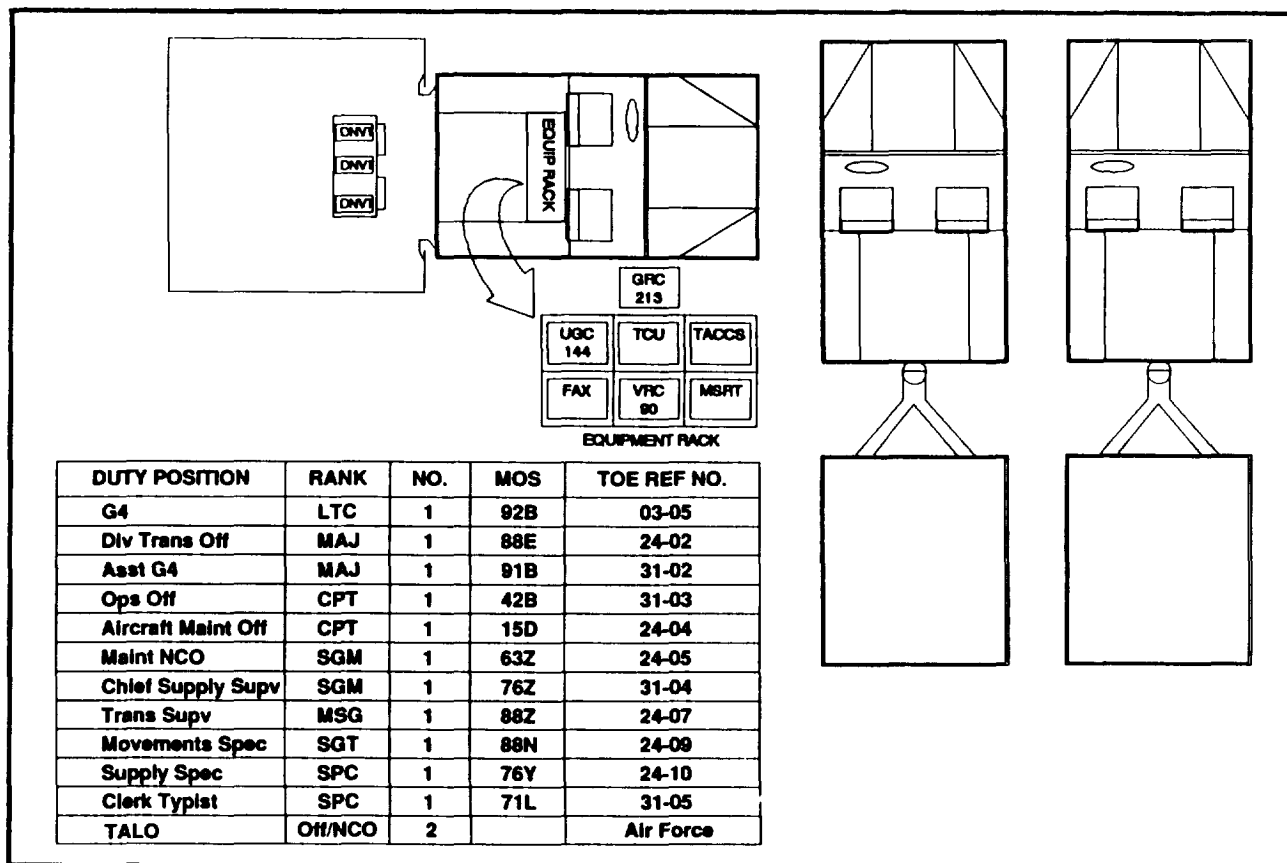

Figure 2.58. G4/DTO vehicle and personnel

arm, fuel, fix, and move operations. The G4 coordinates logistics support which exceeds the DISCOM's capability with the corps rear CSS cell and corps support command (COSCOM). One member of the DTO element functions within the G3 plans at the main CP.

During movement operations involving the entire division, DTO and PM personnel may locate temporarily at the TAC CP. This allows them to assist the TAC CP staff in monitoring the progress of the move and coordinate contingencies occurring during the move. The DTO, DISCOM movements control officer (MCO), and PM representative assist in planning and enforcing movement priorities.

The TALO works from the rear command post G4. He facilitates the coordination of cargo aircraft to support division operations. He also does not routinely maintain formal charts or post operations maps. However, he has certain

information requirements—runway availability and projections, cargo handling capability, and locations of brigade medical treatment facilities and landing areas.

Personnel Element and G1 Support Element

The G1 personnel section (Figure 2-59) plans, coordinates, directs, and monitors all personnel service support operations. The G1 directs the activities of the personnel section. When the division moves to combat operations, the G1 focuses primarily on personnel replacement management, strength management, casualty management, coordination of external support requirements (postal, morale, welfare, and recreation), and medical evacuation. He develops replacement priorities from input by the G3.

The G1 support element, located near the rear CP, coordinates and executes the personnel element functions. This element comprises the major sections of the G1 and special staff (such as

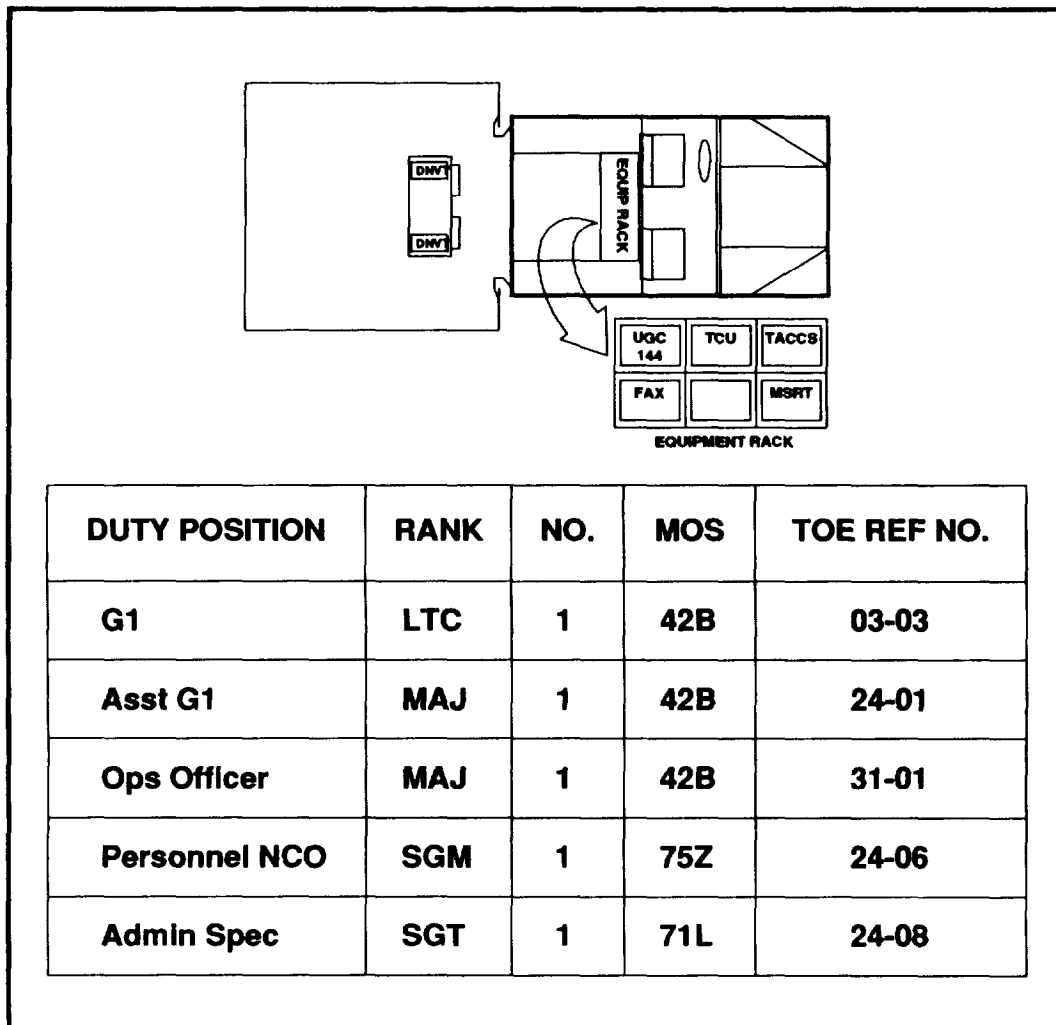

Figure 2-59. G1 operations vehicle and personnel

inspector general (IG), public affairs officer (PAO), chaplain, surgeon, and SJA). Elements from a corps personnel service company normally augment the personnel section. Personnel functions are physically executed from within several SICPS tents. This includes strength management, casualty reporting, replacement operations, health service support (HSS), chaplain services, and legal services. It also includes morale support activities, postal services, and public affairs (PA). Finance support is provided by the corps finance unit assigned to the division area.

The vehicles used for the G1 support cell are organic to the G1 or supporting organizations. Each vehicle has communications and computer equipment mounted inside it. Each vehicle is configured and wired to support operations through remoting without having to download all equipment each time the element is set up. Figure 2-60 depicts one configuration for setting up the G1 support element with organic vehicles. Some sections are more fully manned than others. *The G1 should distribute labor equitably throughout the cell to ensure each element's critical functions are performed to support continuous operations.*

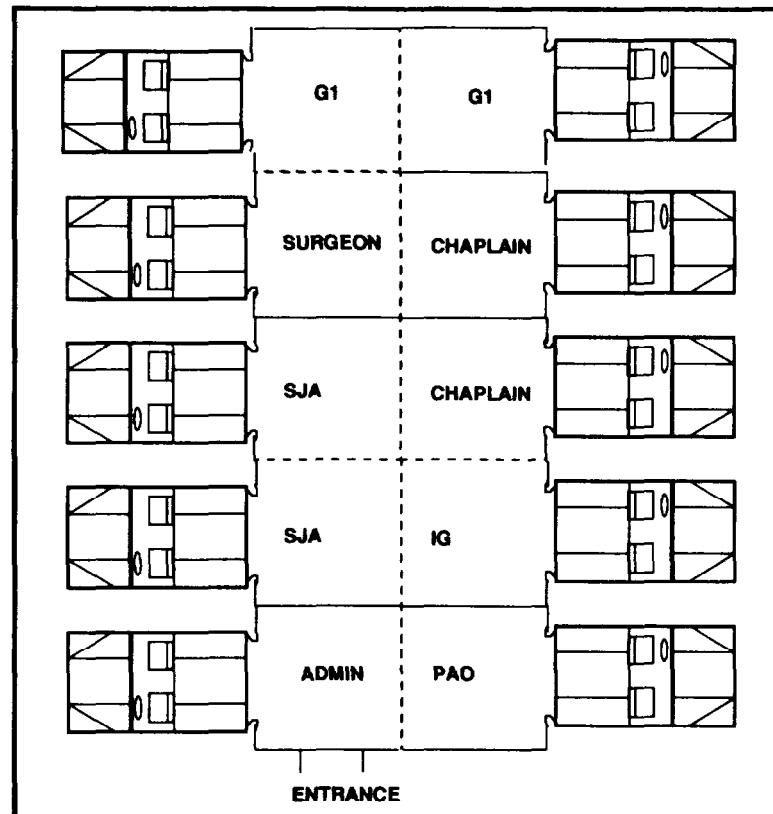

Figure 2.60. G1 support element configuration

The G1 support element functions under the supervision of the chief of the strength management division. (See Figure 2-61, page 2-74.) Its primary responsibilities are personnel strength and accountability reports, personnel replacement operations, casualty reporting, and postal operations. The G1 also serves as the coordination point and liaison for limited finance operations.

Personnel accounting and strength reporting is delivered to the division rear in the hasty (manual) format when the division is committed to combat operations. The G1 receives strength-related reports directly from brigades, separate battalions and squadrons, and separate companies by any means available. All strength reports submitted to the G1 from organic subordinate units include the strength of attached and OPCON units under their control. The strength accounting and management section consolidates these reports into a divisional strength report and immediately provides it to the G1 element in CSS operations. The unit SOP states the frequency of

strength reporting. Normally, it is only when a significant change has occurred that affects the unit's combat power. This reduces the number and frequency of reports to those deemed critical. The G1 consolidates these reports into a divisional strength report and furnishes it to the corps adjutant general (AG).

Replacement operations is the most critical battlefield function of the division G1. The G1 works closely with the rear CP G3 and G4 elements to develop and implement replacement priorities. He considers input from unit strength management reports and knowledge of current and future tactical and sustainment operations. The G1 coordinates the assets required to aid rapid transmission of priority replacements to receiving units. He must maintain close coordination with the strength managers in the G1 support cell to anticipate future requirements. He also coordinates with the medical manager to manage return-to-duty soldiers.

DUTY POSITION	RANK	NO.	MOS	TOE REF NO.
Pers Mngt Supv	MSG	1	75Z	33-02
Team Sergeant	SFC	3	11B	33-03
Supply Spec	SPC	1	76Y	33-04
Clerk	PFC	1	71L	33-05
Supply Spec	PFC	1	76Y	33-06

DUTY POSITION	RANK	NO.	MOS	TOE REF NO.
Strength Acct Off	MAJ	1	42B	34-01
Mil Personnel Tech	CW04	1	420A0	34-02
Pers Actions Supv	MSG	1	75Z	34-03
Pers Mngt Supv	SSG	1	75C	34-04
Sr Pers Mngt Spec	SGT	2	75C	34-05
Sr Pers Actions Spec	SGT	1	75E	34-06
Pers Mngt Spec	SPC	2	75C	34-07
Pers Actions Spec	SPC	1	75E	34-08
Pers Mngt Spec	PFC	4	75C	34-09
Pers Actions Spec	PFC	1	75E	34-10

Figure 2-61. G1 support personnel

Casualty management and forecasting are critical to the division's combat posture. Casualty forecasting is an integral part of the G1 support cell in CSS operations. It is accomplished by analyzing recent battle losses and overlaying this information with the replacement flow to the division from corps. Battalion S1s should collocate one personnel and administration center (PAC) member within the medical company of each support battalion to ensure that casualty data is submitted accurately and timely. In addition, it is a good back-up system to ensure continuity of casualty reporting.

Postal operations manages and operates a postal network to move, collect, and sort mail, critical spare parts, and medical supplies for the deployed force. The G1 provides information to the DS postal platoon servicing the division to update the postal delivery scheme. The G1 arranges transportation for onward movement requirements to brigade support areas (BSAs) or combat trains. Once mail reaches the BSA, it is placed on the logistics package convoy supporting the unit.

Staff Judge Advocate Section. The SJA section supports the division by providing professional legal services as required. While the division fights, judge advocates focus primarily on operational law issues. They—

- Monitor the care and treatment of captured or detained persons and refugees.
- Determine the legality of targets and plans.
- Interpret rules of engagement (ROE).
- Requisition or confiscate property for military use.

If the situation permits, SJA section personnel may supplement the G5 cell to augment their austere staff. As the battlefield stabilizes, SJA section personnel provide the full spectrum of legal services, including, but not limited to—

- Assistance to soldiers with their personal legal affairs.
- Disposition of violations of the Uniform Code of Military Justice (UCMJ) by article 15, UCMJ, or court-martial.

- Settlement of foreign claims by foreign claims commissions.

- Preparation and review of contracts for locally available goods and services.

- Assistance in the investigation and disposition of alleged war crimes. Figure 2-62, page 2-76 shows the SJA section's organic vehicle and personnel.

Public Affairs Section. The PA section responds to all queries from the news media. The public affairs officer—

- Regulates media correspondents' activities within the division's AO.

- Briefs the media on division operations and ground rules for media coverage of those operations.

- Reviews material scheduled for release to the media for OPSEC limitations or requirements.

- Provides guidance to news media personnel concerning field censorship procedures and guidelines.

The PAO does not conduct censorship activities. Figure 2-63, page 2-76 shows the PA section's organic vehicle and personnel.

Division Surgeon Section. This section plans, coordinates, synchronizes, and integrates HSS operations to support the division battle. The division surgeon functions from the G1 support cell under the supervision of the division G1. He coordinates HSS initiatives through the G1 and exercises technical control of all HSS activities within the division. The division surgeon is assisted by his immediate staff and the staff of the division medical operations center (DMOC). Organic to the division HQ is the surgeon's section and treatment team. The surgeon's section provides administrative support while the treatment team provides echelon 1 (unit level) medical support to the division HQ. Corps ground and air patient evacuation and surgical assets in support of the division normally preposition with DISCOM medical companies. The division surgeon, assisted by the DMOC, supervises and synchronizes division-wide HSS.

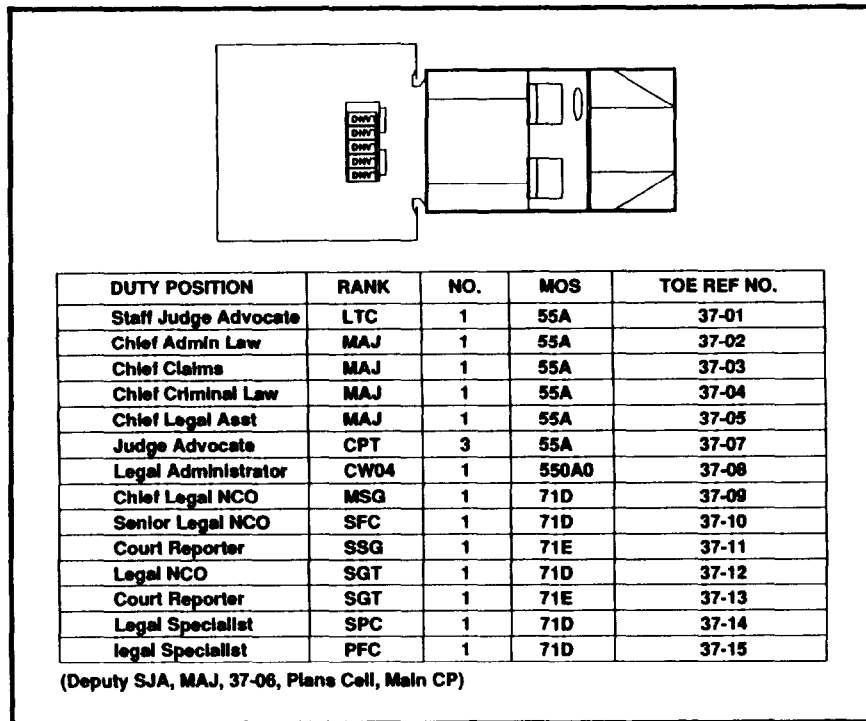

Figure 2-62. Staff Judge advocate vehicle and personnel

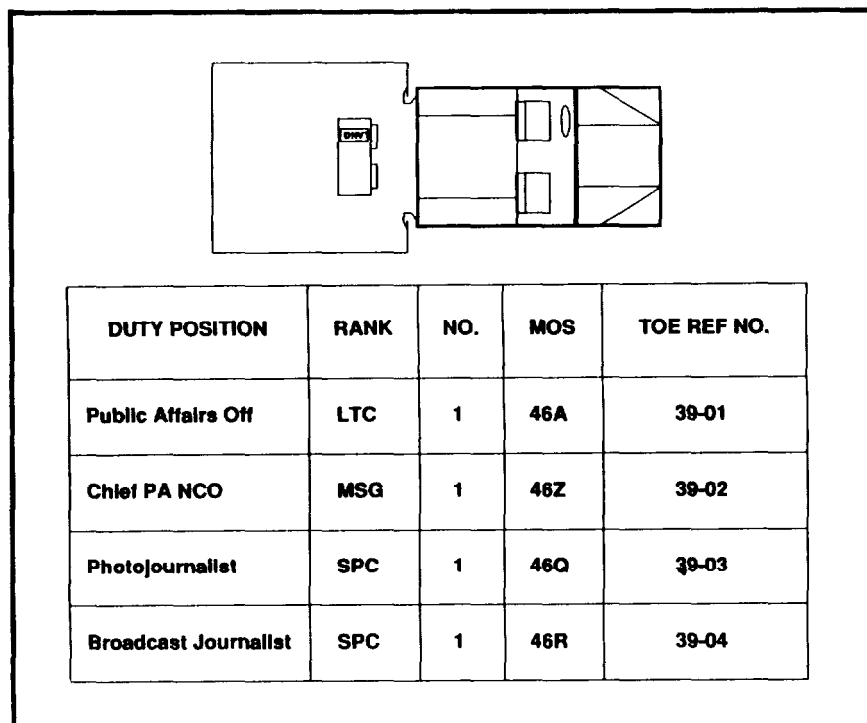

Figure 2-63. Public affairs vehicle and personnel

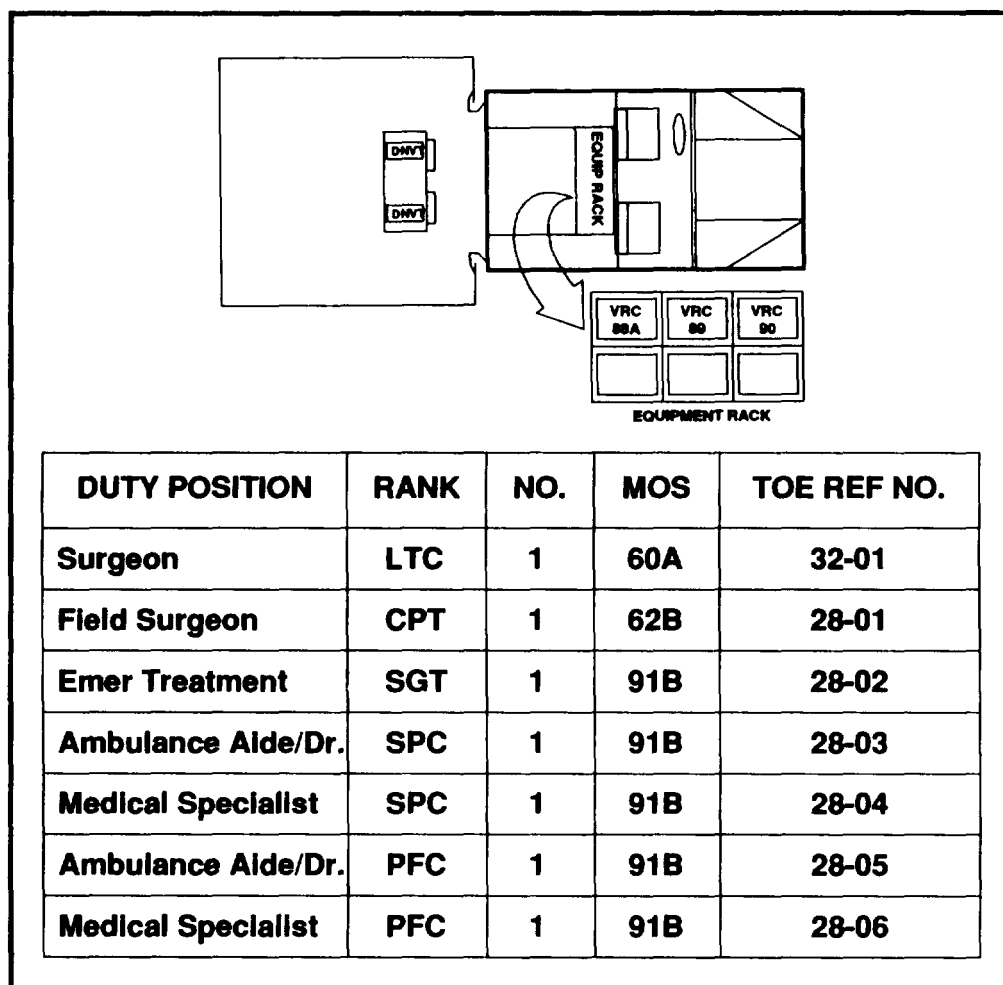

Figure 2.64. Division surgeon vehicles and personnel

The primary means of medical evacuation is by ground and air ambulance. Any vehicle capable of transporting casualties may be used if medical vehicles are not available. Organic echelon 1 medical elements in support of maneuver units evacuate patients to unit aid stations. The forward support medical companies station ambulances with supported maneuver battalions and establish ambulance exchange points. The medical company evacuates the patient from the battalion aid stations to patient transfer points (ambulance exchange point) or directly to a treatment facility when required. Corps evacuation assets evacuate patients from the division area to corps medical facilities. Figure 2-64 shows the division surgeon section's organic vehicles and personnel.

Inspector General Section. This section provides division commanders with a continuous objective assessment of their command's effectiveness. The IG accomplishes missions through inspections, assistance, investigations, follow-ups, teaching and training, planning, analysis, and information resource management. The effort during combat is not as extensive as during garrison operations, but no less important. The IG examines and measures the division's economy, efficiency, discipline, morale, *esprit de corps*, and readiness.

The IG positions himself where soldiers can file IG reports for investigation and other IG services and he can monitor the battle and receive guidance and direction from the commander.

Figure 2-65 shows the IG's organic vehicles and personnel.

Division Chaplain Section. This section provides area religious support for units in the division's AO. During combat operations, chaplains normally cover combat units and medical facilities. The division's chaplain and assistant chaplain assign chaplains and coordinate their activities within the division. Figure 2-66 shows the division chaplain's organic vehicles and personnel.

Division Band. The band's primary mission is to provide music during peace and war, promoting troop morale and unit esprit, and to support civil military operations. Under most situations, the mission of playing music is practical only when the division is not committed to tactical operations. When the division is committed to combat, the division band may become a combat multiplier. There are several roles that band personnel can fill, if the roles are properly identified, and personnel are trained and equipped for them during peacetime.

Security augmentation is the band's most common secondary role in combat. When performing its security mission, the band is routinely placed OPCON to the provost marshal. The PM may assign personnel to provide security to the division CPS, augment the military police response forces as a dismounted infantry platoon, or operate a holding area for EPWs. Each of these missions requires that band personnel undergo specific training and be issued equipment not normally on their TOE.

The band may perform other secondary missions, working under the supervision of the appropriate staff leader. The duration and activity of the secondary mission, however, must be considered. The band must be able to quickly resume its primary mission when called on. If at all possible, unit integrity should be maintained when assigning the band a secondary mission. Figure 2-67, page 2-80, shows the organic vehicles and personnel of the division band.

Reserve Component Augmentation

When the rear CP is augmented by reserve components, the rear CP operations cell becomes fully capable of continuous operations. The reserve component augmentation normally consists

of 19 personnel (Figure 2-68, page 2-81). The operations cell is now better able to plan, coordinate, and direct rear security operations, deconflict and control movement, manage the terrain allocated to the division rear command, and plan and direct area damage control operations on a continuous basis.

With reserve augmentation, a base defense and area damage control element is added. This allows the operations cell to assist base and base cluster commanders to plan and coordinate base defenses, plan area damage control, and assess damage and reconstitution as needed. With the addition of this reserve augmentation element, the bases and base clusters within the division's rear area report directly to the base defense operations element. It maintains the G3 operations map of current locations and the defensive status of each base and base cluster. It works closely with the FSE and G2 elements to coordinate intelligence gathering and fire support coverage. This element operates with the PM using mobile teams, configured according to need.

Life Support Area Operations

The LSA is an area normally occupied by the division's headquarters commandant and higher headquarter's commander as a base of operations to support the main and TAC CPS with food, fuel, ammunition, and maintenance. Figure 2-69, page 2-81, depicts the personnel and vehicles from the HHC which normally form the nucleus of the ISA. Typically, the LSA is large and noisy and poorly lit. Its mission and size make it ponderous to move. *The staff G3 and the headquarters commandant must consider how to employ it to ensure that it becomes a combat multiplier rather than a restraining factor.*

The LSA can effectively support CPS in two ways. Both are driven by whether the division is committed or noncommitted to tactical operations. If the division is not committed to combat and security, and movement is not a factor, the LSA should be near the division's main CP. Being in a noncommitted status and located well to the rear of harm's way allows more risk in employing the LSA forward to provide effective support. This location facilitates the LSA's support of preparation for combat tasks and establishment of sleeping quarters and hygiene facilities for CP personnel.

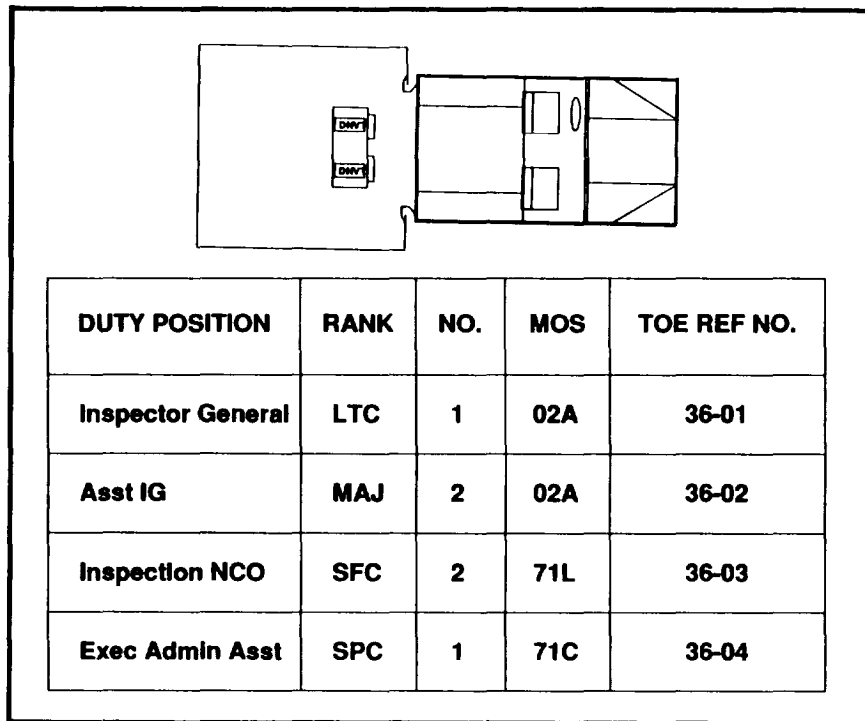

Figure 2-65. Inspector general vehicle and personnel

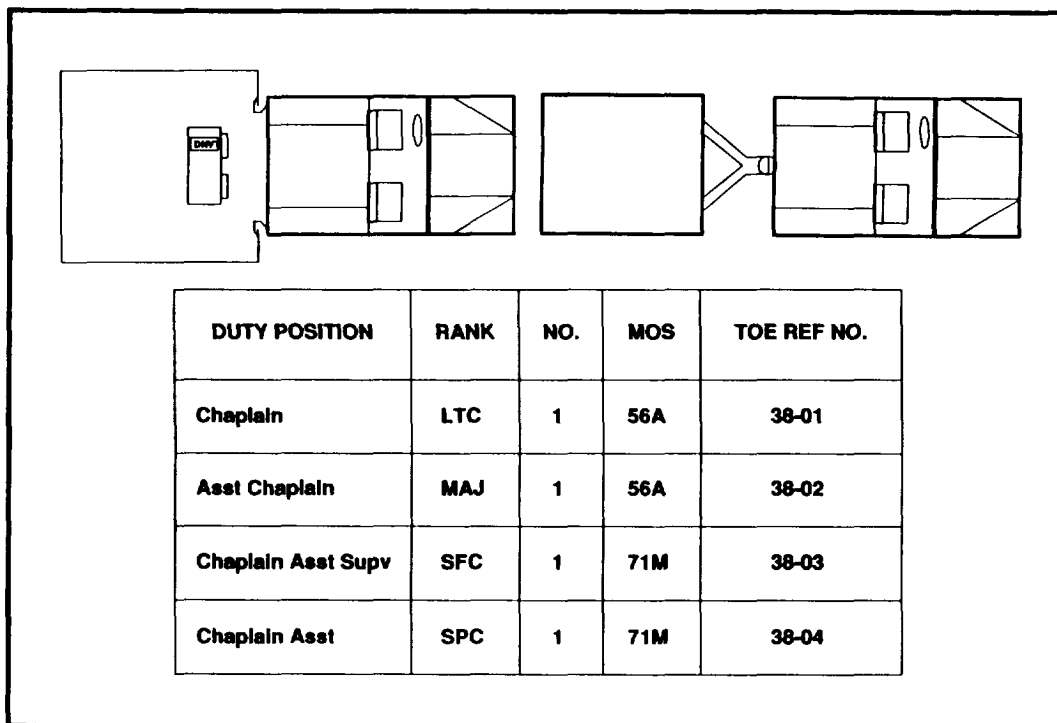

Figure 2-66. Division chaplain vehicles and personnel

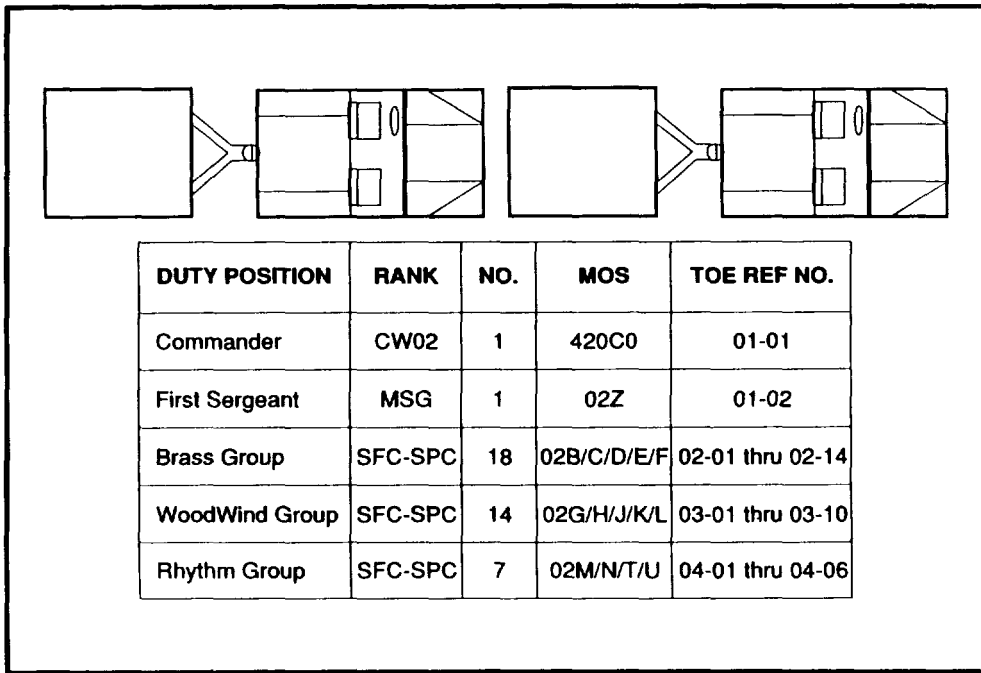

Figure 2-67. Division band vehicles and personnel

When the division is committed, the LSA should remain in the rear area near the rear CP. There, its size and lack of mobility does not represent a security risk for the main CP. The LSA supports the main and tactical CPS by logistics packages (LOGPACs) specially tailored to meet the requirements of the CP. The packages function in the same manner as in brigades and battalions. Small, mobile contact teams provide required or emergency maintenance to the CP. They perform only essential maintenance or repairs until time and situation permit a more sustained effort. The HQ company of the DISCOM provides internal supply, food service, and unit-level maintenance for vehicles, generators, and construction equipment organic to the division rear CP.

THE ASSAULT COMMAND POST

During contingency operations, the assault CP normally provides temporary C² until the main CP deploys into an AO. Normally austere, its specific design is driven by METT-T and may vary from deployment to deployment. The assault CP controls all elements committed to the close operation, and conducts those critical C² functions required to support the division in tactical

operations as it initially deploys into an unsecure, hostile contingency area.

To be effective, the assault CP is normally sequenced in the deployment to arrive as soon as possible after the initial assaulting brigade or the airhead or beachhead has been secured or a perimeter established. It fights the current fight with division forces on the ground, synchronizing the flow of follow-on units into the AO and phasing them into the fight to expand and secure the airhead or beachhead. It also begins initial planning for the conduct of future operations (sequels). It serves as the division C² link early in the deployment between division forces on the ground, in the air, and at home station and the higher corps or JTF headquarters. It continues this function until the remainder of the division C² systems arrive. Normal doctrinal functions can be performed at the TAC, main, and rear CPs as they arrive in the deployment sequence.

There may be no set design for the assault CP. Each situation or contingency mission demands different requirements, depending on the specific mission. However, each assault CP is designed around a basic functional structure of G3 operations, plans, G2 operations, fire support element

POSITION	RANK	NUMBER	MOS
OPERATIONS ELEMENT			
OPERATIONS OFF	LTC	1	54A
OPERATIONS OFF	MAJ	1	31A
OPERATIONS SGT	MSG	1	11Z
OPERATIONS ASST	SPC	1	11B
CLERK/TYPIST	SPC	1	71L
INTELLIGENCE ELEMENT			
CI OFFICER	CPT	1	35E
CI AGENT	SSG	1	97B
CI SGT	SSG	1	96B
FIRE SUPPORT ELEMENT			
FIRE SPT OFF	MAJ	1	13A
FIRE SPT SGT	SSG	2	13F
BASE DEFENSE/AREA DAMAGE CONTROL ELEM			
OPERATIONS OFF	MAJ	1	11A
OPERATIONS OFF	CPT	2	11A
OPERATIONS SGT	SSG	1	11B
ENGINEER OFF	CPT	1	21B
ENGINEER NCO	SFC	1	51H
CHEMICAL NCO	SSG	1	54B
OPERATIONS ASST	SPC	1	11B

Figure 2-68. Reserve component personnel augmentation

ELEMENT	TOE PARA	NO. PERS.	VEHICLE SUMMARY
Company HQs	25	6	1 - HMMWV
			1 - 1 1/2 T TRL
			1 - 5T CGO TRK
Food Svc Section	26	12	2 - 5T CGO TRKS
			2 - 400 GAL WTR TRLS
Maint Section	27	7	1 - 5T CGO TRK
			1 - 1 1/2 T TRL
HQs Commandant	5	4	1 - HMMWV

Figure 2-69. LSA vehicles and personnel

within an ALO, signal element, and G4 operations. The size of the assault CP normally depends on the number of airframes available. As a general rule, the assault CP should be deployable in no more than two C141 aircraft. Concurrent with critical functions is a requirement to deploy sufficient personnel for each element to effectively sustain continuous, 24-hour C² functions and operations.

The division TAC CP is often used as the base from which to build the assault CP. It is used with the intent of peeling off functions as the main and rear CPs are established and eventually reverting back to the original TAC CP with its traditional functions. A concept of a base case assault CP is presented at Figure 2-70. This assault CP deploys with nine HMMWVs, eight SICPS shelters, and sufficient personnel to perform critical C² functions. The HMMWVs contain all communications and computer equipment hard mounted into the rear. This equipment can be used either in the HMMWV, remoted to the SICP shelter, or in a combination of both. A description of the roles and functions of each area follows along with personnel and equipment layouts.

Command Center

The command center is the information hub of the assault CP. It is the focal point into which all assault CP staff elements provide all information obtained to enable the commander to see the battlefield. It is where tactical decisions are made. The command center is the workplace for the ADC-M and CG and serves the same functions, although abbreviated, as the command center in the main CP.

The command center maintains its capability to see the battlefield and unit combat capability through reporting criteria based on CCIR. It contains a 1:50,000 scale map of the AO with current selected friendly and enemy unit locations as fed from the staff sections. Personnel manning the command center come from the division chief of staff section. A Cof S for the assault CP must be designated to facilitate continuous and efficient staff support to the operation. Communications are provided to the command center by remoting from the ADC-M HMMWV attached to the command center. The command center is located centrally within the assault CP configuration to facilitate the flow of information with the

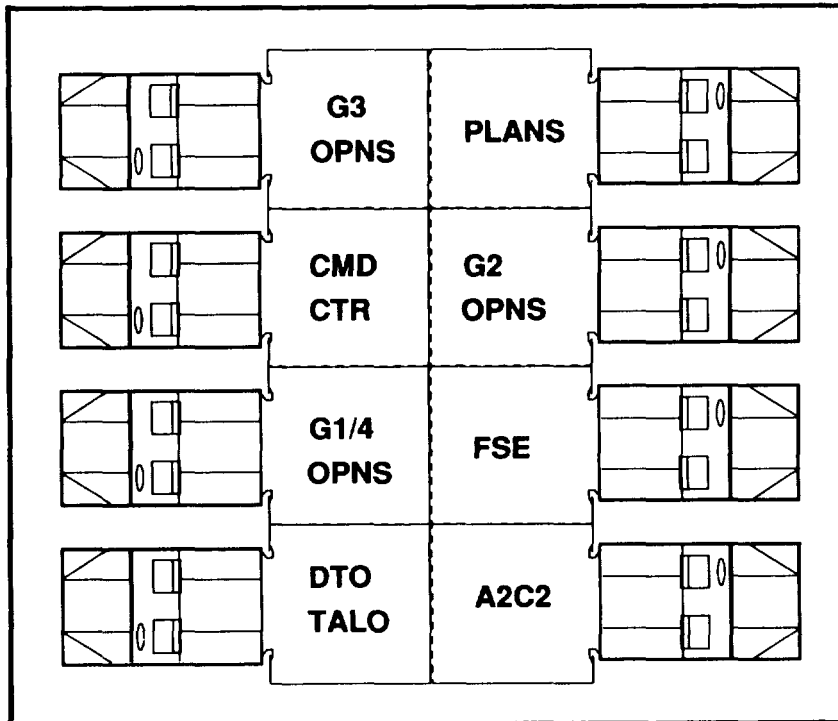

Figure 2-70. Example assault command post

other staff elements. Figure 2-71 presents the command center with required equipment and personnel.

Plans Element

The plans element is included in the assault CP to facilitate future division operations. It consists of selected plans element personnel from the division main CP plans element. During the deployment phase of the operation, the plans element supports the G3 operations element by developing FRAGOs and warning orders to support the current operation. At some point, however, the division will begin planning for a subsequent mission. This will be the task of the plans element. Having deployed early and working in support of the G3, the plans element develops a current, up-to-date working knowledge of the strengths, disposition, and capabilities of units on the ground and those incoming. This knowledge assists the plans element in the planning process parallel to the continuing conduct of the close operation. When the main CP deploys and begins establishing itself, the plans element moves from the assault CP to the main CP to resume normal planning with current information. The plans element should locate as close to the G3 and G2 operations and command center as

practical. A diagram of the plans element and required personnel is shown at Figure 2-72, page 2-84.

G3 Operations Element

The G3 operations element controls all combat and CS forces (less fire support) deployed on the ground to support the current operation. It comprises primarily the TAC CP G3 element personnel and is augmented as needed. It serves the same functions as described for the TAC CP G3 operations element. It is the NCS for the assault CP and receives, logs, and posts information received from tactical and situation reports. It issues warning orders and FRAGOs to control and fight the current and close operation. It maintains the combat capability status of all committed forces two levels down. It analyzes information received and provides required information to the command center to support the CCIR. Included in the personnel requirements for the G3 operations element is a SJA officer to inform the commander on legal ramifications of operations and COAs. This officer must be knowledgeable of the legal system, procedures, and laws of the host nation. The SJA is a critical element in the assault CP during the early stages of the deployment. The G3 operations element is located adjacent to

DUTY POSITION	RANK	NO.	MOS	TOE REF NO.
Commander	MG	1	OOB	03-01
Deputy Cdr (ADC-M)	BG	1	OOB	02-01
Chief of Staff	COL	1	O2A	04-01
Aide de Camp	CPT	1	O2A	03-06
Aide de Camp	LT	1	O1A	02-07
CSM	CSM	1	00Z	03-07
SGS	MAJ	1	O1A	04-02
LO Off	CPT	3	11A	04-03
LO NCO	SGT	3	11B	04-04
Admin Asst	SSG	1	71C	04-05
Admin Asst	SGT	1	71C	02-10
Admin Asst	SPC	1	71C	04-05
Clerk Typist	SPC	1	71L	04-06
Chauffeur	SSG	1	88M	03-09
Chauffeur	SGT	1	88M	02-11

Figure 2-71. Assault CP command center

DUTY POSITION	RANK	NO.	MOS	TOE REF NO.
Chief Plans	MAJ	1	11A	23-01
Asst Plans Off	MAJ	1	11A	18-01
Asst Plans Off (ADA)	MAJ	1	14B	05-01 (ADA BN)
Asst Plans Off (ADE)	MAJ	1	21B	
Asst Plans Off (LOG)	MAJ	1	92A	24-03
Asst Plans Off (INT)	MAJ	1	35D	23-02
Deputy SJA	MAJ	1	55A	37-06
Asst Plans Off (FA)	CPT	1	13A	
Asst Plans Off (AVN)	CPT	1	15A	
Asst Plans Off	CPT	2	11A	23-05
Ops NCO (NBC)	SFC	1	54B	
Ops NCO (FA)	SFC	1	13Z	
Ops NCO	SGT	1	11B	23-07
Clk Typist	PFC	1	71L	23-09
Clk Typist	PFC	1	71L	

Figure 2-72. Assault CP plans element

the command center. Figure 2-73 shows the G3 operations element's required equipment and personnel.

G2 Operations Element

The G2 operations element in the assault CP performs those functions primarily associated with the TAC CP G2 operations section. The assault CP G2 operations is primarily manned by the personnel of the TAC CP and augmented as required. They receive, post, and analyze intelligence data and reports received from committed

units and provide them to the command center and higher headquarters. They also receive intelligence information from higher intelligence assets and pass it down to major subordinate units' S2s for their use. They maintain that information from intelligence assets required to support the CCIR to see current and future enemy capabilities and COAs and assess friendly intelligence asset capabilities. Figure 2-74 shows the G2 operations element's required equipment and personnel.

DUTY POSITION	RANK	NO.	MOS	TOE REF NO.
Asst G3	MAJ	1	11A	02-04
Opns Off	MAJ	1	11A	02-03
Opns Off	CPT	1	11B	02-06
Opns SGT	SGM	1	11Z	02-08
Asst Opns SGT	MSG	1	11B	02-09
Opns Asst	SPC	2	11B	02-12
Opns SGT	SSG	2	11B	08-05/06 (OPSEC)
Opns SGT	SGT	2	11B	08-03/04 (OPSEC)
Driver/Gen Opr	SPC	1	11B	19-01 (SWO)

Figure 2.73. Assault CP G3 operations element

DUTY POSITION	RANK	NO.	MOS	TOE REF NO.
Tac Intel Off	MAJ	1	35D	01-01
Tac Intel Off	CPT	1	35C	01-02
Tac Intel Off	CPT	1	35C	08-01 (OPSEC)
Chief GSS SGT	MSG	1	96R	01-03
Intel NCO	SFC	1	96B	08-02 (OPSEC)
Intel Analyst	SGT	1	96B	01-04
Intel Analyst	SGT	1	96B	21-05 (CM&D)
Intel Analyst	SPC	2	96B	20-02/03 (SSO)
Driver	SPC	1	96B	21-06 (CM&D)

Figure 2-74. Assault CP G2 operations element

Fire Support Element

The FSE and ALO in the A2C2 element perform essentially the same functions as those of the TAC CP. Personnel and equipment of the assault CP FSE are those of the TAC CP with required augmentation. The FSE coordinates and synchronizes all fire support assets committed to the current fight. Until the arrival of the DIVARTY HQ and the main CP FSE, the assault CP may perform some of their

functions, depending on the situation. The FSE responds to requests for fire support and tactical air support from units committed to combat operations. It also sequences incoming fire support assets into the fight as they arrive. It maintains information to support the commander's critical fire support information requirements and assesses the combat capability of committed units. Figure 2-75 shows the required FSE equipment and personnel.

DUTY POSITION	RANK	NO.	MOS	TOE REF NO.
Asst FSCOORD	MAJ	1	13A	05-02 (DIVARTY)
Target Analyst	CPT	1	13A	05-05 (DIVARTY)
FS Off	CPT	1	13A	12-06 (G3)
FS Asst	SSG	1	13F	05-08 (DIVARTY)
FS SGT	SFC	1	13F	05-07 (DIVARTY)
FS SGT	SGT	1	13F	05-09 (DIVARTY)
FS SPC	SPC	1	13F	05-10 (DIVARTY)

Figure 2-75. Assault CP fire support element

DUTY POSITION	RANK	NO.	MOS	TOE REF NO.
G3 Air	MAJ	1	15B	12-04
Asst G3 Air	CPT	1	11A	23-04
Asst G3 Air	CPT	1	15B	07-03
Airspace Off	CPT	1	15E	10-01 (AVN BDE)
Avn Ops Sgt	SSG	1	93P	10-02 (AVN BDE)
Avn Ops Spec	SPC	1	93P	10-03 (AVN BDE)
ADA Off CPT	CPT	1	14B	05-02 (ADA BN)
ADA Ops Sgt	SFC	1	16S	05-03 (ADA BN)
ADA Asst Ops Sgt	SSG	1	16S	05-04 (ADA BN)
ADA Spec	SPC	1	16J	05-05 (ADA BN)
ALO/ASST	LTC/CPT	2	AIR FORCE	

Figure 2-76. Assault CP A2C2 element

DUTY POSITION	RANK	NO.	MOS	TOE REF NO.
G1	LTC	1	42B	03-03
Asst G1	MAJ	1	42B	24-01
OPS Officer	MAJ	1	42B	31-01
Personnel NCO	SGM	1	75Z	24-06
Admin Spec	SGT	1	71L	24-08
G4	LTC	1	92B	03-05
Div Trans Off	MAJ	1	88E	24-02
Asst G4	MAJ	1	91B	31-02
OPS Officer	CPT	1	42B	31-03
Aircraft Maint Off	CPT	1	15D	24-04
Maint NCO	SGM	1	63Z	24-05
Chief Supply Supv	SGM	1	76Z	31-04
Trans Supv	MSG	1	88Z	24-07
Movements Spec	SGT	1	88N	24-09
Supply Spec	SPC	1	76Y	24-10
Clerk Typist	SPC	1	71L	31-05

Figure 2-77. Assault CP G1 and G4 element

A²C²Element

The A²C² element in the assault CP works for the G3 and coordinates airspace within the division's AO. This element maintains control of airspace to facilitate attack helicopter operations as well as Air Force transport flights into and out of the airfield. It maintains positive control of all

AD assets protecting the AO. Figure 2-76 shows the equipment and personnel requirements of the assault CPA²C² element.

G1 and G4 Element

The G1 element of the assault CP maintains contact with subordinate unit S1s to have an

accurate picture of the personnel strength of committed units. It advises the commander and G3 on the arrival of personnel into the AO. The G1 receives and maintains reports that support the commanders critical personnel information requirements. The primary focus of the G4 is the status of committed unit class I and V in support of the CCIR.

The G4 maintains an accurate status of the quantity and location of critical logistics supplies as they arrive in the AO and recommends their

allocation to the G3 and ADC-M. Located next to the G1 and G4 operations element are the DTO and TALO. These two elements coordinate incoming flights and reception. They also coordinate the disposition of personnel and cargo offloading. They maintain contact with aircraft on the ground, inbound to the AO, and at the departure airfield. They advise the commander on the status of deployment and arrival of division units. Figure 2-77 shows the equipment and personnel requirements of the G1 and G4 element.

CHAPTER 3

OFFENSIVE OPERATIONS

This chapter provides some examples of how the infantry division integrates and synchronizes organic and supporting combat, CS, and CSS assets to conduct offensive operations. It describes these division operations—deliberate attack, penetration, movement to contact, exploitation and pursuit, and follow and support.

Each operation is described as part of a corps operation. The infantry division operation supports the corps commander's intent and concept of operations.

Corps, divisions, and brigades use a variety of tactics and techniques to execute these operations. The tactics and techniques discussed in this chapter are meant to be illustrative in nature. They describe just one way a division may conduct operations.

FUNDAMENTALS

The four general forms of the tactical offense are movement to contact, attack, exploitation, and pursuit. While it is convenient to talk of them as different forms, in reality they flow readily from the one to the other. Different forms of attack may occur throughout the depth of the battlefield simultaneously. An attack may lead to exploitation, and exploitation can lead to pursuit. But there are often occasions when pursuit can be followed by deliberate attack, or deliberate attack can lead directly to pursuit. The ebb and flow of battle opens up many avenues for attack. Victory normally goes to the bold and eludes the commander who can see only the parts and not the whole of the combat.

The forms of maneuver are envelopment, turning movement, infiltration penetration, and frontal attack. They orient on the enemy force, not terrain. The commander selects the form of maneuver which will best achieve his purpose with regard to the enemy. Forms of maneuver and forms of offensive operations complement one another. The forms of maneuver apply equally to traditional battles or to the fluid, extended contact of noncontiguous battlefields. While frequently used in combination, each attacks the enemy in a different way, posing different challenges to the attacking commander.

The primary focus of division offensive deep operations is to interdict by delaying, disrupting, or diverting enemy division reserves (battalion- or regimental-sized counterattack forces); it then shifts to enemy units defending in defensive

positions in depth. Infantry divisions conducting deep operations are limited by the capabilities of their organic weapons systems and will likely require corps weapons systems augmentation, such as MLRS and attack helicopters. The following examples portray the division conducting an infiltration and deliberate attack, operating as part of the corps attack, and as such do not have a deep operation. If the division were conducting a more conventional deliberate attack, then deep operations planning and execution would be appropriate. Refer to Chapter 4, Infantry Division Defense, or an expanded discussion of infantry division deep operations.

The United States signed the Chemical Weapons Convention (CWC) on 13 Jan 93 and, in doing so, effectively renounced the use of chemical weapons (CW) for any reason, including retaliation. The CWC is a major step in the US long-term goal of eliminating the threat of chemical use by achieving a worldwide ban. The United States will now attempt to deter enemy use of chemical (or biological) weapons by—

- Maintaining a strong nuclear, biological, and chemical (NBC) defensive posture.
- Maintaining the military capabilities to deny an enemy a significant military advantage from such use.
- Updating the technology of chemical defense.
- Encouraging universality and compliance with the CWC.

The US acceptance of the CWC has resulted in eliminating or modifying several functions.

Artillery units no longer train for delivery of chemical weapons and the Army does not maintain chemical stocks in a "ready-for-issue" status.

Further, recent US policy changes resulting in the elimination of short-ranged, ground-launched nuclear weapons also eliminated the US Army organic nuclear capability. Consequently, the use of nuclear weapons in support of operations will come from our sister services (Navy and Air Force). Presently, corps is the lowest level at which nuclear fire planning is conducted. The division is responsible for force protection and NBC defense only, for example, issuing strike warnings and conducting vulnerability analysis.

THE DELIBERATE ATTACK

The infantry division normally conducts offensive operations in restricted terrain. It can conduct a deliberate attack to seize key terrain and destroy enemy forces. It attacks with surprise and violence to break the enemy's backbone. This section discusses the tactics and techniques used by the division in a deliberate attack.

In our example, corps has conducted a successful defense and is preparing to transition to the offense. The corps commander estimates the enemy is widely dispersed and at 40 to 60 percent strength. The terrain immediately to the corps front is rugged and difficult for maneuvering heavy units.

Corps requests the infantry division because of its unique capabilities to infiltrate in rugged terrain and to conduct air assault operations. The ability of the infantry division to achieve surprise and concentrate overwhelming combat power in the enemy rear is key to the success of the corps plan.

An extensive corps IPB determines the feasibility of using the infantry division. During the IPB process, enemy forces are located, terrain is analyzed, and risk is determined. The corps provides IPB products to the infantry division during the plans development process.

The corps commander's concept for the attack (see Figure 3-1) is to seize with infantry key choke points (objectives FOX and WOLF) and river

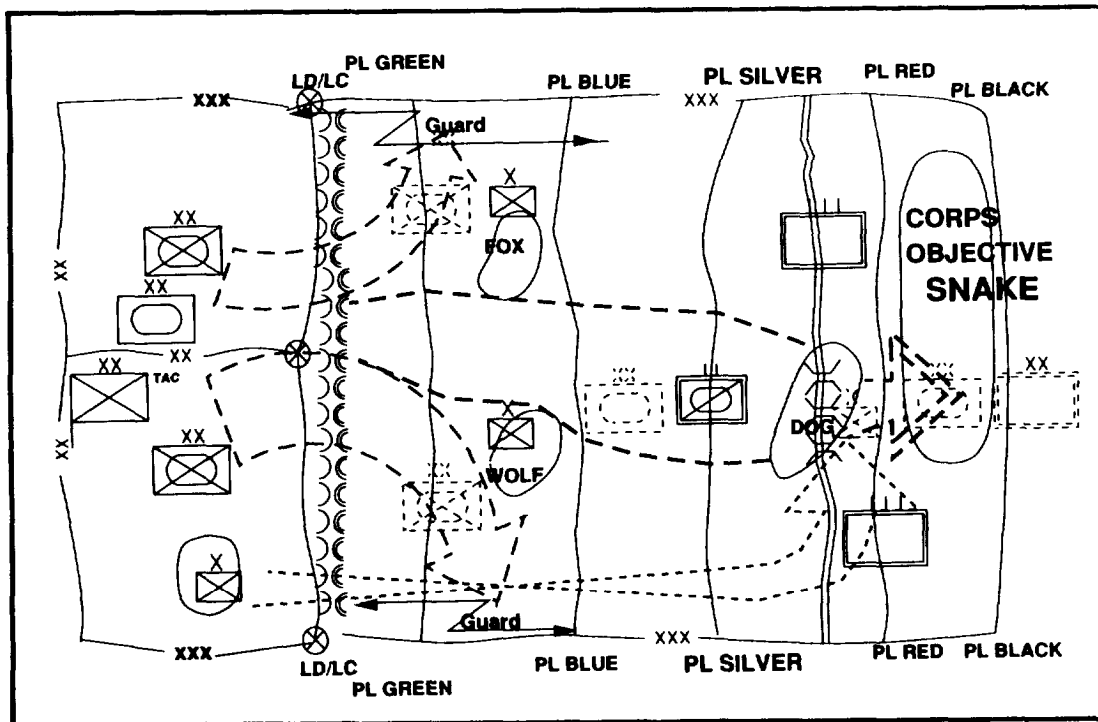

Figure 3-1. Corps concept of operation: the deliberate attack

crossing sites (objective DOG), penetrate enemy defenses with in-place defending mechanized divisions, and then attack with the corps reserve (an armored division) to seize objective SNAKE.

Following the attack of the armored division, the infantry division conducts consolidation and reorganization operations and prepares to follow and support the attacking armored division or conduct operations to secure the corps MSR from the line of departure/line of contact (LD/LC) to objective DOG.

The corps operation is planned and executed in five phases. In phase one, in-place divisions continue to defend, conduct aggressive patrolling, and counter reconnaissance operations. The infantry division moves forward to tactical assembly areas in preparation for the attack.

In phase two (Figure 3-2), the infantry brigades infiltrate across the forward edge of battle area (FEBA) to designated assault positions.

In phase three (Figure 3-3), in-place divisions attack to penetrate the FEBA and create a gap to pass the lead armored division for the attack on the corps objective. Simultaneously, dismounted

infantry attack to secure dominant terrain and choke points at objectives FOX and WOLF.

In phase four (Figure 3-4), the armored division attacks through the gap created in the FEBA by the in-place division, conducts linkup, and passes through choke points secured by the infantry. Once the armored division reaches PL BLUE, the third infantry brigade air assaults to seize river crossing sites on objective DOG.

In phase five (Figure 3-5), the armored division conducts a link-up operation with the dismounted infantry, conducts the river crossing, and then attacks to seize the corps objective. The infantry division may be directed to conduct follow and support operations to secure the lines of communication (LOC) from the FEBA to the corps objective.

Maneuver

The infantry division commander and staff receive the corps commander's concept. Through the decision-making process, they determine that a brigade is required to seize each objective. The commander's concept is to infiltrate two brigades

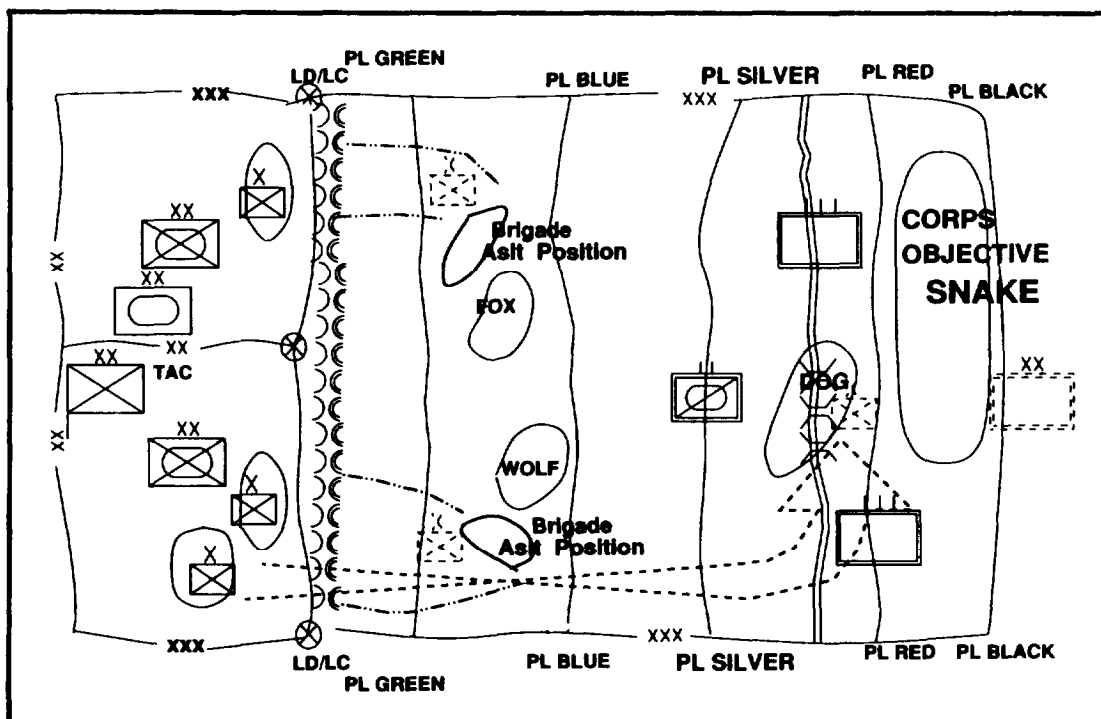

Figure 3-2. Corps concept of operation, phase two: the deliberate attack

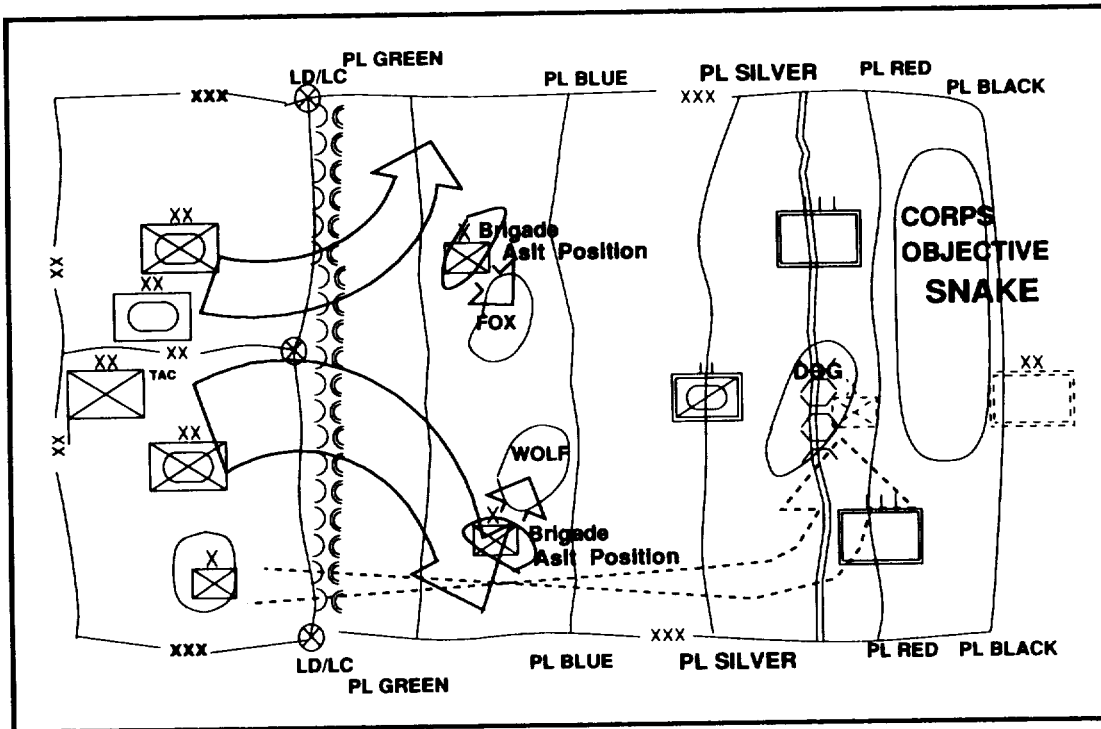

Figure 3-3. Corps concept of operation, phase three: the deliberate attack

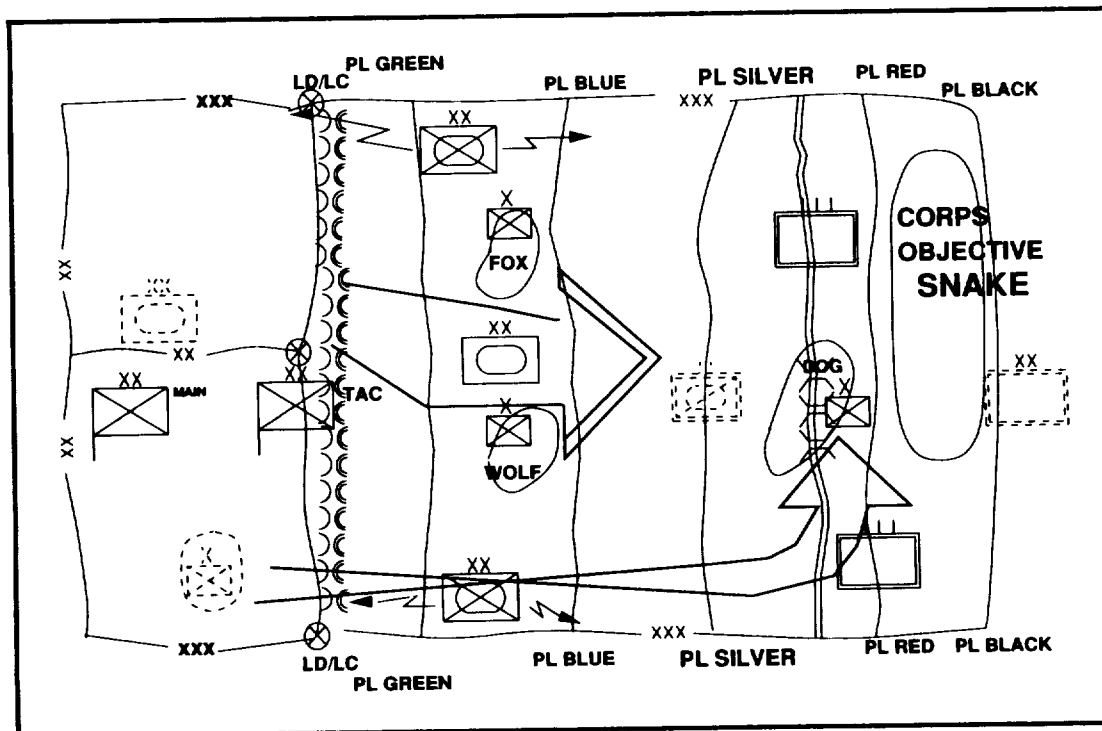

Figure 3-4. Corps concept of operation, phase four: the deliberate attack

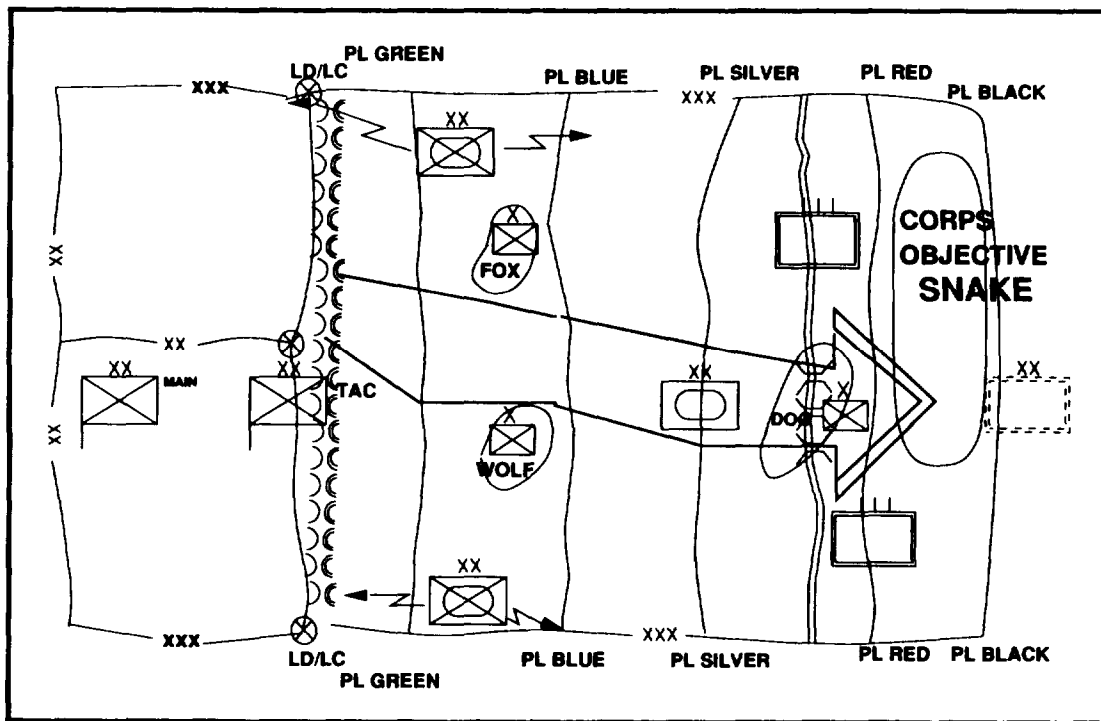

Figure 3-5. Corps concept of operation, phase five: the deliberate attack

to seize choke points, objectives FOX and WOLF, and a third brigade for an air assault operation to seize crossing sites at objective DOG. For C² reasons, one brigade will be attached to the division in the north. The commander task organizes his assets as shown, based on his concept and mission requirements (Figure 3-6). The brigade seizing

objective WOLF will initially be the division's main effort.

Deep Operations

The infantry division is part of the overall corps attack. In the conduct of this mission, it has no deep operation mission. Corps coordinates its

1st Bde	2d Bde	3d Bde	
Inf Bn	Inf Bn	Inf Bn	
Inf Bn	Inf Bn	Inf Bn	
Inf Bn	Inf Bn	Inf Bn	
FA Bn (105T) (DS)	FA Bn (105T)(DS)	FA Bn (105T) (DS)	
Engr Co (-) (Lt)	Engr Co (+) (Lt)	Engr Co (-) (Lt)	
ADA Btry (-)	ADA Btry (-)	ADA Btry (-)	
		IEW Tm	
DIVARTY	Avn Bde	DISCOM	Division Troops
Btry (155T) (GS)	Atk Bn	MSB	Recon Sqd (-)
FA Bde (R) DIVARTY	Aslt Hel Co (2)	FSB	MI Bn (-)
FA Bn (155SP) (R)	Aslt Hel Co/	FSB	ADA Bn (-)
FA Bn (155SP) (R)	xxx (OPCON)	FSB	Engr Bn (-)
FA Bn (MLRS) (GS)	Trk Co/xxx		MP Co
			Chem Co/xxx (GS)

Figure 3.6. Division task organization: the deliberate attack

deep operations with the infantry division to synchronize the infiltration and subsequent attack into the overall corps plan. Synchronization is accomplished by detailed planning and centralized execution by corps attack assets beyond PL GREEN. Corps directs its efforts toward shaping the battlefield to ensure the infiltration is not discovered early.

To accomplish this, corps uses other assets to disrupt, delay, deceive, and confuse the enemy. When the infantry division infiltrates, the corps may portray activity or possible threats at other portions of the battlefield to divert the enemy's attention from the infiltration area.

Close Operations

The infantry division commander's concept of the operation supports the corps commander's concept. Success depends on the division's ability to seize and hold its objectives and quickly pass the armored attack force through them. The infantry division commander knows the operation depends on achieving surprise and a coordinated attack by his brigades and the defending heavy

divisions. The commander's concept calls for a five-phase operation linked to the phases presented in the corps concept.

In phase one (Figure 3-7), the infantry division, with its reinforcing and augmenting elements, moves to forward assembly areas close to the LD/LC and begins reconnaissance and preparation for combat activities. It coordinates with defending divisions to position artillery and support units and identify passage points and possible infiltration corridors to attack positions. Support units move to base clusters near assembly areas. While the division is moving into assembly areas, the staff designates infiltration corridors large enough to accommodate a brigade infiltration (Figure 3-8).

The infantry division coordinates with the defending divisions for passage. Other essential information (fire support measures, ADA coverage, and engineer support) is coordinated and integrated with corps and the defending divisions to support the infiltration and subsequent attacks.

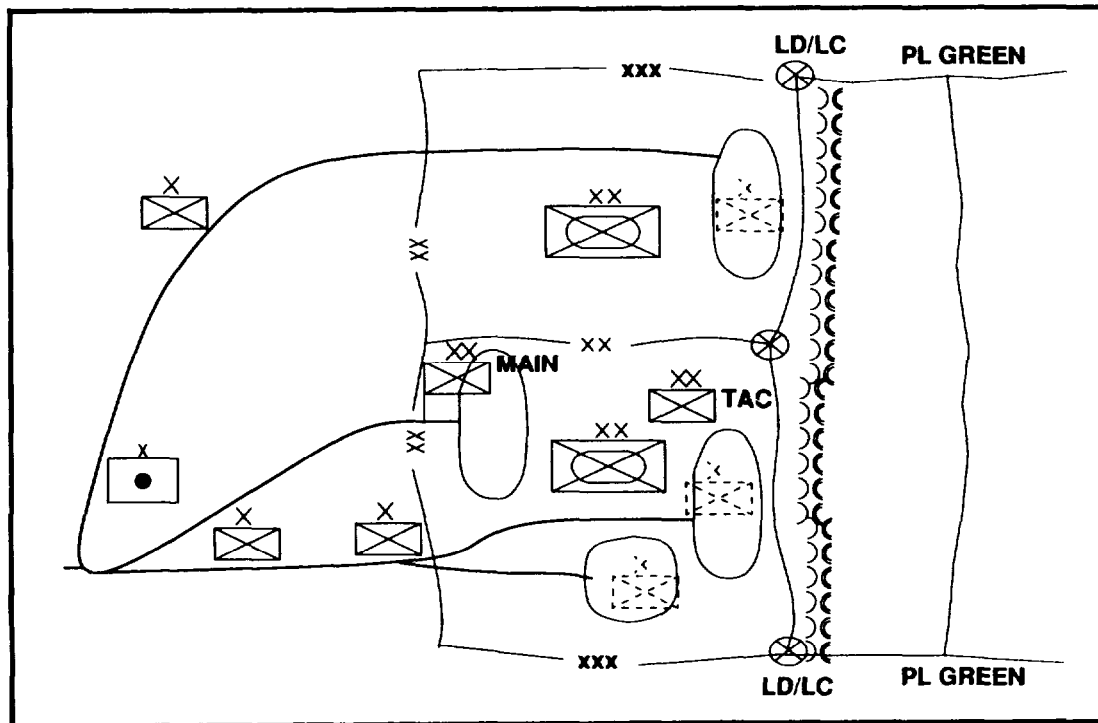

Figure 3-7. Division concept of operations: phase one

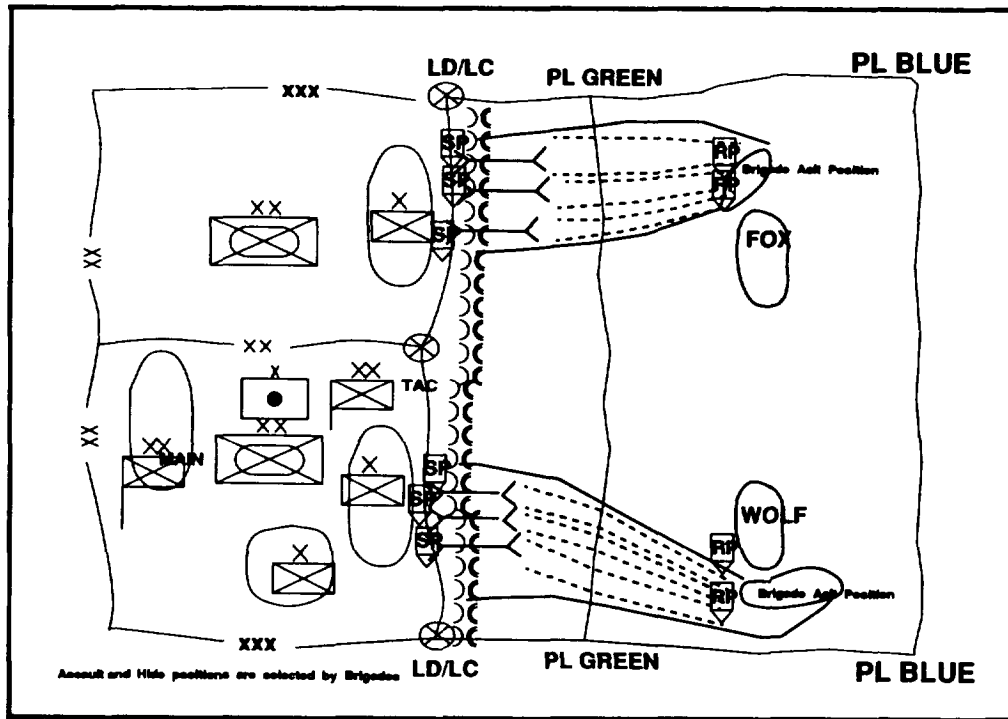

Figure 3-8. Division concept of operations: infiltration corridors

While in tactical assembly areas, the infantry brigades prepare for combat and conduct reconnaissance to confirm the viability of selected infiltration corridors. Brigades assign battalion corridors for reconnaissance. Battalions select routes inside assigned corridors. Brigades use this information to develop detailed infiltration routes. See Chapter 7 for more information on infiltration techniques.

In phase two, the 1st and 2d brigades conduct a passage of lines through in-place defending divisions and infiltrate through enemy areas to assault positions. As the brigades assemble for the infiltration and attack, boundaries are adjusted. Brigade rear boundaries are moved closer to the objective, thus establishing brigade boundaries around each objective. This meets the corps commander's guidance and provides the defending divisions room to maneuver as they transition to the attack. This maneuver room is necessary to create the penetration.

In phase three (Figure 3-9), the assault on objectives FOX and WOLF begins and the heavy

divisions attack simultaneously to penetrate and create the gap in the FEBA.

During phase four, the brigades consolidate on their objectives and link up with and pass the corps armored division. The infantry division has coordinated link-up procedures with the armored division prior to the attack. The brigade tasks battalions to establish link-up points at predetermined locations.

In phase five (Figure 3-10), the 3d brigade conducts the air assault to seize objective DOG while the lead unit of the attacking armored force simultaneously crosses phase line BLUE. The infantry brigade, which has seized objective DOG and the crossing sites, establishes link-up points to pass the armored division. It passes the division and prepares for the next mission (Figure 3-10 continued). Link-up points and procedures have been coordinated with the armored division prior to the attack.

Rear Operations

The primary role of the division rear and CSS elements is to coordinate logistics operations and

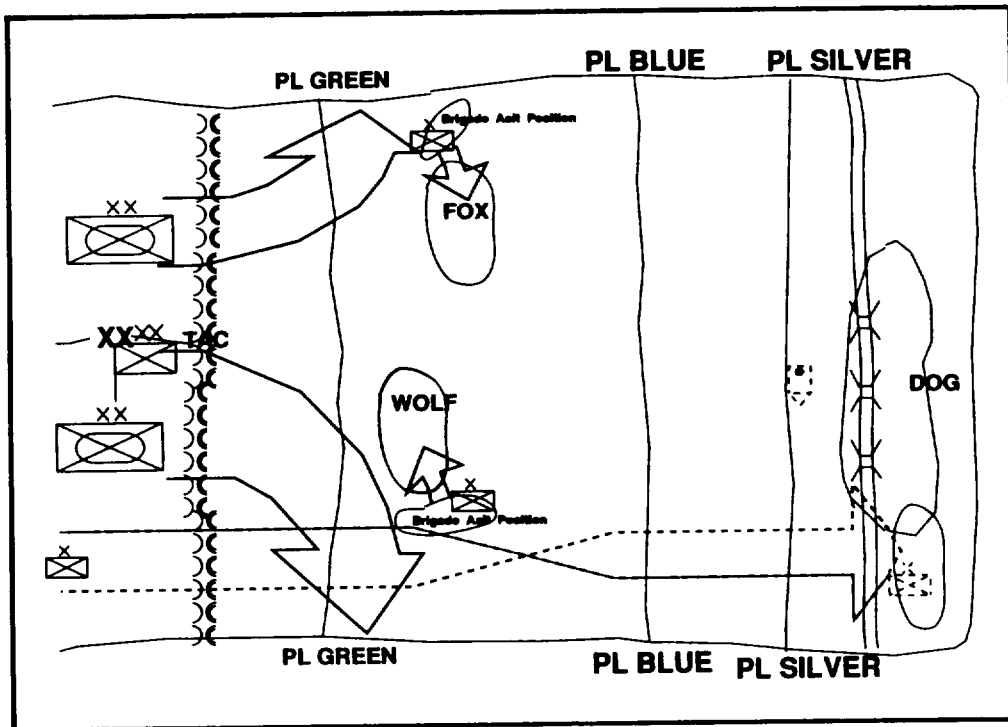

Figure 3-9. Division concept of operations: phase three

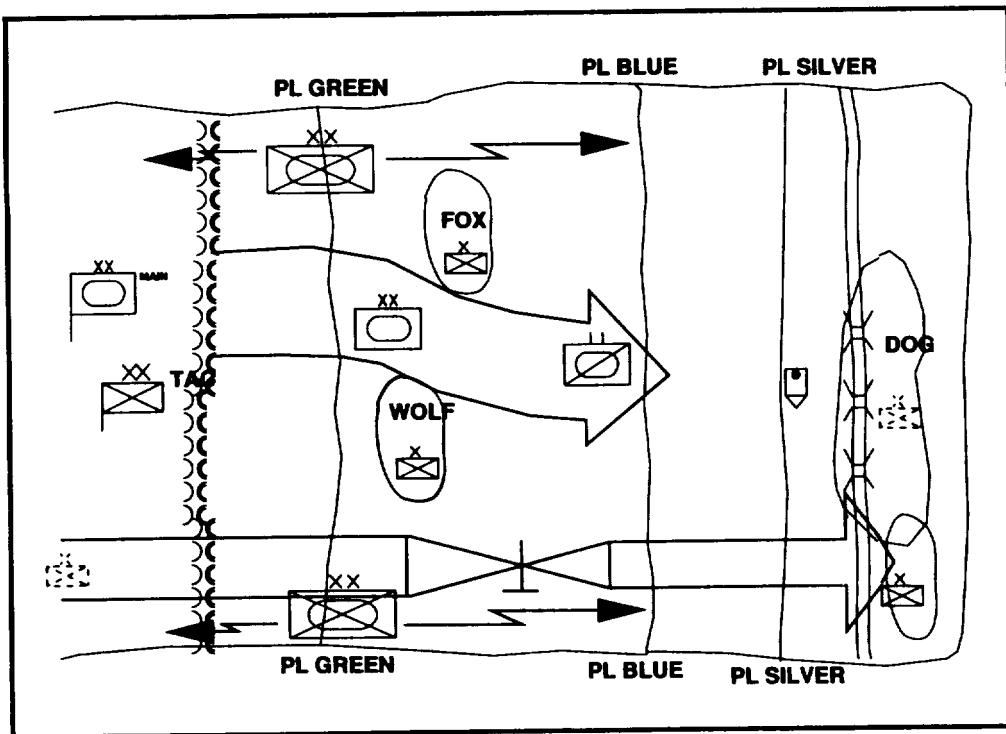

Figure 3-10. Division concept of operations: phase five

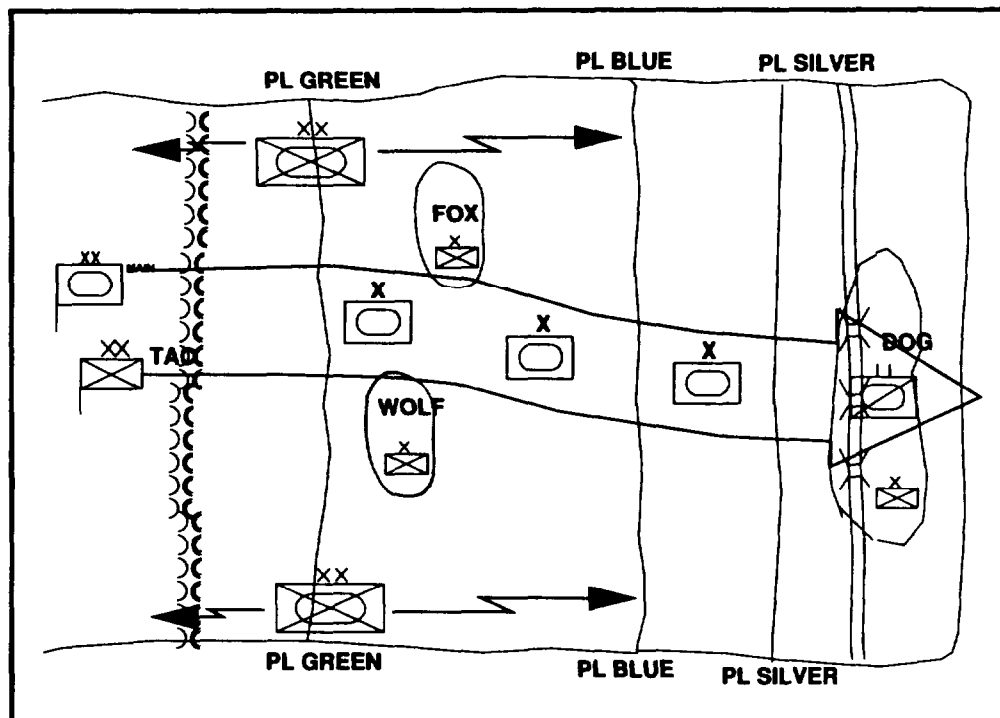

Figure 3-10. Division concept of operations: phase five (continued)

support for maneuver brigades. The rear CP and the defending mechanized divisions coordinate terrain management and traffic control. The divisions' rear CPs are responsible for coordinating rear area security.

Security Operations

The corps protects the infiltrating force by deception and active security. Before the infiltration begins, the corps attempts to deceive the enemy about the infantry division's movements and intent. It may do this by conducting feints and spoiling attack operations that divert enemy attention away from the infiltration area or by a corps deception plan. Once the infiltration begins, the infantry division coordinates security with the defending divisions and corps.

Reserve Operations

The division has no designated reserve during the infiltration movement.

Intelligence

The division commander, working with the G2, G3, and FSCoord, develops the PIR. The

intelligence assets required to collect PIR are integrated into the division collection plan. The division submits requests to corps for support and taskings to support the collection plan when the plan exceeds its organic capabilities. The commander's PIR focus on enemy units or actions which may adversely affect the infiltration, attack, or air assault operation and the location of all enemy ADA assets along the air assault flight route. The commander has decided his PIR are enemy maneuver locations and movements (company and larger), artillery, mortar, and sensor locations near objectives. The division coordinates with both the corps and defending mechanized divisions for previously collected information (enemy, sensor, or OP locations). The corps Quickfix and division LRSD are used to provide real-time information and intelligence. The LRSD teams are inserted via air about the same time as the infiltration starts. They report back on the status of LZs and crossing sites.

The division's MI assets support the division collection plan for all phases of the operation. In phases one through five, the infantry division uses maneuver brigades and those assets which

do not have to accompany infiltrating units to collect information. By positioning MI assets along the FEBA, they support both the division and corps collection plans. To facilitate collection of intelligence in phase five, an IEW team moves with the air assaulting brigade. The IEW team looks beyond objective DOG and is with the forward ground element.

Fire Support

The infantry division supports its attack with CAS, attack helicopters, artillery, and EW. Fires must be responsive during all phases of the operation. Task-organized division artillery and a corps reinforcing FA brigade provide responsive fire support.

Corps artillery assigns a priority of fire for each phase of the operation. During phase one, priority of fire is to the defending divisions; in phase two, the infantry division; in phase three, penetrating divisions; and in phases four and five, the attacking armored division.

The division FSE selects areas and coordinates with the G3 (or S3 at brigade level) before

positioning artillery in a unit's sector. The FSE then passes approved position areas to DIVARTY which positions GS and general support reinforcing (GSR) artillery. Brigade FSCOODs, in coordination with their maneuver commanders, position DS artillery. (Figure 3-11.) Artillery positions are well forward to provide continuous artillery coverage forward to support all phases of the infiltration operation—reconnaissance, infiltration, attack, and linkup.

Direct support artillery assets do not infiltrate with the brigades. However, the air assault brigade must take its DS artillery to provide counterfire support since counterfire targets will likely be out of the range of supporting artillery positioned behind the LD/LC.

The defending heavy divisions and corps artillery battalions are assigned nonstandard missions to allow them to fire in support of changing priorities. The nonstandard mission sets limits on ammunition expenditure and positioning. Ammunition to support the infiltration and penetration is stockpiled on the ground at battery locations. It is used to fire corps

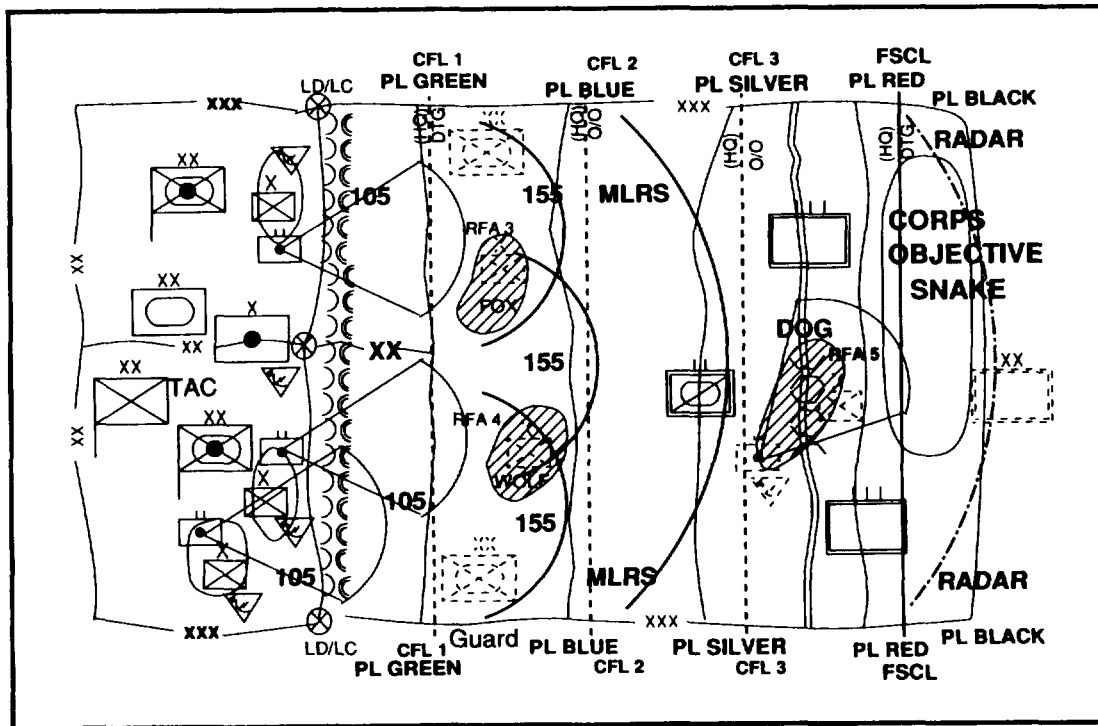

Figure 3-11. Division concept of operation: fire support

and division preparations, programs, target groups, and other types of fires. The corps artillery commander and his staff integrate fires to ensure efficient use of in-place and supporting corps artillery.

Coordination between the infantry division and corps FSE is critical to prevent fratricide. The infantry division establishes and coordinates fire support coordination measures for infiltration corridors, attack positions, objectives, and link-up points. The infantry division DIVARTY controls fire support between PL GREEN and PL BLUE during the infiltration. In-place divisions assume responsibility for fire coordination (within their boundaries to PL BLUE) once the infiltration is complete. The armored division assumes responsibility for controlling fires (beyond PL BLUE) when its lead element conducts the passage with the infantry. Corps establishes on-order restrictive fire areas (RFAs) around objectives and link-up points.

Engagement areas and family of scatterable mines (FASCAM) minefield are planned with corps to seal the objectives from possible enemy reinforcement and neutralize enemy actions to the flanks.

The corps artillery headquarters coordinates counter mortar and counterbattery radar positioning and control. The infantry division FSE coordinates radar coverages with the defending division's FSEs. Radars are positioned to provide continuous support throughout the infantry division's sector. Corps establishes Quickfire channels between radars and firing units to rapidly silence enemy indirect fire systems which may affect the corps plan. A Q-36 radar with the 3d brigade's DS artillery provides counterbattery coverage at the river crossing sites.

Mobility and Survivability

Priority of engineer support within the infantry division is mobility. Light engineer companies are attached to each brigade (See task organization at Figure 3-6.)

During the infiltration light engineer companies support the crossing of obstacles and report information on obstacles, bridge conditions,

and soil composition in the areas they infiltrate. The infantry division, defending divisions, and corps use this data to prepare for the penetration, attack, and follow-on movement of CSS assets. Armor division engineers support the crossing of the LD/LC by the infantry division. Infantry division light engineer companies with brigades breach obstacles during the assault on objectives and, where possible, in and around the link-up points. The infantry division engineer plans FASCAM to block enemy counterattacks and reinforcements. The infantry division's engineer battalion retains personnel and equipment not infiltrated near the LD/LC to support on-order follow and support missions.

Air Defense Artillery

The division ADA's primary role is to provide AD coverage during all phases of the plan. For the infiltration, infantry brigades move with only man-portable air defense (MANPAD) systems. Vulcans and Avengers are left in the rear near the LD/LC. They provide coverage for the division CP and CSS assets. Stinger weapons systems provide coverage during the passage of the infantry division, the infiltration, and the attack, and at link-up points. This allows ADA systems of attacking divisions to move forward under the coverage of the infantry division systems.

During the infiltration, corps ADA priority is to infiltrating brigades. Corps pushes its high altitude ADA coverage as far forward as possible to support the operation. Division ADA weapons are under "weapons hold" during the infiltration. Passive defensive measures are the division's primary air defense. Air defense elements with infiltrating brigades form a protective umbrella around and over objective areas. They maintain this coverage and extend it to cover link-up points once objectives are secure. On execution of the air assault, the corps AD priority shifts to the attacking divisions. Air defense systems in the air assault brigade establish coverage for the assault and river crossing sites. The infantry division's G3 directs division towed systems forward with the attacking heavy division as soon as possible. This strengthens coverage over choke points and river crossing sites and provides additional ground firepower if required.

Combat Service Support

Brigades can sustain field operations for 48 to 72 hours without resupply. The division commander has determined resupply of class I, IV, and V, and evacuation of wounded, will be required on consolidation on objectives (Figure 3-12). The main effort is weighted with CSS assets, particularly HSS. Maximum use of the container delivery system (CDS) is coordinated by G4 to conduct resupply. Preconfigured class VIII packages, tailored to meet specific mission requirements, are shipped via push-packages to HSS elements.

Aerial assets accomplish resupply during the consolidation on the objective. Movement of FSB support assets is integrated into the attacking division's follow-on logistics movement. The division's DTO coordinates MSR to locations selected by the forward brigades. FSBs move forward on order from their supported brigade. Information on requirements and displacements is provided to the DISCOM.

The infantry division DISCOM HQ may not move during this operation. Main support bat-

alion units and elements of the materiel management center (MMC) move to the vicinity of the FSBs to support reorganization of the brigades in preparation for the next mission.

Command and Control

On receipt of the warning order, the infantry division TAC CP moves forward to coordinate the infiltration with defending divisions. The TAC CP determines brigade assembly areas, initial passage points, corridors, and link-up points as brigades prepare to move to assembly areas. In this example, the TAC CP is forward near the LD/LC to support brigade operations. To aid C², the infantry division provides liaison teams to each defending division. The infantry division uses control measures established by corps for coordination. It establishes brigade boundaries and responsibilities for each phase of the infantry division operation. Brigade CPs move forward and collocate with the CPs of brigades through which they will pass, as do their battalions.

The infantry division TAC CP moves forward behind the last maneuver brigade of the attacking armored division with the reconnaissance

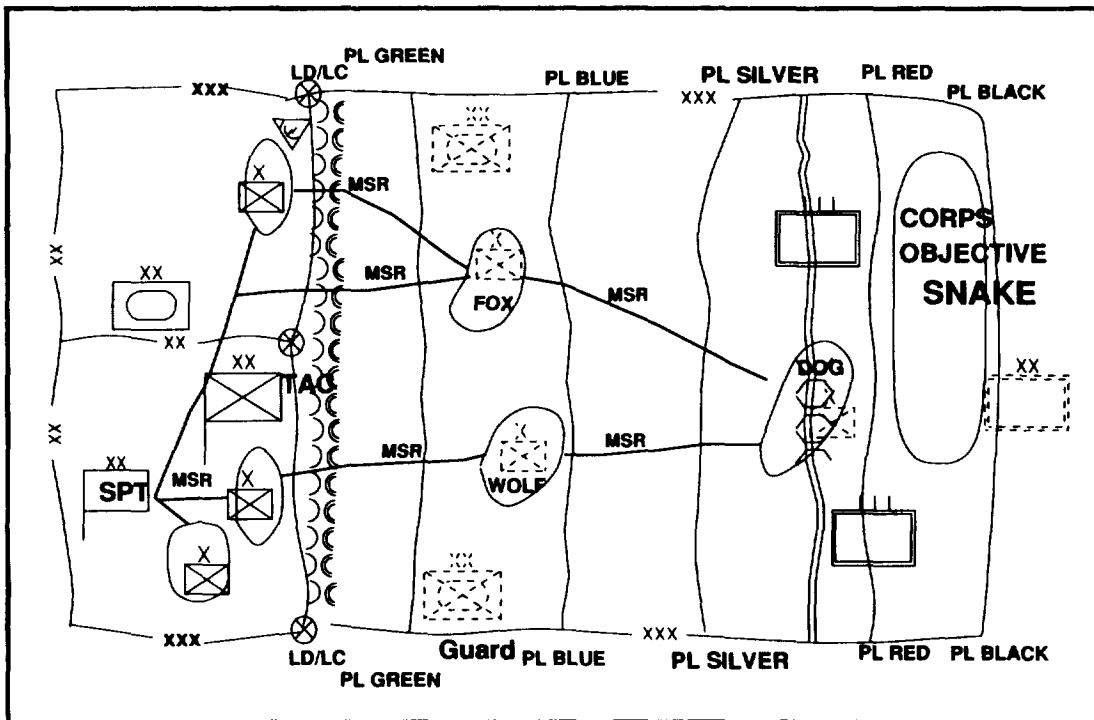

Figure 3.12. Division concept of operations: combat service support

squadron ground troop; this provides security to the TAC while it moves. The TAC CP repositions forward in the vicinity of objective DOG. The command section air assaults with the 3d brigade as the river crossing sites are secured. Main and rear CPs move on order.

Divisions equipped with a lightweight tactical fire direction system (LTACFIRE) may use burst transmissions for communications during the infiltration. This reduces radio transmission time and provides additional security.

PENETRATION

Penetrations are used when enemy flanks are not assailable and no other form of maneuver is permitted. This is the least desirable form of maneuver performed by light divisions. Since it pits the attacker's strength against the defender's, penetration may result in higher casualty rates than other forms of maneuver.

The penetrating unit masses sufficient combat power at the points of penetration to overwhelm the enemy. The infantry division masses effects from fires of all available means to breach enemy defensive positions along a narrow front, hold open the shoulder, and degrade the effects of a counterattack. Follow-on friendly forces rapidly exploit success of the penetrating forces. Multiple penetration points may be desirable for the attacker if it causes the enemy to disperse his fires and consider multiple threats before committing.

In this example, the corps has conducted a successful offensive operation that has defeated the enemy's main and secondary defensive positions forcing the enemy to withdraw. The corps, approaching its culmination point, has halted further exploitation operations and has ordered its divisions to establish hasty defensive positions. This operational halt provides the corps time to reposition resources and forces in preparation of renewing the offensive.

Enemy forces, significantly weakened by the corps' initial success, are attempting to reestablish their defensive positions. Taking advantage of the corps' temporary halt, the enemy anchors its defense on restrictive terrain which dominates the armored approaches within the advancing corps sector. Except for these few roads, terrain within the corps sector is generally inaccessible to

armored forces. Remaining enemy forces are positioned loosely across the frontage, forming a screen line to locate friendly infiltrations. Enemy locations are generally known and the corps covering force is maintaining contact with the enemy.

The corps commander continues the offensive as soon as possible, maintaining pressure on the enemy and allowing him little time to strengthen his defenses with reinforcements. The commander maintains a corps defensive frontage with two divisions in hasty defensive positions that are tied into the adjacent corps on the right flank. The operational pause allowed the corps time to consolidate and prepare for a penetration attack in the corps eastern sector.

As the corps main effort, the light division has the mission to conduct the penetration, given the restricted terrain; the western division conducts a feint as a supporting attack to confuse and hold repositioning of forces by the enemy. The corps attack is synchronized with the adjacent corps attack, presenting the enemy with multiple threats across a wide frontage and preventing him from consolidating fires. An artillery preparation phase precedes the corps attack to weaken the defender, limiting his ability to react against the penetrating force, and to cover the light division movement. Once the light division makes the penetration, the follow-on armor division exploits it and continues the attack. The remaining corps' divisions roll up the enemy flanks and conduct follow and support missions behind the exploiting armored division. The corps orchestrates deep operations during the penetration. This rapidly executed operation quickly defeats the weakened enemy before he can reinforce his defense, thus denying him defensible terrain.

Maneuver

The division commander moves through the emplaced friendly defending division to conduct a coordinated night attack to secure selected objectives as the corps penetration force. Taking advantage of limited visible and restricted terrain, the division commander conducts the penetration with two brigades at two separate points. The eastern penetration point is the division's main attack. (See Figure 3-13, page 3-14, and Figure 3-14, page 3-15.)

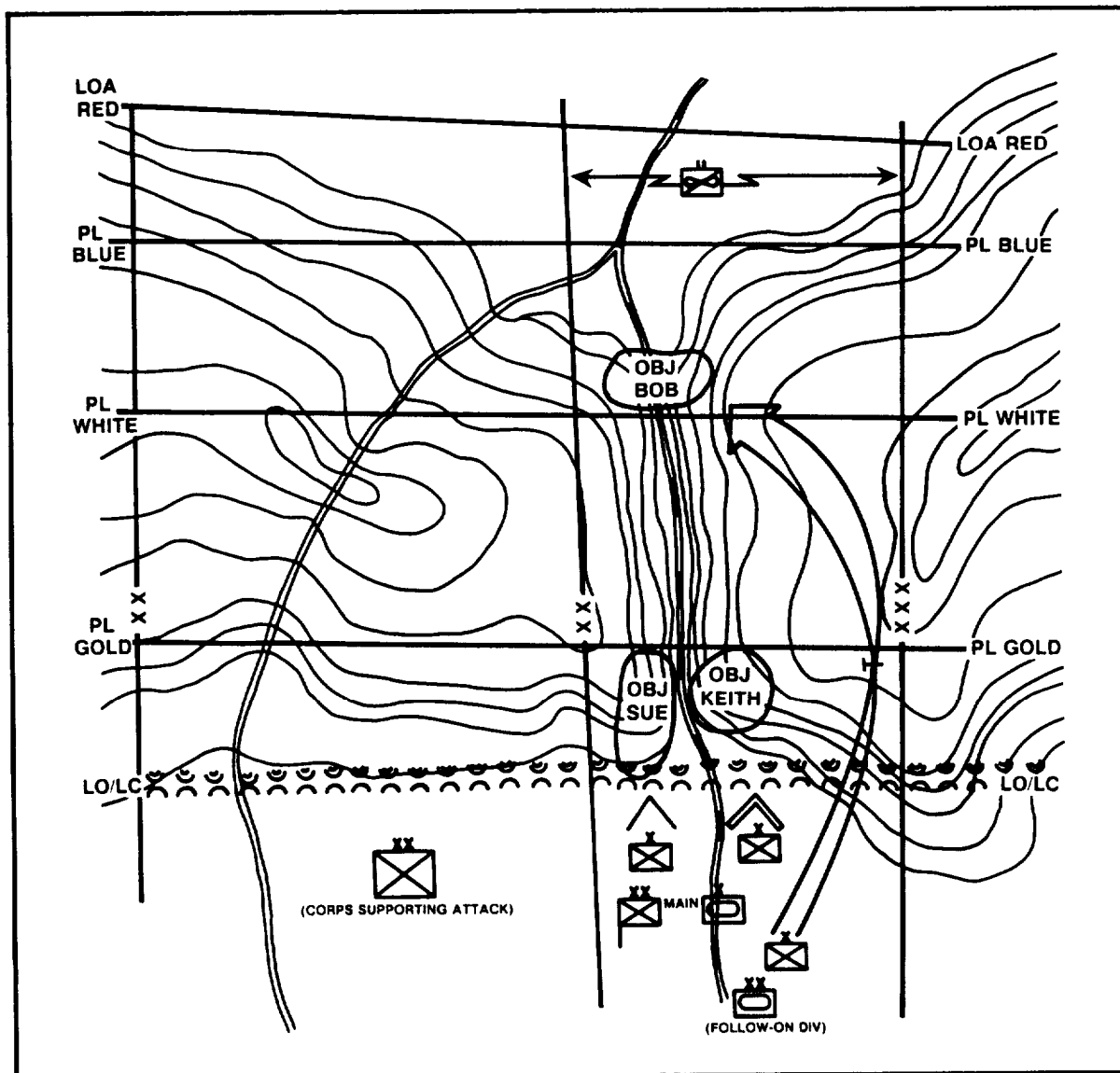

Figure 3-13. Concept of operation

An intense artillery preparation precedes the penetration attack to cover the division's movement, soften the enemy's defenses at the penetration points, and close the area to enemy reinforcements during the attack. On order, a brigade (-) air assaults to secure blocking position forward of the penetration attack to prevent enemy reinforcements. Once the initial penetration is made, the attached armored brigade (OPCON) moves rapidly through the created rupture, clearing the road and executing a linkup with the brigade (-) occupying forward

blocking positions. The division commander intends to maintain a battalion-sized reserve capable of influencing the penetration and or committing to secure flanks, if required. Success is the penetration of the enemy's defense, facilitating movement of the follow-on corps forces through the division's assigned sector.

Deep operations for the division are fought by the corps. Close coordination between the division and corps staffs synchronizes the corps deep operations with the division's penetration. The

<i>1st Bde</i>	<i>2d Bde</i>	<i>3d Bde (-)</i>	<i>Armd Bde (OPCON)</i>
Inf Bn	Inf Bn	Inf Bn	Inf Bn (Mech)
Inf Bn	Inf Bn	Inf Bn	Armd Bn
Inf Bn	Inf Bn	FA Bn (105T) (DS)	Armd Bn
FA Bn (105T) (DS)	FA Bn (105T) (DS)	Engr Co (Lt)	FA Bn (155 SP) (DS)
Engr Co (Lt)	Engr Co (Lt)	ADA Btry (-)	Engr Co (M) (DS)
ADA Btry (-)	ADA Btry (-)	IEW (DS)	Engr Co (M) (DS)
FSB	FSB	FSB	ADA Btry (-) (DS)
	FSB		
<i>Avn Bde</i>	<i>DIVARTY</i>	<i>DISCOM</i>	<i>Division Troops</i>
Atk Bn	Btry (155) (GS)	MSB	Inf Bn (Reserve)
Aslt Hel Co	FA Bde	Trk Co	MI Bn (-)
Aslt Hel Co	FA Bn (155 SP)		ADA Bn (-)
Cavalry Sqd	FA Bn (155 SP)		Engr Bn (-) Lt
	FA Bn (MLRS)		Engr Bn (-) (Mech)
			MP Co
			Chem Co/xxx (GS)

Figure 3-14. Task organization

division commits its assets and efforts to the penetration.

The division attacks under the cover of darkness and the corps' artillery preparation. On order, the division conducts a coordinated attack with two brigades attacking to seize their designated division objectives. Seizure of these two objectives provides flank security for the exploiting armored brigade. The 3d brigade (-), which is held to weight the initial penetration if required, on order conducts an air assault to establish blocking positions forward of the penetrating brigades to prevent enemy reinforcing forces from entering or influencing the penetration. On seizing the objectives, the attached armored brigade attacks to clear a route through the enemy's defenses for the corps follow-on forces. The armored brigade conducts a linkup with the air assault brigade and establishes a hasty defense that strengthens the division's forward defense in advance of corps follow-on forces. On order, the division passes the corps' follow-on divisions through sector.

The aviation brigade supports 3d brigade's air assault, establishing a frontal screen forward of 3d brigade on executing the air assault. The screen provides early warning for the division and delays enemy reinforcements from entering the

penetration. The division cavalry is attached to the aviation brigade during this operation.

Intelligence

The commander develops his PIR to pinpoint enemy positions and movement of maneuver, artillery, mortars, and sensor locations. The division coordinates with both the forward defending friendly division and corps for additional collection support. LRSD teams and corps Quickfix assets provide real-time intelligence before and during the penetration. Division intelligence assets are positioned along the FEBA except for the LRSD and IEW teams attached to the air assault brigade.

Fire Support

As the corps main effort, the division receives additional corps fire support. The corps allocates a FA brigade to support the division's penetration and coordinates the defending division fires to ensure massing of fires in the vicinity of the penetration point. All artillery units available support the penetration except for the western division artillery conducting the corps feint.

Each infantry brigade retains its DS artillery battalion. The air assault brigade takes its DS artillery battalion to provide fires and counterfires support.

Mobility and Survivability

Priority of the engineer efforts is initially to mobility. Engineer assets assist in the breaching and forward momentum of the exploiting armored brigade. Each penetrating brigade receives an engineer company to assist in its initial breach. These light engineer companies assist in eliminating obstacles during the assault. The noncommitted personnel and equipment of the light engineer battalion are positioned near the LD/LC to support the penetration and follow-on forces when required. A mechanized engineer battalion is attached to the armored brigade to clear the road network as the brigade attacks. The air assault brigade engineer company assists in establishing countermobility obstacles to block enemy reinforcements. As heavy equipment arrives and countermobility efforts are completed, survivability positions become priority for the blocking brigade. The infantry division engineer battalion plans FASCAM to block enemy counterattacks and reinforcements during this operation.

Air Defense

Air defense's primary role is to provide the division defense coverage during the penetration and follow-on operations. Avengers and Vulcans are located near the LD/LC. Coverage by the forward defending division ADA is integrated into the attacking division coverage. Attached brigade Stinger teams provide coverage to the penetrating and air assault forces and attached Avengers provide coverage for the exploiting armored brigade. With organic and corps-coordinated coverage, the division has ADA coverage throughout this operation.

Command and Control

The TAC CP moves forward to coordinate the passage of the division's attacking forces on receipt of the corps warning order. The TAC CP coordinates passage lanes, attack positions, collocation of CPs, supporting fires, and placement locations for supporting division assets. The TAC CP remains near the LD/LC until the brigade objectives are seized and then moves forward with the attacking armored brigade. The TAC CP will be established in the vicinity of the blocking brigade once linkup with the armored brigade is

complete. The main and rear CPs remain in the division's assembly areas initially, then displace on order with follow-on forces.

MOVEMENT TO CONTACT

The division conducts a movement to contact to gain or regain contact with the enemy and in a way that risks the smallest possible part of the force. This keeps the remainder available to respond immediately when the division makes contact. When executed against a force of comparable mobility in restrictive terrain, movement to contact is viable for the infantry division. Once the enemy is found, the ability to move rapidly to conduct hasty attacks or mass additional combat power is the key to success. Movement to contact operations include the approach march, search and attack, and reconnaissance in force.

The Approach March

In this example, the corps has been successful in driving back enemy forces from their initial lines of defense. Contact with the enemy has been lost as the enemy has withdrawn. (Figure 3-15). The nature of the terrain causes the corps commander to use his infantry division in a movement to contact to reestablish contact with the enemy. If successful, the corps commander will commit his armored force. The corps commander's intent is to regain contact with the enemy and exploit success. The current tactical situation and intelligence reports indicate:

- The enemy's location is unknown.
- Corps has no covering force.
- The enemy has the capability to disrupt or delay the corps.

Ž US forces have air superiority.

Ž The corps heavy division is in a hasty defensive and has an on order mission to continue the attack.

Ž Terrain is restrictive with limited movement routes for armored forces.

Maneuver

The division commander's concept of operations requires aggressive and deliberate movement over restrictive terrain. The division will

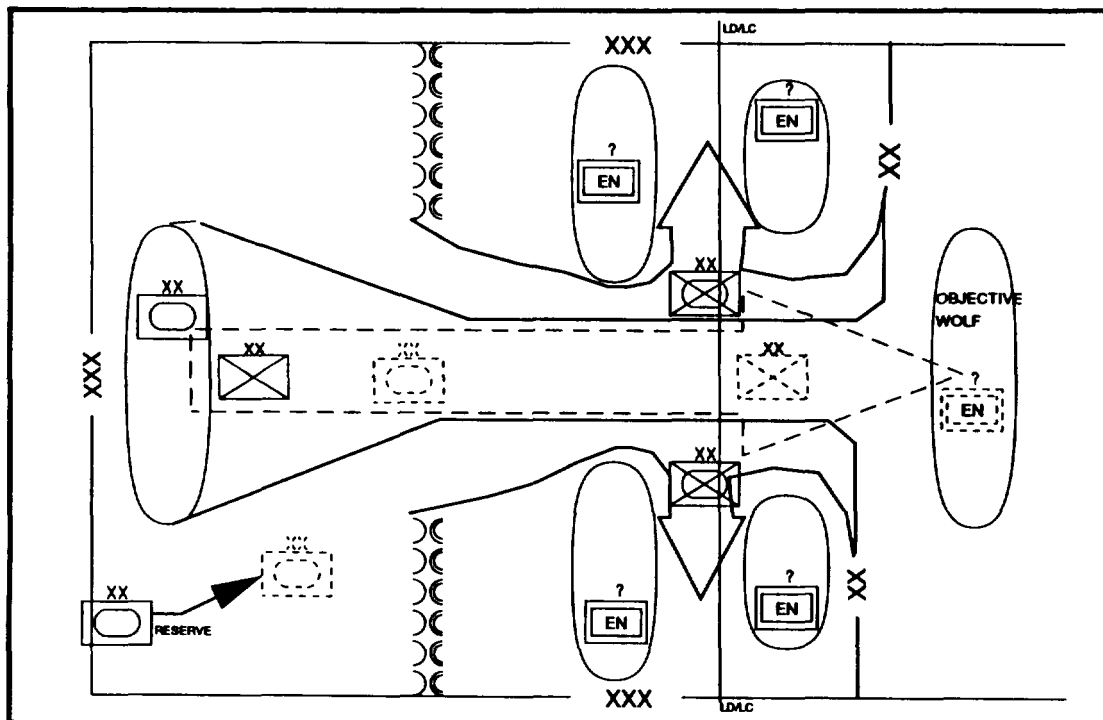

Figure 3.15. The movement to contact: corps concept

conduct an approach march, crossing the LD/LC in brigade column to locate and establish contact with the enemy. Once the division makes contact, it will develop the situation. The division has the option to destroy or contain the enemy, depending on the size of the enemy force and the situation at the time of contact. If the division does not make significant contact, it continues to move until it traverses the restrictive terrain at phase line GREEN (Figure 3-16, page 3-18) and armored forces pass forward.

Deep Operations. The corps conducts deep operations against uncommitted enemy forces and lines of communications and supply of those forces. It provides the division with intelligence on these uncommitted forces.

Close Operations. While the division conducts a movement to contact to gain or regain contact with the enemy, it must do it in a way that risks the smallest possible part of the force while the remainder is available to respond when the lead element makes contact with the enemy.

In this example, the division's approach march is task-organized and moves in brigade column along one axis. (See Figure 3-17, page 3-18.) The cavalry squadron conducts a zone reconnaissance in front of the brigades to locate enemy forces.

A battalion task force constitutes an advance guard force which moves to the front of the lead brigade. The lead brigade (-) follows the advance guard while the other two brigades follow in trail. Elements from the trail brigade form a rear guard. Flank security is provided by the brigades and a screen is established on their flanks. Combat support and limited CSS assets are integrated into brigade columns.

The division cavalry squadron locates the enemy, develops the situation within its capability, and maintains contact until the advance guard is committed. If the division commander decides to conduct a hasty attack, the lead brigade is in position to do so. If the enemy force is of sufficient size to preclude an attack by one brigade, the lead brigade may fix the enemy force as the

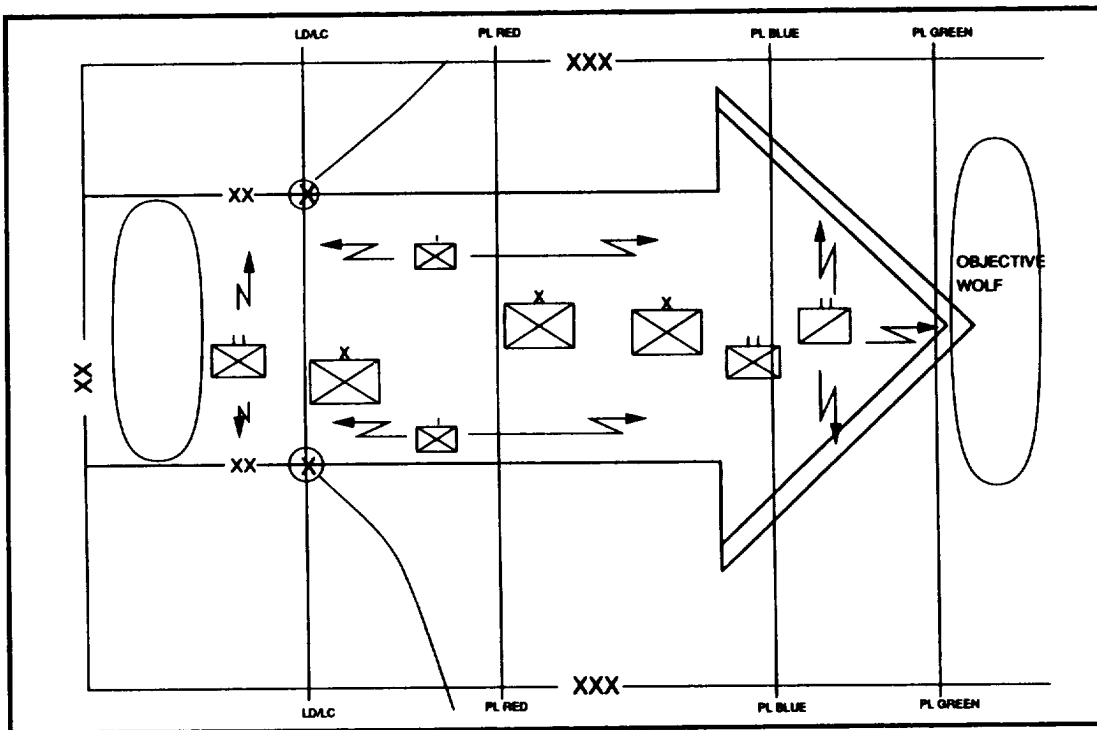

Figure 3-16. The approach march: maneuver

1st Bde	2d Bde	3d Bde	
Inf Bn	Inf Bn	Inf Bn	
Inf Bn	Inf Bn	Inf Bn	
Inf Bn	Inf Bn	Inf Bn	
FA Bn (105T) (DS)	FA Bn (105T) (DS)	FA Bn (105T) (DS)	
MI Plt	MI Plt	MI Plt	
Engr Co (+) (Lt)	Engr Co (-) (Lt)	Engr Co (-) (Lt)	
ADA Btry (-)	ADA Btry (-)	ADA Btry (-)	
FSB	FSB	FSB	
DIVARTY	Avn Bde	DISCOM	Division Troops
Btry (155T) (GS)	Atk Bn	MSB	Recon Sqd (-)
FA Bde (R) DIVARTY	Aslt Hel Co (2)		MI Bn (-)
FA Bn (155SP) (R)			ADA Bn (-)
FA Bn (155SP) (R)			Engr Bn (-)
FA Bn (MLRS)			MP Co

Figure 3-17. The approach march: task organization

second brigade in column swings to the flank to attack the enemy.

Rear Operations. Rear units, DISCOM, and division troops remain in the DSA. The in-place unit provides security until committed. The rear CP will coordinate and synchronize both air and ground movements forward. Sustainment units

move on order once the restrictive terrain is secured.

Security Operations. In addition to the advance, flank, and rear guards, the division maintains security by positioning its assets within mutually supporting distances as it moves. Early warning is critical to its security.

Long-range surveillance (LRS) patrols and electronic intelligence gathering assets help locate the enemy and indicate his possible locations and intent.

Reserve Operation. There is no dedicated reserve for this operation. The reserve mission is given to the least committed brigade in the event of contact.

Intelligence

The primary mission of intelligence assets is to find the enemy and report to the commander in a timely manner. The commander establishes his critical information requirements (CIR) early to focus the efforts of all collection assets. The commander approves a collection plan and specific PIR, the acquisition asset to use, and actions to take once PIR are reported. For more information on this process, see Chapter 5.

The division requires intelligence information continuously as it moves forward. The cavalry squadron reports directly to the TAC CP where the intelligence staff officer analyzes the information along with other sources, such as division and corps long-range surveillance units. Collection of information from designated NAIs and TAIs also aids the development of intelligence to locate the enemy.

Intelligence acquisition gaps may occur. Due to the area covered by the division, the G2 must plan for possible gaps and have a means to ensure the enemy is not hidden, awaiting the division passage. In this example, the G2 has employed MI assets in layers to see the battlefield with electronic detection equipment. Maneuver units accomplish forward and flank information gathering. If maneuver units find enemy concentrations and if the decision has not already been made in the targeting process, the commander will have to decide whether to attack or assume a hasty defense. The MI battalion moves its assets as directed by the G2 in coordination with the G3.

Fire Support

Primary fire support considerations in a movement to contact include anticipating enemy actions during the movement, task organizing for combat, and moving artillery battalions forward.

Also important is the ability to provide rapid and accurate fires on targets which affect the survivability and mission of the force.

In this example (Figure 3-18, page 3-20), the division commander has integrated fire support into the total mission. A Quickfire channel is established to improve fire support to the aviation brigade and cavalry squadron. The task organization provides flexibility, responsiveness, and agility whenever and wherever the division makes contact with the enemy.

As the division moves across the LD/LC, DS and GS artillery will be in position to support. Once maneuver brigades have determined routes to move the artillery, batteries and battalions move on order by echelon. Since artillery follows its brigade, movement control is maintained at brigade level except for the GS battery. This battery moves once the FSE coordinates land in sector and passes the approved position to DIVARTY who positions the battery. The division commander uses the battery with the aviation brigade to provide additional fire support rapidly as needed on the battlefield.

During the movement, maneuver elements are extremely vulnerable to enemy indirect fires. If possible, corps augments the division with the capability to plan, execute, and coordinate effective counterbattery and counterfire programs. In this example, a corps MLRS battalion has been given the mission to reinforce the DIVARTY and provide the required coverage from the LD/LC. Corps has also provided associated Q-36 and Q-37 radars electronically linked to the MLRS battalion to destroy any enemy artillery units which fire in the division AO. Artillery units will carry maximum amounts of ammunition but will still require resupply.

As maneuver units move forward, fire support control measures ensure rapid coordination of fire support assets and preclude delays in firing in areas already passed. The DIVARTY headquarters is located near the LD/LC. From this position, it maintains C² and sustainment requirements for the division artillery. The DIVARTY repositions forward as required to maintain the capability to coordinate fires.

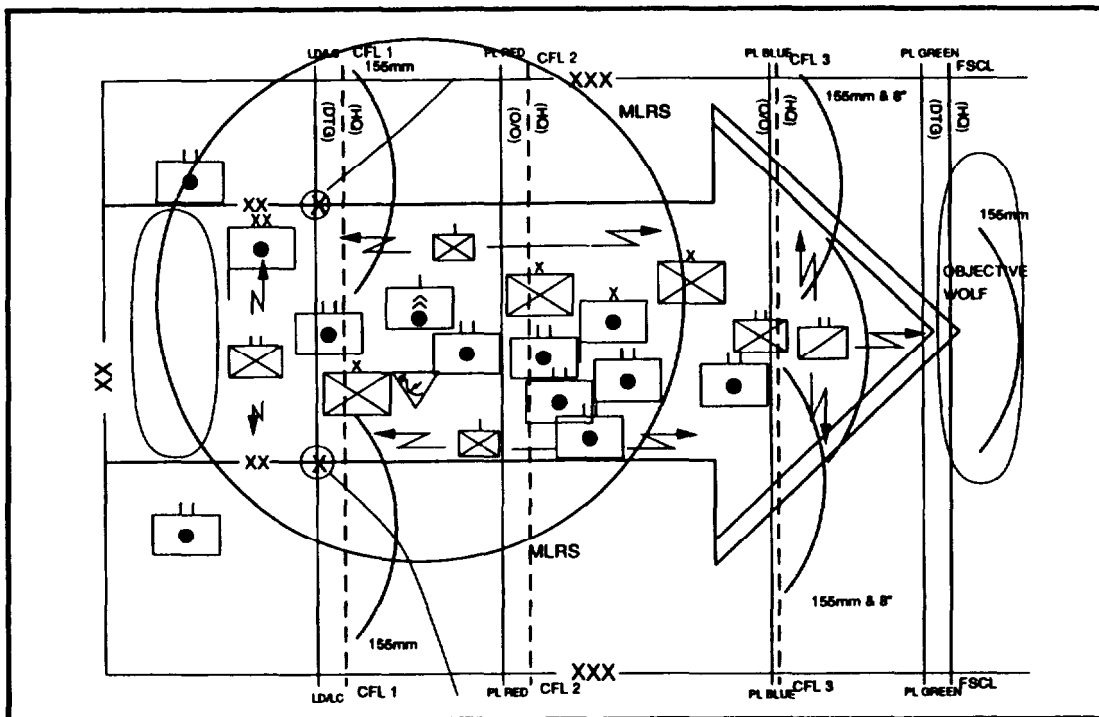

Figure 3.18. The approach march: fire support

Mobility and Survivability

The primary engineer mission is to locate and breach enemy obstacles to facilitate mobility of CSS elements and the corps follow-on force.

Division engineer companies are task-organized to each brigade and the cavalry squadron. Engineers with the cavalry squadron identify obstacles and report conditions of routes. They provide limited capability to breach obstacles.

Engineers with brigades identify obstacles and report route conditions along routes of march and to the flanks. If required, engineers on the flanks can construct situational obstacles to stop possible enemy penetrations from the flank. Engineers coordinate with the division FSE to emplace FASCAM. The engineer battalion headquarters coordinates support to forward engineer companies to expedite division movement.

Air Defense Artillery

The infantry division has limited ADA assets. Resources identified as critical to the division have priority for ADA coverage. Stinger teams are in DS to brigades. For the movement, towed

Vulcans and or Avengers are kept under the control of the ADA battalion. The division requests additional ADA support it needs from corps.

In this example, the ADA battalion has been tasked to protect key elements and resources of the division. Air defense assets are moved based on mission requirements and the developing enemy threat. Maneuver brigades use passive ADA protection to conceal themselves from the enemy threat. Corps assets provide ADA protection for the rear area.

Combat Service Support

The division is task-organized for speed and stealth. Units carry a 48-hour LOGPAC (class I, III, & V). In this example (Figure 3-19), limited CSS assets are pushed forward with brigades, and remaining elements are under the control of the DISCOM. This ensures limited logistics support is with the brigades. The FSBs move forward by wheeled vehicle.

The DISCOM and the rear CP work together to coordinate limited wheeled vehicle routes in the division area between the corps force and division resupply requirements. The DISCOM and

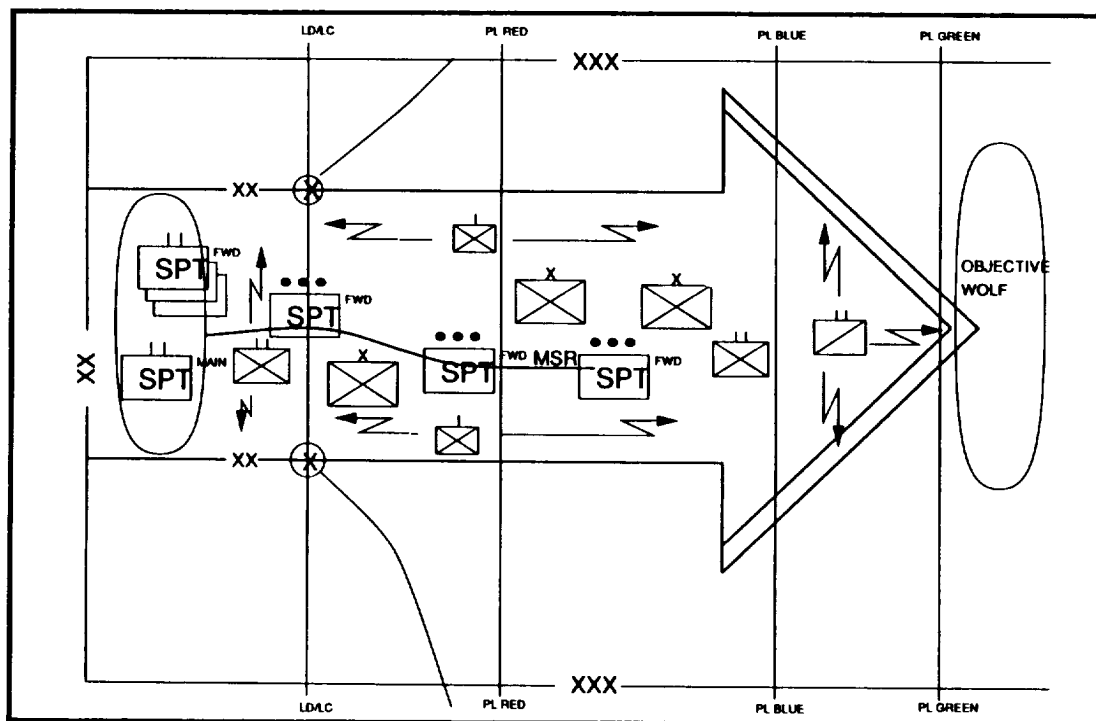

Figure 3-19. The approach march: CSS

the rear CP displace on order when the corps force has passed through the division and when MSRs are secure.

Command and Control

Brigades are task-organized into self-contained task forces to enhance flexibility and the ability to attack enemy forces as they locate them.

The division TAC CP moves behind the lead brigade and maintains communications with the cavalry squadron. The division main CP stays at the LD/LC until the division secures the restrictive terrain and the corps heavy division passes through. The rear CP maintains a position in the rear behind the main CP. The command group positions itself well forward to see the battlefield.

Search and Attack Operations

The search and attack operation is a likely mission for any infantry division. Although brigades and battalions conduct it as a decentralized mission, it requires division support to allocate resources; move troops, supplies, and material; and assimilate and distribute intelligence. The division commander and staff must understand that

search and attack operations are time-consuming. They must allow subordinate commanders enough time to develop intelligence for their AOs before expecting results.

The infantry division conducts search and attack operations against enemy forces with the primary objectives of finding, fixing, and destroying the enemy; destroying or seizing his equipment, food, and safe-base areas; and, whenever possible, destroying his political and military infrastructure. A secondary objective is to keep the enemy on the move and dispersed, to prevent him from planning, assembling, and executing operations on his own initiative. Most search and attack operations are conducted without detailed prior information about the enemy. The commander must produce much of his own intelligence as the operation unfolds. Historically, search and attack operations have been conducted—

Ž In an environment of friendly air and fire superiority.

- Against squad- to company-sized forces equipped with small arms and mortars, but normally without artillery support.

- Against both regular and guerrilla forces whose locations are unknown.
- In an environment where the enemy has the advantage of knowing both the terrain and the local populace.

Ž At company, battalion, and brigade levels with divisional support.

Corps or a JTF may direct a division to conduct combat operations to “clear the enemy in zone.” It maybe to eliminate an enemy’s ability to interfere with current or future combat operation or with a host nation government’s ability to protect its population. Search and attack operations orient on the enemy and not on taking or holding terrain.

A division order directing the conduct of search and attack operations assigns brigade AOs (Figure 3-20 and Figure 3-21, page 3-24) and task organizes them as self-contained forces with combat and CS forces. Brigades normally establish fire support bases for DS artillery and organic mortars. Brigades assign battalions AOs and battalions further subdivide these areas into company zones of action. The tactics and techniques for brigade search and attack operations are covered in FM 7-30.

Maneuver

The success of search and attack operations depends on carefully searching for the enemy and, on finding him, massing superior forces to destroy him. On finding an enemy force, friendly units take one of several actions. If the searching force is able to mass sufficient combat power to overwhelm the enemy, it may conduct a hasty or deliberate attack to destroy the enemy force. If it is not able to mass sufficient combat power, it may keep the enemy force under surveillance until reinforcements and blocking forces arrive. If the search and attack force is discovered by a larger enemy force, it may be forced to withdraw or assume a hasty defense pending reinforcement.

Whenever a contact is made, or intelligence indicates the presence of an enemy force, actions should be taken to entrap or encircle the enemy force. It is not sufficient, in most cases, to use only an attacking and a blocking force. Ground combat units should cover the most likely routes of withdrawal, and light reconnaissance elements, the

less likely routes. They may be placed and extracted by air, or other mobile means, to exploit time and space advantages.

Commanders must be prepared to rapidly adjust plans to enemy movements and alter schemes of maneuver to fix and destroy the enemy. Speed and deception characterize tactical maneuver. While speed is essential, commanders must pay meticulous attention to continuous provision of air, artillery, and, if available, naval gunfire support. The division task organization for a search and attack mission may be as shown in Figure 3-22, page 3-25.

Intelligence

Reconnaissance. Aggressive, continuous reconnaissance is essential in all search and attack operations. Saturation patrolling by platoon- or squad-sized units, either on foot or delivered by helicopter, is a prime source of information. Intelligence acquired through these contacts should be exploited immediately. Commanders must understand and accept that searching is time-consuming and can only be effective if done methodically.

The division long-range surveillance unit (LRSU) observes likely enemy avenues of approach. It also observes and reports on areas the G2 has identified as potential enemy base camps or cache sites. Since some of these operations may occur within brigade areas of responsibility (AORs), the G2 must closely coordinate the collection plan with brigades and exchange information to prevent fratricide or duplication of effort. Use of the LRSU is in addition to the acquisition efforts of brigades and battalions.

The division cavalry squadron is also an integral part of intelligence acquisition. The squadron is in GS to the division. The G2 tasks both air and ground elements with intelligence collection tasks. Like the LRSU, the squadron operates within brigade AORs and must be part of the overall acquisition plan. The division does not give these assets to brigades for their use.

Special operations forces (SOF) within the division AOR are another important intelligence acquisition source. The division can request special reconnaissance missions through the corps

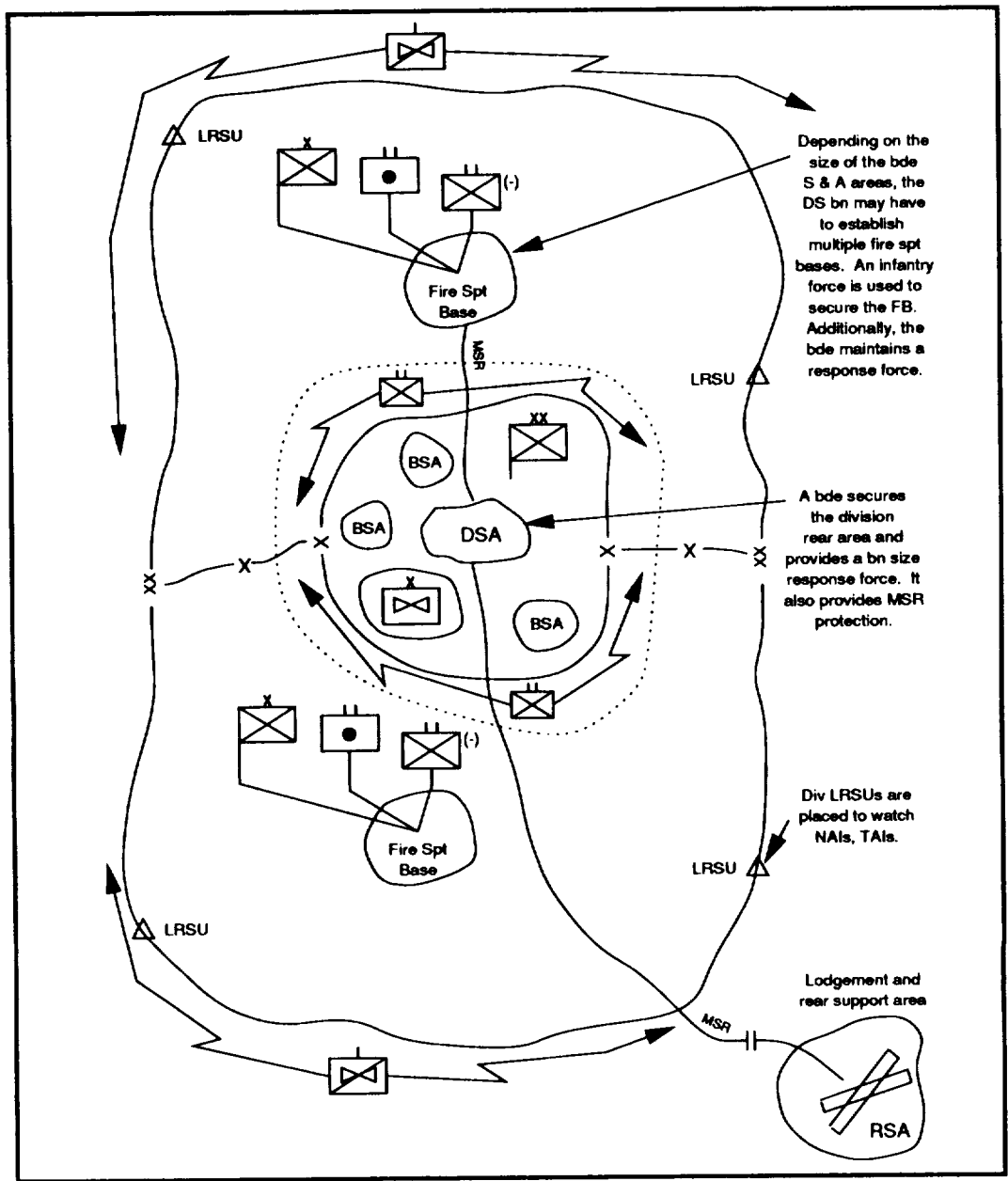

Figure 3-21. Search and attack (continued)

and joint special operations task force headquarters. Division forces must know the locations and missions of these forces to prevent fratricide and duplication of effort.

HUMINT. Information on enemy forces can often be obtained by establishing close liaison with province, district, and village leaders. Frequent visits to local villages by searching forces

can often yield accurate and timely information on local enemy forces. This technique may be especially effective if enemy forces have been oppressive to the local population.

Aerial Surveillance and Acquisition. Aerial platforms can yield valuable information on enemy forces. The division should maximize infrared detection, visual observation, and communications intercept.

<i>1st Bde</i>	<i>2d Bde</i>	<i>3d Bde</i>	
Inf Bn	Inf Bn	Inf Bn	
Inf Bn	Inf Bn	Inf Bn	
Inf Bn	Inf Bn	Inf Bn	
FA Bn (105T) (DS)	FA Bn (105T) (DS)	FA Bn (105T) (DS)	
Engr Co (Lt)	Engr Co (Lt)	Engr Co (Lt)	
ADA Btry (-) (DS)	ADA Btry (-) (DS)	ADA Btry (-) (DS)	
<i>DIVARTY</i>	<i>Avn Bde</i>	<i>DISCOM</i>	<i>Division Troops</i>
FA Btry (155T)	Atk Bn	MSB	Recon Squadron
FA Bde (-) (R)	Aslt Co	FSB	Engr Bn (-)
FA Bde (155SP)	Aslt Co	FSB	ADA Bn (-)
FA Bde (155SP)	Aslt Co:xxx (OPCON)	FSB	MI Bn
		Trk Co:xxx	MP Co
			MP Co:xxx (OPCON)
			CA Co (-) xxx
			PSYOPS Co (-) xxx

Figure 3.22. Typical division task organization: search and attack

Fire Support

Fire support during search and attack operations is provided by artillery, mortars, attack helicopters, CAS aircraft, and, when available, naval gunfire. Brigades establish fire support bases for supporting artillery and organic mortars within brigade AOs. Bases should provide complete coverage of the AO and be mutually supporting. Establishment of these bases will often require insertion and resupply by helicopters. When fire support bases are established, sufficient security forces must be on hand to protect these assets.

Fire support bases should be fully fortified defensive positions that provide all-around security. This includes countermobility obstacles and survivability positions.

Attack helicopters normally operate from the division rear area and are not located within the search AO. They must be positioned, however, to provide rapid and responsive fire support when enemy units are located.

Air Defense

Normally, enemy forces will not have air assets in this environment. In most cases, the division will only require ADA if it conducts operations in proximity to a hostile nation which possesses an offensive air capability. The division G3 normally positions AD assets in the division rear area (DRA).

Mobility and Survivability

The division engineer must understand the search and attack technique being employed by the maneuver brigades and battalions to effectively integrate engineer support. The division engineer allocates engineers to the brigades primarily to support M/S requirements in the brigade close fight and rear area operations. The division engineer will normally task organize engineers in a command relationship based on the nature of decentralized, small-scale search and attack techniques. Typical missions requiring engineer effort include—

- Engineer reconnaissance.
- Breach operations.
- Ammunition cache destruction.
- Protective obstacle support.

Combat Service Support

Combat service support for units conducting search and attack operations normally is provided on an area support basis. Resupply is normally by both ground and air, depending on terrain. Medical evacuation normally is by aerial evacuation to brigade rear support areas. Increases in class V small arms, hand grenades, claymores, and mortar and artillery ammunition can be expected. Forward-deployed units are almost always resupplied with small arms by air. Convoy escorts in

the search and attack environment are critical to protect resupply efforts.

Command and Control

During search and attack operations, the division TAC CP is normally forward deployed in the AO, generally in the vicinity of a major reserve force. The TAC CP's primary mission is to provide division-level intelligence and attack assets to maneuver brigades. The TAC CP commands and controls all divisional assets in support of search and attack operations. This includes the division cavalry squadron and attack helicopters.

Although C² of search operations in the search and attack is usually decentralized, C² of the attack portion must be centralized to be effective. Once an enemy force is discovered, the division or brigade must immediately mass combat power to prevent the enemy's escape. The division controls the helicopter assets needed by brigades and battalions to mass combat power and prevent the enemy's escape. The main CP must make these assets available as quickly as possible.

Rear Operations

The division normally maintains a rear area with division support elements and the aviation brigade. Depending on the tactical situation, at least one brigade probably secures this area, which may be adjacent to the search and attack AOs or some distance away. Both the division main and rear CPs are located in this secured area. The rear CP is responsible for conduct of rear operations.

Reconnaissance in Force

The reconnaissance in force is used when enemy disposition is unknown and the information provided from reconnaissance will outweigh the risk of obtaining it. The infantry division can move forward to do limited reconnaissance in force in rugged or compartmentalized terrain. It can find enemy strong points and weaknesses in the enemy's main defensive positions and create gaps in it. Keys to the success of this mission are coordination and speed. An infantry unit cannot sustain itself over prolonged periods. Thus, the reconnaissance is limited in nature and depends on

corps to take advantage of the information it obtains. The reconnaissance in force finds the enemy and sets the stage for his defeat.

The reconnaissance in force may develop a situation more rapidly than other movement to contact methods. When deciding to conduct a reconnaissance in force mission, the commander considers—

- His knowledge of the enemy situation.
- The efficiency and speed of other intelligence collection assets.
- The extent to which the reconnaissance in force may divulge his plan of action.
- The possibility the reconnaissance in force may lead to a general engagement.

The division has sufficient firepower to cause the enemy to react to probes and limited objective attacks. This discloses his locations, dispositions, strengths, planned fires, and use of reserves. The corps commander must anticipate the enemy reaction to a reconnaissance in force operation and plan either to exploit weaknesses, or withdraw the division pending the assembly of sufficient combat power to destroy or defeat the enemy force.

In this situation (Figure 3-23), the enemy has attacked the corps and committed its second echelon. After several days, the attack has reached its culminating point. The enemy withdraws and initiates a defense out of contact on favorable terrain. The corps commander decides to take advantage of the situation. Due to limited current information on new enemy dispositions and strengths, the commander decides to use an infantry division for a reconnaissance in force mission in preparation for a corps attack. The terrain immediately to the front of the corps is rugged and suited for infantry operations.

The corps commander's concept requires the division to move through the enemy security zone, identify the main defensive positions, find weak areas or gaps, and attack to create or widen gaps for the corps to exploit.

Maneuver

The infantry division commander analyzes the mission. He knows this enemy has a security

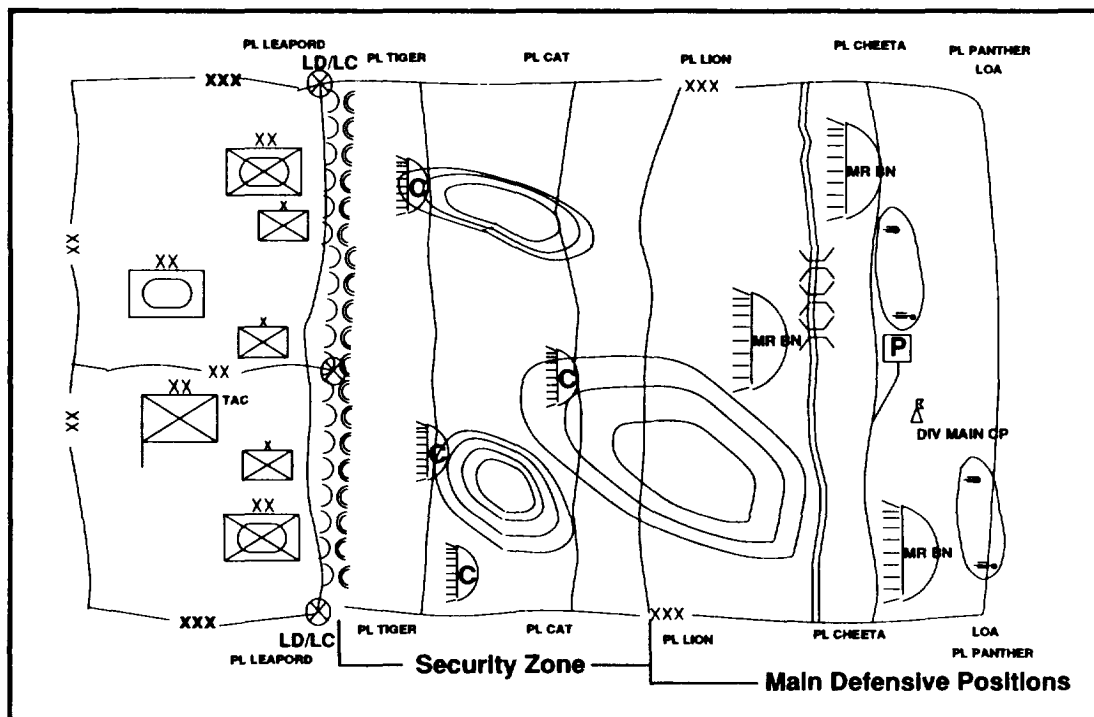

Figure 3-23. Corps situation: reconnaissance in force

zone in front of a main defensive position. The security zone is normally 15 to 20 kilometers in depth and fortified by strong points with overlapping and interlocking indirect and direct fire systems.

The enemy main defensive position is constructed with mutually supporting positions and supported by his regimental and division artillery. Since the enemy has had limited time to dig in, it is important to get through the enemy's security zone as soon as possible.

The division will conduct a reconnaissance in force using probes and limited objective attacks to discover enemy strengths and weaknesses. It should then be able to pick locations to conduct deliberate attacks to create a gap or gaps to support the corps attack and penetration.

To accomplish his mission, the division commander task organizes the division as shown in Figure 3-24, page 3-28. Corps provides additional artillery and aviation assets to aid the mission; these assets are OPCON to the division.

Deep Operations. The infantry division has no deep operation during a reconnaissance in

force mission. Corps provides intelligence and conducts operations beyond the division AO. The corps looks deep to provide early warning and interdict enemy movement of additional units into the sector.

Close Operations. The corps establishes a clearly defined reconnaissance AO to the front of the corps area of operations supporting the upcoming corps attack. The division then establishes brigade reconnaissance zones within its AOs (see Figure 3-25, page 3-28). The factors of METT-T determine brigade zones, widths, and depths.

The division mission is planned as a three-phased operation. In phase one, the division moves quickly through the security zone. The defending division supports the passage of brigades through its lines. Brigades seek to avoid contact with the enemy in the enemy security zone but report enemy dispositions and weapons systems. If contact is made, units attempt to break contact and continue movement toward the enemy's main defensive position. If units become decisively engaged in the security zone, defending divisions provide fire support and other

1st Bde	2d Bde	3d Bde	
Inf Bn	Inf Bn	Inf Bn	
Inf Bn	Inf Bn	Inf Bn	
Inf Bn	Inf Bn	Inf Bn	
FA Bn (105T) (DS)	FA Bn (105T) (DS)	FA Bn (105T) (DS)	
Engr Co (Lt) (DS)	Engr Co (Lt) (DS)	Engr Co (Lt) (DS)	
ADA Btry (-) (DS)	ADA Btry (-) (DS)	ADA Btry (-) (DS)	
DIVARTY	Avn Bde	DISCOM	Division Troops
FA Btry (155T)	Atk Bn	MSB	Recon Sqdn
FA Bde (R)	Aslt Co	FSB	Engr Bn (-)
FA Bn (155SP)	Aslt Co	FSB	ADA Bn (-)
A Bn (155SP)	Aslt Co/xxx (OPCON)	FSB	MI Bn
FA Bn (MLRS)		Trk Plt/xxx	MP Co

Figure 3.24. Division task organization: reconnaissance in force

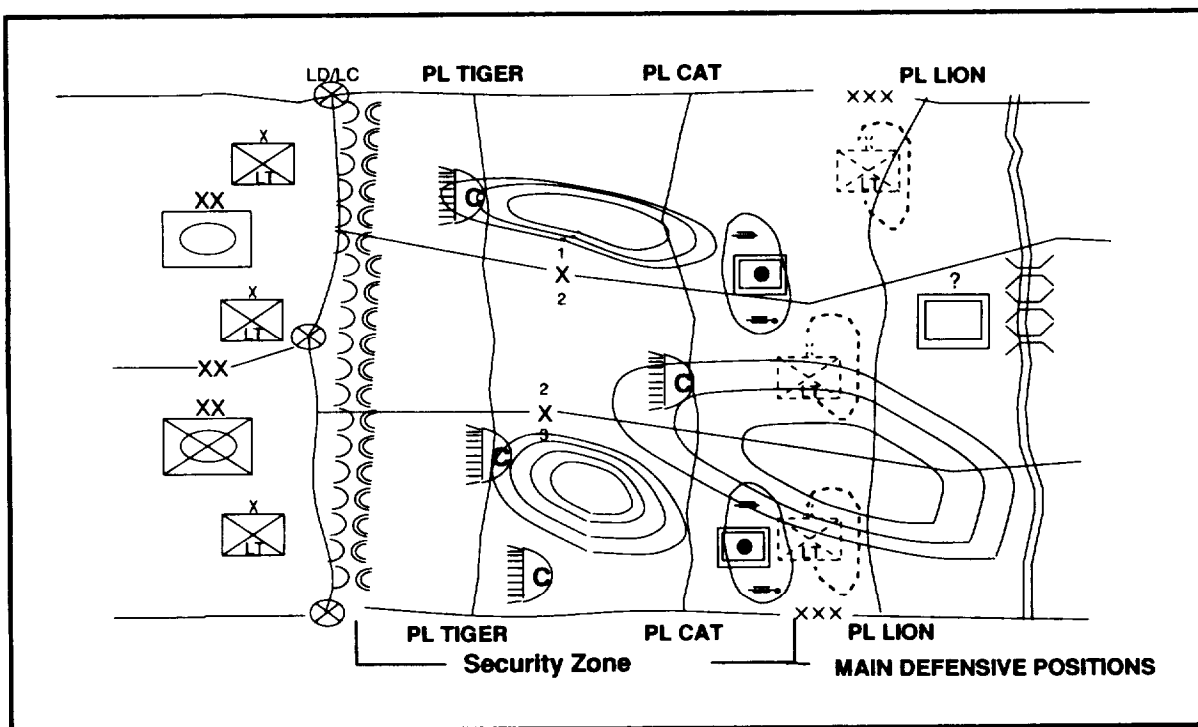

Figure 3.25. Division concept of operations: brigade zones

assistance to help defeat the enemy force or expedite disengagement.

In phase two, the purpose of the operation is to locate the enemy's main defensive position and to conduct aggressive patrolling operations to find weak areas or gaps in the enemy defense.

In phase three, the focus is on the attack of weak areas to create a gap for passage of the lead

division of the corp attack. The infantry division may place its reconnaissance squadron OPCON to the lead division to facilitate linkup and passage of the corps' main attacking force.

Rear Operations. The rear CP controls the division's rear area. Since the division will be in the defending division's forward areas, the corps has designated assembly areas controlled by the

infantry division. The rear CP coordinates movement control and terrain management for these areas and routes to release points with the in-place division. The infantry division rear CP coordinates rear area security with the defending divisions. There is no TCF.

Reserve Operations. The division reserve, the aviation brigade, is located in the division rear area. It can also conduct on-order attack helicopter operations to support both the reconnaissance in force and the attack to create a gap. It can rapidly focus firepower, providing the commander the ability to take advantage of unexpected opportunities or to assist in disengagement operations.

Intelligence

The infantry division's G2 conducts the IPB of the area where the reconnaissance in force is to be conducted. Using doctrinal templates, the G2 approximates enemy locations and possible gaps in the security zone and main defensive positions. The commander's PIR for the reconnaissance in force are to locate enemy strong points in the security zone, find the main defensive positions, and locate weak points or gaps in the main defensive positions.

The G2 develops a collection plan to provide PIR for the commander. Brigades execute the collection plan. As information flows back to the G2 from the brigades, the G2 adjusts the IPB to confirm actual enemy locations on the situational template.

The MI battalion keeps the majority of the division intelligence assets in the division rear area near the LD. These are used as corps assets to collect information and jam enemy C2 nodes as they are located. The corps uses the infantry division's intelligence assets to support its attack until linkup.

Fire Support

Fire support for the reconnaissance in force consists of the organic artillery of the division, a FA brigade (OPCON), and the defending division's artillery. The DIVARTY positions GS and GSR artillery after clearing positions through the division FSE. Corps priority of fires is to the

infantry division until the corps attack begins. Artillery is positioned on the friendly side of the forward line of own troops (FLOT) and does not initially move with the infantry division. At no time is the reconnaissance in force out of the range of FA coverage. All available artillery is positioned to provide fires in depth for the reconnaissance in force elements (Figure 3-26, page 3-30).

Brigades in DS to artillery battalions are prepared to conduct air assault operations to provide deep fires, if required, to support brigade probes. They can also support limited-objective attacks or, in the deliberate attack, create gaps in the enemy's main defensive positions. Corps provides long-range artillery support to the division by assigning a FA brigade and giving the GSR mission to the defending division artilleries.

The DIVARTY positions firefinder radars after clearing positions through the division FSE. Their primary mission is counterfire. Destruction of the enemy's artillery are critical to the success during all phases of the operation.

Close air support is coordinated for the attack on HPTs. The priority during all phases of the attack will be the destruction of enemy artillery.

The FSE recommends positioning EW assets to support attacks on enemy C² nodes. This disrupts communications between the security zone and main defensive positions.

Target information collected by the reconnaissance is passed to the infantry division where it is processed for developing integrated, coordinated, and synchronized corps and division fire support plans. The corps and divisions use these plans in executing the corps attack. Target planning is continuous and constantly updated to support all phases of the division mission. The use of global positioning systems (GPS) by infantry reconnaissance forces allows for pinpointing detected enemy in both the security zone and main defensive positions. This allows for their suppression or destruction by artillery and CAS.

Mobility and Survivability

During the reconnaissance in force, priority of engineer work is mobility reconnaissance. Engineers with brigades report locations of

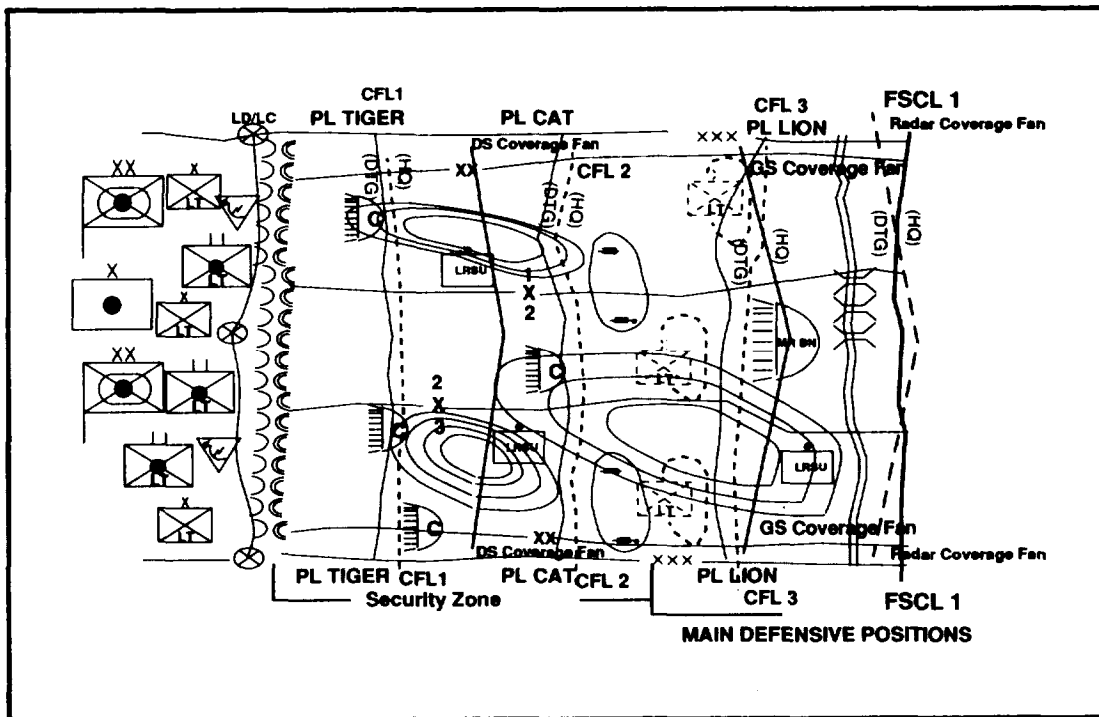

Figure 3.26. Division concept of operation: fire support

enemy obstacles to facilitate future operations. Marking of bypasses, preparation of breach lanes, and limited route clearance operations are executed given time and resources. Remaining divisional engineer assets stay in the engineer battalion near the LD. Once the division attacks and penetrates an enemy weak point, the engineer priority shifts to countermobility and survivability. In this phase engineers seal the battlefield by planning FASCAM in and around the gap created.

Air Defense Artillery

Protection of the force is vital during the reconnaissance. The ADA battalion provides assets to each brigade to aid the operation. ADA teams accompany brigades in their reconnaissance with MANPAD systems. The ADA battalion retains and deploys other systems in the rear. Corps provides high to medium altitude air defense (HIMAD) coverage to the division.

The primary means of AD for the reconnaissance in force are passive camouflage techniques and MANPAD systems.

Combat Service Support

Brigades initially carry enough supplies forward for 48 to 72 hours of operations. The MSB and FSBs are located well forward close to the FEBA, keeping a minimum distance from the maneuver brigades. Once MSR is secured, convoys push supplies forward (Figure 3-27). The rear CP coordinates with the attacking division and corps for MSR to resupply the forward infantry positions by ground vehicles. Resupply convoys initially carry only those items necessary to maintain the division's attack. As the corps attack proceeds, additional routes and convoys continually resupply the infantry division.

Command and Control

The division establishes control measures within brigade sectors to coordinate actions.

The TAC CP is well forward and collocated with the corps lead division's TAC CP to coordinate the operation. Brigades report their own and enemy locations to the infantry division TAC CP. This information is passed to the main CP and to corps to facilitate planning for the attack. The

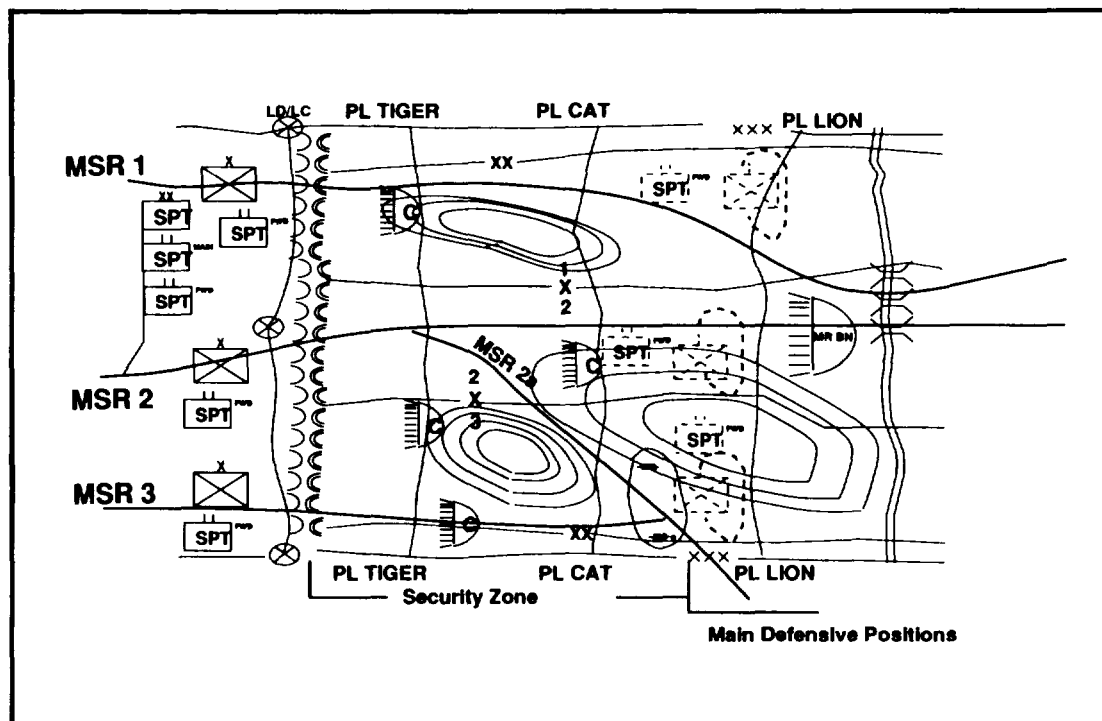

Figure 3-27. Division concept of operations: combat service support

TAC CP moves with the attacking lead division, while the main CP stays in position to facilitate future operations. The rear CP remains in place but moves forward on order from the main CP.

EXPLOITATION AND PURSUIT

The infantry division conducts exploitation and pursuit operations to take advantage of a weakened or collapsed enemy defense. The exploitation's purpose is to prevent the enemy from reconstituting a defense and withdrawing to other defensible terrain, and to destroy his command and control. The exploitation may follow a deliberate or hasty attack when—

- The enemy is unable to maintain or establish a defense.
- The enemy's artillery and C² positions are overrun.
- There is an increase in captured enemy equipment and prisoners.
- Enemy supply dumps are captured.

The pursuit normally follows a successful exploitation. Its intent is to completely destroy

the enemy force. The transition from exploitation to pursuit begins when—

- The division advances without a strong enemy reaction.
- There is an increased number of captured prisoners, abandoned weapons, and unburied enemy dead.
- There is a lessening of enemy artillery fire.
- There is a lack of enemy obstacles.

The division executes the pursuit when the enemy tries to escape. The commander normally uses a direct pressure force, usually the lead force from the exploitation, and an enveloping force to block the enemy's escape. The intent is to catch the enemy between these two forces and destroy him.

Decentralized execution characterizes exploitation and pursuit operations. However, the corps commander and his staff continuously monitor exploitation and pursuit operations to prevent the division from overextending the corps and to prevent it from being put at risk by an enemy counterattack.

Although transitioning from the attack to the exploitation and pursuit may present a major opportunity to destroy enemy forces, extreme care must be exercised. Too rapid an advance risks overextending lines of supply and communications. This may give the enemy an opportunity to isolate the pursuing force, or to counterattack into an exposed flank.

The transition from deliberate attack to exploitation and pursuit may be abrupt or so gradual it is hardly distinguishable from current operations. Once the transition is conducted, every effort is made to maintain pressure on the enemy. Small enemy units are bypassed by the direct pressure force unless they are a threat to the division or cannot be bypassed. These bypassed forces are destroyed by maneuver elements of the division main body or by follow and support operations of other units. The exploiting force directs follow and support units to enemy positions.

Maneuver

In this example (Figure 3-28), the infantry division has conducted a deliberate attack as part of

an overall corps attack. The division took its initial objectives with little or no organized resistance. The commander reported the situation and has been directed to continue the attack. Intelligence confirms enemy strength is lower than originally thought and the enemy is trying to assume hasty defensive positions. The enemy is establishing a defense out of contact near objective EAGLE. The division exploitation operations objectives are to seize objectives EAGLE and HAWK.

Contingency plans for exploitation and pursuit operations are sequels in planning for the deliberate attack. There is no change in task organization for the exploitation from the deliberate attack (see Figure 3-29).

Deep Operations

The division has no deep operations. As the lead element in the corps deliberate attack, the division depends on corps and higher headquarters to look deep. Corps provides intelligence and early warning of changes to enemy forces in the division area of interest.

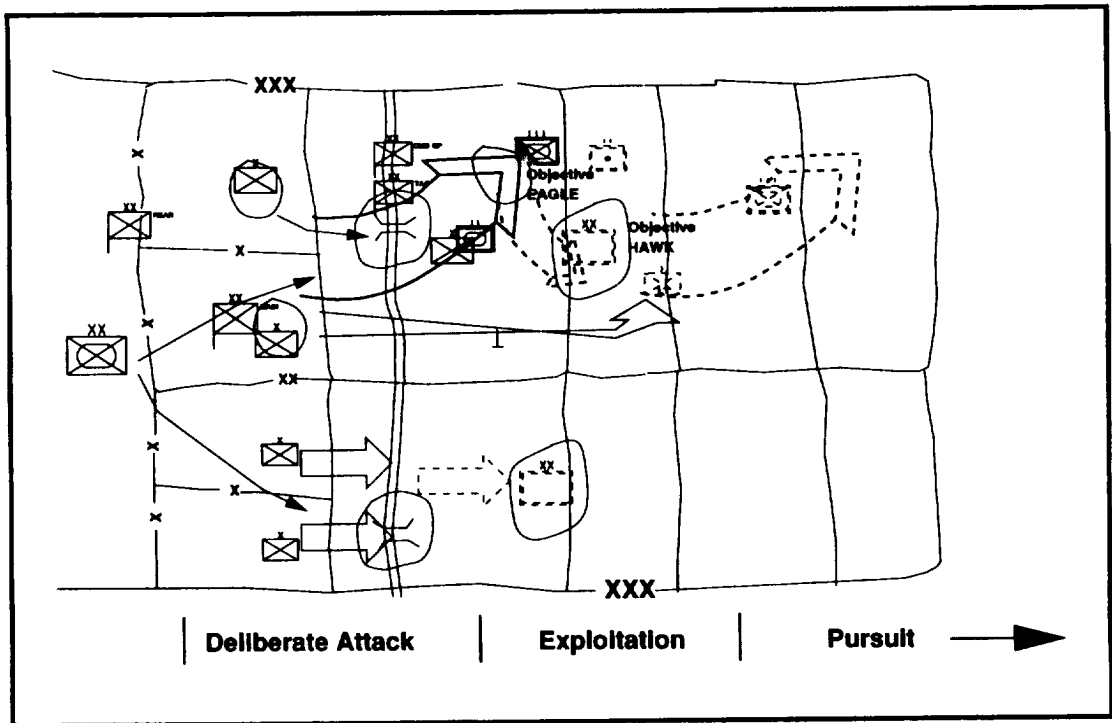

Figure 3.28. Exploitation and pursuit: corps situation

<i>1st Bde</i>	<i>2d Bde</i>	<i>3d Bde</i>	
Inf Bn	Inf Bn	Inf Bn	
Inf Bn	Inf Bn	Inf Bn	
Inf Bn	Inf Bn	Inf Bn	
FA Bn (105T) (DS)	FA Bn (105T) (DS)	FA Bn (105T) (DS)	
MI Plt	MI Plt	MI Plt	
Engr Co (-) (Lt)	Engr Co (-) (Lt)	Engr Co (-) (Lt)	
ADA Btry (-)	ADA Btry (-)	ADA Btry (-)	
FSB Team	FSB Team	FSB Team	
<i>DIVARTY</i>	<i>Avn Bde</i>	<i>DISCOM</i>	<i>Division Troops</i>
Btry (155T) (GS)	Atk Bn	MSB	Recon Sqdn (-)
FA Bde (R) DIVARTY	Aslt Hel Co (2)	FSB (-)	MI Bn (-)
FA Bn (155SP) (R)	Aslt Hel Co	FSB (-)	ADA Bn (-)
FA Bn (155SP) (R)	xxx (OPCON)	FSB (-)	Engr Bn (-)
FA Bn (MLRS)			MP Co
			MP Co/xxx (OPCON)

Figure 3-29. Division task organization: the exploitation

Close Operations

The commander's intent is to prevent the enemy from reconstituting his defense and prevent his withdrawal by securing objectives EAGLE and HAWK, then execute pursuit operations if he attempts to retreat. (This is a force-oriented mission.) The commander's concept is to continue the attack, maintaining direct pressure on the enemy, forcing him to fight, and thereby setting the conditions for his envelopment and destruction (Figure 3-30, page 3-34).

The reconnaissance squadron finds the enemy; the advance guard and other lead brigade maneuver units fix the enemy while trailing brigades move to envelop him. If the enemy attempts to withdraw, division aviation assets are directed to conduct air operations to block his withdrawal. If the enemy is able to withdraw and is retreating, the division begins pursuit operations, informs corps of the situation, and maintains pressure on the enemy. Air assault operations are used to block the enemy during the pursuit. The objective is to stop the enemy and either destroy him or force him to surrender.

Rear Operations

The division rear is located where it was when the deliberate attack started, the defending division's brigade areas. The attacking brigades are reinforced prior to the attack to sustain the attack

and support possible exploitation operations. The rear CP plans for exploitation and pursuit operations prior to the deliberate attack. Coordination for transportation, routes, and logistics resupply is accomplished directly with corps once the exploitation starts. Security for the infantry division rear is coordinated with corps as the defending units move forward. The rear CP moves on order.

Security Operations

Direct pressure and speed are critical to security during exploitation and pursuit operations. The corps commander must look deep to ensure enemy reinforcements or counterattack forces do not surprise the exploiting force. The corps commander may stop the operations when the exploiting or pursuing force has overextended the corps' capability to synchronize and integrate operations or when there is a risk to the force which the corps cannot counter.

Close-in division security is a brigade responsibility. Brigades extend security to the flanks and maintain contact forward and to the rear during the exploitation and pursuit. Aviation assets are used to envelop the enemy. Security for air assaults are coordinated between affected units by the TAC CP. Integration of CAS and indirect fires seals LZs off from the enemy and prevents him from moving.

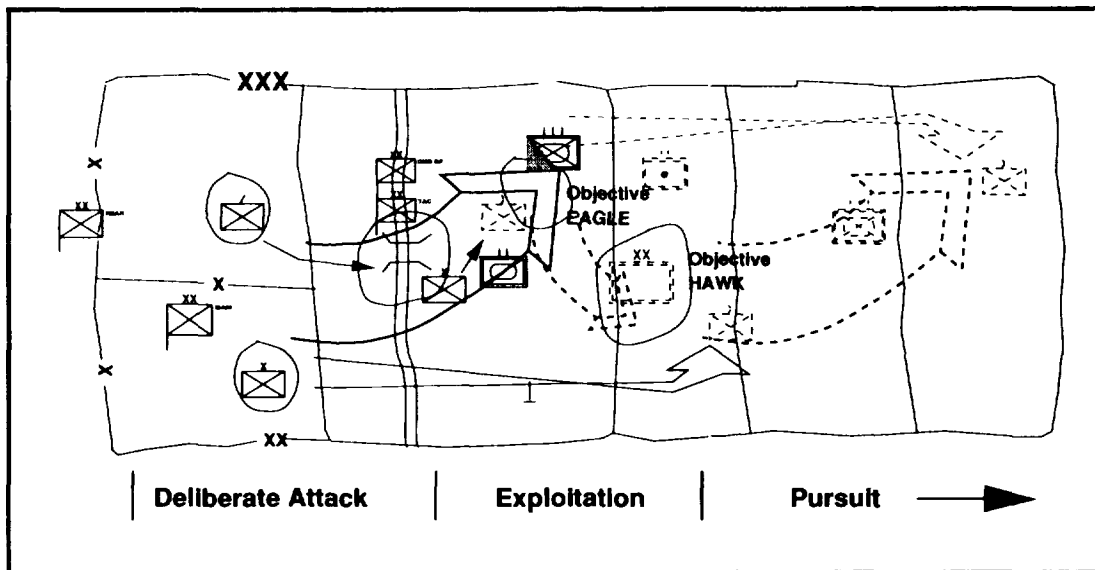

Figure 3-30. Exploitation and pursuit: maneuver

Reserve Operations

The division has no reserve. The corps has assigned a follow and support force to assist the division.

Intelligence

Based on the commander's guidance, the division plans to conduct exploitation and pursuit operations, if appropriate, after the attack. The commander's PIR are the locations and sizes of enemy units. The G2 bases his collection plan on the commander's PIR. The plan depends on intelligence from advancing divisional forces and the deep-look capability of division and higher headquarters MI assets. Battlefield damage assessment is incorporated into the collection plan to support the commander's PIR.

The G2 plans the insertion of division LRSD teams to observe activity in and around objectives and to look deep. Electronic collection systems are emplaced on the friendly side of the LD and are moved to forward positions on order as the situation permits. Air platforms fly patterns progressively deeper as enemy territory comes under friendly control. Enemy prisoner of war integration teams are assigned to forward maneuver units. They must quickly gather information as prisoners are captured.

Electronic warfare jamming systems support the attack. They are positioned to degrade enemy C² during the initial attack and the exploitation and pursuit.

Fire Support

The division FSE develops fire support task organization and coordination measures for deliberate attack and exploitation and pursuit contingency plans (see Figure 3-31). The FA organization for combat provides a fire support and radar umbrella to protect advancing forces during the attack, exploitation, and pursuit. Fire support control measures provide for rapid coordination of fire support to maneuver forces (see Figure 3-31). Direct support artillery, organic to the division, moves with maneuver brigades and provides artillery fire support. Artillery may be air-assaulted to provide increased firepower to assist in the envelopment of enemy maneuver forces. Corps artillery assets move behind the lead maneuver brigade. Close air support and attack helicopters destroy enemy artillery out of range of friendly artillery.

Counterbattery and countermortar radars are positioned to maintain radar coverage over forward maneuvering forces (the reconnaissance squadron and advance guard). The DIVARTY

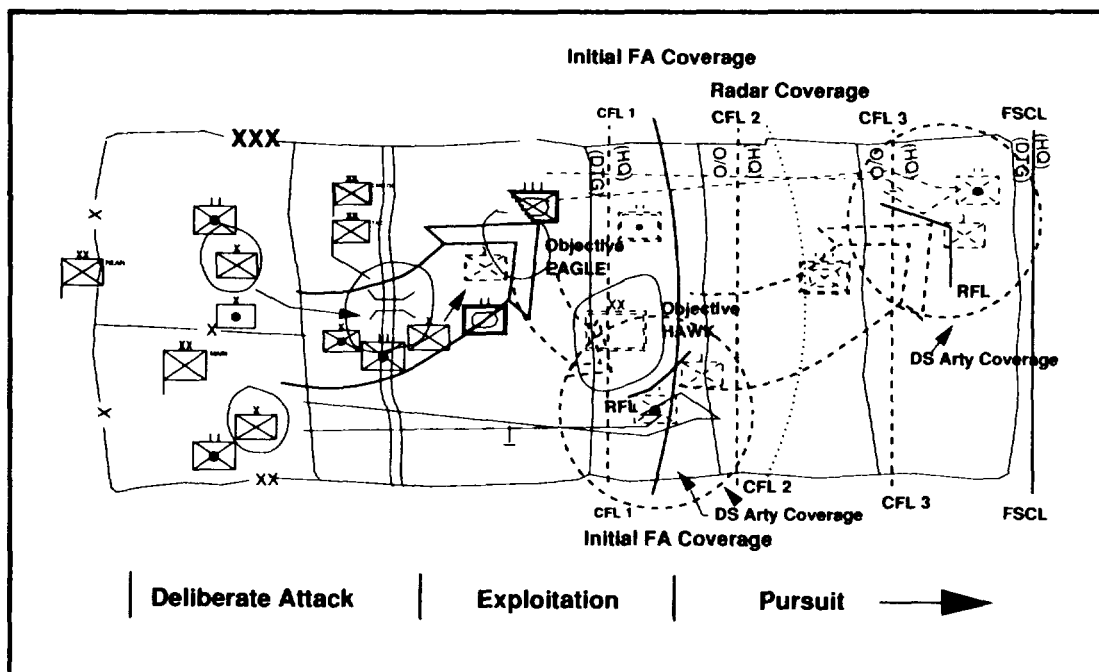

Figure 3.31. Exploitation and pursuit: fire support

manages radar coverage to ensure continuous coverage during the rapid movement forward.

Combat operation laser teams (COLTs) are task-organized to weight fire support to the lead elements.

Mobility and Survivability

Engineers are task-organized to support the exploitation and pursuit. Their priority is to enhance mobility, Light engineer companies move with each brigade and a team is in DS to the reconnaissance squadron. Engineers report and remove obstacles as they are found. Each trailing light engineer company enlarges the maneuver area.

The division engineer works with the G2, G3, and FSE to plan FASCAM minefield to block the enemy's withdrawal. The corps engineer work line moves forward with the follow and support division.

Air Defense Artillery

Air defense artillery focuses on likely enemy air avenues of approach which might interfere with the attack, exploitation, or pursuit. The

corps commander weighs the enemy's ability to obtain local air superiority when a division executes exploitation or pursuit operations. Corps and division ADA assets move forward rapidly to cover and protect vital points the enemy may try to attack.

Combat Service Support

Staff planners prepare contingency plans when planning the deliberate attack. These plans address the continuation of the attack and its transition into the exploitation and pursuit. Priority of support is to resupply of class I and V and evacuation of wounded. Each unit receives a tailored CSS support package following the attack to support exploitation and pursuit operations. Resupply is pushed to units by both ground and air assets. (See Figure 3-32, page 3-36.)

Command and Control

The division TAC CP exercises C² during the attack and during exploitation and pursuit contingency operations. The corps tactical CP monitors the transition from the attack to exploitation and pursuit operations.

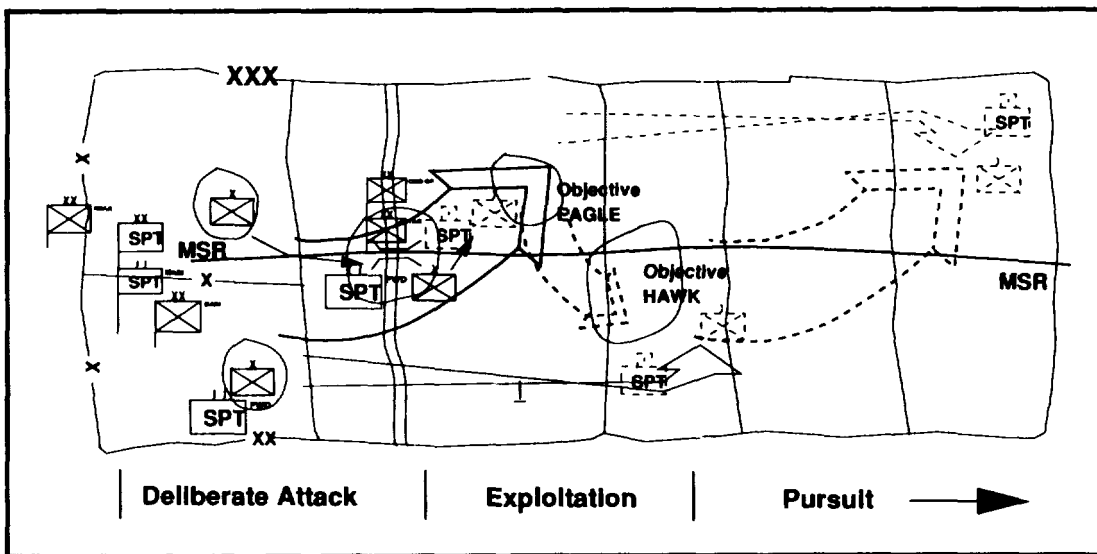

Figure 3-32. Exploitation and pursuit: combat service support

The TAC CP and command group move behind the lead brigade of the division. The TAC CP maintains contact with the reconnaissance squadron and advance guard. As enemy forces are fixed or bypassed, the TAC CP issues appropriate orders. The TAC CP passes locations of bypassed units to the main CP which in turn coordinates the actions of follow and support units.

The rear CP pushes units and supplies forward in coordination with the TAC CP, main CP, and follow and support unit. The rear CP's primary concerns are deconfliction of ground routes and logistics support to forward elements. The rear CP assigns separate MSRs when coordinating with a follow and support unit.

FOLLOW AND SUPPORT

The infantry division may be assigned the mission of follow and support. As a follow and support force, the division is not a reserve. It is a committed force provided with the appropriate amount of combat, CS, and CSS assets to accomplish its mission. As a follow and support force, the division must retain the agility and flexibility to respond rapidly to the needs of the supported force. A successful follow and support force provides the lead division with the ability to regenerate combat power and maintain offensive momentum. The follow and support force can—

- Relieve halted units and contain or destroy enemy forces specified by the supported commander.
- Secure key terrain along routes which support the main effort.
- Widen or secure an area of exploitation.
- Block movement of enemy reinforcements into an area or guard prisoners, key areas, and installations.

The follow and support mission requires centralized planning and decentralized execution. The division can expect to commit elements piecemeal, from company to battalion size, when reacting to bypass situations created by the lead division. Because of transportation mobility differences, the infantry division will probably need augmentation to achieve mobility comparable to that of the division it supports.

In this example, the corps attack has succeeded. Objective SNAKE has been secured with little resistance (Figure 3-33). The corps commander sees an opportunity to execute a pursuit. He directs the infantry division to conduct follow and support missions behind a lead mechanized division to prevent “bleeding off” combat power during the pursuit. The corps commander’s guidance to the mechanized division commander is to bypass (and maintain

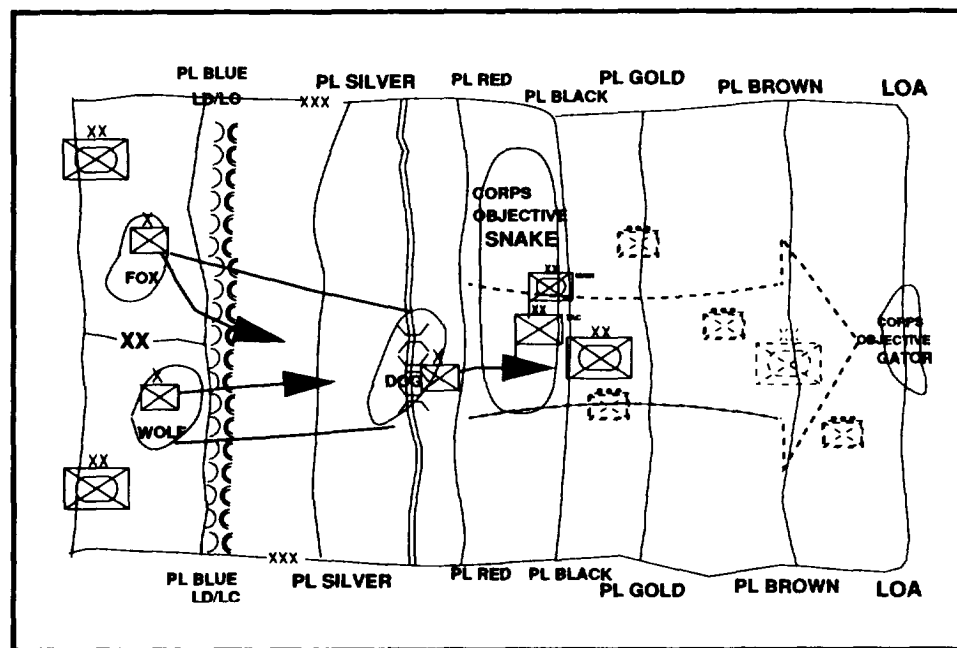

Figure 3-33. Follow and support concept of operations: corps' concept of the operation

observation on) enemy units up to company size. His intent is to maintain the momentum of the pursuit. In this tactical situation—

- The division remains attached to the corps.
- ŽThe division has been resupplied.
- Current strength is 80 percent overall or greater.
- ŽRandom and intermittent fighting is still occurring.
- LOCs from corps to the lead division are secure.
- Terrain is restrictive, but has sufficient avenues of movement to permit heavy forces to conduct the pursuit.
- Stay-behind enemy units are expected to defend throughout the area.

Maneuver

The corps main effort is to pursue enemy forces rapidly with an armored division while the infantry division conducts follow and support operations. The infantry division commander has developed his concept of the operation within the offensive battlefield framework. To accomplish the follow and support mission, the commander

task organizes the division as shown in Figure 3-34, page 3-38.

Deep Operations

The follow and support force has no deep operation. However, the lead division continues to tight both deep and close operations. The division receives intelligence and tasks based on operations conducted by the lead division. The lead division directs the follow and support force to enemy locations.

Close Operations

The follow and support division follows the lead division with brigades in column and the TAC CP and reconnaissance squadron well forward. The TAC CP assigns missions to the lead brigade as the pursuit develops until all forces of the brigade have been committed. Then, the second brigade assumes the lead until all its units are committed. Finally, the last brigade assumes the lead.

The division has additional corps transportation assets to aid mobility. It tailors each mission to use available air and wheeled assets to move to required locations. The division moves on foot only as a last resort. To improve communications and see the battle, the division reconnaissance

<i>1st Bde</i>	<i>2d Bde</i>	<i>3d Bde</i>
Inf Bn	Inf Bn	Inf Bn
Inf Bn	Inf Bn	Inf Bn
Inf Bn	Inf Bn	Inf Bn
FA Bn (105T) (DS)	FA Bn (105T) (DS)	FA Bn (105T) (DS)
Engr Co (Lt) (DS)	Engr Co (Lt) (DS)	Engr Co (Lt) (DS)
ADA Btry (DS)	ADA Btry (DS)	ADA Btry (DS)
IEW Team	IEW Team	IEW Team
FSB	FSB	FSB
<i>DIVARTY</i>	<i>Avn Bde</i>	<i>Division Troops</i>
FA Btry (155T)	Atk Bn	Cav Sqdn
FA Bde (R)	Aslt Hel Co	Engr Bn (-)
FA Bn (155SP)	Aslt Hel Co	ADA Bn (-)
FA Bn (155SP)	Aslt Hel Co:xxx (OPCON)	MI Bn (-)
FA Bn (MLRS)		MP Co
		Trk Co (OPCON)

Figure 3-34. Follow and support concept of operations: division task organization

squadron (ground troop) and division TAC CP move to the rear of the rear brigade of the lead armored division.

Once the lead division locates enemy units and has them under observation, it hands off the enemy units to the follow and support division. This is first received as a task in the follow and support TAC CP. As the lead division moves, the reconnaissance squadron maintains contact with the trailing brigade. The TAC CP directs the reconnaissance squadron to send elements to the lead division unit observing the bypassed enemy.

The reconnaissance elements link up with the unit and relay critical information to the TAC CP. They expedite the follow and support lead brigade unit's assumption of the task. Reconnaissance elements remain on site to guide the lead brigade into position, provide liaison, or establish contact and coordination points. Once the handoff is completed between the follow and support brigade and the observing unit, the reconnaissance squadron moves to a location specified by the squadron CP. When the lead infantry brigade assumes its first mission, the TAC CP establishes brigade boundaries, beginning with the creation of a brigade AO (see Figure 3-35). When all the forces of the lead brigade have been committed, the TAC CP designates the brigade's area of interest and assigns the next brigade to the following mission.

Brigade commanders determine the appropriate force required for each mission. The division provides assets to accomplish follow and support requirements as needed or requested. The TAC CP commits attack helicopter elements and TACAIR as required to support each committed brigade.

Brigades continue to be committed as necessary until the follow and support division is fully committed or receives a change of mission. When all brigades are fully committed and the division can no longer conduct the follow and support mission, corps must then assign the mission to another unit. (See Figure 3-36, and Figures 3-37, and 3-38, page 3-40.) If brigades accomplish assigned missions and are still able to mass sufficient combat power to continue the follow and support mission, the division continues to fight.

Once brigades are fully committed, they respond to C² from the main CP. The lead brigade and reconnaissance squadron continue to work under the C² of the TAC CP. The main CP arranges for fully committed brigades to turn over their AO to other organizations when they secure the areas or have completed their assigned tasks. Brigades are then available to continue the follow and support mission without a loss of offensive momentum. Brigade units provide flank and route security while trailing the lead division.

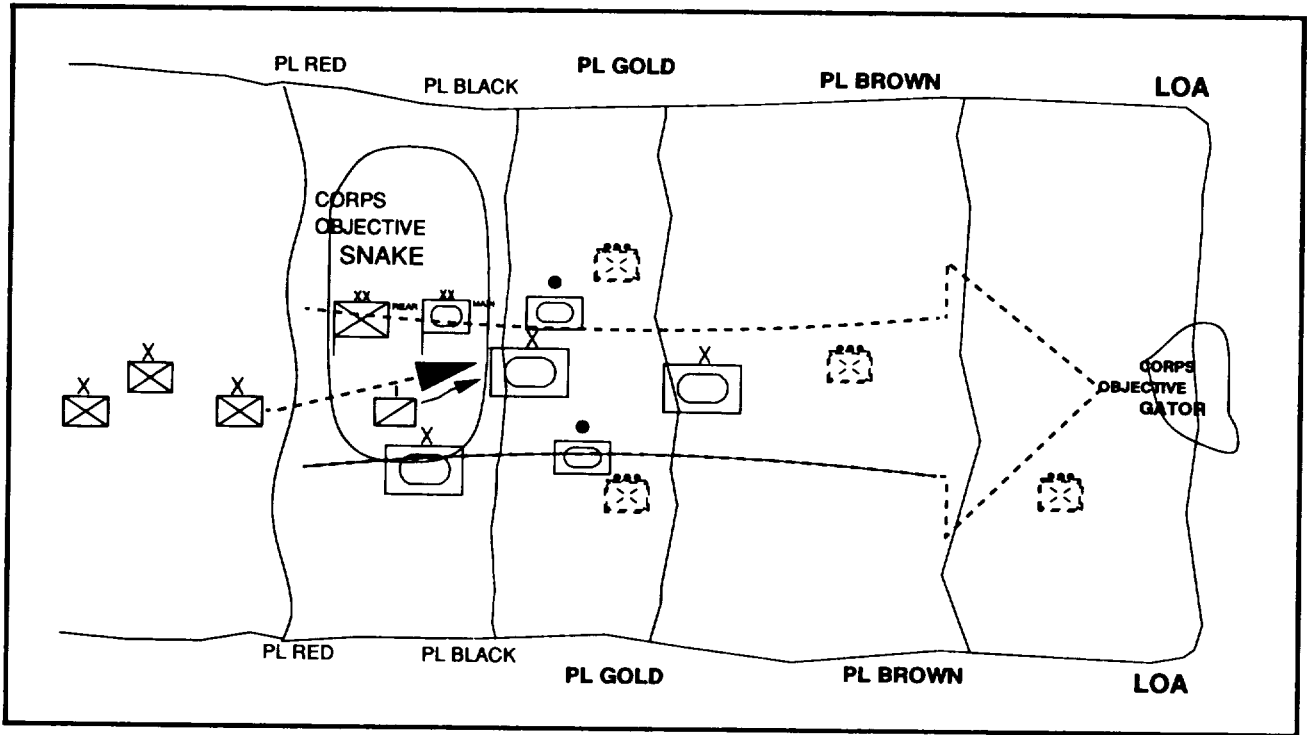

Figure 3-35. Follow and support concept of operations: maneuver

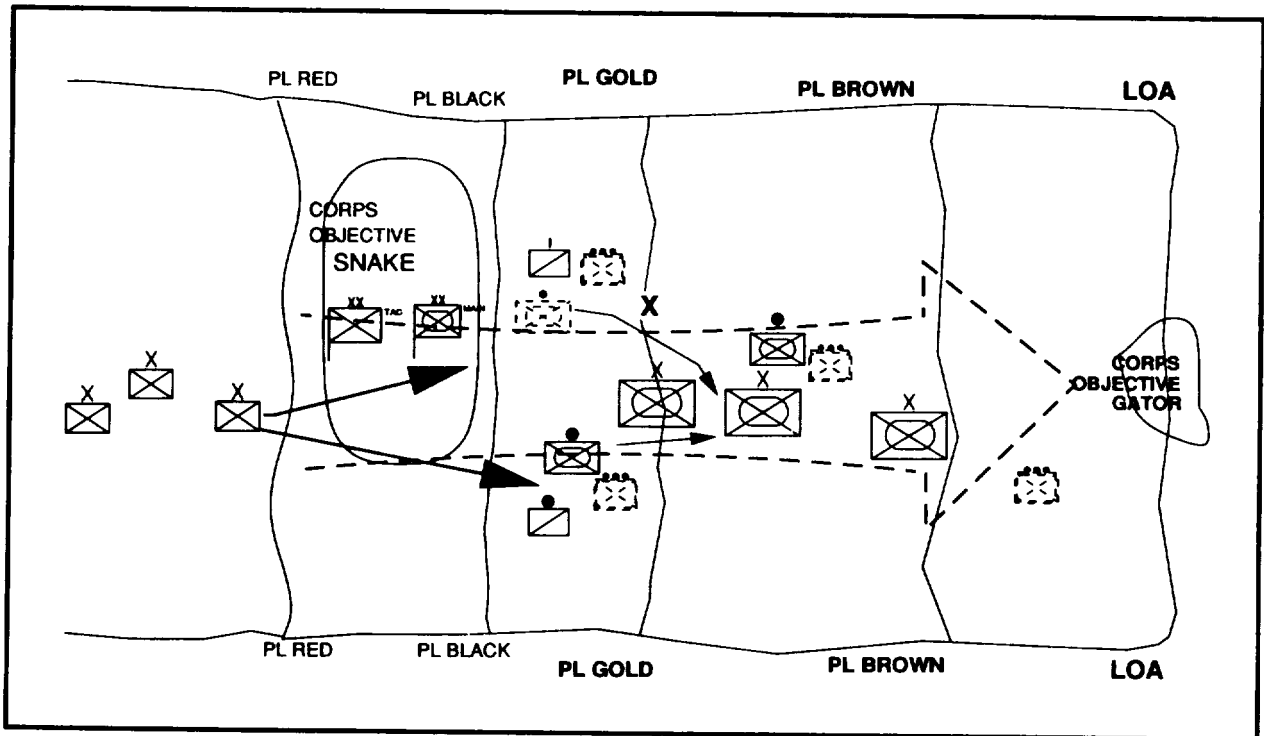

Figure 3-36. Follow and support concept of operations: maneuver

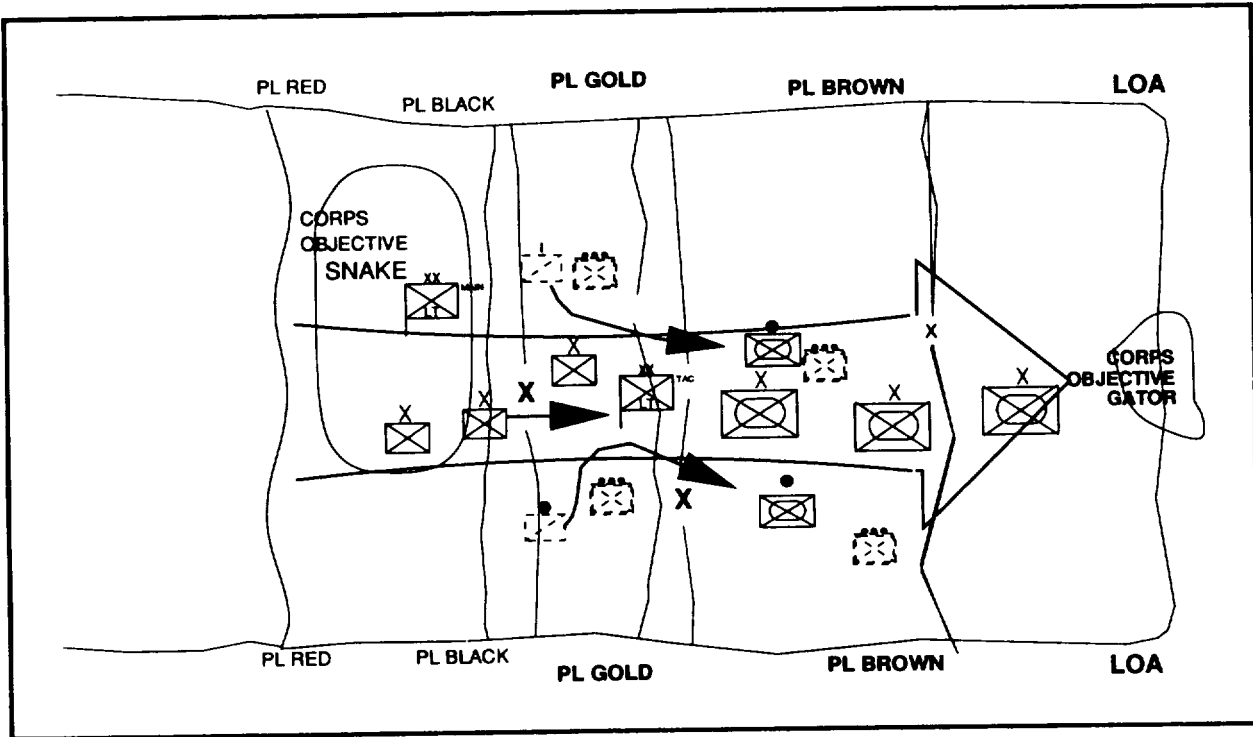

Figure 3-37. Follow and support concept of operations: maneuver (continued)

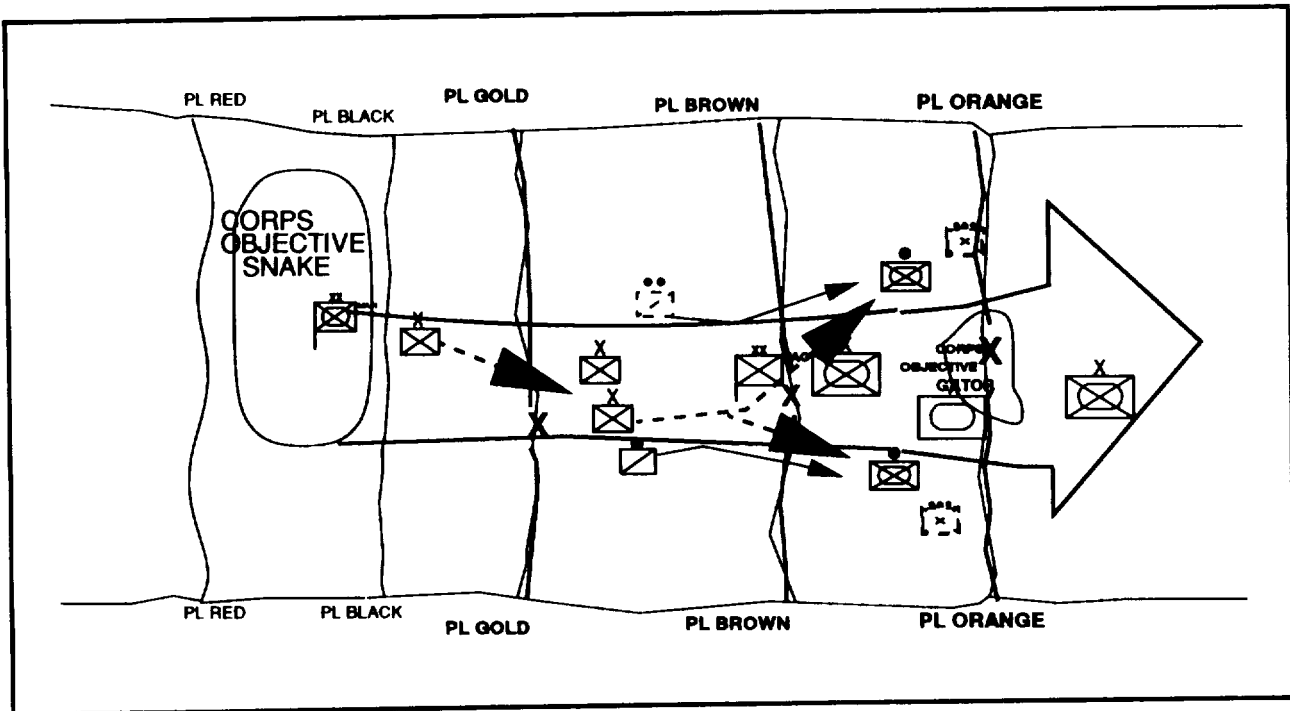

Figure 3-38. Follow and support concept of operations: maneuver (continued)

Rear Operations

The rear CP controls the division's rear area. Its primary concerns are sustainment, terrain management, movement of forces forward, and security of the division rear. Utilizing MP elements, the rear CP establishes movement control and terrain management from the previous division rear area to the trailing infantry's brigade rear boundary. The rear CP, main CP, and corps COSCOM manage logistics forward through the division without interfering with follow and support operations. As brigades move forward the division adjusts its rear area.

Security Operations

Close and continuous coordination between the lead division and the reconnaissance squadron maintains forward security. Brigades secure the division flanks and rear driving movement. The rear CP coordinates rear security with the corps. It immediately responds to a threat with an on-order mission to the division aviation brigade and fire support units.

Reserve Operations

No division reserve is assigned for this mission. Follow and support divisions do not routinely require reserve forces, although brigades should designate reserves to reinforce committed units.

Intelligence

The division G2 maintains continuous and direct contact with corps and lead division intelligence staffs to obtain current information on enemy forces and to anticipate future tactical requirements. Close coordination between division intelligence organizations and brigade S2s is critical.

The follow and support division commander's PIR are the size and location of enemy forces observed by the lead divisions and enemy potential to disrupt lead division operations from the flanks. The infantry division staff reviews the lead division's PIR to see if they apply to the follow and support mission. Upon recommendation from his staff, the follow and support division commander identifies his PIR.

The division G2 and MI battalion commander use these PIR to develop the division collection plan and to allocate intelligence resources. Only intelligence assets and systems necessary for the follow and support mission are used. Each brigade has a MI team to support intelligence operations.

Division MI assets focus on the division's flanks. They concentrate on potential enemy counterattacks along identified avenues of approach, and enemy reinforcement of forces already observed and engaged. Quickfix is in GS to the division to provide early warning on enemy movement along the flanks. The division G2 integrates EW jamming and collection assets into attack plans of the brigades to disrupt enemy C² and locate enemy elements.

Fire Support

Fire support is used to neutralize, fix, or destroy pockets of resistance prior to direct fire engagement by the infantry when possible. The division has limited organic artillery assets. In this example, a FA brigade reinforces the DIVARTY. Each brigade has a 105-millimeter artillery battalion in direct support. The DIVARTY controls the fires and positioning of the general support artillery battery and corps FA brigade. DIVARTY-controlled artillery units move behind the lead maneuver brigade to provide additional fire support as required (see Figure 3-39, page 3-42). The division FSE integrates CAS and EW into brigade operations.

The lead division's fire support measures remain in effect until the boundaries of the follow and support brigade are established. Brigade and division fire support measures are put in effect when elements of the lead infantry brigade relieve the fixing unit. The infantry division FSE and DIVARTY continually update fire support measures during the follow and support mission. The infantry division FSE continually reviews the positioning of GS artillery to provide massed fire support at critical times and locations.

DIVARTY positions counter mortar and counterbattery radars and assigns radars sectors of search. It assigns Quickfire channels to artillery units covering those sectors with priority to units initially committed to a mission.

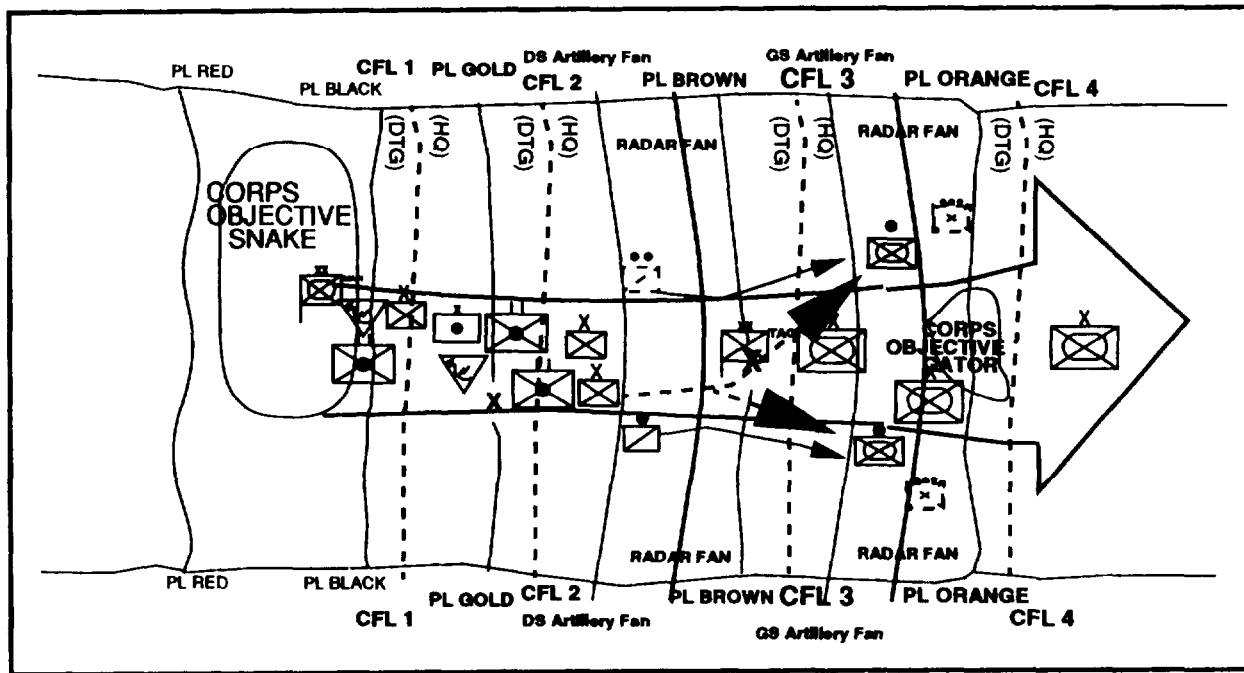

Figure 3-39. Follow and support concept of operations: fire support

Mobility and Survivability

Engineer assets are in DS of brigades. They give each brigade a limited breaching capability. Priority of effort is to mobility. Coordination with the forward division identifies obstacles and the need for road repairs.

Division engineers plan situational obstacles on likely enemy avenues of attack. The division engineer coordinates FASCAM targets with the FSE, G2, and G3 to isolate by-passed units.

Air Defense Artillery

Direct support ADA assets provide protective umbrellas to the brigades while general support ADA protects critical division locations. Each brigade has limited ADA. Most ADA assets are under division control. These are positioned on potential enemy air avenues of approach and around friendly HPTs such as the TAC CP, main CP, MSR, and brigade CPs. The priority of effort is to protect key areas where attack would disrupt the corps operation. The lead division and corps provides enemy air IPB.

Combat Service Support

Division CSS (Figure 3-40) must be mobile and continuous during the movement. In this

example, the lead division identified two MSR for the follow and support division. The division rear CP controls movement on these MSR (in coordination with the main CP). Tailored FSB units move with their brigade. Remaining FSB elements move on order as the brigade areas are established. The TAC or main CP assigns priority of support on a situational basis.

Brigades tailor their combat loads based on the factors of METT-T. Nonessential CSS assets remain with the FSB. The G4 and G3 ensure CSS units use movement windows to push supplies forward to FSBs. Casualties are evacuated as expeditiously as possible by both ground and air assets. The DISCOM and remaining division troops move forward on order.

Command and Control

The division TAC CP establishes control measures with the lead division to unify their efforts. The infantry division provides a liaison team to the lead division main CP to maintain continuous contact and facilitate this effort. The TAC CP moves with the lead brigade of the division. This strengthens communications with the lead division main CP. The infantry main CP and the rear CP move on order.

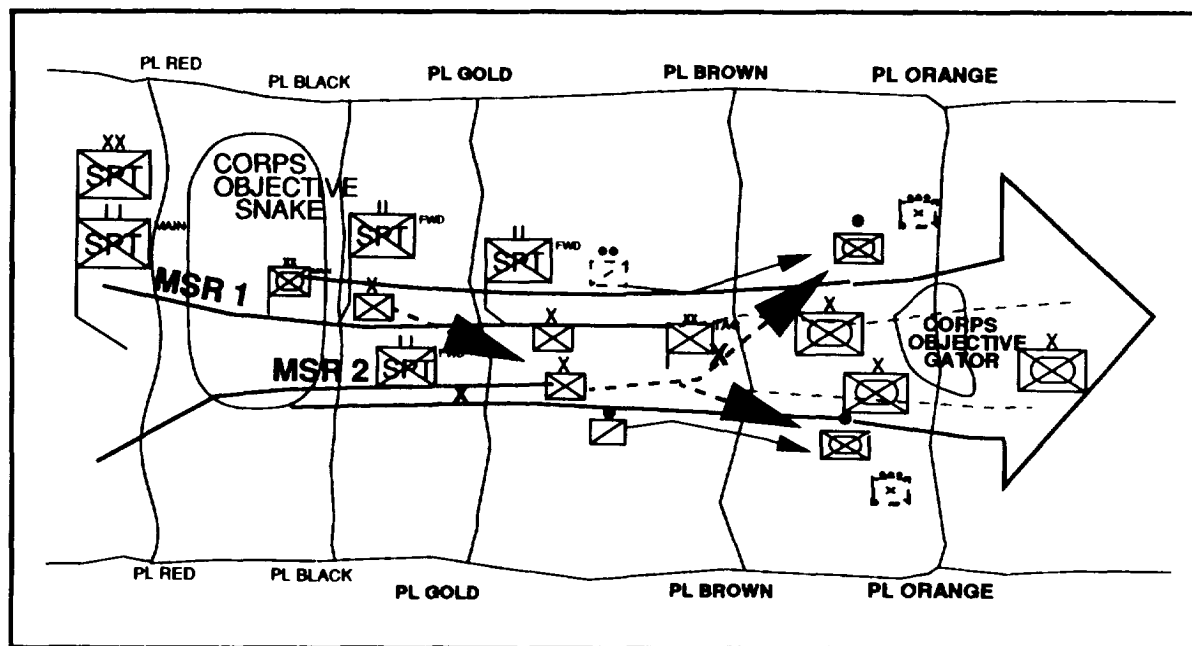

Figure 3-40. Follow and support concept of operations: combat service support

As lead division units bypass pockets of enemy resistance, the lead division tasks the infantry division TAC CP to eliminate these enemy forces. The TAC CP coordinates the battle handoff between the observing lead division unit and the lead brigade of the infantry division. The reconnaissance squadron coordinates with the observing unit and identifies routes and measures to aid in linkup. The TAC continues forward with the lead brigade of the division as it moves forward and commits units.

Once the division establishes a brigade AO, control of that brigade passes to the main CP. The rear CP controls and prioritizes sustainment along division MSRs. It also performs terrain management in the division rear area. As the division moves forward, the rear CP coordinates and prioritizes sustainment along routes within the division's AO.

TRANSITION TO THE OFFENSE

If friendly defense is successful, the enemy reaches a culminating point within the main battle area (MBA); that is, the combat power of the

attacking enemy at the point of his attack no longer exceeds that of the friendly defender. The enemy attack has floundered and the enemy is transitioning to a defense.

During this transition period, time becomes critical. The friendly force commander must already have a plan to attack quickly. He rapidly reorganizes, refits selected units, moves to attack positions, and attacks. Unless moved, friendly MBA units will be in positions known to the enemy and subject to the enemy's artillery. Time is critical to the enemy also. He uses this time to reorganize, establish a security zone, and dig in his defensive positions.

Unless the friendly commander has a large, uncommitted reserve prepared to quickly exploit the situation, he must reset his defense and maintain contact with the enemy. At the same time, he must move forces to prepare for his attack or conduct a frontal attack with units in contact (normally the least favorable COA). Successful friendly force commanders must think through this transition period and have a plan to execute.

INFANTRY DIVISION DEFENSE

This chapter provides some examples of how infantry divisions integrate and synchronize combat, CS, and CSS assets for defensive operations. Corps, divisions, and brigades use a variety of tactics and techniques to execute a defense. The tactics and techniques discussed in this chapter describe only one way a division may conduct these operations.

TYPES OF DEFENSE

The defense is a temporary measure adopted until the division can resume or assume the offense. Defense as a form of warfare does not directly produce decisive victory. Therefore, the defense must be conducted aggressively to wrest the initiative from the attacker. The commander can accomplish this by mixing defensive and offensive tasks in his defensive concept of operations. Each concept of the operation must clearly identify how to seize the initiative through a defeat mechanism. The concept must also envision a sequel to maintain the initiative and exploit tactical successes.

The defense may be one battle or a series executed over time. Subordinate units are given defensive tasks to contain or trap an enemy force, deny area access, attrit the enemy, or act as an economy of force. Others are given tasks to attack or counterattack. The intent is to achieve conditions to gain and maintain the initiative for decisive offensive action. Without a compelling reason to defend, we attack.

There are two forms of defense—mobile and area. The mobile defense aims to destroy enemy forces through a decisive counterattack. It is more lethal since it concentrates the bulk of combat power upon the enemy force, producing a decisive result. It requires a large mobile counterattack force, the capability to mass overwhelming fires, adequate maneuver area in depth, and at least air parity with an effective air defense. The mobile defender must have the freedom and capability to maneuver.

The area defense usually orients on retention of terrain. Forces are deployed laterally and in depth, retaining terrain rather than focusing on the enemy. When defending against armored forces in close terrain, area defenses are normally

situated to defend on high speed avenues of approach. Area defenses are best in rough terrain, or when specific terrain must be retained, the sector lacks depth, or the defender lacks sufficient maneuver potential compared to the enemy. When operating independently, in the jungle or when encircled, units may find themselves in a perimeter defense. (See example in Chapter 8.)

See page 3-2 for guidance on the current chemical and nuclear weapons policy.

FUNDAMENTALS

All defenses must use terrain properly. Terrain is a force multiplier for infantry units. It facilitates massing combat power at the point of decision by allowing smaller forces to defend restrictive terrain elsewhere. Terrain, reinforced by barriers, influences enemy movements and tempo for exploitation. It degrades enemy maneuver and can fix him for effective attack. Terrain also provides cover and concealment for the defender.

All defenses must conduct security operations. The defender has the advantage of terrain, but initially lacks the initiative. Defenders accept risk in economy of force areas in order to mass for combat power elsewhere. Security operations prevent surprise and reduce the risk of bypass or encirclement of the main effort.

Defense in depth provides flexibility and dispersion to the defender while reducing risk. Deployment in depth provides time to assess and react to changes on the battlefield once the battle begins. Defense in depth facilitates—

- Shifting of forces.
- Employment of counterattacks.
- Use of engagement areas, barriers, and improved positions to canalize, delay, or attrit in depth.

- Attack of the enemy's flanks and rear.
- Deception plans.

Mutual support integrates the fires of the total force. It allows a dispersed force but focuses combat power.

The infantry division is a tactically mobile force with respect to terrain. It lacks maneuver speed potential unless it fights an enemy with equal or less maneuver capability. The division can defend successfully in close terrain against mechanized or motorized forces when properly augmented with antiarmor or mechanized forces. The division may be part of a corps defense to act as an anchor, allowing other divisions to concentrate for a counterattack or envelopment. As a pure infantry division, it can conduct an area defense in appropriate terrain to block dismounted enemy movements. It can also defend against an enemy infantry armored force with small organic tank units.

Examples in this chapter discuss both area and mobile defenses. The mobile defense in warfare is not a viable mission for light divisions without aviation, anti armor, transportation, and armored augmentation. An armored brigade in support of a light division constitutes a *light-armored operation*, discussed in Chapter 7. Only the air assault division can conduct mobile defense operations without augmentation.

The defeat mechanism for armored attacks is a combination of artillery, attack helicopters, USAF aircraft, integrated obstacle plans, and the division's medium and heavy antitank systems. Against enemy infantry forces, the defeat mechanism is artillery, mortars, air support, and infantry.

DEFENSE IN SECTOR: TERRAIN RETENTION

In this example, the corps defends with one infantry division and one armored division abreast and an armored cavalry regiment covering force. It has a separate mechanized brigade in reserve. The corps is defending against part of an enemy corps.

The enemy corps is a secondary effort. It is expected to attack in the friendly corps sector

with four infantry divisions, one mechanized infantry brigade, and one armored regiment.

Terrain in the corps sector is restrictive with narrow valleys and numerous small built-up areas. Vehicle traffic is mostly restricted to improved roads and a few wide areas in the valleys. The terrain generally allows more maneuver in the armored division's defensive sector. The infantry division's defensive sector is in the northern half of the corps sector (see Figure 4-1). The infantry division has been given a defensive sector dominated by high rugged hills and a small built-up area. One improved highway runs the length of the sector. The infantry division has the mission to defend in sector.

The corps commander intends to anchor his defense with infantry on his left defending in restrictive terrain. The corps armored division defends in depth on the right. The armored cavalry regiment (ACR) is the corps covering force. The corps reserve (a separate armored brigade) is positioned behind the armored division.

The cavalry regiment moves to a corps assembly area after the covering force fight. The corps commander wants to defeat the enemy's attack forward of PL DOG and then counterattack with his separate mechanized brigade to destroy remaining enemy formations in zone and restore the FEBA.

Corps deep operations initially focus on distant, uncommitted enemy forces. Deep operations target any mechanized or armored units moving forward to exploit penetrations. The remainder of this section discusses the specific operations of the infantry division defense in sector (terrain retention).

Maneuver

The infantry division defends in sector with three brigades on line along PL DOG. (See Figure 4-2, page 4-4.) The division commander retains one infantry battalion as division reserve. The main effort is in the south where potential for an enemy mechanized force exploitation exists. The enemy is expected to try to infiltrate around built-up areas. An enemy supporting attack is expected in the north. The division's task organization for this example is provided at Figure 4-3, page 4-5. This division is the corps' supporting effort.

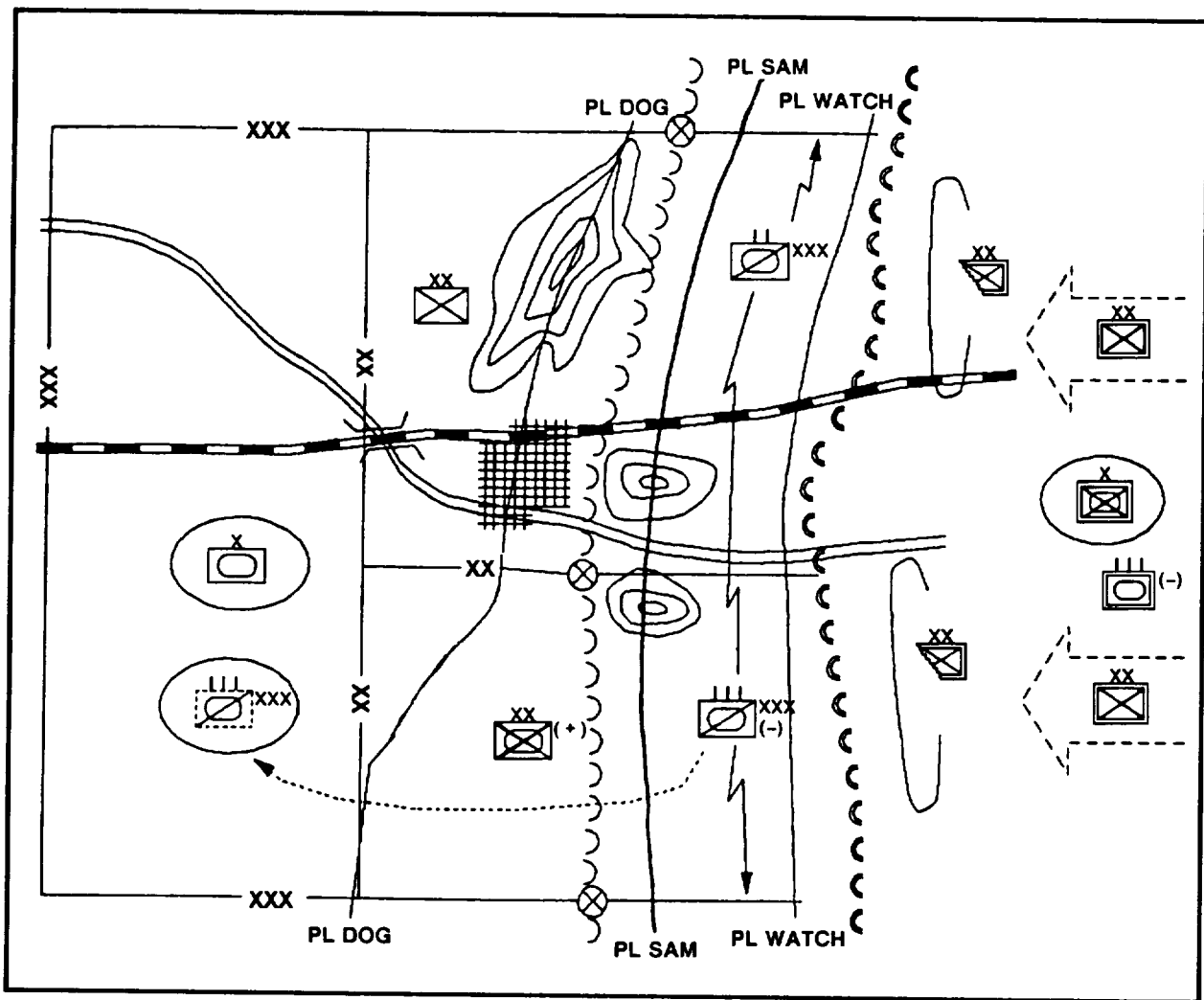

Figure 4-1. Corps situation

Therefore, its share of corps supporting units is small.

Deep Operations

The division must initially find and target enemy artillery units—the greatest threat to infantry units' freedom of maneuver. The proactive counterfire operation as a deep operation is defined by target type, not distance from the FLOT or relative location with respect to a phase line.

Deep operations can alter the combat power ratio for current and subsequent close operations by destroying artillery, attriting infantry formations, and desynchronizing the enemy's attempt to mass. Attacking enemy divisions are echeloned

in depth as they approach the FEBA. Leading enemy regiments, the division's close fight, are engaged by brigades. Follow-on enemy regiments and reserves are division deep targets. The corps attacks other enemy divisions as the enemy moves forward.

To delineate deep attack responsibilities for these ground maneuver targets, the corps and division specify phase lines which separate their close and deep operations areas. The phase line creates a point where handoff coordination is accomplished between echelons. It does not create separate areas where uncoordinated concepts of the operation are executed. The maneuver concept of the operation, intent, and deep operations' desired results between the higher

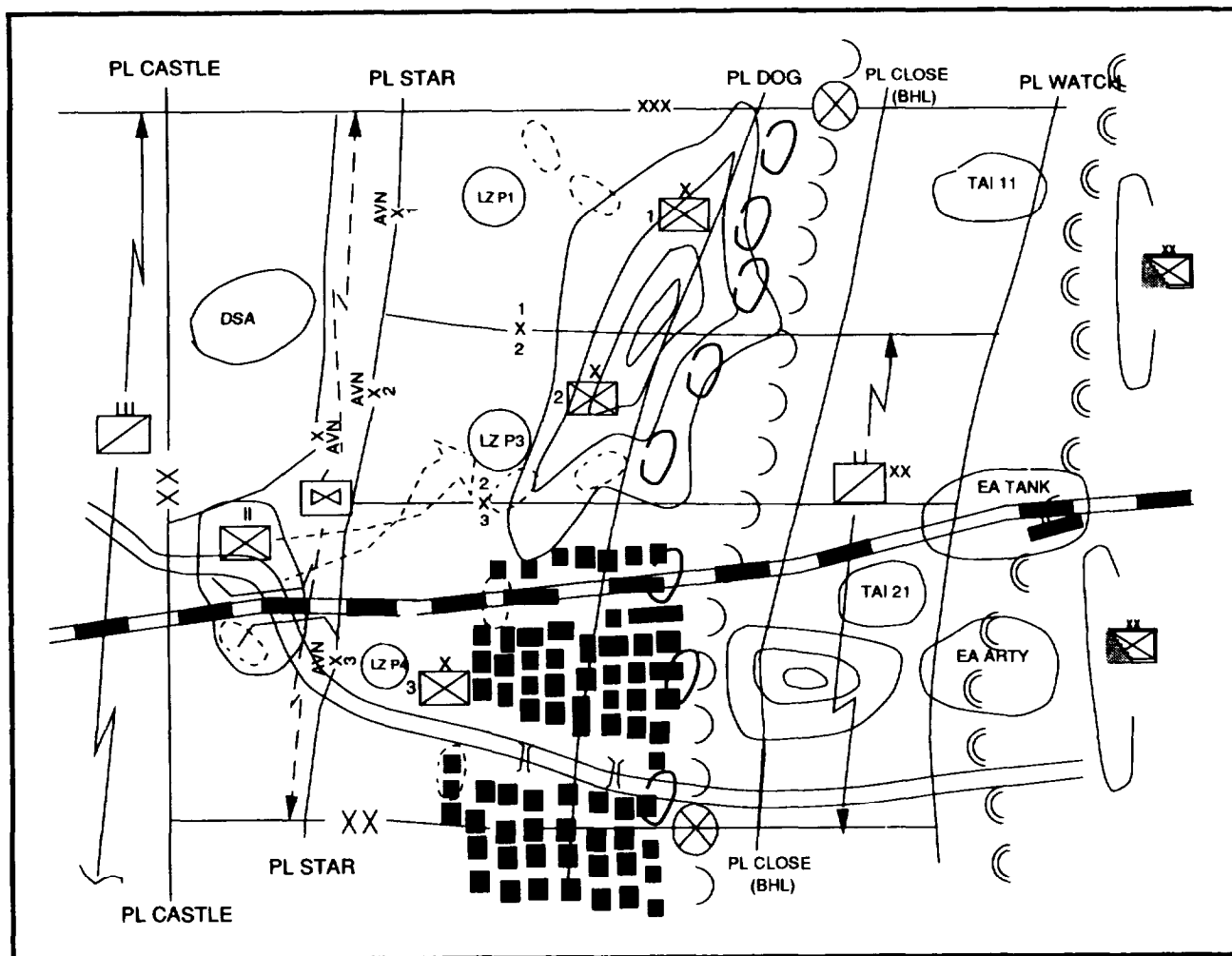

Figure 4-2. Maneuver: concept of operation

and lower commanders are coordinated and mutually supporting. The senior commander specifies his intent for the deep operation in his OPOD. The subordinate commander supports this intent and coordinates his concept, intent, and desired effects with the senior commander in the backbrief or rehearsal. Coordination of deep operations handoff and synchronization of intent are required at the specified phase. This is especially true for intelligence collection and targeting.

The division commander has reserved proactive counterfire for the deep operation. He has reserved enemy artillery units as a specified target type. These enemy artillery units are targeted and attacked anywhere on the battlefield—

regardless of the specified phase line for moving enemy infantry or armored units.

The primary division deep weapon systems are MLRS (if available), tube artillery, fixed-wing AI, and attack helicopters. These are division assets or corps-provided support.

Close Operations

Close operations are fought with mutually supporting positions and integrated obstacles constructed in depth. Infantry operations must contain enemy infantry movements so that they can be engaged with massed artillery and mortar fire. Attack helicopters and CAS augment these fires. Attack helicopters and CAS counter enemy armored forces, especially when massed

<i>1st Bde</i>	<i>2d Bde</i>	<i>3d Bde</i>
Inf Bn	Inf Bn	Inf Bn
Inf Bn	Inf Bn	Inf Bn
Inf Bn		Inf Bn
FA Bn (105T) (DS)	FA Bn (105T) (DS)	FA Bn (105T) (DS)
FA Bn (155T) (R)	FA Btry (155T) (R)	FA Bn (155T) (R)
Engr Bn Cbt (W) (-) DS	Engr Co (Lt)	Engr Bn Cbt (M) (DS)
Engr Co (-) (Lt)	Plt Engr Co (o/o Atchd to Div Reserve)	Engr Co (Lt)
FSB		CBT Engr Co (W)
Btry/ADA Bn (V/S) (-) (DS)	FSB	FSB
GSR Sqd	Plt/A Btry/ADA Bn (V/S) (DS)	Btry/ADA Bn (V/S) (-) (DS)
Chem Plt (Smk Decon) (DS)	GSR Sqd	Interrogation Tm (DS)
Interrogation Tm (DS)	Interrogation Tm (DS)	GSR Plt (-)/I&S Plt MI Bn
PSYOP Team	PSYOP Team	Chem Plt (Smk Decon) (DS)
CA Team	CA Team	PSYOP Team
		CA Team
<i>DIVARTY</i>	<i>Avn Bde</i>	<i>Division Troops</i>
Corps TAD Det	Atk Bn	Inf Bn (Reserve)
MLRS Bn (GS)	CAC	Lt Cav Sqdn
FA Bn (155SP) (GSR 3d Bde) (DS Bn)	CAC	Stinger Section/B Btry (DS, o/o attached to Div Reserve) GSR Sqd
	Atk Bn/xxx (OPCON)	MP Co (xx)
<i>DISCOM</i>		Div Band
MSB		Combat Support Co (-) (xxx)
Med Truck Co		ADA Bn (-) (GS)
CA Co (-)/xxx		Radar Maint Plt
		Radar Maint Plt
		Sig Bn
		MI Bn (-)
		Div Engr Bn (-)
		Engr Gp (GS)
		Engr Bn Cbt (SCW)/xxx
		Engr Co (CSE)/xxx
		PSYOP Co (-)/xxx
		Chem Co (Smk Decon)/xxx
		(-) (GS)

Figure 4.3. Division task organization

formations are deployed to exploit success. Enemy tanks are expected to be used principally as infantry fire support due to limited maneuver space. Brigades position TOWs and Dragons to destroy tanks supporting infantry attacks. Since tank and mechanized units are committed to exploit penetrations, antiarmor fires are planned in depth.

Area defense focused on terrain retention relies upon using terrain, obstacles, and massed fires to stop and kill an attacking enemy. Fires in

depth desynchronize the enemy attack plan, but success is achieved by overwhelming massed fires at the FLOT.

Because the infantry division will probably not have sufficient mobility to move faster than an attacking enemy, the initial defense at the FLOT is crucial. Thorough reconnaissance to situate the defense is critical. Any repositioning of units to alternate or supplementary positions must be completed prior to the arrival of enemy main body or preparation fires. These moves are

triggered by events collected by the deep intelligence operations. A decision support template must be developed and used.

This type of defense may be considered high risk since it orients on retaining terrain. Risk can only be minimized by allowing the maximum possible depth for defense in front of the retained terrain. Massed fires must be used in conjunction with obstacles to create engagement areas (EAs) which deny momentum and initiative to the enemy. Obstacles cause the enemy to mass and thereby increase the effectiveness of fires.

Rear Operations

The division cavalry squadron initially screens forward of the line of contact behind PL WATCH. On withdrawal, it rejoins the aviation brigade to screen behind committed brigades to locate infiltrating and penetrating enemy units. On order, it defends to block or contain the enemy so that the enemy can be attacked by fires.

Division CS and CSS units locate in mutually supporting base clusters. Each must establish credible defenses against infiltrating enemy infantry units. Support units locate away from routes suitable for enemy mechanized or armored exploitation. Division CSS elements which cannot be adequately protected locate in the corps rear area.

Security Operations

The corps armored cavalry regiment conducts covering force operations forward of PL WATCH until withdrawn. Initially, the division cavalry squadron screens forward of the main effort, behind PL WATCH. Division tasks the brigade in the north to screen forward along PL WATCH. The mission is to screen since the light division cannot deploy a suitable covering force. This screening force lacks sufficient size, strength, and ground maneuver capability to prevent its being decisively engaged or bypassed by large infantry forces. Therefore, a screen is established for early warning first and attrition second. Artillery fires and CAS are planned to attrit, disrupt tempo, and support the covering forces' retrograde operation.

The northern brigade defends in rough terrain where dismounted movement is the norm. The division directs the brigade to conduct its own

screen. The division cavalry squadron conducts its screen in the center and south where the terrain, though rough, allows more movement by large units and vehicles. The screen mission includes counterreconnaissance to detect and destroy enemy reconnaissance units within the squadron's capabilities. The division cavalry squadron concentrates its effort forward of the division's main effort, the 3d brigade. This sector has the most favorable enemy avenues of approach in the division sector. If employed against the division, the enemy armored attack would be expected in the 3d brigade area attempting to bypass the city to the north.

The battle handoff line for the screening force is PL CLOSE. The defending brigades send out security elements as far out PL CLOSE. They must mark routes and provide fire support for the retrograde. The handoff line partially defines the division's forward security area.

The enemy can be expected to attempt infiltrations in support of every attack to bypass or penetrate the main defenses and attack friendly reserves, C², and CSS elements. Friendly security operations include combinations of OPs, patrols, and surveillance systems. Maneuver brigades secure the division flanks in sector.

After withdrawal from the screening mission, the division cavalry squadron rejoins the aviation brigade in the aviation brigade sector. The aviation brigade performs security operations behind the brigades. The mission is to discover and contain or block enemy infiltrations or penetrations into the division rear area. In this scenario, the enemy executes infiltration and bypasses resistance in every attack. The aviation brigade was given this security mission because it controls the division cavalry squadron. The division intent is to employ attack helicopters in support of the brigades and the deep operation.

Reserve Operations

It is difficult for an infantry division to maintain a large reserve in this mission. The division reserve must have a dedicated movement capability, either organic or provided, to react in a timely manner.

In this example, the division has one infantry battalion in reserve and dedicated lift assets.

Movement of reserves must be planned carefully due to vulnerability to indirect fires and air attack while moving. Selected reinforcement routes should provide cover and concealment while rear area security and reconnaissance operations decrease the probability of enemy stay-behind or special forces observing reserve locations. Electronic warfare or fires directed at enemy C² or fire control HQ can degrade the enemy's ability to attack the reserve. Finally, artillery and smoke fires may be required to cover reserve deployment and employment.

Intelligence

Military intelligence assets are deployed forward in brigade areas to range beyond the FLOT. The collection company is normally task-organized into three teams. These teams control voice and signal intelligence (SIGINT) collection for the division. In this example, one platoon-sized team supports the secondary-effort brigade and the company (-) supports division main-effort brigade. One ground surveillance radar (GSR) squad is attached to each brigade. The fourth GSR squad is attached to the cavalry squadron and initially supports the cavalry screening force and then the rear area screen. The GSRs orient on supporting brigade operations by detecting enemy infantry infiltrations.

The LRSDs are deployed to observe NAIs, TAIs, or decision points (DPs) for targeting purposes. Intelligence collection tasks and guidance are planned and prepared by division G2 based upon the G3's guidance.

The LRSD teams are deployed by the G3. Teams are deployed with the cavalry screening force and infiltrate to assigned dispersal areas. Teams select positions that provide long-range observation of assigned areas.

The remainder of the interrogation and surveillance (I&S) company is located at the division EPW collection point.

The division G2 coordinates intelligence handoff for enemy units from corps to division and division to brigade. Enemy units, NAIs, and TAIs are observed and monitored according to the priorities established in the collection plan. Division G2 at the TAC CP tracks enemy units into brigade AOs for targeting and situation develop-

ment purposes. In this example, PIR collection requirements are in order of priority.

- Location and movements of enemy artillery units.
- Location and movement of follow-on divisions.
- Location and movement of enemy armored or mechanized forces.
- Location of enemy division-level C² facilities.

Fire Support

Artillery, EW, and TACAIR support are organized to provide massed fire support to defeat enemy attacks in both the main and supporting efforts areas. Artillery support is weighted to the main effort. Corps MLRS and 155-millimeter SP battalions can be positioned to support the main effort area.

The division establishes PL WATCH as a coordinated fire line (CFL) while the division cavalry squadron is forward. After withdrawal, PL CLOSE becomes the division CFL. The corps fire support coordinated line (FSCL) is then moved to PL COLLAR from PL TURTLE. (See Figure 4-4.)

The division establishes EA TANK as the best location for a joint air attack team (JAAT) or CAS attack on enemy armored forces before they reach brigade areas of operations. The division establishes TAI 11 and TAI 21 from terrain analysis as likely areas for enemy infantry units to occupy or move through to their LD. The EAs TUBE and ARTY are likely artillery firing position areas.

The IPB indicates specific terrain the enemy may use but intelligence collection operations must confirm or deny enemy movements prior to or early in the battle. The targeting handoff from corps to division must clearly indicate enemy lines of operation two echelons down. The LRSDs are the best means to target infantry units moving through rough terrain with cover and concealment. Sensors are used to augment LRSD efforts, G3 establishes "no fire" areas around LRSDs.

Mobility and Survivability

Obstacle zones are specified by division to influence enemy tempo by turning, blocking, disrupting, or fixing enemy formations as part of the maneuver. The commander specifies any

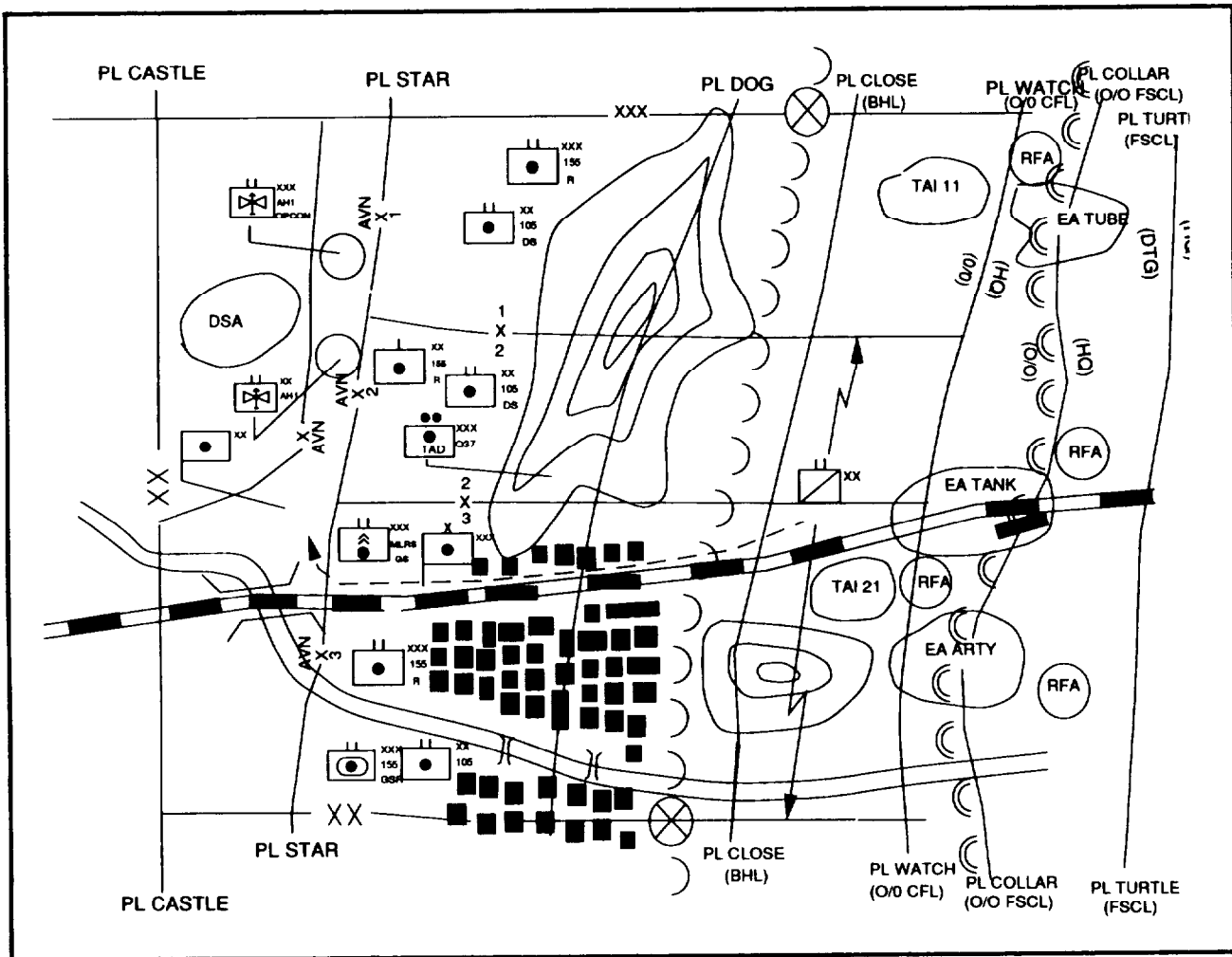

Figure 4.4. Defense in sector: fire support

obstacle-restricted areas. Brigade commanders plan obstacle belts to support the division commander's concept.

Obstacle zones are drawn to give maximum flexibility to subordinate commanders and to facilitate future operations. Obstacles forward of the battle hand-over line (BHL) facilitate the battle handoff.

In this example, the engineers are task-organized with armored-light engineer mixes in the 1st brigade (north) sector and in the 3d brigade (south) sector. (See Figure 4-5.) The 3d brigade has one reinforced corps wheeled engineer battalion and a light engineer company. This brigade, as the main effort, has the most engineer

work to execute. It receives priority of division engineer support from the CS equipment company and the one combined engineer battalion.

The 1st brigade, as a supporting effort, is supported by one corps engineer wheeled battalion and a light engineer company (-). The 2d brigade, in the center, has a light engineer company plus one light platoon from the engineer company with the 1st brigade. This platoon has an on-order mission for attachment to the division reserve infantry battalion.

Priority of effort in the division's close operation is countermobility, survivability, and then mobility. Behind the division engineer work line to the division rear, the priority of effort is to

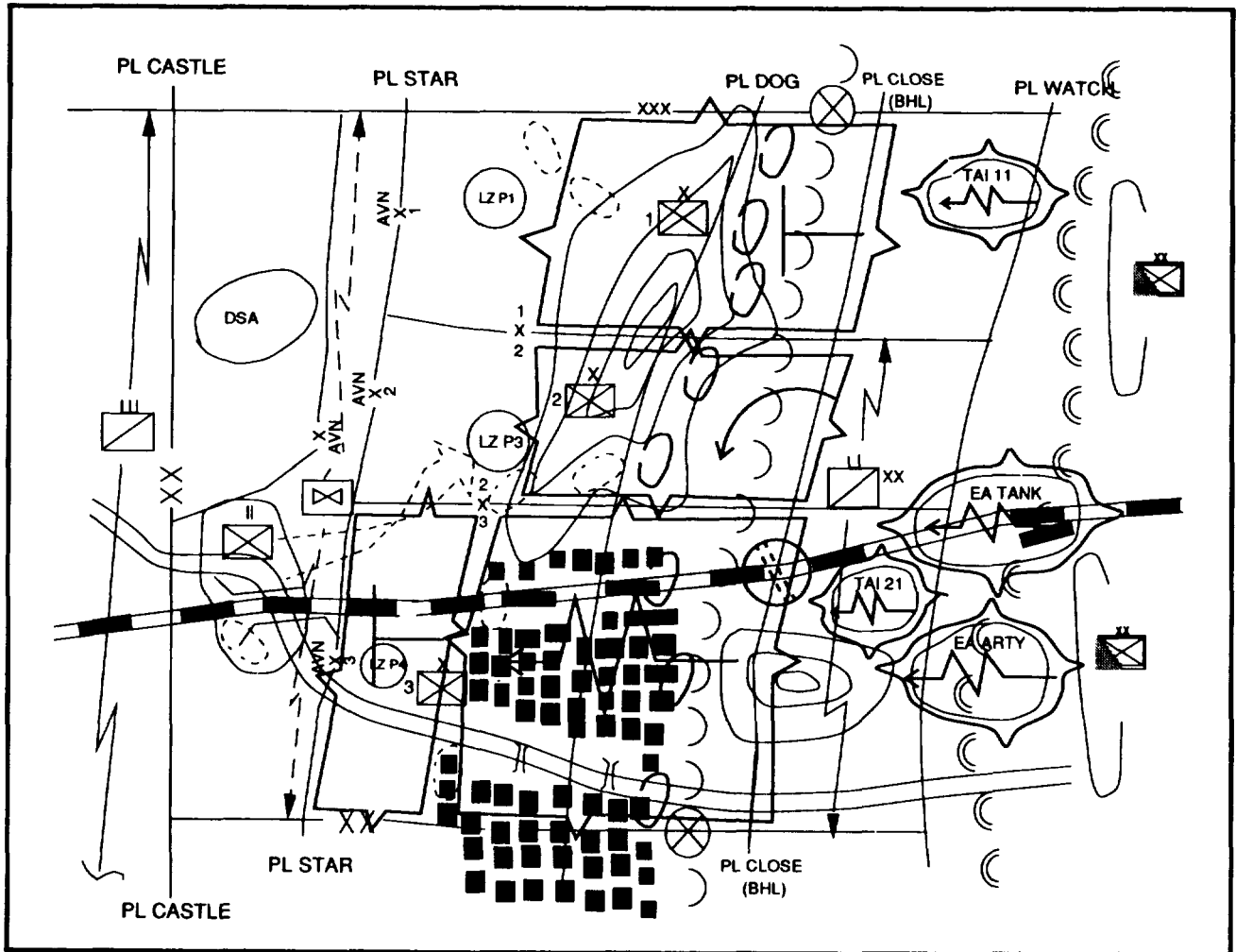

Figure 4-5. Defense in sector: mobility and survivability

mobility to facilitate movement, and then survivability.

Priority of support forward of PL STAR is to the 3d, 1st, and 2d brigades and then to the DIVARTY. Priority of support behind PL STAR is to the aviation brigade, DISCOM, and then the reserve.

The division commander has designated turn, block, and fix obstacle areas for his brigade commanders. (NOTE: No disrupt obstacle areas were specified in this scenario.) These areas graphically convey the division commander's intent for tempo and maneuver. The brigades establish turn, block, fix, or disrupt obstacles as needed. The total effect of their zones must satisfy the in-

tent required by the division commander's obstacle area.

Fixing areas have been placed at the trailing edge of EAs or TAIs to hold enemy forces and increase their vulnerability to deep attack. A turning area and reserve target have been specified for the one hard-surfaced road or armored approach. The division commander wants to influence the enemy to move into the built-up area and away from the economy of force brigade. One large blocking area is specified along PL DOG to stop the enemy short of PL DOG. A second line of defenses is established in the 1st and 3d brigade areas forward of PL STAR. These must contain enemy penetrations. Obstacle free areas (OFAs)

are specified to cover planned LZs for the division reserve.

Situational obstacles include ground and air-emplaced FASCAM. Both the division and brigades may use these obstacles (if release authority is granted) to react to unexpected enemy initiatives as the battle unfolds. Control of situational obstacle assets can be retained at division, passed to subordinate units for planning, or delegated to subordinate units. Situational obstacles are reflected on the division support template (DST). The G3, engineer, and assistant fire support coordinator (AFSCOORD) develop FASCAM class V requirements during COA wargaming. Obstacle areas to the rear of PL CASTLE (the engineer work line) are for subsequent positions to contain enemy tactical successes. The two areas between PL DOG and PL STAR provide defense in depth. These areas are planned to support the division-level maneuver and tempo concept for both friendly and enemy units.

Maneuver, tempo, and fires are partially synchronized by the obstacle plan according to the commander's intent. The expression of this intent is a C² and maneuver BOS action. The execution is the M/S BOS action. Obstacles are not an engineer only issue. Obstacle areas and targets are based on maneuver concepts.

Air Defense

The division's main effort is the 3d brigade in the south. It is supported by battery B (-). One of its Stinger sections is initially in DS to the cavalry screening force and, on order, is attached to the division reserve battalion. The 1st brigade, as a supporting effort, is supported by battery A (-) in a DS role. One task-organized Avenger/Vulcan/Stinger platoon from battery A is DS to the 2d brigade. One Stinger section from battery A is OPCON to DIVARTY.

Avenger systems and the majority of the Stinger sections are located well forward in the brigade areas. Stingers counter enemy CAS and attack helicopter operations at the FLOT. (Vulcan guns also engage enemy attack helicopters.)

Stinger teams are also provided to critical assets such as reserve artillery radars, or supporting MLRS. Other critical assets such as the DSA

or attack helicopter staging areas are placed deep in the division rear area. Because they lack supporting organic ADA support, these units must rely on overlapping incidental corps ADA coverage, passive air defense measures, and counterair operations for protection against enemy air attack threats.

In this example, the enemy has three routes into the sector for air support and attack helicopters. If an air threat to the division rear develops from the flank, the corps ADA brigade must adjust coverage or provide additional assets to the division. Enemy CAS and attack helicopters, directed at the FLOT, remain the most significant air threat to the defense in this scenario.

Combat Service Support

The DISCOM HQ, MSB, and corps-attached or OPCON support units are located in the DSA. Units may be tightly clustered when the enemy poses a significant special operations or infiltration threat or more widely dispersed when the threat potential is lower. Supply distribution will be throughput where possible.

Corps support units, such as medical and class V, may be located in the division rear area. They provide area support to the division and other corps units in the division AOs.

The FSBs are located in the brigade rear areas in the vicinity of specified MSRs and SRs. (See Figure 4-6.) In the defense, FSBs stockpile large quantities of class I, V, and VII on pallets or trailers in the BSAs. Further ground stocks of class I, IV, and V are sited in the battalion area. Consumption of small arms munitions in the terrain retention battle will be high. Resupply will be difficult during the fight due to the terrain and enemy. To facilitate resupply, stockpiles are sited prior to the fight.

Resupply by vehicle may be difficult due to terrain and limited road networks. Resupply by air, using prepackaged push packages, to unit supply points will be the norm. Landing zones must be established for this purpose.

These LZs also serve as medical patient collection points or ambulance exchange points for medical evacuation. They should be close to road

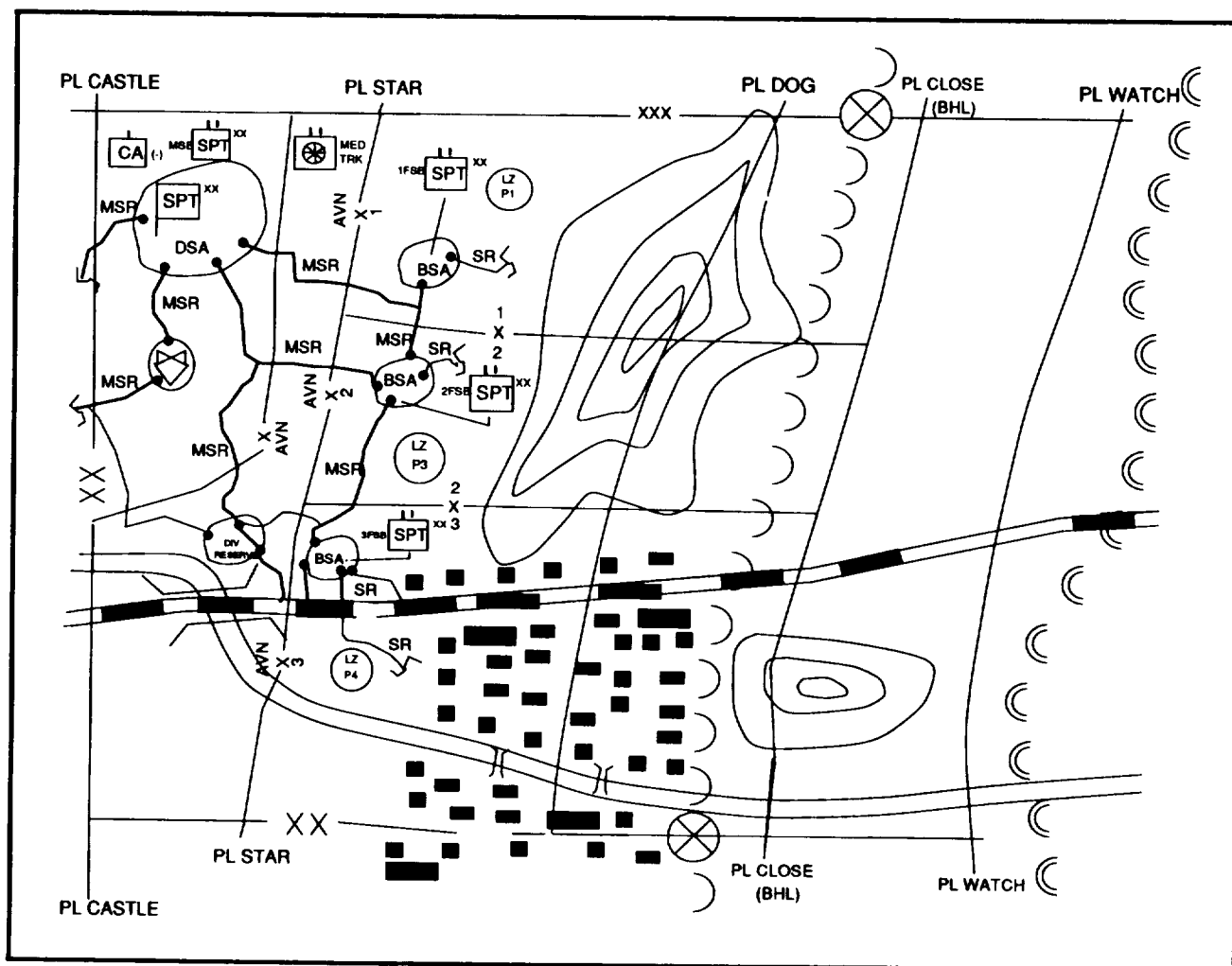

Figure 4-6. Defense in sector: combat service support

networks so resupply and evacuation can continue despite the weather or enemy actions. Aeromedical evacuation planning and coordinating is required for this type of environment. In this example, a mobile Army surgical hospital is located in the division rear area near MSRs. Corps also provides additional air and ground ambulance assets.

Maintenance teams in the MSB and FSBs go forward to repair weapons systems and vehicles that can be quickly returned to operation by use of quick-change assemblies or small parts. Extensive repair work is evacuated to the MSB in the DSA or directly to corps. When possible, maintenance floats are issued to maintain maximum

combat power. Evacuation of nonrepairable weapons and vehicles is to the BSAs.

The DISCOM establishes and monitors road movement in the division rear. The repair forward concept and air resupply were considered when developing this plan since the terrain offers few roads. Road use is tightly controlled to support the division's concept of operations. Although strict, the plan allows for vehicle infiltrations for C², signal, medical, and engineer purposes.

Container delivery system techniques using tactical airlift (C130 aircraft) or heavy-lift helicopter supports allow for steady CSS flow.

The division G4 develops a road network to support CSS operations and coordinates this with

the G3 for tactical movement route requirements. The G4 develops a traffic circulation and control plan and sustainment construction list for roads, helipads, and airfields. The G3 approves this plan and the G4 coordinates it with the DISCOM, PM, and supporting corps engineers. Necessary helipad and road upgrade, repair, or construction are begun as early as possible.

Nuclear, Biological, and Chemical

In this example, one corps smoke-decontamination chemical company is attached to the light division for the defense. The enemy is expected to use artillery and rocket-delivered chemical munitions. The NBC priority, therefore, is decontamination. Four dual purpose platoons provide deliberate decontamination support from established sites. Two dual-purpose platoons in DS support the 3d brigade's main effort. One platoon provides smoke and the other, decon. One dual-purpose platoon providing decon in DS supports the 1st brigade. One dual-purpose platoon and the chemical company (-) in the GS role supports the division rear. Alternate sites 2 and 11 are located to support decontamination operations if the enemy achieves contamination success in the division's main effort area or DSA.

These alternate sites are prepared as platoon sites for deliberate decontamination by the dual-purpose platoon in the division rear in the GS role. They may be operated by one chemical decontamination squad to support hasty decontamination operations. Infantry units are expected to conduct personal and hasty decontamination operations. They undergo deliberate decontamination when time and situation permit. Patient decontamination is performed by personnel from the supported unit at medical treatment facilities. Patient decontamination procedures are supervised by medical personnel while providing care to the casualties.

One chemical platoon is designated to provide smoke support in a DS role to the main effort. Smoke may be used to limit enemy target acquisition, conceal friendly movements, and support limited counterattacks in the built-up area. The brigade commander develops smoke support requirements and coordinates with the division and adjacent brigade commanders. Smoke requirements for the other brigades, DISCOM, aviation

elements, artillery, deception, and OPSEC are met with class V smoke pots. Smoke is also planned using artillery or mortar-delivered smoke munitions. The smoke plan should also consider smoke operations for OPSEC reasons.

Command and Control

The division TAC CP locates forward in the main effort area. Its location should be near the brigades' rear boundary and masked by terrain for OPSEC and deception. The TAC CP will not always locate with the main effort if the enemy has a significant SIGINT capability. From a position between the main effort and economy of force brigades, the TAC CP can control and support the main fight,

The main CP locates near the aviation brigade (the alternate division CP) and reserve where it can adequately support synchronization and concurrent operations activities, and deny enemy SIGINT collection. It is also beyond the range of most enemy artillery. Security against enemy infiltrations is enhanced by locating in or around the aviation brigade, division reserve, or corps engineer units.

The rear CP collocates with the DISCOM CP in the DSA. The DSA location is normally beyond the range of enemy artillery and multiple rocket launchers (MRLs),

MP Operations

The four MP platoons, three divisional and one corps, possess mobility, speed, and firepower. Their priority missions are rear area security, battlefield circulation control, and enemy prisoner of war operations.

The MPs are given area security and battlefield circulation control missions north of PL STAR from the division rear boundary forward to the brigade rear boundary. One platoon provides exterior security for the DSA by the use of screens, LPs, OPs, checkpoints and road blocks.

The MPs also have an area security and traffic circulation and control mission south of PL STAR from the division rear to the brigade rear boundary. The platoon assigned this mission provides an MP squad on order as a response force to the MP company HQ. This platoon also supports

the division reserve battalions' move to the brigade rear boundary.

Other platoons provide area security and battlefield circulation control from brigade rear boundaries to the battalion trains area. One platoon supports the main effort brigade while the other supports the other two brigades. Both platoons provide general support to the infantry brigades; artillery, engineers, and other CS units; and CSS units.

The MP platoons are under division control to support the division first on an area basis and then by mission request priority. Priority tasks are area security battlefield circulation control and then EPW operations. Priority of support is the main effort, artillery movements, DISCOM, other maneuver units, and other CS units. The division *reserve* becomes the first priority for support when committed.

The division band is attached to the MP company and operates the division EPW compound under the direct supervision of the MP company HQ.

Since this defense tends to be stationary, it is vulnerable. Deception and OPSEC are critical in preventing the enemy from accurately templating friendly defensive positions and intentions. Using dummy positions and manning alternate or supplementary positions will be necessary to confuse enemy targeting. Security, counter-reconnaissance, and smoke operations are needed to deny enemy direct observation. Additional measures to protect units and increase weapons effectiveness should be adopted as time permits. A stationary defense does not directly challenge the enemy's initiative until decisive combat has begun and should be used only when we can achieve a compelling advantage over the enemy.

DEFENSE IN SECTOR: DEFEND IN DEPTH TO DEFEAT ENEMY FORCE

The infantry division defends in depth to defeat enemy forces. This defense differs from terrain retention in that the mission focuses on the enemy force. Terrain within the sector is used to obtain an advantage, but retention of terrain is not the goal of the defense. The focus is on attriting the enemy through the depth of the

battlefield. As the defender, the infantry division retains some initiative in that it does not accept decisive engagement on a specified line. It accepts decisive combat when and where it supports destruction of the enemy force.

The division uses terrain reinforced by prepared positions and obstacles in depth to canalize the enemy into EAs. Direct fires and obstacles fix enemy forces for destruction by artillery, mortar, attack helicopter, and USAF fires. Decisive engagement between infantry forces is not the desired method for defeating the enemy. Decisive engagement is accepted only when needed to influence enemy movements.

The infantry division may defend against an armored force, an infantry force, or a force composed of varied levels of infantry and armored units. Many future enemies will likely have an infantry heavy base structure.

The infantry division defends in depth from prepared positions. Against armored units, these positions orient on the principal avenues of approach. The rough terrain canalizes the heavy forces on the roads, precluding enemy bypass or envelopment of the defensive positions. Alternate prepared positions compensate for different enemy courses of actions or unforeseen penetrations. The use of NAIs and DPs make possible long lead times for repositioning of forces prior to enemy contact. Once contact is made, repositioning units becomes difficult and risky. Against armored forces, repositioning is feasible only between prepared positions using helicopters. This requires a large engineer force and lengthy preparation time. Therefore, infantry units usually disperse to numerous prepared positions, seldom move after contact, and may be bypassed or isolated as a rule,

Against enemy infantry forces, the infantry may prepare strong forward defenses with reserves in a second line or in blocking positions. This is a classic linear defense tending toward heavy losses or disaster if ruptured or penetrated. If the enemy infantry force significantly outnumbered the defender, a defense in depth oriented on destruction of the enemy force maybe adopted. This defense in depth is also effective when the larger enemy infantry is supported by tanks.

These tanks are normally organic battalion units in the division or larger units from the corps or army.

The terrain should be restrictive to the degree that it canalizes the enemy's bulk of infantry units, CS, and CSS in valleys and passes. Blocking positions are established sometimes with smaller defensive positions. All gaps are covered with security operations with access to indirect or aerial fires. The enemy initially is destroyed by ground, artillery, and aerial fires throughout his depth on the enemy avenues of approach. Fires and alternate or supplementary positions are then used to destroy and block enemy infantry maneuver through the restrictive terrain to destroy our principal blocking positions. Movements between positions are minimized but must be planned to prevent subordinate units from being overrun and destroyed. These moves must be supported by counter fire, disengagement and movement fire plans. Movements are made by helicopter, tank, or tracks whenever possible.

In all cases, the enemy is allowed to move along designated avenues from EAs to EAs. Air and artillery fires are the primary killers, with division and brigade emphasizing massed fires such as time on target and JAAT missions.

The infantry division normally conducts this defense in terrain which affords infantry forces cover, concealment, and protection, but which also has open maneuver space for armored forces. Defensive positions are selected to force the enemy into EAs. Prepared positions around EAs fix enemy forces so that air and artillery fires can effectively engage them. Security forces cover gaps. As surviving enemy forces move into subsequent EAs, they are again taken under fire.

Final blocking positions are selected just forward of the brigade rear boundaries. Some key blocking positions may be designated as strongpoints. Selected engineer units may be reorganized as infantry if necessary for additional strongpoints to strengthen the defense.

The decision to use subsequent positions as well as the number of positions to use is based on the nature of the enemy force and the defender's mobility. A significant enemy armored threat dictates a defense in depth with minimum move-

ment between positions. Units prepare positions oriented *on* armored avenues of approach and use a comprehensive obstacle system to force the enemy force into an EA where it can be destroyed. A significant enemy infantry threat requires preparing positions in depth to counter a penetration. A defense in depth with movement to subsequent positions is favored when the enemy has an overwhelming infantry force advantage or significant infantry forces supported by armored units. It is similar to a delay operation, except that the entire force may not move.

Units may move directly to subsequent defensive positions without conducting a delay in between. This repositioning supports reacting to unexpected enemy successes or to other than anticipated enemy COAs. In either case, the repositioning supports the execution of a defeat mechanism based on massed fires into EAs. Repositioning also supports deception plans and shapes battlefield engagement conditions. The feasibility of subsequent positions and their number depends on the time available, engineer assets, maneuver HQ's ability to plan and designate positions in depth, and movement capacity or ability of the infantry division.

The division commander envisions a tempo and overall conduct for the battle through the depth of battlefield. He specifies large general areas as blocking positions for the brigades. Division-specified general areas do not require the brigades to physically locate all forces in the battle positions. The brigades must position adequate forces in the battle positions to accomplish the commander's stated intent for maneuver. General fortification symbols are placed on the operations overlay to establish a primary orientation for the defense and to establish engineer work priorities graphically. Division may specify strongpoints with or without a minimum unit size when deemed critical to the division operation.

The brigades still plan their battles in their sectors between lateral boundaries and between the designated division engagements. General blocking positions for brigades are not meant to be restrictive. They are provided to express the division commander's vision, tempo, and maneuver.

Blocking positions also synchronize the brigades for the division fights, and facilitate

planning of air and ground delivered fires. Fires are critical; they are planned to be the *primary* killer. Division plans EAs to focus on timed and massed artillery, aviation, and air force fires. The division commands the brigades, but does not micromanage the brigade plan or battalion operations. The division does control the brigades so that they conform with the division's maneuver, tempo, and synchronization. This may appear to be restrictive to the brigades, but it is necessary to benefit from synchronization and synergy.

The real danger lies in a division plan which fixates on one enemy COA. Intelligence must confirm or deny the enemy's possible COAs. The division plan will focus on the most probable enemy COA and then provide easy transitions to alternate COAs.

In this example, the corps defends against an enemy corps. The enemy is primarily an infantry-heavy force with motorized infantry and small tank units used for penetrations and exploitations. Its infantry divisions have one organic tank battalion. The enemy corps has one separate tank regiment and one mechanized brigade. The enemy's primary combat power is his indirect fire support. He has large numbers of MRLs, artillery, and mortar systems. Most of these systems have similar or longer ranges than comparable corps systems.

The enemy has an offensive doctrine which in general provides for a main attack to seize or destroy key objectives, a supporting attack to fix enemy forces, and an infiltration to go deep and attack reserve formations and key C² or CS assets. The infiltrations are preceded by special operations forces and followed by larger formations seeking to bypass resistance at the LD/LC.

The last enemy offensive slowed to a halt after the leading divisions suffered heavy losses. The enemy's weak logistics system is further hampered by constant USAF air attacks. The enemy is currently moving several corps forward to resume the offensive across the entire front. The enemy corps is expected to resume the offensive with its follow-on divisions in a supporting attack for the enemy army,

The enemy is expected to attack with a main and supporting attack in the south against the

reinforced 31st Infantry Division. (See Figure 4-7.) The 32d Infantry Division (+) (on the corps left) is the corps' supporting effort. It is reinforced by one separate mechanized brigade and expects to defend against one infiltrating enemy infantry division. The 32d Infantry Division may also have to defend against possible elements of the enemy's supporting attack along the corps' interdivision boundary (between the 31st and 32d divisions). The threat analysis, based on the corps intelligence estimate, was principally driven by the enemy's doctrine and the terrain. The 43d Air Assault Division is the corps reserve.

The corps-controlled security force is the corps' ACR. One cavalry squadron operates forward of the 32d Infantry Division. The rest of the ACR operates forward of the corps' main effort, the 31st Infantry Division (+). On withdrawal, the cavalry regiment reconstitutes in the corps rear area for later commitment by the corps.

The corps commander intends to destroy the enemy main attack by fires. Engagement areas will be shaped by the infantry divisions and limited objective counterattacks by the air assault division. The infantry division on the corps left is expected to defeat the enemy infiltration division and contain the enemy.

The terrain is typically rugged. Numerous valleys and high ridge lines run generally parallel to our lines of operation with frequent mountain masses and rivers or streams interrupting the ridge lines. The valleys vary in width and are primarily used for agriculture. Numerous small villages are located in the valleys. Evergreen and deciduous trees cover the hills and ridges. Slopes are generally steep. With bank preparation, rivers are fordable by most tactical vehicles. The most rugged terrain in the corps area is in the 32d Infantry Division sector (corps left). This sector has generally rough terrain and few roads or trails. The valleys are narrow and run into several dominant high-hill masses. Vehicle trafficability in the valleys depends on soil moisture content. During the spring and summer, irrigation, crop flooding, and rains generally limit vehicles to roads and high ground. The terrain in the 31st Infantry Division (corps right) gradually becomes less *severe* farther away from the 32d Infantry Division sector.

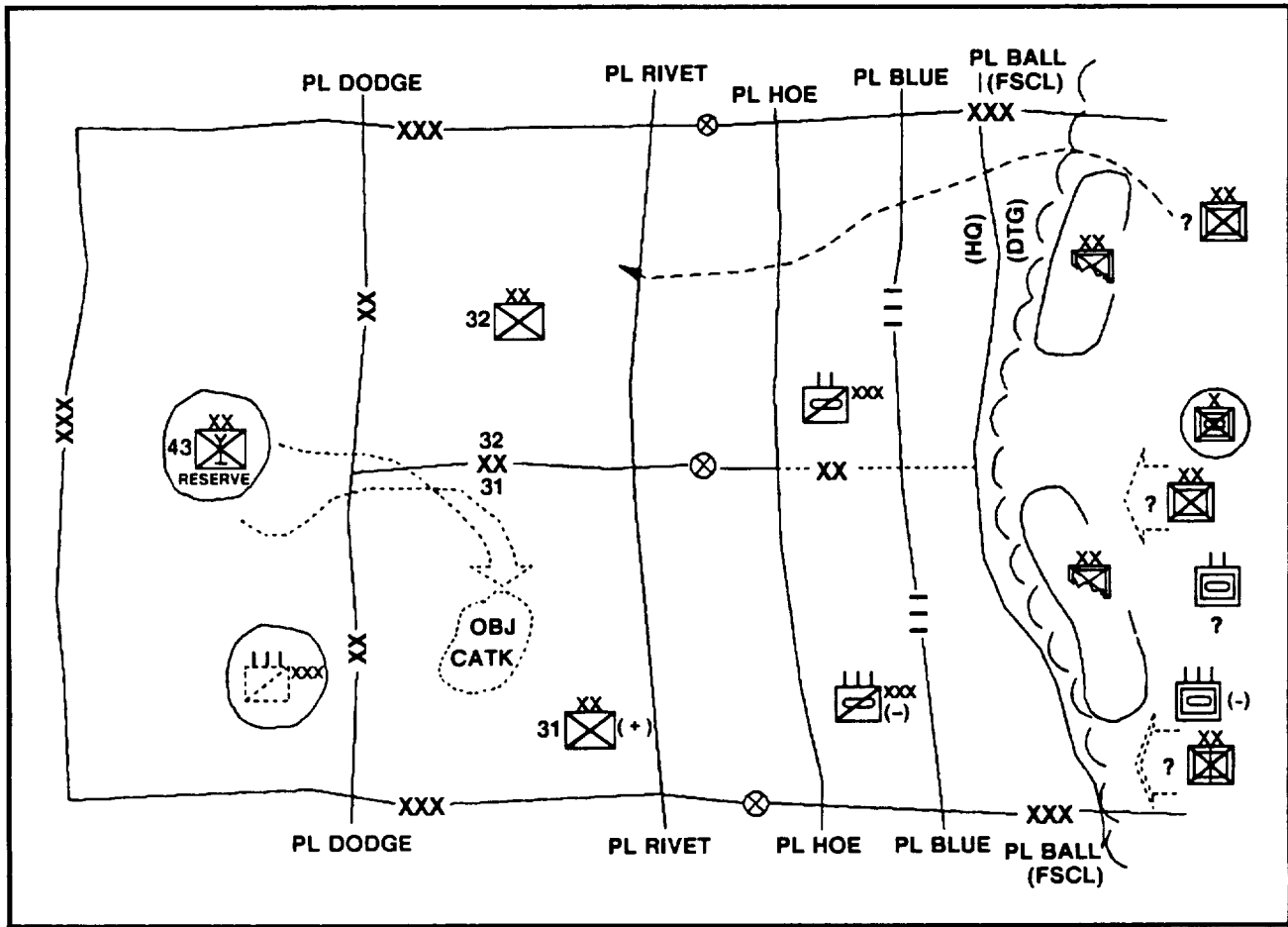

Figure 4-7. Corps situation

This sector on the corps right generally has wider valleys, providing better off-road vehicle trafficability, and more roads to support motorized and armored unit attacks. This is the best sector for the enemy to employ armored units. There are several cross corridors over the interdivision boundary between PL RIVET and PL DODGE.

The corps defeats the first enemy attack forward of PL HOE and establishes a hasty defense. The depleted leading enemy divisions establish defensive positions in the vicinity of PL BALL. The corps commander orders the forward divisions to establish a defense on stronger terrain to the rear of PL BLUE. As they pull back, the corps ACR establishes a security zone forward of PL BLUE. The divisions construct barriers and defensive positions in depth from their new FEBA,

integrating into those left over from previous operations.

Maneuver

The corps commander intends to defeat the enemy corps' attack forward of PL DODGE with a defense in depth. The army commander exploits success with a counteroffense with a reserve corps. The corps commander's intent is to defeat the enemy forward of brigade rear boundaries--not to retain terrain. Terrain is only a combat multiplier in this defense.

This example now discusses the tactics and techniques for employing the 32d Infantry Division (on the corps left), which will be referred to as the division or infantry division.

The terrain in the division's sector is very rough but gradually decreases in its severity from

north to south (left to right). It does not favor using tracked vehicles, except on the right (south) where a few small armored avenues are present. These avenues are primarily trails in narrow valleys. The corps commander has resourced the division with sufficient artillery, engineer, air, and aviation assets to fight an infantry attrition battle in rough terrain. This division is unlikely to get additional corps units or support unless the enemy shifts his main effort.

The division commander's mission analysis confirms the corps' estimate of the situation. His priority mission is to first defeat the expected infiltrating division and block enemy forces attacking in sector along his right boundary. He must prevent them from penetrating and enveloping the adjacent division on the right—the corps'

main effort. (See Figure 4-8.) The terrain favors this mission.

The division commander deploys three brigades abreast. This decision was influenced by the strength of the terrain, width of sector given to the supporting effort division, and numerous enemy infantry avenues of approach. These brigades influence and canalize enemy infantry units into EAs where they are destroyed with massed mortars, artillery, CAS, and attack helicopter fires. Infantry maneuver is limited to moving between blocking positions and a few limited counterattacks (counterpenetration). These movements are dictated by unexpected enemy movements (through deep NAIs and DPs) to contain penetrations or to counter his attempts to envelop critical positions or units. After defeating

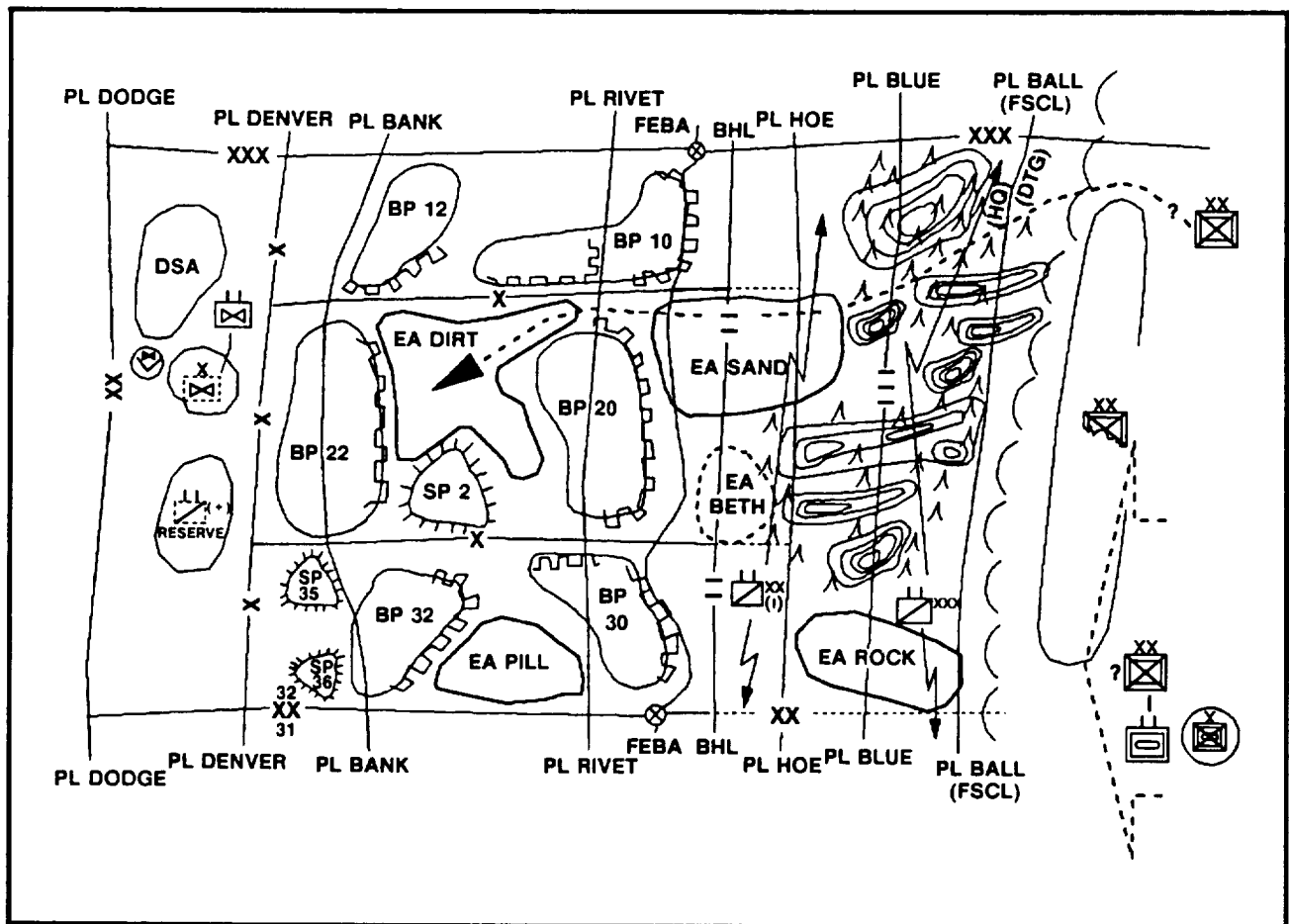

Figure 4-8. Maneuver: division concept of operations

the enemy infantry in sector, the division plans a sequel to clear zone to PL BALL in support of the army counteroffensive.

The corps has additional GS assets but they are positioned to support the main effort, corps deep operations, and reserve. Since the division is the supporting effort, it will not receive additional

support until the enemy shifts his main effort into the division sector. The division's task organization is shown at Figure 4-9.

Deep Operations

The MI battalion's LRSD platoon and the attached infantry platoon are deployed for intelligence collection and targeting purposes. The

<i>1st Bde</i>	<i>2d Bde</i>	<i>3d Bde</i>
Inf Bn	Inf Bn	Inf Bn
Inf Bn	Inf Bn	Inf Bn (-)
Inf Bn (-) (OPCON)	Inf Bn	FA Bn (105T) (DS)
Avn Bde (o/o	FA Bn (105T) (DS)	Btry (V/S)ADA Bn (DS)
Atchd 1st Bde)	Plt/Btry(V/S)ADA Bn (DS)	Plt/Btry (V/S)ADA Bn (DS)
FA Bn (105T) (DS)	Engr Bn (W)/xxx	Engr Bn (W)/xxx
Btry (V/S)ADA Bn (-) (DS)	Co/Engr Bn (Lt)	GSR Sqd
Engr Bn (W)/xxx (-)	Chem Plt (Smk/Decon) (DS)	FSB
Chem Plt (Smk/Decon) (DS)	FSB	CA Tm
GSR Sqd	CA Tm	PSYOP Tm
FSB	PSYOP Tm	
CA Tm		
PSYOP Tm		
DIVARTY	Avn Bde	Division Troops
FA Bn (155SP) (GS)	Div Cav Sqdn (o/o,	Inf Bn (Div Reserve)
(o/o Atchd FA Bde)	Div Reserve)	o/o Atchd to 2d Bde)
FA Bn (MLRS) (GS)	Inf Bn (-) (OPCON, o/o)	Cav Sqd Lt xxx (OPCON)
TAD Det/xxx	Inf Co	MI Bn (-)
	Inf Co	Inf Plt 2d Bde
DISCOM	FA Bde (DS Avn Bde	ADA Bn (-) (GS)
MSB	o/o R DIVARTY)	Plt/Btry (V/S) GS
Trk Co:xxx	FA Bn (155T):xxx (o/o R,	Radar Maint Plt (Stngr)
Trk Co:xxx	1 Bde DS Arty Bn)	Radar Maint Plt (Stngr)
CA Co (-)	FA Bn (155T):xxx (o/o R	MP Co (xx) (GS)
	2 Bde DS Arty Bn)	INF Plt/3d Bde
	FA Btry (155T):xx (o/o R	Band xx
	3 Bde DS Arty Bn)	CS Co (-) xxx
	FA Bn (155T):xxx	GSR Plt (-)/MI Bn (o/o Atchd
	Co/Engr Bn (Lt)	from Avn Bde)
	Engr Co/Engr Bn (W):xxx	Engr Gp (OPCON)
	Atk Hel Bn/xx	Engr Bn (Whl):xx(-) (GS)
	Atk Hel Bn:xxx (OPCON)	CSE Co
	Aslt Hel Co:xx	CSE Co (-) (GS)
	Aslt Hel Co:xx	CSE Co (-) (GS)
	Aslt Hel Co:xxx	Engr Bridge Co (MGB) (GS)
	Btry (V/S) (-) (OPCON,	Signal Bn (GS)
	o/o DS to 2d Bde)	PSYOP Co (-) (GS)
	Plt Btry (V/S)	Chem Co (Smk/Decon):xxx (GS)
	GSR Sqd/GSR Plt (o/o	
	Atchd to MP Co)	

Figure 4-9. Task organization

LRSD teams are positioned in the vicinity of PL BALL and beyond. They are positioned at NAIs selected to observe movements and support targeting. Their observations corroborate other surveillance systems for the early confirmation or denial of enemy COAs. Their primary effort is targeting. The 2d brigade infantry platoon (or scout platoon) is attached to the MI battalion to augment the LRSD effort. The division G3 provides capability to this platoon to communicate with the LRSD base section.

Forward of PL BALL, long-range surveillance (LRS) teams are inserted by helicopters accompanying attack helicopter missions. Infiltration is the alternate insertion method, given adequate time. Behind PL BALL, the teams deploy with the aviation brigade's covering forces and then infiltrate to their positions. Target locations (without observer adjustments) are called in via tasked communications to the LRSD base station and then forwarded to the collection, management, and dissemination (CMD) section and FAIO. The division G2 and DIVARTY S2 coordinate deceptive fires and deep operations fires (targeted by other than LRS teams) to hamper the enemy's deduction or perception of deep LRS team-observed fires.

Deception is targeted at the enemy corps and division commanders. The division's defense should appear to be a forward linear defense in sector on a forward of PL HOE. The deception uses the previously established positions on PL HOE and the former reserve positions in the PL RIVET area. The division commander wants the enemy to expand its artillery preparations on the wrong positions and thereby allow counterfire operations to begin early.

One corps cavalry squadron screens forward in front of the division out to PL BALL. The division light cavalry squadron screen is on PL HOE. The corps squadron's priority is in the south where vehicle movement is easiest for both sides. The light cavalry squadron conducts counter-reconnaissance and attrits enemy infantry units by aerial or indirect fires. A covering force was not used because the security zone is too shallow; the terrain limits movements and observation; and insufficient forces are available to counter the superior infantry threat in a covering force area.

Obstacles and terrain benefit the brigade fights. Enemy movement and tempo may be easily influenced with sufficient artillery, CAS, and FASCAM. Obstacles emplaced behind the screening force further reinforce the rough terrain and increase the effectiveness of deep fires as the screen withdraws. These fires not only initially achieve attritions but also influence enemy movements.

Combined obstacles and fires produce the necessary attritions and disruption and alter the tempos for enemy regiments and battalions. The enemy's main attack, reserves, and artillery will seek the best avenues. Our fires and obstacles influence them to stay on or change those avenues and then eventually run into our EAs. Fires and obstacles are also planned on the ridge lines above the valleys. They are used to delay and attrit infantry units attempting to infiltrate, by-pass, or envelop our defensive positions.

Deep operations fires are initially targeted on enemy division fire support assets, C² nodes, AD systems, moving infantry formations, and tank units. Moving infantry formations are attacked with massed and timed fires. These infantry formations are moving in the division's deep operations area. The priority for attack is units moving toward our economy of force area, then those moving away from our engagement areas, and finally deeper echelons. The LRSD teams and other real-time intelligence sources provide eyes-on targeting data so that deep fires provide attrition as well as influence movement. Proactive and reactive counterfire operations by the division are critical deep operations. Artillery is the enemy's major combat power asset and the greatest threat to our infantry's freedom of action. Therefore, the G3 manages deep fires to support the maneuver concept. We attack enemy C² nodes when the close fight is begun to degrade his ability to see our COA and counter it. The enemy's C² resolution to initial tactical defeat in our division sector must come from the enemy corps HQ and above.

Initially, counter the priority is on long-range weapon systems the enemy uses to conduct his counterfire missions. The second priority is to achieve a sustained daily attrition rate on all enemy artillery. The specified rate should achieve

a total loss to his artillery. This is necessary for our freedom of action and maneuver in the counteroffensive sequel. Counterfire may be directed at enemy units or targets of opportunity across the front, or concentrated in one area, forcing him to cross level assets. This overall effect decreases his correlation of forces. During the enemy's approach march, we focus counterfire on artillery formations supporting ground attacks into our economy of force sectors, and on the enemy counterfire systems. During our security force fight, priority for reactive and proactive counterfire missions shifts to enemy artillery units supporting the enemy's main attack.

Counterfire is a must. The infantry cannot move from prepared positions to subsequent alternate or supplementary positions while under artillery fire. Freedom of action is possible only when our counterfire negates the enemy's artillery and mortar fire support.

SEAD must begin early as *complementary* SEAD. Complementary SEAD must decrease the density of AD systems so that our aviation assets are more effective in the close fight. This is critical since the infantry division relies heavily on attack helicopters and air support for deep operations, proactive counterfire, and subsequent close support.

When the enemy main attack enters division EAs, some deep operations are temporarily suspended; however, targeting, intelligence, psychological warfare, and deception are continuous. Most fires are used for massed fire missions into EAs, with emphasis on time on target and JAAT missions. The G3 will order resumption of deep fires (from the main CP) based on targeting and intelligence for the deep operation. The number of deep missions or percent of fires assets shifted is based on the status of the current close operation (from TAC CP), the wargamed synchronization matrix (decision points), and ammunition availability.

The G3 in the main CP synchronizes the deep operation to the close operation and coordinates the transition from future plans (sequels) and contingency plans (branches) to the current operation. The G3 acts within the division commander's intent and the wargamed "decide" phase guidance. The division commander inter-

rupts the G3's fight only when the intent on decide guidance must be changed.

Division deep operations continuously target enemy forces not committed to the close fight. Fires are targeted separately on enemy battalions. These fires disrupt the enemy's tempo, movement, synchronization, fire support, and control.

The G3 coordinates a battle damage assessment collection plan with the G2. Neither the effects nor the success of deep operations can be determined without battle damage assessment. Surveillance (ground and electronic) and aerial reconnaissance are the collection means that must be planned. Battle damage assessment results and deep operations assessments are the first CCIR for branch (reattack, task organization, reposition forces, and counterattack) and sequel (delay, attack, or withdraw) decisions.

The G3 and G2 coordinate the handoff (from corps) of the enemy corps' second echelon, trailing, or reserve divisions as they enter the division deep operations area. The division G3 assesses the status of the division's close operation. The division may have requested the corps to attack those divisions prior to their arrival in the division deep operations area. The corps responds, first, within its intent, vision, and concept of its own operation and, second, by its capabilities and priorities.

In this example, the infantry division is not initially the corps' main effort. Corps support will probably be limited to supporting the corps' overall intent. It will be less responsive to supporting the division's deep fires needs—unless the interests, intents, and time lines are nested.

The G3 must assess the impact of a failed or less than successful deep operation and the introduction of new or unexpected enemy forces into the division sector. He considers the near-term impact on the close operation, future impact on subsequent operations, his deep operations assets' availability and capacity, and the associated time-distance factors.

The G3 may order reattack missions to compensate for previous unsuccessful or less than successful missions. He counters unexpected new enemy units by initiating deep operations targeted on the lead elements of those units to

buy time. He then provides his assessment and recommendation to the division commander--continue with the current operation, execute a branch within X hours, or adopt a sequel OPLAN within Y hours.

Security Operations

The security force is division-controlled and executed by the aviation brigade. The available forces include the division cavalry squadron with two attached light infantry companies; one division attack battalion and one OPCON corps attack helicopter battalion; one OPCON corps and two divisional combat aviation companies; and engineer, ADA, GSR, and chemical smoke units. The security force unit's mission is to provide early warning, destroy enemy reconnaissance elements, influence enemy movements into EA SAND and EA ROCK, and attrit the leading enemy units using fires only.

By the time of contact, the enemy's COA should be confirmed. Time for necessary repositioning is gained through the combination of deep operations and disruption or delay caused by attritions inflicted by the security force.

One corps cavalry squadron initially conducts a screen forward of the division under corps control. The majority of this squadron are employed in the southern half of the division sector focused on the corps' interests. This squadron will withdraw quickly because of the shallow depth of the security force area. This corps security force area is between PL BLUE and PL BALL.

The brigades are tasked to maintain contact between themselves and the adjacent divisions. Contact is defined to be at least continuous reconnaissance or surveillance between adjacent units. Without mutually supporting fires or designated security forces, adjacent commanders must coordinate tactical responses to contain or defeat enemy penetrations. The responsibility is left to right and rear to front (for defense in depth) unless modified by mutual agreement between commanders.

The enemy can easily bypass friendly units, which are deployed in depth rather than linearly. Bypassed units can be accepted in the defense in depth; however, the commander accepts them with full knowledge, not by surprise. In a defense

in depth, the flank to be secured is difficult for the division commander to perceive, except in terms of maneuver and tempo. The senior commander designates a phase line to be used as a reconnaissance and surveillance line which must be maintained by security operations. The intent is to maintain freedom of movement and minimize surprise envelopments, infiltrations, or penetrations beyond or behind the designated phase line.

The division commander is reasonably certain that any enemy forces crossing the phase line have been seen and reported and or tracked. He can assess the impact or threat to his freedom of action or maneuver with a degree of confidence. Forward of the phase line, the reliability of his assessment decreases. Units forward of the designated phase line are responsible for their own security. They are left forward by design based on the overall operation. The senior commander's concept of operation or timeline concept by design should not be affected if those forward units are bypassed. The phase line is moved rearward as the enemy moves forward in sector until it is on the last delay position or defensive line. Here, its purpose is to prevent surprise enemy penetrations into the division rear area. If necessary, the division commander may establish a security or R&S area behind the brigades with the division cavalry squadron and division reserve blocking positions. The mission could be expanded to a screen mission by requiring the screen force to destroy enemy infiltrators or reconnaissance elements. If properly reinforced, the mission becomes a covering force that contains or destroys small penetrations.

Close Operations

This division commander specifies *general* blocking positions for the brigades. By doctrine, this is unusual. However, the division commander wants to alter the tempo of the enemy forces, establish the tempo and maneuver of the friendly brigades, establish EAs for massed division fires, and focus the division's effort to support his vision. General battle positions, fortifications or prepared positions, obstacle areas, and engagement zone graphics express his intent and vision for maneuver, synchronization, and conduct of the battle.

Graphics depict general blocking positions and fortification symbols to focus brigade effort. Coordinating instructions in the division OPORD direct the brigades to analyze the METT-T and determine tactically feasible and correct battle positions. General fortification symbols on the overlay focus primary orientation and degree of resistance and also engineer effort. At the division level, the exact trace or length of the fortification symbol does not represent detailed requirements or tasks. It only conveys intent. The blocking position symbols do not specify the size of the force to occupy the position. Again, they only convey intent. The brigades are not required to position the bulk of forces inside the specified blocking position symbol. Brigades must position forces, reinforce the terrain, and construct prepared and fortified positions so that the division commander's intent and vision are satisfied with respect to the enemy. This synchronizes combat effort of brigades to the division maneuver concept, alters tempo, and shapes conditions for the close battle. Synchronization is confirmed during the division commander's backbrief rehearsal with his subordinate commanders. The commander specifies blocking positions only when he believes they are required for expressing a clear intent and concept.

The 2d brigade sector is the key to the concept of operations. The enemy's main attack with infantry units is expected in the 1st and 2d brigade sectors. An enemy supporting effort with some tanks is expected in the 3d brigade area, possibly with forces crossing over the boundary from the adjacent friendly division's sector. The 3d brigade must contain armored penetrations forward of PL BANK and ensure that 2d brigade is not enveloped from the 3d brigade sector.

However, enemy infantry may also use avenues of approach through the rough terrain in division's center into battle positions 20 and 30. Engagement area BETH was specified to counter this possibility. The 1st brigade turns enemy units into the 2d brigade sector (EA SAND). The 2d brigade inflicts heavy attritions on the enemy in EA SAND, turns surviving enemy units into EA DIRT, and avoids being encircled on BP20. The combination of the battalion-sized strongpoint 2 and BP22 denies the enemy's access to the division rear, Strongpoint 2 also stops the enemy

from massing and crossing over between EA PILL and EA DIRT. The 2d and 3d brigade defenses protect the division rear as well and contain the enemy's supporting attack against the corps. The 1st brigade secures the division flank and denies any penetration of PL BANK. If the enemy's main effort is in the south, the division will retain BP10 (1st brigade), BP20 and SP2 (2d brigade) and BP32, BP30, SP36, and SP35 (3d brigade). The 3d brigade will provide a battalion as the division reserve.

If the enemy is not successful in the 3d brigade sector, the 2d brigade may leave forces in BP20. Then the 1st and 2d brigades will conduct a true defense in depth. Otherwise, the 2d brigade operation will be a delay to BP22 and SP2.

Because of the 2d brigade's pivotal role, the division commander must approve any battalion-sized decisive engagements in their sector forward of PL BANK. Approval is initially coordinated in the planning backbrief process on a concept or a request basis during the operation.

According to the division plan, the 1st brigade accepts decisive engagement in sector which turns the enemy formations into EA SAND and or EA DIRT. The 1st brigade maintains contact with adjacent division on the left. The 3d brigade must accept decisive engagement until the 2d brigade withdraws from BP20. The division commander decides to defend or withdraw from BP20 based on intelligence collections on the enemy's movements in the vicinity of PL BALL. After the BP20 action, the 3d brigade commander decides when to accept decisive engagement.

The division commander intends to minimize subordinate unit movements. When necessary, they are accomplished primarily by vehicle or helicopter. This conserves soldier strength and builds unit tempo. Specific situations may need combinations of truck, air, and foot movements. Repositioning movements are feasible when envisioned and planned. Detailed planning is required for the sequence of moves, assembly areas, routes, lift assets, number of lifts, disengagement fires, and covering fires.

The defense in depth to defeat enemy forces focuses on enemy unit movements through the defensive sector. The division commander states his

vision to influence the enemy movements through the use of infantry operations and deep operations. The division must provide a concept of operations, designated general battle positions, EAs, and obstacle area intents, and then detail what the brigades must do to support the division.

Brigade commanders must still plan their operations to support the commander's intent. The division has not specified the size of forces to occupy division-designated battle positions (BPs) nor have they articulated the BP occupants' sequence. The brigades must also determine when and where they will accept decisive engagement. They must determine how they will contain the enemy forces in the designated EAs and prevent enemy penetration or infiltration through their sectors.

The maneuver concept of the operation allows defensive positions to prepare in depth to counter COAs. This is not possible if the brigades plan their own operations without a division-level maneuver concept or vision. This concept can accommodate a true defense in depth with small units firing from numerous positions onto the avenue or into the EA. These units would be in a high-risk situation against a strong enemy infantry force, which would attack and destroy these dispersed positions. Therefore, the division must maintain some control through a maneuver concept. Targets are developed with the brigades to be attacked by massed division fires. The division controls movements between BPs until the division can accept a decisive engagement. At this point, the brigade commander, by his plan, may have forces deployed in depth over a shallower depth of the sector than in a true defense in depth. The infantry unit does require the maneuver and speed potential afforded by helicopter and trucks plus massed fires in order to break contact and move. The division commander must envision this battle and orchestrate its execution. He must therefore impose his will on his brigades before he can impose his will on the enemy.

Reserve Operations

During the security force operation, the division reserve is a designated infantry battalion. This battalion is preparing a position in BP22 (in the 2d brigade area). Aviation lift assets and DISCOM trucks have been identified and given

on-order missions to move the division reserve (-) beginning not later than one hour after notification. The first airlift company should begin movement NLT 30 minutes after notification.

Following the security force operation, the reinforced division cavalry squadron becomes the division reserve *after* a brief reorganization period. The reserve's mission is to counter enemy penetrations and infiltrations with limited objective counterattacks. The enemy must be contained within the EAs. The priority of employment by sector is 2d brigade, 3d brigade, and 1st brigade, in order.

The reserve will be reconstituted with an attack helicopter battalion and a reorganized engineer company taken from engineers supporting the 1st brigade. The division reserve provides Level III response to threats since a dedicated TCF is not feasible in this example. The rear CP exercises control and planning authority.

Rear Operations

The enemy poses a significant threat to the rear area with special operations elements and infiltrating units. The division rear is organized into mutually supporting base clusters under the control of the rear CP. Rear area units are localized as much as possible in the DSA for security reasons.

The division does not have sufficient forces to have a dedicated TCF. During the battle, the reinforced division MP company responds to Level II rear area missions.

During the security force operation, the designated division reserve, (one infantry battalion), provides to Level III response to threats. After the security force operation, the division cavalry squadron (+) provides Level III response to threats. The division OPORD specifies "be prepared" missions for artillery and attack helicopter support within a specified time period. The response time is a derivative of the movement plan and transportation assets that are provided (organic, attached, or DS) or are available (on order or be prepared GS).

Intelligence

The G3 develops a decision support template based on the chosen COA for close and deep operations. The defending infantry units must be

correctly positioned in prepared positions to defeat the larger enemy force. If repositioning is required, it must occur before contact is made on PL RIVET. Decision points on the DST trigger repositioning moves.

Intelligence operations must provide maximum lead time to maneuver commanders by early confirmation or denial of the enemy COA. Priority for intelligence operations then shifts to the critical targeting effort. Our principal defeat mechanism is massed fires on exposed formations. Targeting, therefore, flows from the initial tactical intelligence priority collections.

The division collection plan is synchronized to the corps plan to deconflict competing demands of intelligence and targeting operations. The corps supports the intelligence collection effort. These collections typically involve longer-range assets for which the corps usually has a common collection interest. Targeting for the division is typically detailed, asset-intensive, and focused in the division's deep operations areas. Corps targeting effort is beyond the division's deep operations area. Therefore, corps and division targeting efforts do not generally overlap. The division coordinates a phase line with the corps for handoff so that an intelligence gap is not created. The coordinated handoff of moving and targeted units from corps to division is critical to success.

One infantry platoon has been attached to the MI battalion to increase the LRSD targeting capacity. The platoon reorganizes into five teams: platoon HQ and net control, three squads (-) under the squad leaders, and a provisional team under the platoon sergeant. The platoon leader, with FM and tactical satellite (TACSAT) radio capability, acts as the platoon net control and communicates with the MI battalion's LRSD base station. The platoon sergeant, with a provisional team, acts as an alternate NCS. The three organic squads (-) report via radio to the NCS when deployed.

Both the LRSD and attached infantry platoon teams are positioned to observe NAIs, TAIs, and DPs. They are inserted by helicopter beyond the covering force and then deploy on foot. Those teams located short of, or in, the covering force unit area are inserted by vehicle and then deploy

on foot. The primary purpose for all teams is to support the targeting process.

The division MI battalion's collection assets are task-organized as company teams. These three teams are retained in GS under the control of company A HQ. One team is located in each brigade area and an intelligence liaison officer is provided to each maneuver brigade HQ. The brigade commander can task the team or MI battalion with information requests directly through the liaison officer. Company A HQ locates in the 2d brigade area. The company commander coordinates locations for collectors directly with the brigades or with the security force brigade HQ.

The I&S company (-) locates with the division EPW collection compound. It is GS to the division. Each of its ground surveillance radar (GSR) squads is attached to a maneuver brigade. The platoon HQ with one remaining GSR squad is DS to the division security force. On order, it is attached to the division MP company. In the forward area, the GSRs are used for early warning. In the rear, the GSRs are used for rear area security and surveillance operations.

Initially, PIR are to confirm or deny the enemy COA. Specifically, the commander wants to know--

- Time of the enemy attack and the avenues of approach.
- Location of the enemy main attack (now expected on the right flank).
- Location of organic enemy tank battalions.
- Location of the mechanized brigade.
- Location of the expected infantry division infiltration into the division area.
- Location of corps and division supporting artillery units.

Targeting priorities are on division-level enemy artillery units. Priority is to MRLs and corps and division-level artillery groupings, C² nodes, AD systems, moving infantry battalions on avenue A, moving infantry battalions on avenue C, and then tank units in the 3d brigade sector. On order, targeting priority shifts to infantry battalions on avenues of approach B1 and B2.

Fire Support

The corps has task-organized one FA brigade to reinforce the infantry division. The corps delegates authority to the division commander to subassign missions. The FA brigade has three towed 155-millimeter FA battalions, one 155-millimeter SP FA battalion, and one MLRS FA battalion.

Initially, the aviation brigade executes the division's security force fight out to PL HOE. The corps FA brigade is initially DS to the aviation brigade for the security mission, with on order mission to reinforce DIVARTY. Three corps towed 155-millimeter FA battalions and the DIVARTY towed 155-millimeter battery are attached to the FA brigade for the mission. All four units are located forward in the brigade sectors to

facilitate their subsequent reinforcing missions. (See Figure 4-10.)

DIVARTY HQ initially controls the corps MLRS battalion, the 155 SP FA battalion, and the target acquisition detachment. DIVARTY controls deep operations and counterfire operations. On order, massed fire and time-on-target missions on massed enemy infantry units are the frost priority. The DS FA battalions are left with the maneuver brigades to fire on enemy infiltrations or penetrations.

The divisional cavalry squadron does not have organic fire support teams (FISTS) for the security force fight. However, the two attached infantry companies both have FISTS. The divisional cavalry squadron employs DIVARTY

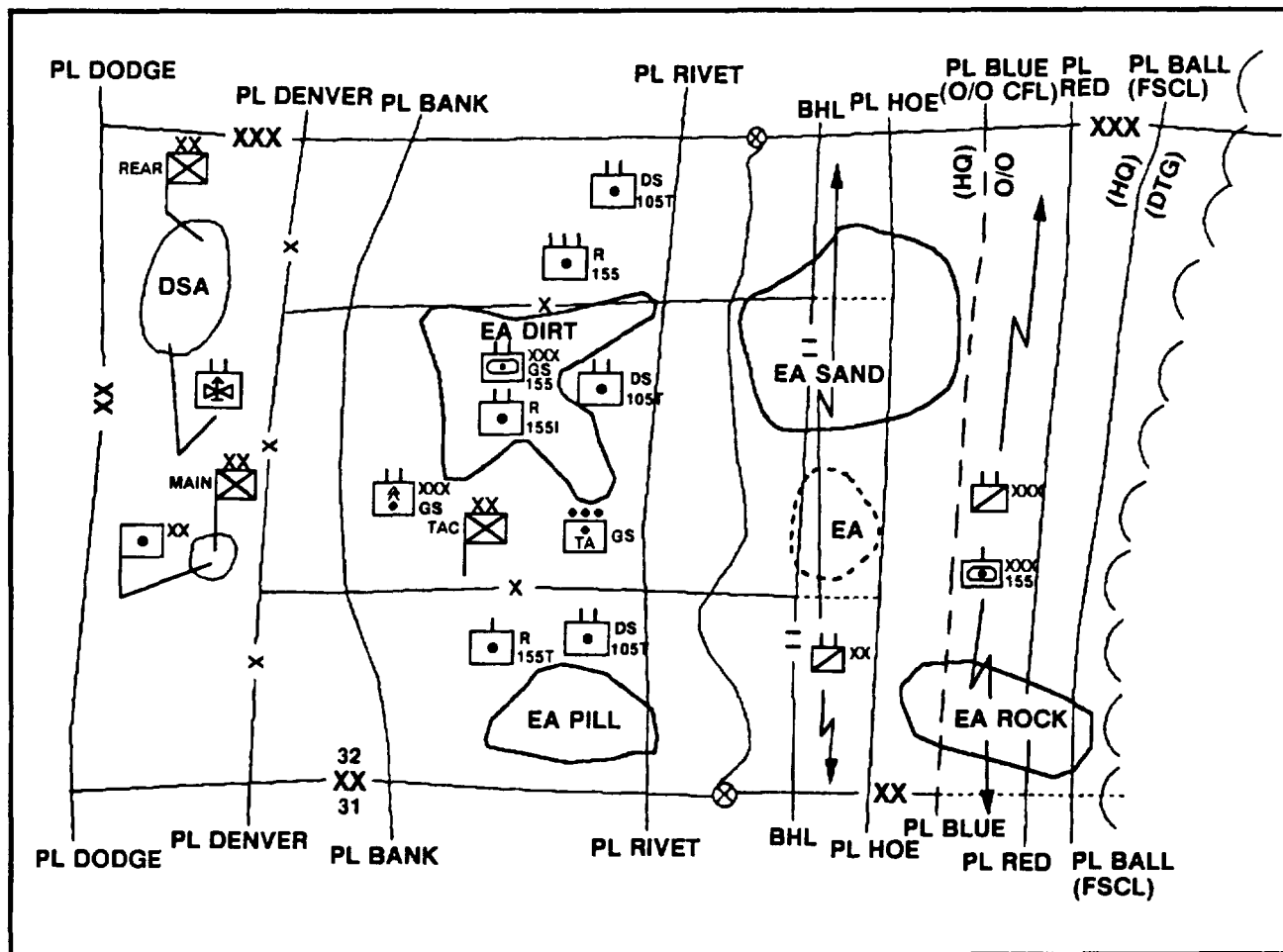

Figure 4-10. Area defense in sector: fire support

combat operation laser teams (COLTS) during the security force operation.

COLTS are important since each enemy infantry division has one organic tank battalion. The FA brigade specifies support relationships and Quickfire channels for all battalion HQ, troops, and companies.

The corps withdraws the ACR, leaving the division-controlled aviation brigade security force between the BHL and PL BLUE. The divisional cavalry squadron remains forward until withdrawn. The FA brigade supports it from the MBA.

After the cavalry squadron withdraws, the division fights in depth with three brigades abreast. All three are supported by their habitual towed 105-millimeter FA battalions. The 1st and 2d brigade DS battalions are each reinforced by one 155-millimeter towed FA battalion. The 3d brigade DS artillery battalion is reinforced by the divisional towed 155-millimeter FA battery. The DIVARTY is GS to the division with first priority to counterfire and massed fires on order. The DIVARTY controls the MLRS battalion and the target acquisition platoon. The FA brigade provides GS tires with one 155 SP battalion and one towed 155-millimeter battalion. These battalions support the division's deep operations, counterfire, and SE AD, as well as the maneuver brigades.

Initially, PL BALL is the FSCL. When the corps security force withdraws, a CFL is established on PL RED. From that point on, CFLs and FSCLs are moved using successive phase lines. To the rear of PL RIVET, infantry units are or may be deployed in depth. Brigade commanders establish CFLs for their sectors to the rear of PL RIVET, which are consolidated at the TAC and approved by the commander.

The division commander's defeat mechanism is to use massed fires to destroy enemy units in EAs. Infantry units in prepared positions, close fires, and deep operations must canalize the enemy into those EAs. The DIVARTY coordinates the positioning of all fire assets so that massed fires and time-on-target missions are possible across the division front, with priority to the EAs. Those EAs designated support the division concept. Maneuver brigade commanders may coordi-

nate their own EAs through their FSOs to support their maneuver concept.

Mobility and Survivability

The infantry division does not have a division engineer brigade and must rely on the corps for adequate engineer support. The corps engineer brigade has four engineer groups which support the corps rear and the three infantry divisions. The infantry division's engineer group is task-organized with three combat engineer battalions (wheeled), three CS equipment companies, and one engineer bridge company. The division has the authority to subassign missions.

During the wargaming process, the division commander, G3, G2, and division engineer developed a maneuver with a supporting mobility, countermobility, survivability concept. The division commander has specified obstacle areas with his obstacle intent for each area. These areas are a graphic expression of the commander's vision to influence enemy maneuver and tempo. Engineer effort, coordination, and CSS requirements are guided by this vision. It is a commander's maneuver vision, not an engineer's obstacle plan. The subordinate commanders at brigades do the same. They are free to plan tactical obstacles and belts inside the division's obstacle zone. Protective obstacles can be planned outside of obstacle control measures. However, the brigades must accomplish the division commander's overall maneuver, tempo, and countermobility intent as their first priority. The total effect of all obstacles in the division obstacle areas must accomplish the division's intended purpose. The brigade and battalion commanders' roles are to translate division maneuver-based obstacle areas into tactically correct and feasible obstacles. (See Figure 4-11.) Obstacle areas and restricted areas were further discussed in this chapter's Defense in Sector: Terrain Retention. Obstacles are planned IAW FM 90-7.

The division commander wishes to canalize the expected enemy infantry division attack into EA SAND and then EA DIRT on avenue of approach A. Enemy infantry on avenue B is to be contained at EA BETH and then canalized into EA DIRT. Enemy flank units from the enemy corps main attack in the adjacent division sector

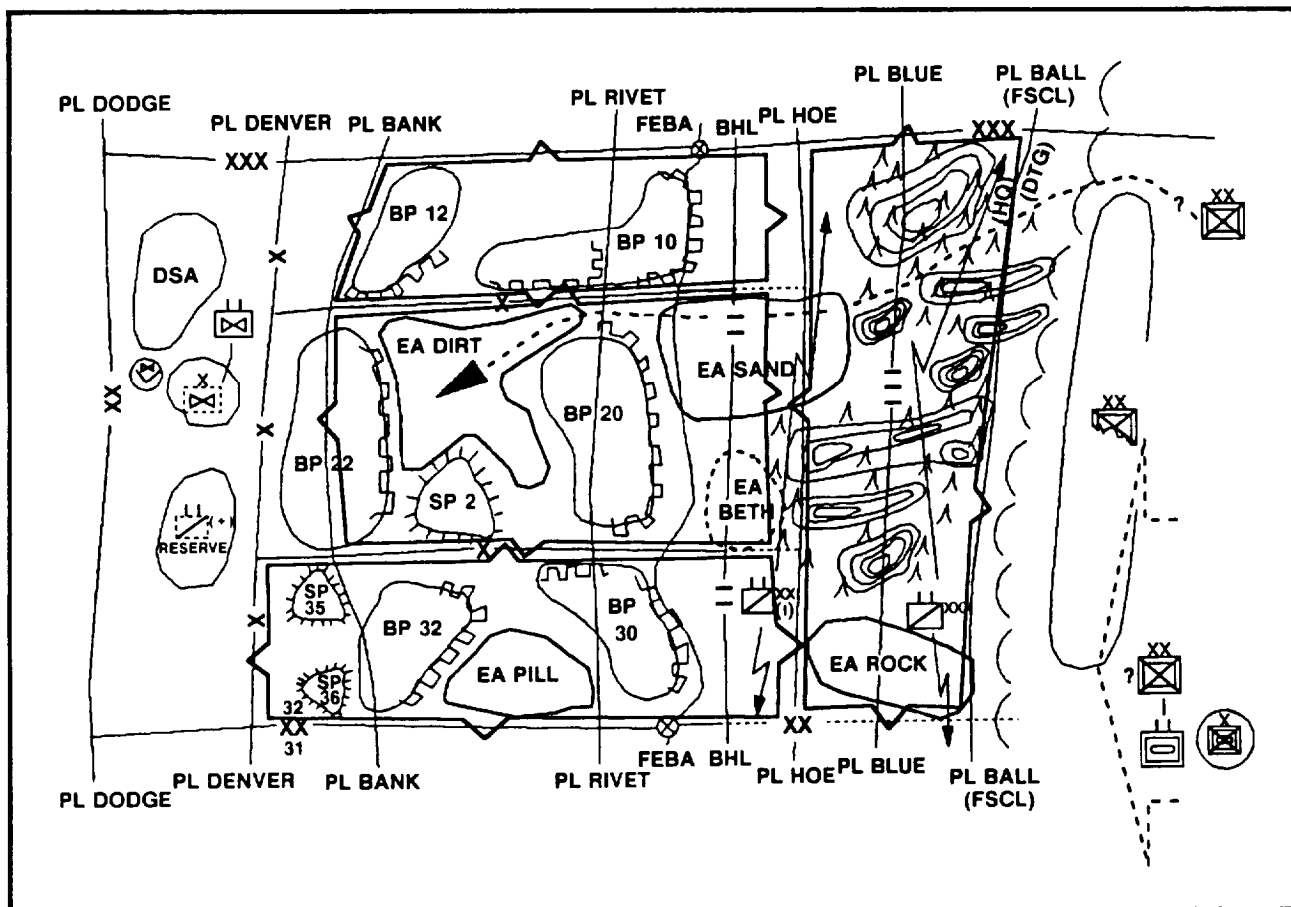

Figure 4-11. Area defense in sector: mobility and survivability

may enter the 3d brigade sector on avenue C. These units must be contained in EA ROCK, if possible. If not, they must be canalized into EA PILL and destroyed. (See Figure 4-10.)

The division inherited obstacles from previous combat operations between PL MOE and PL BALL. This area is now the current division and corps security areas. Corps and division engineers coordinate the work in the security areas behind the security forces to support the maneuver plan. Corps and division engineers task and allocate the engineer work.

Obstacle areas A, E, B, C, D, and G were assumed by the division from other divisions which had previously fought on the terrain. Engineers supporting the security force reinforced obstacles in areas A, B, C, and D. Obstacle area E was modified to a turning obstacle zone. Obstacle area

G was modified and reinforced to a disruption obstacle zone.

The security force also inherited some minefield, tank ditches, obstacles, and bridge demolitions. These obstacles are controlled individually since they do not conform to any area, zone, belt, or group. If they interfere with operations or present a threat to friendly units, they are cleared or reduced. They are marked and left in place if they are not a significant hazard or if insufficient engineer assets are available. They are treated as targets or nuisance obstacles.

The division specifies lanes and gaps through obstacle areas to support activities. In this case, division specifies lanes and gaps to support the covering force's withdrawal, with the covering force HQ coordinating the details. Brigades controlling the obstacle areas with the designated

lanes or gaps must prepare, mark, and then close them. The division commander reserves execution authority to close them until the covering force withdraws. However, all brigades may close lanes or gaps to prevent enemy capture.

The division engineer work line (EWL) is PL BANK. The corps EWL is PL DODGE except that corps will repair and maintain all corps MSRs forward of PL DODGE to the committed divisions' DSAs.

Engineer priority of effort is to counter-mobility, survivability, and mobility, and then to sustainment engineering. Priority of support is 1st, 2d, and 3d brigades; covering force; DISCOM; and DIVARTY.

Following the covering force fight, the corps wheeled engineer company is attached to the corps GS wheeled battalion in the division rear. This battalion provides engineer C² for all engineer work behind the EWL. It controls one wheeled company (after the covering force fight), two combat support equipment (CSE) companies (-), and one bridge company. The one wheeled company provides situational obstacle capability and the ability to reinforce engineers with the reserve or maneuver brigades. The reserve battalion is supported by one divisional engineer company. The reserve is positioned for immediate employment by helicopter or truck. The engineer unit provides gap-crossing capability.

One engineer battalion supports each of the three maneuver brigades. The division engineer battalion (-) supports the 1st brigade with one divisional company, one corps wheeled company, and one CSE platoon. The battalion HQ (-), under the control of the executive officer, coordinates all engineer activities in the brigade sector. The second corps wheeled engineer battalion, reinforced by one attached wheeled company and one divisional engineer company, supports the 3d brigade. Division authorizes 3d brigade to convert one engineer company to infantry for use in either SP35 or SP36, Corps approves converting one corps engineer company to infantry. The divisional engineer battalion commander remains the division engineer. He reinforces the ADE section in the main CP and controls engineer operations through the ADE, TAC CP engineer, and rear area GS corps engineer battalion HQ.

Division delegates authority to emplace FASCAM in turning, fixing, disrupting, and blocking obstacle zones to the brigade commanders as well as authority to execute planned FASCAM on all lanes and gaps. The division commander reserves, however, execution authority on division-specified lanes and gaps. The division G3 approves planned targets or situational obstacles using FASCAM outside of zones to protect flanks and slow enemy forward movements on the battlefield. FASCAM is primarily planned to develop targets for other fires to exploit.

Air Defense Artillery

The USAF maintains air superiority over the theater in this example. The enemy air force, although striving for localized air superiority above its ground attacks, has had limited success. The enemy's most effective air weapons have been attack helicopters to support attacks at the FLOT. Therefore, the enemy air threat is low in the division rear area but constitutes a significant threat to forward units.

The major air avenue threats in the division sector approach the FLOT frontally, following the valleys. These are all attack helicopter routes. The major high-performance aircraft air avenue parallels the interdivision boundary in the more open terrain area.

Initially, the covering force is supported by battery B (-), which is OPCON, and one attached Vulcan/Stinger platoon from battery A.

The attached platoon stays with the divisional cavalry squadron as the division reserve, following the covering force fight. The OPCON corps light cavalry squadron is supported by an organic Vulcan/Stinger platoon from the corps light cavalry regiment. When the covering force withdraws, battery B (V/S) (-) is placed in DS of 2d brigade. The battery B HQ assumes control of its 1st platoon which was left in support of the 2d brigade.

The 3d brigade is supported by battery C (V/S) in direct support. It orients on the attack helicopter and high-performance aircraft avenues. This battery also supports the withdrawal of the corps light cavalry squadron from the CFA.

The 1st brigade is supported by battery A(V/S) (-) because it principally has only one attack helicopter air avenue entering directly into its sector. Battery A must also protect on the north side of EA DIRT against air avenues originating in the 2d brigade sector.

ADA protection for the remainder of the division relies upon passive AD measures, success of the USAF counterair campaign, and incidental coverage from the corps ADA weapons systems. Critical CSS and aviation assets with low recuperability are located in the DSA under the potential corps ADA coverage.

The towed Vulcan and Stinger systems are located forward in the brigade areas. As the first priority, they must counter the attack helicopter threat; second, the high-performance aircraft. Towed Vulcans are positioned to provide effective ground fire support to infantry units while moving. They are also positioned to add to the volume of massed fires in the EAs. The division ADA defense plan places great reliance upon the USAF counterair operations.

The terrain forces the aircraft down parallel valleys into the FLOT or above the terrain where they will be easy to detect and engage. The USAF will counter high-performance aircraft. The division ADA systems' priority is attack helicopter defense.

All air defense assets, except for the covering force and reserve ADA units, are placed in DS. The ADA battalion HQ advises the division commander on AD systems employment, support relationships, and air threat status. This HQ is responsible for the division's early warning system.

Priority of support is to the 2d, 3d, and 1st brigades, and then the reserve. The covering force brigade is the first priority until the division commander withdraws it.

Combat Service Support

In this defense in depth, the CSS units are located well to the rear of their supported units' sector. Noncritical elements may be moved back from the BSAs to the DSA for rear area security purposes. Positioning of units is dictated first by the support needed to the immediate fight. The

second consideration is the enemy infiltration threat. Wherever the units support from, they must cluster together for security purposes. Throughput distribution is desirable.

The FSBs are located on the brigade rear boundary since the last defensive positions are in the vicinity of PL BANK. The 3d brigade's FSBs BSA is partially located in the division rear area. Control of the area is exercised by the 3rd brigade FSB commander. (See Figure 4-12, page 4-30.)

The defense in depth concept may leave infantry units in contact throughout the depth of the sector. This makes CSS actions more difficult to execute because of the distances, multiple unit locations, and enemy actions. The brigades' concepts of operations are fully coordinated with the supporting FSB. The DISCOM and G4 are informed of requirements and shortfalls, Class I, IV, V, and VIII stocks are prepositioned in known-use locations before the covering force withdraws. Stocks are placed in all positions where infantry decisive engagements are envisioned, such as BPs and SPS along PL BANK. Artillery munitions are prepositioned to support massed fire missions into EAs.

Resupply by vehicle is difficult due to the limited road network and poor-quality roads. Resupply by a prepackaged push system delivered by helicopter may be the norm. Class VIII stocks are maintained in battalion trains. Landing zones are established for each BSA and for battalion trains. These LZs also support aeromedical evacuation.

Medical evacuation is difficult due to the road conditions. Helicopters evacuate casualties to supporting corps mobile Army surgical hospitals in the division rear and evacuation hospitals (CS hospitals) in the corps rear area. These are located along corps MSRs in division rear with dedicated LZS. Ground evacuation is planned for bad weather periods,

Corps support group units are located in the corps support area near the DSA. These units provide critical heavy maintenance support to the supporting corps artillery and engineer units. Corps maintenance support teams are formed and moved forward to BSAs for more responsive support. The forward corps support battalion (CSB)

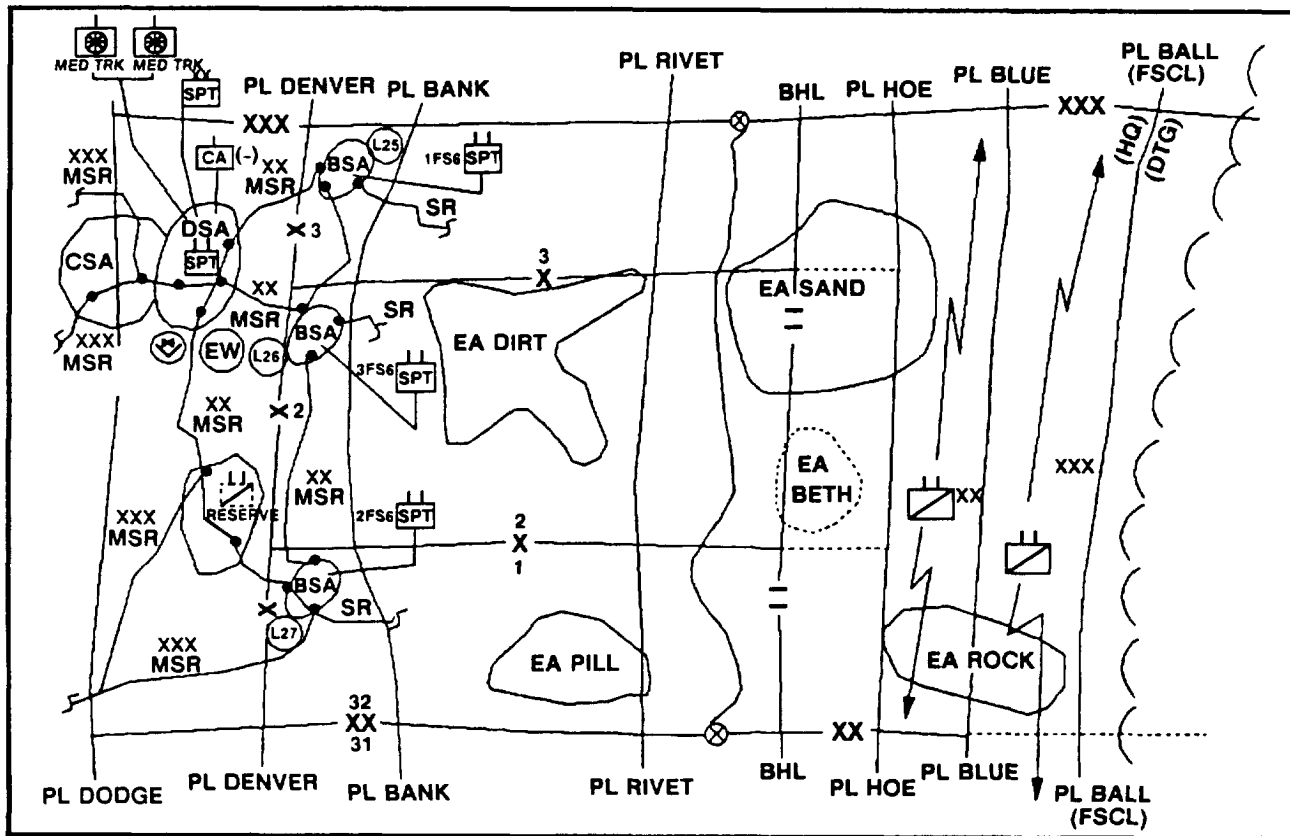

Figure 4-12. Areas defense in sector: combat service support

provides reinforcing support to MSBs and FSBs to enable them to support the corps organizations supported in the BSA and DSA.

Movements in the division rear are strictly controlled by the division MCO. The limited road network must be managed for efficiency in efficiency actions and unit movements. If necessary, division MSRs are extended forward into the brigade sectors and controlled by the division.

Intratheater airlift (C130 aircraft) and corps aviation support (CH-47 helicopter) are planned to maintain steady CSS flows to relieve the limited road network. The division G4 and DISCOM commander must plan current and future C130 airfields and helicopter LZs. These critical engineer tasks require considerable planning, materials, and equipment.

Nuclear, Biological, and Chemical

One corps smoke and decontamination company is attached to the light division. Because the

enemy has already used artillery and rocket-delivered chemical munitions, the NBC priority is chemical decontamination. Smoke requirements are satisfied by using artillery or mortar smoke munitions or smoke pots.

Four dual-purpose platoons are available in the division sector. One dual-support platoon is positioned in each infantry brigade sector. The company HQ and the fourth decontamination platoon are positioned near the DSA. Each provides general support on a geographical basis. Decontamination sites are selected to the rear of the brigade sectors because of the defense in depth. These positions are relatively secure behind PL BANK where the enemy will be held. Alternate positions are selected to initially support the withdrawal of any contaminated covering force units. These positions are also true alternate positions in case one of the primary sites becomes unusable.

Priority of decon support is, in order, artillery units, CSS units, combat zone (CZ) facilities,

engineer equipment, and infantry battalions. No decontamination support is provided to the covering force. On order, the first priority for decontamination is the reserve battalion.

Command and Control

The light division TAC CP locates in the 2d brigade sector near the brigade CP. This brigade is the division's main effort following the security force units' withdrawal. From that location, the TAC CP can see the critical battle unfold in the CFA into EA SAND. It is also well situated to control the battle if the enemy's main effort comes into EA BETH or EA ROCK. The location is driven by the need to control changes, not just to be near the main effort. The TAC CP increases its security by locating near brigade units.

The main CP faces very little air threat, but artillery is a danger. Therefore, it is located beyond artillery range in the division rear. It locates itself near communications nodes and the reserve unit to facilitate planning and executing branches. The main CP derives security by locating near reserve units. Military police will not be used for security.

The main CP synchronizes deep operations to the close operation to support the commander's vision. It also updates and executes sequel and branch operations plans to the current operation so that the two can meet at some point in time and space. This is called transition operations. The planning and control of collateral operations is also critical for cross-FLOT attacks, LRSD operations, intelligence collection, counterfire, SEAD, and movements. The G3 in the main CP is the principal staff officer for planning and synchronizing collateral and transition operations.

The rear CP collocates with the DISCOM HQ in the DSA. Its security is provided by clustering with DISCOM units. The rear CP plans and controls terrain management, rear area security, sustainment, and movements control. Movements control and sustainment operations are shared actions with the G1, G4, and DISCOM. Terrain management and rear area security are the primary roles for the rear G2 and G3. These are critical in this example since the terrain is rough and the road network is poor and limited. Firm and proactive control is required.

MP Operations

The infantry division is the corps' supporting effort and provides only one corps MP GS platoon to the division. However, the corps MPs provide battlefield circulation control on corps-designated MSRs to the DSA and evacuate EPWs from the division EPW collection point.

The division band operates the EPW collection point in the division rear area. Band personnel are supervised by the MP company HQ. The attached infantry platoon is located with the MP company HQ and is truck-mounted. The infantry platoon augments the MP company's combat power response to Level II rear area threats and conducts other rear area security operations. After the division security force withdraws, the ground surveillance radar (GSR) platoon (-) supports the MP company rear security operations with one GSR squad. The four MP platoons, three division and one corps, are assigned area responsibilities. They are GS to the division and controlled by the MP company HQ.

The first MP platoon's area is the 1st brigade sector extended into the division rear area to PL JOE. The second platoon's area is the 2d brigade's sector extended back to PL JOE. The third platoon's area is the 3d brigade's sector extended back to the division rear boundary. The fourth platoon's area is in the division rear area bounded by the division rear boundary, division and corps left boundary, PL JOE, and PL PARIS.

The priorities for the four MP platoons are battlefield circulation control, rear area security, EPW operations, and then law and order operations. Corps MPs provide battlefield circulation control on corps-designated MSRs. Division-controlled MPs provide traffic circulation and control on division and brigade MSRs or supply routes (SRs) forward to battalion trains areas. Rear area security missions provide support, in order of priority, to MLR units, Class V points and convoys, attached helicopter units, lift helicopter units, and other CSS units. Division MPs will escort EPW movements only from brigade collection points to the division collection point.

The MP assets are kept under division control because the number of MP units is inadequate for the mission tasks. The division must intensely

manage the limited road network as well as counter an enemy rear area threat. The MP units perform security operations to intercept or discover enemy special operations forces or small unit infiltration. The attached infantry platoon provides added combat power for this mission.

MOBILE DEFENSE

Mobile defense orients on destruction of the enemy by using a combination of fire and maneuver, offense, defense, and delay. The defender places minimum forces forward and creates powerful strike forces that catch the enemy as he attempts to overcome that part of the force dedicated to the defense. The defender delays the enemy causing him to focus on the wrong objective, overextending his resources, and exposing his flanks. This leads the enemy into a vulnerable posture in terrain that diminishes his ability to defend against the counterattack of a larger, mobile strike force. The mobile defense sets up large scale counterattacks that allow the defender to destroy enemy forces, gain and retain the initiative, transition to the offense, and move into exploitation and pursuit operations.

In this example, a third world country is being threatened by invasion from a neighboring country. The invasion appears to be imminent. Diplomatic efforts to resolve a long-term border dispute are at a stalemate. The hostile country has started national mobilization and continues to escalate armed forces along the adjoining border.

The threatened country has formally requested that the US military intervene under the provision of a long-standing treaty agreement. In response to the country's request and the potential adverse consequences of the hostile country becoming the regional dominant power, The National Command Authorities (NCA) has directed the deployment of a JTF into the crisis area as a show of force.

The JTF's maneuver forces consist of a light division with an attached armored brigade. The infantry division, executing its emergency deployment sequence, begins air deployment into the host country within hours of notification. The attached armored brigade closed into the division

lodgment area within days of notification. This deployment was accomplished by a combination of strategic sea and air lift. The lodgment is located in the vicinity of the country's only airport capable of handling C-141 and C-5A aircraft within the disputed area. Forces currently are preparing to move forward from the lodgment area to establish defensive positions in support of host country forces.

Intercepted high-level message traffic reveals the hostile country is planning to commence its invasion when it completes mobilization. The invasion force's mission is to rapidly push as far forward into the disputed area as possible and secure selected objectives within the disputed area. On securing selected objectives, the government intends to appeal quickly to the United Nations (UN) for a cease-fire and negotiate a more favorable border settlement during UN negotiations. The hostile government is gambling that this action will result in obtaining new territory rich in natural resources, demonstrate its country's defiance of US support, and establish it as the dominant regional power.

The hostile country has significantly increased its offensive capability over the host country within the past four years. Its ground forces comprise four active infantry divisions, a border defense force, and one separate tank regiment which has recently been upgraded with T-72s. Each infantry division comprises two infantry regiments and one motorized rifle regiment with supporting artillery both at the regimental and divisional levels. The air force (fixed wing) is limited at best and should not present any significant obstacle to the deployed JTF forces. However hostile forces have enough rotary-winged capability to lift two battalion-sized units in a single lift.

The host country has three infantry divisions and an internal border security force available. Of the three divisions, two are active and the third, an auxiliary division, is manned with reservists during national emergencies. Limited armored vehicles are found in the border security forces only. The country's air force is comparable to the hostile air force, offering limited offensive capabilities.

Anticipating an invasion, the host nation has deployed both of its active divisions along their threatened border to reinforce their border security forces. Increasing incidents of border violations by the hostile ground forces have resulted in increasing engagements. These border violations appear to be probing missions to identify unit locations and force density along potential invasion routes.

The border terrain between the two countries is mountainous. One major valley system has natural mobility corridors which support motorized vehicles. Vegetation varies from sparse in the low, open areas to double and triple canopied in jungle and mountainous areas.

The JTF commander intends to defeat the invasion force by establishing his AO to the rear of the existing host nation's border defensive positions along the main invasion corridor. He intends for the host nation to establish initial contact with the lead invasion forces before committing JTF ground forces in direct contact. This action will demonstrate the invading country's aggression and the host country's resolve against the invading country. Once the invasion commences, the JTF commander intends to quickly develop the situation to contain the main invasion force and destroy the enemy units with swift, overpowering forces. Upon halting invasion forces, JTF elements will quickly transition to the offense, forcing the enemy to withdraw and reestablish the recognized border within the JTF AO. Quick success against enemy invasion forces will defeat the enemy's national will to continue aggression. During this operation, the airport activities within the lodgment area must not be interrupted. Once the border is reestablished and hostilities have ceased, the JTF will posture to redeploy rapidly.

Maneuver

The division commander establishes a mobile defense along the main invasion corridor behind the host country's border defensive positions, to destroy the main invasion force that penetrates border positions. The division delays and neutralizes the invasion forces through the depth of the division's sector. Two brigades positioned forward defend in sector to delay advancing

forces, prevent infiltration within the division's sector, and attrit the enemy. This causes the enemy to commit his reserve forces early and to overextend his main attack. (See Figure 4-13, and Figure 4-14, page 4-35.)

The 3d brigade establishes a blocking position to the rear of the forward brigades that contains those forces that penetrate the defending brigades. This fixes the enemy forces, creating the opportunity for the armored strike force to maneuver to destroy the contained forces. The lodgment security is vital to the JTF operation and is secured by a two-battalion force with augmentation from host forces. The desired end state is the destruction of the attaching enemy's invasion forces and a quick transition to the offense, forcing withdrawal of the hostile country and reestablishment of the international border.

Deep operations for the division initially are limited in depth due to the JTF-imposed "no cross-border operations" restriction. Close coordination with in-place host country border forces is established to designate EAs forward of the division. Deep fires neutralize enemy artillery support, decreasing follow-on forces' operational tempo. This action provides time for the defending brigades to concentrate their combat power without interference by follow-on reinforcements. The aviation brigade disrupts and destroys enemy follow-on motorized and armored forces supporting the forward defending brigades. Deep fires and obstacles provide time and help seal off the contained enemy force, thus supporting strike force attacks.

The division cavalry squadron screens forward of the two defending brigades, establishing contact with the host country's border security forces forward of the division's sector. The cavalry establishes contact with those advancing invasion forces that penetrate the border security and maintain contact to provide early warning for the lead brigades. As the enemy approaches the division's sector, deep fires are committed to disrupt, attrit, and alter the tempo of the lead regiments. Maintaining contact with the enemy, the cavalry delays to the battle handoff line, moves through the defending brigades, and establishes rear flank screens. These screens are positioned along both division flanks behind the forward brigade sectors

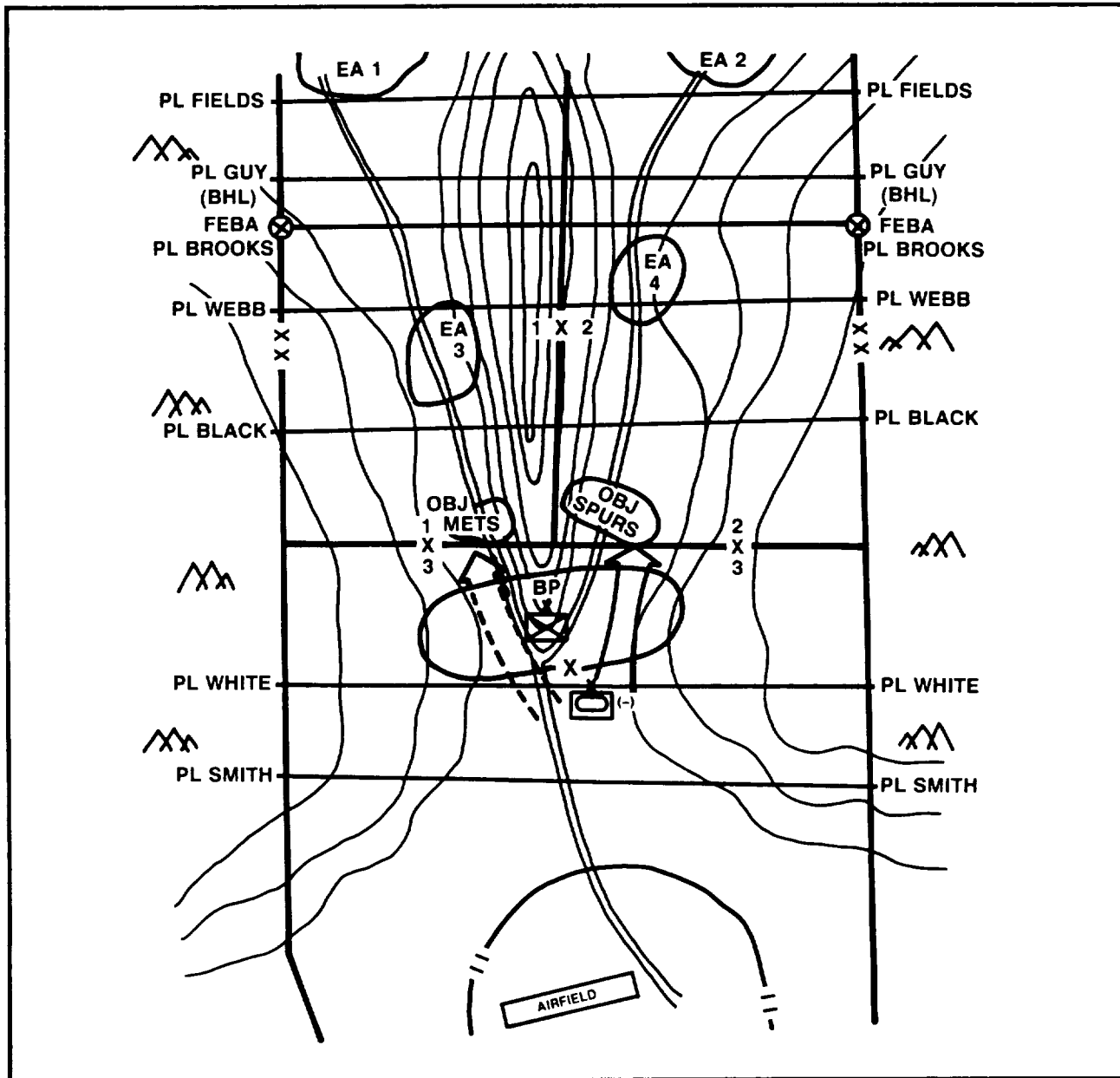

Figure 4-13. Mobile defense: concept of operations

to detect infiltrating enemy forces that threaten the lodgment area.

The division establishes a mobile defense with two infantry brigades defending in sector. The third infantry brigade establishes blocking positions to the rear of the two delaying brigade sectors to contain penetrating enemy forces. The mobile defense strike force, consisting of the armored brigade, locates behind the blocking

brigade to rapidly attack and destroy enemy forces in designated objective areas forward of the blocking positions. Two infantry battalions provide lodgment security during the operation.

Designated EAs within the brigades' defensive sectors facilitate massing of combat power during the delay to attrit the enemy. The 1st and 2d brigades establish mutually supporting positions constructed in depth in their respective

<i>1st Bde (-)</i>	<i>2d Bde</i>	<i>3d Bde</i>	<i>Armd</i>
Inf Bn	Inf Bn	Inf Bn	Armd Bn
Inf Bn	Inf Bn	Inf Bn	Armd Bn
FA Bn (105T) (DS)	Inf Bn	Inf Mech Co	Inf (Mech) Bn (-)
Engr Co (Lt)	FA Bn (105T) (DS)	FA Bn (105T) (DS)	FSB
Chem Plt (Smk)	Engr Co (Lt)	Engr Co (Lt)	
ADA/Plt	Chem Plt (Smk)	ADA Plt	<i>Division Troops</i>
MI Co (-)	ADA Plt	MI Co (-)	Inf Bn
GSR Tm	MI Co (-)	GSR Tm	Inf Bn (-)
Inter Tm	GSR Tm	Inter Tm	Inf Co (Reserve)
PSYOP Tm	Inter Tm	PSYOP Tm	MP Co
CA Tm	PSYOP Tm	CA Tm	ADA Bn (-)
FSB	CA Tm	FSB	Sig Bn
	FSB		MI Bn (-)
<i>Avn Bde</i>		<i>DISCOM</i>	Engr Bn Cbt
Atk Bn	<i>DIVARTY</i>	MSB	PSYOP Co (-)
Div Cav Sqdn	FA Bn (155T) (GS)	CA Co (-)	Chem Co (Smk Decon)

Figure 4-14. Task organization

sectors to detect and impede enemy movement. Defensive positions and integrated obstacles create EAs, allowing massing of available artillery and mortar fires. Available CAS and attack helicopters augment supporting fires. The restrictive terrain and emplaced obstacles limit enemy armored forces to infantry fire support. The 3d brigade contains penetrating forces by occupying blocking positions to the rear of the two forward brigades and sealing off the division sector. This causes the enemy to focus and concentrate his forces on 3d brigade's blocking positions. As the enemy attempts to penetrate the blocking positions, his flanks become exposed and vulnerable for counterattack. At this moment, the armored brigade conducts a swift counterattack into the enemy's flank, destroying the forces forward of the blocking positions in designated objective areas.

Lodgment security provided by the two infantry battalions from the 2d and 3d brigades prevents interruption of the airfield and lodgment support activities from infiltrating forces. One company within the lodgment is designated as the division reserve.

Upon destroying the enemy's main attack in the division sector, the division rapidly transitions to the offense, clearing the sector of remnant units, forcing enemy withdrawal, and halting his

invasion. Once the existing border is reestablished, the division closes in the lodgment area and prepares for deployment.

Fire Support

Fire support assets mass fires to disrupt and destroy moving enemy units in engagement areas. Infantry units in prepared positions close fires, and deep operations canalize the enemy into those designated EAs. The DIVARTY coordinates the positioning of all fire assets so that massed fires and time-on-target missions are possible across the division front.

Intelligence

Intelligence operations provide early warning and lead time for maneuver forces by confirming or denying enemy COAs. The LRSD teams are positioned to observe NAIs, TAIs, and DPs. The GSR teams are attached for early warning both with forward maneuver brigades and to units providing lodgment security. The division's developed collection plan supports the developed PIR which is critical to the targeting process and the enemy's destruction.

Mobility and Survivability

The division commander specifies general obstacle zones to fix the enemy to increase attritions, cause enemy supporting artillery to deploy,

and set and slow the enemy's tempo. The division specifies disruption zones behind EAs to enhance targeting and deep fires and to slow the tempo of follow-on forces. One fixing zone is designated forward of the 3d brigade to assist in the enemy's containment. The obstacle plan facilitates delaying the enemy forces and develops the conditions that cause the enemy to expose his flanks, providing opportunity for strike force attacks.

Air Defense

The division is operating in a low air threat environment. Stinger teams are attached to each maneuver brigade and the battalion (-) is located within the lodgment area. These assets provide integrated ADA coverage against potential enemy helicopter operations.

Command and Control

Division rear and main CPs locate within the lodgment area. The rear CP controls the divisional activities within the lodgment to include security. The TAC CP locates forward in the division sector behind the blocking brigade. This forward positioning facilitates synchronizing the delay of the two forward brigades and the control of the armored brigade when committed.

TRANSITION TO THE DEFENSE

While the defense's immediate purpose is to defeat an enemy offensive operation, a force may have to defend because it is unable to continue the attack—has reached a culminating point. According to FM 100-5, this is a point where the strength of the attacker no longer exceeds that of the defender and, beyond which, continued offensive operations risk overextension, counterattack, and defeat.

Normally a force defends to develop favorable conditions for an attack or to act as economy of force in one area to mass overwhelming offensive

combat power in another area. Specifically, the defender may have to--

- Buy time.
- Hold a piece of terrain to facilitate other operations.
- Keep the enemy preoccupied in an area.
- Build up forces.

When attacking units cease their attack and are required to defend, they have two basic options. One is to commit forces and push forward to claim enough ground for a security and or covering force area (that is, beyond the majority of enemy artillery range fans). The second option is to fall back to defensible terrain to establish a security and or covering force area, establishing the FLOT generally along the attacking force's line of advance of final objectives. In both options, the FLOT is the forward edge of the security area. The FEBA is the forward edge of the main defensive area. (See Figure 4-15.)

Unfortunately, the first option results in loss of additional personnel and equipment and the expenditure of more resources. The security area often lacks depth. Additionally, the enemy force will probably accurately template the friendly FEBA trace and engage with artillery. These actions increase loss to friendly personnel and equipment.

In many cases, option 2 is the better option. Commanders pull back the bulk of their forces to defensible terrain and establish the MBA on ground the attacking force already owns rather than under the threat of enemy artillery. The forward edge of the security area (the FLOT) remains along the line of contact. The depth of the security and or covering force area is based on METT-T and the operational plan.

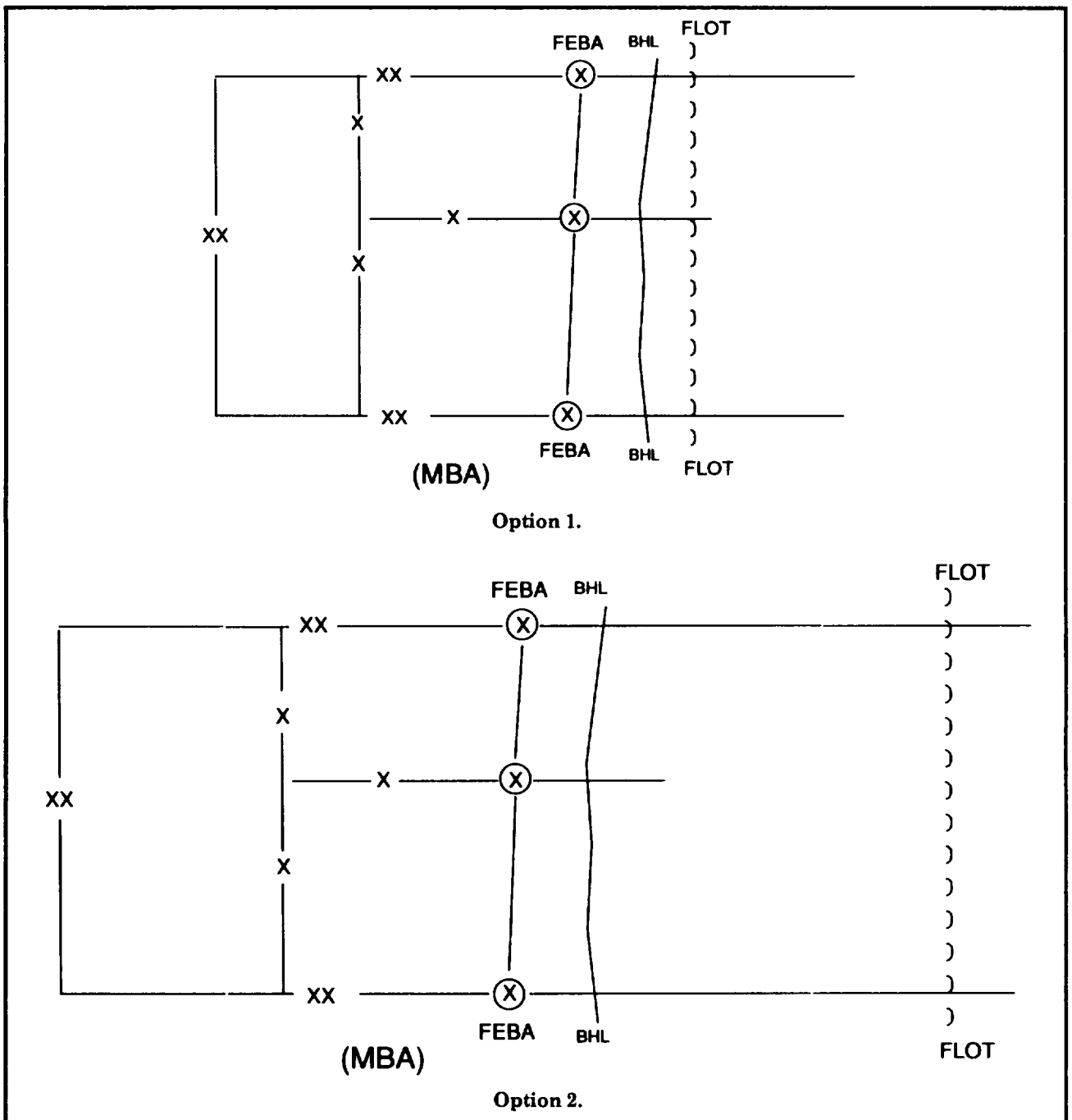

Figure 4.15. Transition to defense options

CHAPTER 5

CONCURRENT OPERATIONS

Concurrent operations are those functions which are routinely conducted as part of any division operation. They contribute to overall combat effectiveness, but are not stand-alone actions such as offensive or defensive operations. The division conducts them to enhance overall operations. This chapter provides some examples of techniques for planning and executing concurrent operations.

REAR OPERATIONS

The division's rear operations include all activities conducted to the rear of elements in contact to ensure freedom of maneuver and sustainment of close, deep, and rear operations. Rear operations comprise four interrelated functions:

- Sustainment.
- Movement.
- Terrain management.
- Security.

Area damage control supports all four functional areas and is addressed separately.

Figure 5-1 shows how these functional areas interrelate. The rear CP synchronizes these key rear area activities.

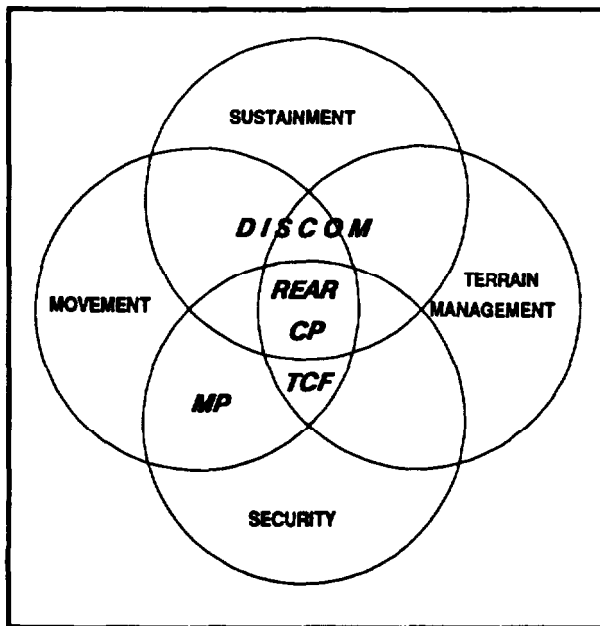

Figure 5-1. Rear operations functional areas

The division conducts rear operations within the division's rear area (DRA). The DRA extends from the rear boundaries of forward brigades to the division's rear boundary. It contains a large number of CS and CSS units, chemical munitions and delivery means, C² headquarters, and non-committed combat units. It may also contain joint facilities, such as air bases, and host nation facilities and population centers.

The ADC-S is the rear operations commander. He is responsible for conduct of division rear operations. The direction and synchronization of sustainment operations is the responsibility of the rear commander. He and the rear CP staff ensure that sustainment operations respond to the needs of the division.

The rear commander commands and controls rear operations through the division rear CP. The CP has three cells: a HQ cell, an operations cell, and a CSS cell. The rear CP normally collocates with the DISCOM CP for security, life support, and ease of coordination. However, both CPs are separate and distinct. See Chapter 2 for a detailed discussion of the rear CP.

Sustainment

The basic mission of CSS units is to sustain the battle. Their sole purpose is to maintain and support division soldiers and their weapons systems before, during, and after operations. Sustainment functions consist of those actions that man, arm, fuel, fix, move, and sustain soldiers and their systems. Maintaining the capability to sustain the force continuously is the focus of rear operations. The rear operations functions of movement, security, and terrain management, as well as area damage control, must be integrated with sustainment to provide synchronized logistics support.

Sustainment planning is the responsibility of coordinating staff officers with personnel and logistics responsibilities and special staff officers with CSS responsibilities. The G1 or AG plans and coordinates those measures necessary to man the force. The G4 plans and coordinates (with DISCOM) measures to arm, fuel, and fix the force. The DTO plans movement control and highway regulation. The G5 assists in obtaining host nation resources such as civilian labor and supplies; he also helps coordinate these activities. Personnel and logistics staff officers perform their planning and supervisory functions primarily from within the CSS cell of the division rear CP. They collocate with the DISCOM CP to aid in logistics planning, coordination, and execution. Their location also helps integrate the functions of terrain management, movement, security, and area damage control.

DISCOM, the logistics operator of the division, translates logistics planning into logistics support. DISCOM provides supply, maintenance, HHS, and transportation assets to the division.

The DISCOM S-2/3 section is the commander's interface with the division rear CP. The S-2/3 section develops the DISCOM critical asset list and recommends its priorities to the commander in concert with the division materiel management center (DMMC). Once the list is approved, the S-2/3 section furnishes it to the rear CP operations cell where it is continually monitored and adjusted.

The S-2/3 section is also the key interface with supporting criminal investigation division (CID) elements for the command's logistics security (LOGSEC) operations. As the DISCOM link with the rear CP, the S-2/3 section maintains an operations map and updates other staff officers on the current situation. (For detailed discussions of CSS sustainment operations, see FM 63-2- 1.)

Movement

Movements are generally divided into two categories—tactical and nontactical. Tactical movements are combat units moving to or from close or deep operations. Nontactical movements include all other types of movement.

Movement includes planning, coordination, and synchronization of mode operations, terminal

operations, and movement control. Movement is inherent in all combat, CS, and CSS functions, tying sustainment and all other battlefield operations together.

Movement makes sustainment possible. Supplies and personnel replacements constantly move from the sustainment base at corps (and EAC) into the DRA and then forward to support close operations. Casualties and damaged equipment are evacuated from the forward area for treatment or repair and returned. Movements take place between the forward brigade areas, the DRA, and the corps rear area. They also take place laterally within the DRA.

The division G3 at the main CP plans and directs all tactical movements. The rear CP operations cell executes the G3's priorities in deconflicting and controlling movements to ensure movements support close and deep operations.

The rear CP operations cell controls nontactical movements in the DRA as well as the tactical maneuver of response forces and the TCF. It monitors and deconflicts movement of nondivisional forces through the DRA. It ensures necessary routes are cleared and additional CSS support is available as needed. The rear CP operations cell coordinates CS resources, to include engineer, NBC, reconnaissance, and chemical decontamination support. It also coordinates MP support with PM operations at the rear CP for movements within the DRA.

The rear operations cell also deconflicts tactical and nontactical movements within the DRA. It enforces movement priorities and directs the use of alternate routes to lower priority traffic. The operations cell must coordinate closely with the G3 at the main CP, and with the DTO, DISCOM MCO, and provost marshal to ensure tactical movements are not hindered.

The G4 designates MSRs. He determines MSR conditions (red, green, and yellow) based on information received from users, MPs, and engineers. He maintains the status, and expected recovery time, of those routes which are not green. A timely exchange of information between the military police, engineers, and G4 is essential.

The DTO and CSS cell of the rear CP plan and coordinate all nontactical movements. The DTO coordinates movement priorities with the rear CP. On approval of priorities by the division's rear operations commander, the DTO provides them to the DISCOM MCO.

The DTO and CSS cell of the rear CP plan and coordinate all nontactical movements. The G3 provides movement priorities from which the DTO deconflicts nontactical movement requests and issues movement orders. The DTO and G3 operations cell deconflict tactical and nontactical movements. They plan movement of supplies and material from the DSA forward to BSAs and back. They also coordinate CSS movements between the corps rear and DSA, or, in the case of throughput, directly to BSAs.

The DISCOM MCO controls division motor transport assets for CSS. He ensures established movement priorities are followed. The MCO requests additional transportation from the DTO if requirements exceed DISCOM assets. The DTO, in turn, recommends tasking other assets or requests COSCOM support to resolve the shortfall.

The CS and CSS units execute nontactical movement and assist with tactical movements. Through coordination with the DTO, movement control officer, and the rear operations cell, they ensure that convoys receive necessary security, road congestion is minimal, and supplies reach their required locations at the right time.

If the division does not coordinate tactical and nontactical movements, road congestion can foil the best plans. This degrades the ability to deliver supplies and replacements to maneuver units or evacuate casualties and damaged equipment. Tactical movements normally receive priority over nontactical movements, (FMs 55-2 and 55-10 discuss movements planning and execution in greater detail.)

The division rear CP establishes a process of tracking convoys in the DRA and from the division rear boundary to their destination in the division area. Further, it--

- Monitors LOCs to determine problems in movement flow.

- Develops alternatives to ensure movements remain constant.
- Keeps transportation users informed of available assets.
- Programs back-haul availability to cut down on delayed returns.
- Directs MSR maintenance and security.
- Processes convoy clearance request for units requesting movement on division's MSRs.

Terrain Management

Terrain management demands highly centralized planning and control. The major problem in positioning units within the DRA comes from the competing demands of mission and security. Positioning of units in the DRA requires a fine balance between the needs of units, the requirement to support the concept of operations, and the need to provide security to units. Terrain management should facilitate current and future operations. Faulty terrain management can result in congestion, interruption of rear area traffic patterns, and degradation of support operations.

Terrain management for the DRA is the responsibility of the rear CP. The operations cell manages terrain in coordination with the CSS cell, major subordinate commands, and separate units. Terrain management involves all real estate in the DRA. Locations of bases, base clusters, MSRs, key facilities, risk areas, TCPs, and target reference points are posted on the situation map. The map is used for terrain management and movement deconfliction and control.

Terrain management requirements should be analyzed using the factors of METT-T. A unit's mission must be analyzed to determine specific terrain requirements. Field artillery units must be within range of intended targets; transportation units should be near road networks; supply units, near LOCs. Unit missions must also be evaluated to determine their importance to the division mission. Once unit missions and contributions to the division operation have been analyzed, conflicts between unit requirements can be resolved, and units positioned.

A continual IPB of the rear area will provide much of the data needed to accurately assess terrain management needs. The rear CP operations cell uses the intelligence estimate and other intelligence products from the main CP to analyze enemy capabilities and determine possible threats. If a significant air assault threat exists, CSS units should be positioned away from likely landing or drop zones. Combat units, such as the division reserve or TCF, may be positioned close to likely enemy LZs to counter the threat at its most vulnerable time-during insertion.

The rear CP operations cell should not position CSS units on enemy air or ground avenues of approach or adjacent to likely threat objectives. However, it should position units to provide reconnaissance and surveillance of these avenues as part of security and counterreconnaissance actions.

CSS units have unique terrain requirements. When possible, they should be near established air, road, rail, and water LOCs to aid in mission accomplishment. Positioning must simplify receipt of supplies and materiel from higher echelons and ease their movement forward to the MBA. Positioning must also make evacuation, repair, and return of damaged equipment easier.

The rear CP operations cell analyzes the terrain to determine trafficability, facilities available, and natural obstacles which can support DRA security or hinder sustainment or movement operations. The CSS cell and DISCOM ensure that terrain managers in the operations cell are aware of terrain needs of divisional and corps CSS units.

Terrain impacts on mission effectiveness. A maintenance unit in a built-up area with adequate power, hardstand, and civilian resources can repair material more efficiently than under field conditions. The HHS activities need trafficable roads, shelter, warmth, and proximity to LZs to receive, care for, and evacuate casualties. Supply units require storage space and adequate room to disperse. The G5 coordinates facilities with the host nation and the rear CP.

All CSS units require transportation networks which connect them with sources of supply and support and with their customers. Routes

selected should be able to sustain heavy traffic in all weather conditions. They should accommodate the expected traffic volume to eliminate congestion and avoid choke points. Routes should not conflict with tactical maneuver plans. Planners must identify alternate routes and develop procedures to switch nontactical traffic to them as needed. During offensive operations, the operations cell chooses unit locations to extend supply routes and minimize changes to division and corps CSS transportation plans.

The G3 in the main CP positions maneuver and fire support assets based on the concept of operations. This may include units in the DRA such as the division reserve and aviation brigade. Once he makes these tactical positioning decisions, the rear CP (in coordination with DISCOM and G3) positions CS and CSS assets in the DRA.

Planners in the rear CP must know how the division is task-organized and which units (divisional, corps, EAC, or host nation) are located in the DRA. The division's rear operations cell establishes priorities for terrain and maintains them based on unit missions within the DRA.

After initial positioning, the operations cell monitors the tactical situation. It directs or responds to requests to position and reposition units in the DRA to enhance continuous support and survivability. This centralized management process prevents positioning conflicts, maintains an integrated security plan, ensures unit survivability, and improves OPSEC.

Whenever the division moves, either forward or to the rear, the rear CP plans for gaining additional terrain within the DRA as the tactical situation dictates. The G3 at the main CP establishes phase lines during offensive operations to indicate future DRA boundaries. He coordinates with the corps G3 for establishing phase lines within the DRA for additional terrain during retrograde operations. Close coordination with the corps rear area operations cell through the corps rear CP liaison is essential. This ensures a logical handoff of terrain management responsibilities.

The G3 operations cell in the rear CP compares terrain preferences with security requirements. It positions CSS units to enhance their survivability. Cover and concealment are keys to

protecting them from detection and attack. Dispersion avoids catastrophic damage from air, artillery, and mass destruction weapons. The commander must weigh this against the advantage of positioning units close enough together to enhance security.

Base Configuration

Numerous units and activities occupy terrain and conduct operations in the rear area. The units and activities shown in Figure 5-2 all compete for usable terrain and facilities.

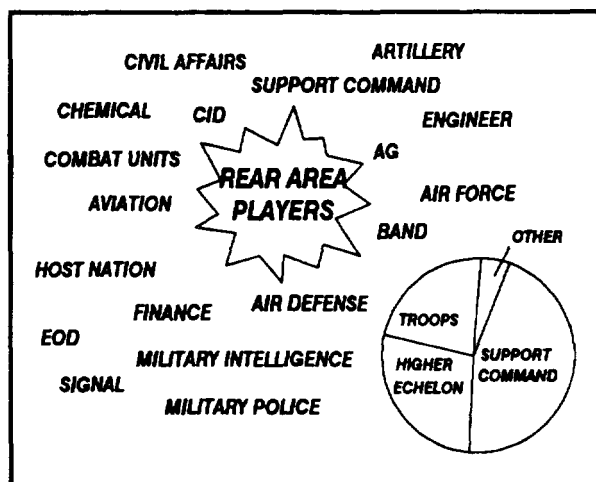

Figure 5-2. Terrain users

The rear CP operations cell plans for units two echelons down. For rear operations, these echelons are base clusters and bases. This means placing units together to form multiunit bases.

The rear CP operations cell designates base commanders. The base commander normally is the senior unit commander when more than one unit is present in the base. However, a medical unit commander, even if senior, is prohibited from commanding a base or base cluster containing nonmedical units (AR 600-20).

Many factors determine which units are grouped into bases and their location. A thorough METT-T analysis, including size and composition of each unit, is required. Medical units should not collocate with units that may be priority enemy targets. They should, however, collocate with units capable of assisting in their defense.

Bases have clearly defined defensible perimeters and entry and exit points. By grouping units

together, they share responsibilities for security, capitalizing on each unit's strengths while minimizing weaknesses. A mix of weapons systems, sufficient personnel for planning and supervising, and adequate communications assets form a viable base. Positioning similar units in different bases, unless it is absolutely necessary to collocate them in the same base, ensures a degree of dispersion.

Bases are represented on situation maps by drawing a line around them similar to an assembly area. This establishes the base commander's AOR. The base is labeled with a numeric designator. The rear CP maintains lists of units occupying specific bases, including types of units, personnel strength, major weapons available, and other information not shown on the situation map.

The base commander's AOR should allow sufficient space for subordinate units to operate, establish perimeter defenses, and conduct surveillance and counterreconnaissance. The line denoting the base should be drawn far enough from its internal installations to allow the use of artillery without endangering the base. For example, DANGER CLOSE range for cannon artillery is 600 meters. The line designating the base should be at least 600 meters from subordinate units.

Most bases are in a base cluster. However, some may operate separately. These separate bases report directly to the rear CP which integrates them into rear security plans. Units in the DRA not designated as bases, such as air defense and artillery firing units or signal sites, should be incorporated under a base cluster commander.

Base Clusters

The rear operations cell establishes base clusters by placing geographically contiguous bases under the control of a headquarters and designating it a base cluster. The base cluster becomes the next higher tactical C² headquarters of those bases. The rear CP may also establish a base cluster for a corps support group operating in the DRA. The corps support group then assigns bases within its cluster to its subordinate units and informs the rear CP of these locations and the information required by the rear CP as to type, composition, and weapons.

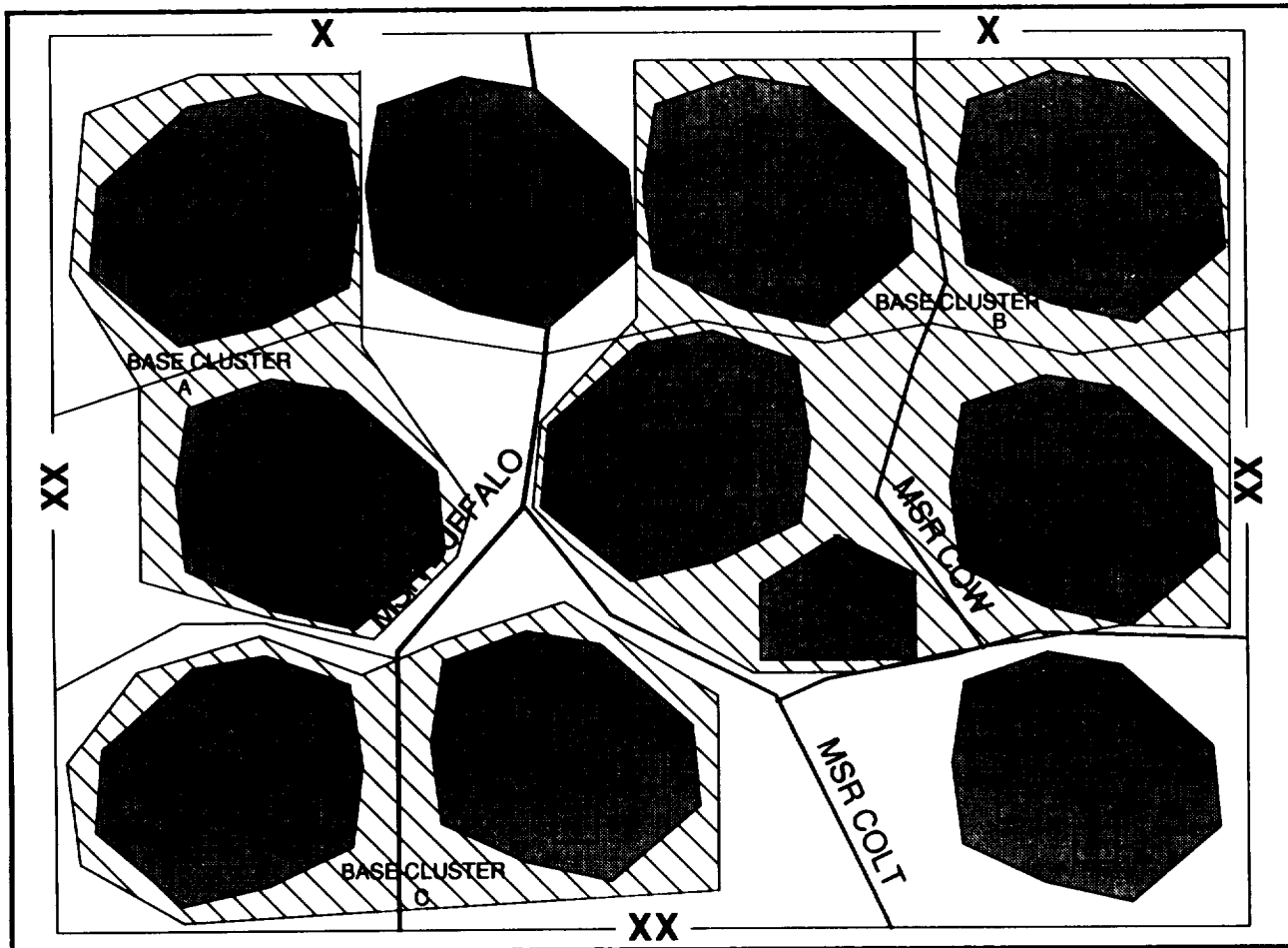

Figure 5-3. Base cluster

The rear CP operations cell should designate, whenever possible, a battalion- or brigade-level headquarters as the base cluster headquarters. Battalions and brigades have organic staffs that can function as the base cluster staff. CSS battalions and brigade-level headquarters have this capability in their TOES with a support operations section for customer mission support activities and a separate operations section for O^2 of internal unit operations. The operations sections function as the base cluster operations center (BCOC). It coordinates terrain management planning and use, and security planning and execution, with the rear CP.

Base clusters are shown on the rear operations situation map by drawing a line around those bases that have been clustered together and placing an alphabetic designator within the area,

Figure 5-3 shows a typical base cluster. The base cluster commander's AOR should provide sufficient area for him to organize his subordinate bases and units and sufficient depth to organize a defense.

The rear CP analyzes the DRA to develop risk areas. Risk areas are areas of terrain that are not useful to the division and provide no advantage to the enemy. By designating risk areas, the rear CP weights the limited MP force within the remainder of the DRA. Occasional overflights or mobile patrols monitor risk areas.

Security

An understanding of the threat to the rear area and a good IPB for the DRA are needed to ensure proactive security operations. The IPB for the DRA determines the potential effects of

enemy capabilities and weather and terrain on rear operations. The specific focus of rear IPB is the enemy's air threats, airmobile and air assault threats, SOF threats, and the counterintelligence threat (agents, sympathizers, and terrorists). This IPB becomes the basis for initial patrol plans and a consideration in selecting base cluster locations. Continuous IPB ensures that the rear operations commander has current intelligence and information for decision making. A detailed discussion of the IPB process for rear operations is found in FM 34-130.

Security of the DRA is a command responsibility extending from the division commander through the rear operations commander, the base cluster and base commanders, to the unit commander. R includes all actions from local defensive measures through commitment of TCFs.

The rear operations commander exercises OPCON over base defense forces, response forces, and TCFs in response to rear area threats. The rear CP operations cell supports the rear operations commander's efforts by—

- Grouping units into bases.
- Forming base clusters when necessary.
- Designating base and base cluster commanders.
- Collecting, analyzing, and approving base defense plans.
- Developing an integrated DRA security plan.
- Approving and coordinating obstacle and fire support plans.
- Positioning response forces and fire support assets.
- Providing continual METT-T analysis of the DRA.
- Providing continual information on the enemy and other matters to units within the DRA.

Units positioned in the DRA normally operate from bases or base clusters which provide a defensive barrier for sustainment. Military police units provide area security around bases and may detect and engage threats before bases becoming involved.

Security operations in the DRA are based on economy of force measures and are designed to provide a graduated response to threat activity. There are three levels of response:

- Level I. Response to threats which base defense forces can defeat.
- Level II. Response to threats which are beyond the capabilities of base defense forces but which response forces can defeat.
- Level III. Response to threats which necessitate a command decision to commit tactical combat forces.

These guidelines should not restrict a commander's response to a threat. He must apply the necessary force to destroy the threat.

Base Defense Forces

Every unit or base is responsible for its own security. It must be capable of detecting and defending against enemy forces. Bases should use both active and passive measures to avoid detection. The base, if detected, must be able to defeat the threat or withstand attacks until assistance arrives.

Base defense is the cornerstone of rear security operations. The unit or base commander—

- Prepares a base defense plan.
- Rehearses all personnel and units within the base on the effective execution of the base defense plan.
- Organizes a reaction force.
- Recommends movement or repositioning of the base to enhance security.
- Coordinates mutual support from other bases or the base cluster commander.
- Coordinates response force operations.
- Adjusts base defenses as the threat changes.
- Determines the base defense status.

Planning and Coordination. Unit and base commanders are responsible for developing and implementing comprehensive security plans to defend their sites and protect their sustainment capability.

In establishing a base defense, the base commander employs the same procedures and techniques maneuver commanders use in developing a perimeter defense. Security is established for 360 degrees and the bulk of combat power is placed on the outer edge of the position. Interlocking fields of fire are used to prevent penetrations of the perimeter. Perimeter defenses must be established in either urban or rural terrain.

Base commanders must ensure they and their subordinate units are aware of other units and bases in their areas of interest and establish limits of fire to prevent fratricide between units. To coordinate indirect fires, base commanders may establish restricted fire areas around subordinate units and restrictive fire lines between units.

Base commanders must coordinate with their base cluster commander or the rear CP to ensure they are assigned sufficient terrain to establish OPs and patrols outside their perimeter. These locations must be integrated with NAIs established by the base cluster commander or the rear CP. Figure 5-4 outlines the elements needed for a viable base defense.

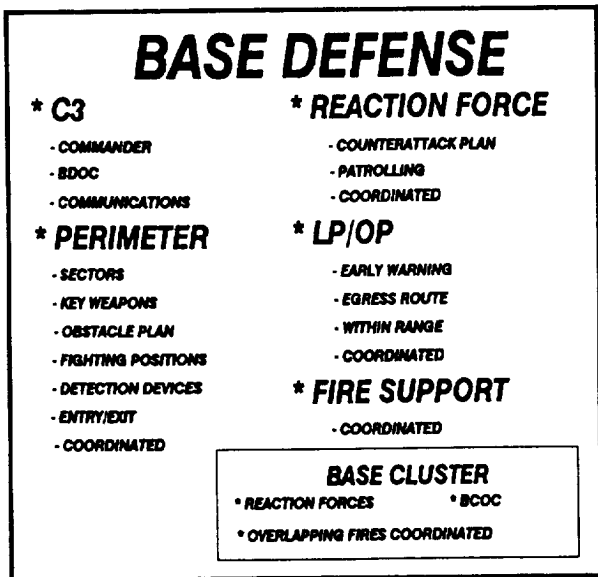

Figure 5-4. Base defense elements

Base and Base Cluster Defense. Base defense operations include all active and passive measures units take to protect themselves from enemy activity. Units conduct defensive operations concurrent with normal support operations.

These include hardening and dispersal actions, cover and concealment, deception, and immediate reaction to enemy threat or attack. Extensive use of obstacles, sensors, surveillance devices, and OPs enhances these operations.

Base and base cluster commanders must identify shortages in materiel or weaknesses in their defenses. Protective obstacles (wire, demolitions, and mines) are essential to each base's defense. Repositioning should be considered when a unit's defensive posture is inadequate to defend itself. The rear CP coordinates the relocation of a unit with its parent unit. Military police may assist in movement of critical units.

Base defenses should not automatically engage hostile forces. The first line of defense is to avoid detection. Base and base cluster commanders should implement counterreconnaissance actions in coordination with those established by the rear CP. Surveillance of NAIs, routine patrolling, and use of OPs support these actions. Base commanders should prepare to defend the base, report the hostile force, and observe it. They must understand when and if the enemy should be engaged, and when to do it. They must inform the base cluster or rear CP if they engage the threat.

The base commander establishes a base defense operations center (BDOC) in support of the tactical chain of command. The base commander, when possible, should be a battalion commander with a battalion staff. The battalion staff can plan and control base defenses and battalion operations. The BDOC plans, coordinates, and supervises base defense operations. Personnel from the base commander's unit normally form the BDOC. However, the base commander may draw personnel and equipment from his own unit and tenant units to form a functional BDOC. The BDOC may be a relatively small element, possibly as small as two personnel per shift (an NCO and a clerk/radio operator). The BDOC—

- Defines the base perimeter and establishes responsibilities for sectors.
- Ensures communications are established and maintained within the base and key locations such as entry and exit points, OPs, and the BCOC.
- Increases or decreases defensive postures based on threat condition (THREATCON).

- Develops and monitors the base defense plan.
- Monitors and reports the base defense status.
- Coordinates fire support, obstacles, reaction force, and response force plans for the base.
- Maintains a current situation map of base units, OPs, patrols, and other friendly and enemy data as required.

Base clusters rely on mutual support between bases to enhance security. Mutual support comes from the use of reaction forces to assist threatened bases, from the integration of MP patrol and surveillance plans, or from coordinated and interlocking fires if the bases are in close proximity. It is important to note there are no fire support personnel on a base cluster commander's staff. Requests for fires are processed through the division rear CP.

Base cluster commanders, like base commanders, must exercise positive clearance prior to initiating fire missions in the DRA. Positive clearance in this situation means asking the right questions of the unit requesting fire, Can you actually see and positively identify the target as enemy? Is the target doing anything hostile that requires fire now, rather than maneuver action a little later? As a general rule, the rear FSE should require "eyes on target" prior to initiating fires in the DRA.

The base cluster commander coordinates base defense force operations and conducts security operations by using the reaction forces of each base in the cluster if response forces are unavailable, Base commanders must have a plan to reestablish their reaction force if the primary reaction force is committed.

Each base cluster commander forms a BCOG to monitor the status of subordinate bases and to receive and pass information from the rear CP, The base cluster commander should be a battalion or higher commander with a staff that can accomplish unit and base cluster functions. BCOG tasks include—

- Defining the base cluster perimeter and establishing responsibilities for sectors.
- Developing and monitoring the base cluster defense plan.

- Establishing and maintaining communications with all assigned bases, separate units in the base cluster, and the rear CP.
- Receiving and passing on threat and base defense status reports.
- Adjusting defense posture based on the threat.
- Coordinating fire support, obstacle, reaction force, and response force plans.
- Maintaining a current situation map.

Response Forces

Response forces (Figure 5-5) are normally made up of MP units weighted by fire support assets. Fire support for MP response forces may consist of artillery or army aviation. Military police are trained in calling for and adjusting indirect fires. They can control CAS with assistance from a TACP or Army aviators trained in JAAT operations.

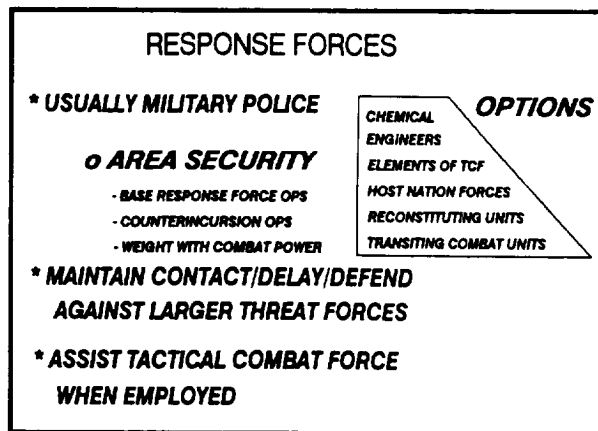

Figure 5-5. Response forces

Military police elements may be committed to other priority missions or be unavailable for commitment in sufficient strength for response force operations. In this event, back-up or alternative response forces may be formed from base CSS units; engineer, chemical, or transiting combat units; and elements of the reserve (or host nation assets, if available). The rear CP will coordinate with the division G3 prior to committing other than MPs to response force missions. Under certain circumstances, committing the TCF may be preferable. It avoids risking degradation or destruction of critical CS assets.

Planning and Coordination. Execution of response force operations requires extensive planning and coordination prior to its commitment against an enemy. Success depends on the response force knowing and properly using terrain to gain advantage over the enemy. It also depends on massing sufficient combat power to destroy the enemy.

Whenever possible, response forces should be designated for specific bases or base clusters instead of one response force for the entire DRA. This reduces reaction time for the response force, and facilitates coordination between the response force commander and base or base cluster commanders. With fewer units, the response force can concentrate its preparation in a smaller geographic area.

In addition to knowing the location of bases in his AO, the response force commander must know which bases are most critical and most vulnerable. The response force commander should have the following information available for each base and base cluster in his AO:

Ž Defensive capability.

- Base defense status.
- Location of any obstacles near the base.
- Location and direction of the of crew-served weapons.
- Signal for final protective fires.

Ž Location of target reference points (TRPs) and preplanned fires.

Ž Method of contacting the BDOC or BCOC, including call signs and frequencies.

Ž Location of OPs and patrols, if employed,

Additionally, the response force commander must be able to mass supporting fires and facilitate TCF operations, if committed. Therefore, he must know the call signs and frequencies for supporting artillery, Army aviation units, the TCF, and the rear CP. He must also know the approved DRA fire support target list.

Response Force Operations. The purpose of response force operations is to hasten a base's ability to return to mission accomplishment as quickly as possible. This avoids devoting sustainment resources to self-defense or limited tactical

operations. Response forces must commit rapidly to force an enemy to disengage from an attack before he causes significant damage to a base or bases. Once the enemy has abandoned his attack, the response force should fix and destroy him with fire support or in close combat.

Ideally, response forces will engage identified enemy elements through reconnaissance, surveillance, and counterreconnaissance actions before they attack bases. If response forces cannot mass sufficient combat power to destroy or deter an enemy, they should delay and disrupt him using fire support until additional response forces or a TCF is available.

When the response force is committed, the response force commander normally has OPCON of an AO. The base cluster commander and rear CP should develop on-order graphics to implement when a response force or TCF is committed. Base commanders support the efforts of the response force by lifting or shifting base defense fires to support the response force's maneuver. If a TCF is subsequently committed, the TCF commander will have OPCON of all bases and response forces within the TCF's designated AO.

Response forces are only effective if they can react swiftly. They must be familiar with the locations and dispositions of bases in the threatened area. Military police squads are typically assigned AOs that include bases. These units are responsible for executing MP missions within their assigned areas. This includes coordinating base defense response force operations with the bases in their AOs. Military police platoon leaders and company commanders normally coordinate with BCOCs to ensure unity of effort. When threats materialize, the rear CP conducts an assessment and, if appropriate, commits additional response force assets. If the threat exceeds the capability of response forces, a TCF may be committed. Response forces maintain contact with threatening forces and render spot reports to the rear CP and TCF commander until the TCF arrives to engage the threat.

Tactical Combat Force

The primary mission of a TCF is to defeat those enemy forces in the DRA that exceed the capability of response forces. To counter the wide variety of possible threats to the rear area, a TCF

must be flexible, capable of either day or night operations, and able to obtain an advantage in mobility. It does this either by positioning or speed of movement.

The division TCF is normally a task-organized combined arms force comprising ground or air maneuver units, FSEs, and a headquarters capable of planning and coordinating tactical operations (however the TCF is designed based on METT-T). Light infantry, augmented with attack and assault helicopters, may conduct TCF operations against similarly equipped enemy forces. Light infantry must be augmented with armor and attack helicopters if committed against armored forces. If drawn from the aviation brigade, the TCF should be an attack helicopter battalion (AHB).

The DRA IPB and METT-T analysis help determine the size and composition of the TCF. Under the division commander's guidance, the G3 designates or dedicates one or more forces as TCFs to provide flexible responses to competing needs. A TCF may be designated with an on-order mission or task-organized under the rear command. It should be organized under the rear CP when the commander determines the threat to his rear area is sufficient to justify the employment of combat forces of battalion size or larger.

A designated TCF is not committed to rear operations. It has a "be prepared" mission to respond to threats. Once committed to rear operations, a designated TCF is OPCON to the rear operations commander until the enemy is defeated. It is then released to parent unit control.

Planning and Coordination The rear CP plans, coordinates, and controls TCF operations. The DRA defense plan incorporates base and base cluster self-defense measures, response force operations, and TCF operations. The rear CP provides copies of the DRA defense plan, including fire support and obstacle plans, to the TCF. The TCF coordinates possible response plans with the rear CP, response force commanders, and base and base cluster commanders. The TCF positions liaison officers with the rear CP to help with contingency planning and employment of the TCF.

Operations. The rear CP is the C² headquarters for the TCF once committed. When the

rear CP has task-organized TCFs, it positions them in assembly areas based on requirements of METT-T.

The rear CP develops security plans to deal with rear area threats, and coordinates these plans among bases and base clusters, response forces, the TCF, and FSEs. It also supervises and controls security operations in the DRA. When a large enemy force is detected moving to or in the rear, the rear operations commander requests that the G3 place the TCF under his OPCON.

If the TCF is a dedicated force, the rear CP notifies the TCF commander of the nature, location, and perceived enemy intentions and directs the TCF to close with and destroy the enemy. The rear operations cell designates an AO for the TCF. All base defense and response forces within the AO are OPCON to the TCF commander, ensuring unity of command.

When a threat in the DRA exceeds the division's capability to defeat it, the division must request assistance from corps. The corps TCF, or a portion of the corps TCF, can be either OPCON to the division or remain under corps control, based on tactical needs. The corps TCF reverts to parent unit control on mission completion, and response forces resume normal security operations.

Area Damage Control

Area damage control consists of measures taken before, during, and after hostile action or natural disasters to reduce the probability of damage and minimize its effects. Area damage control within the rear area affects all rear operations. The division rear operations commander is responsible for area damage control within the DRA.

The area damage control process includes continuous planning and action to minimize damage and a systematic approach to resolving the impact of damage on operations. Damage control teams must accurately assess damage to determine its extent and impact on operations. Alternatives and priorities must be set for repairs to damaged facilities or materiel. Damage control plans consider rescue, firefighting, life saving, and communication.

Continual area damage control planning, including specific responsibilities and the identification of available resources, ensures continuity of rear operations. Every echelon conducts area damage control planning.

Base commanders identify available resources within their bases and assess their capability to conduct area damage control operations. The continual upgrading of base defenses includes measures to reduce the effects of damages sustained. Detailed area damage control planning is an important part of the base defense plan.

Each BCOC compiles area damage control capabilities from each subordinate base and develops a comprehensive damage control plan which it forwards to the rear CP. The base cluster plan identifies available resources within each base to direct assistance from one base to another as required.

The rear CP reviews each base cluster area damage control capability. It maintains a status of the damage control posture of each independent base and base cluster. The rear CP coordinates directly with MP, engineers, chemical, and medical treatment facilities to ensure compatibility with subordinate plans. The rear CP ensures each base's capabilities are clear and that all available resources have been identified, including host nation assets.

Planning Considerations

Military Police. Military police provide local support, including battlefield circulation control and area security. They notify the rear CP of blocked LOCs and divert traffic as necessary to ensure maintenance of forward support. They ensure evacuation routes do not become cluttered. When possible, host nation assets conduct crowd control during area damage control operations to free up limited MP support.

Engineers. Engineer support includes constructing fortifications and obstacles which reduce the impact of damages, Engineers also clear debris and rubble, to include MSR maintenance. Commanders should exercise caution in committing engineer assets to every incident. Engineers fulfill critical mobility, survivability, and countermobility missions. Division light engineers normally require external support from

nondivisional engineers to perform area damage control missions.

Medical Units. Medical units accept casualties from units near their locations. All units must know the exact location of medical facilities nearest to them so that injured personnel can receive prompt treatment.

G5 or Civil Affairs. G5 or civil affairs elements identify host nation support, especially engineer assets, to augment resources. They coordinate civilian involvement with area damage control operations.

Chemical. Chemical units support area damage control operations through decontamination of personnel, equipment, supplies, key sites, and LOCs. Survey teams from the division chemical company assist units on a priority basis as directed by the rear CP.

Explosive Ordnance Disposal. The presence of unexploded ordnance and the possibility of detonation can pose a threat to operations. Explosive ordnance disposal (EOD) operations deal with unexploded ordnance.

Explosive ordnance reconnaissance agents in each unit assist in reducing hazards and reporting unexploded ordnance to the rear CP. The agents should be trained by EOD units to assist local commanders. They should include all military police and at least two soldiers from each company-sized unit.

Aviation. Aviation assets may assist in transporting casualties. Utility helicopters can provide emergency resupply, communication relay, and aerial assessment of damages.

Operations

Once an event causes or has caused damage, specialized personnel must simultaneously--

Ž Treat and evacuate casualties.

- Control damage.
- Identify and mark unexploded ordnance.
- Secure critical assets.
- Reestablish operations.
- Conduct a damage assessment.

- Report assessment of damages and status of operations.

The rear CP evaluates the information received and, if necessary, directs further assessment of damage by aerial observation, by MP patrol, or by either its own experts or those from the DISCOM.

In developing alternatives, the rear CP or DISCOM must determine the following:

Ž What has been damaged (facilities, supplies, and equipment)?

- How extensive is the damage?
- Will engineer assets be needed for repairs?

Ž Can the unit continue its mission without major repairs?

Ž Can the unit relocate and still perform its mission?

Ž Are other facilities, supplies, and equipment available in sufficient quantity to accomplish the mission?

The rear operations cell develops damage assessments and alternatives for repair or support. Based on its evaluation, the rear operations cell develops recommendations for the rear operations commander. He then directs actions to repair damages or pursue alternatives. Other important considerations include:

- Are remaining supplies, facilities, equipment, or personnel now critical to operations? Is additional security needed?
- What is the impact on future operations, considering the losses sustained?

Ž Is it necessary to reposition units to bolster sustainment?

Division Rear Area Defense Plan

A sample base, base cluster, or rear area defense plan is at Figure 5-6. It contains the minimum essential elements which should be found in any defense plan. Division SOPs should expand on them as needed.

THE BASE, BASE CLUSTER, OR REAR AREA DEFENSE PLAN

Copy No. ___ of ___ Copies

Base ___
 Place of Issue (may be in code)
 Date-time Group of Issue
 Message Reference Number.

References: (Maps, charts, and relevant documents.)
 Time Zone Used Throughout the Order:
 Task Organization: (List all units within the base beginning with base commanders.)

1. SITUATION. (The following points will normally be covered.)

a. Enemy Forces.

(1) (List brief summary of enemy capabilities.)
 (2) (List brief summary of known activities in the area.)
 (3) (List current PIR for the rear area.)
 (4) (List criminal intelligence.)
 (5) (List information from host nation authorities concerning indigenous opposition.)

Figure 5-6. Defense plan

b. Friendly Forces.

- (1) Base Cluster____(Show designation if part of a base cluster.)
- (2) Response Force: (That unit assigned the mission of responding to threats in the area.)
- (3) Tactical Combat Force: (List unit responsible for TCF mission.)
- (4) Adjacent Bases/Facilities: (List any bases or facilities that are in close proximity and their locations.)
- (5) Reaction Force: (Show any reaction forces that may be designated within the base cluster and their locations. If none, so state.)
- (6) Host Nation: (List any units, critical facilities, activities, or authorities located near the base.)

2. MISSION. (Clear concise statement of base defense mission.)

3. EXECUTION.

a. Concept of the Operation.

- (1) Base Location: (Describe local area to include terrain features, road network, and trafficability.)
- (2) Preparation of Defenses: (List, in priority, those tasks needed to be accomplished and responsibilities for their accomplishment.)
- (3) Responses to Enemy Activity: (List base defense responsibilities, to include the percentage of response force provided by each unit and actions in response to enemy activity.)
- (4) Area Damage Control: (List responsibilities and actions in response to damages sustained by enemy actions or natural causes.)

b. Coordinating Instructions.

- (1) Base Reaction Force: (Procedures for assembling and deployment.)
- (2) Base Cluster Reaction Force: (Procedures for lifting and shifting fires in support of reaction force, rally points, and external coordination.)
- (3) Base Defense Response Forces: (Procedures for requesting response forces, location of rally points, procedures for lifting and shifting fires in support of response forces.)
- (4) Tactical Combat Force: (Procedures for supporting TCF.)
- (5) Host Nation Support: (Procedures for supporting host nation units.)

4. SERVICE SUPPORT. (Clear statement concerning available support and need to cross level support within the base. Locations of nearest class III, V, IX along with priorities of issue. HSS to include evacuation procedures.)

Figure 5-6. Defense plan (continued)

5. COMMAND AND SIGNAL.**a. Command.**

- (1) Base Commander _____.
- (2) Alternate Base Commander _____. (Designated in case base commander's unit moves out.)
- (3) BDOC located at _____.
- (4) BCOC located at _____.
- (5) (Include locations of rear CP/ROCs.)

b. Signal.

- (1) Current SOI is in effect.
- (2) (List responsibilities for establishment of communications within the base.)
- (3) (List reporting requirements to base cluster/ROC/rear CP.)
- (4) (List frequencies and call signs for reaction forces, response force, tactical combat force, and fire support net.)

Signature (Base Commander)

Annexes**A--Base Defense Sketch**

Figure 5-6. Defense plan (continued)

DEEP OPERATIONS

Division deep operations comprise tactical activities directed against enemy forces not in contact. The division commander must envision the battlefield in terms of depth and time. He does so by reviewing the corps commander's intent and concept of how the corps battle will be fought. The corps commander envisions a series of smaller battles where subordinate divisions defeat and destroy the enemy in piecemeal operations. The commander articulates this vision as an implicit contract with division commanders as to what must be done, a concept of time or events, and how the corps creates favorable battlefield conditions for divisions to defeat enemy forces. He sees a series of division battles by time or event windows, locations in depth, combat power ratios, and specific desired results.

Deep operations are used to influence the enemy so that divisions can accomplish the piecemeal destruction of enemy forces. The

division commander also envisions the battlefield in terms of depth and time to develop a series of piecemeal engagements for his brigades. He develops a deep operations plan to create favorable conditions. Deep operations will normally impact enclose operations. (See synchronization matrix, Figure 5-7, page 5-16.) To ensure an effective system, deep operations are planned, controlled, and synchronized by the commander and the G3. The G3 is the primary staff officer responsible for deep operations. Fire support and intelligence BOS are tasked for targeting and execution,

Destruction of enemy forces in the deep operation is not always the intent and is difficult to achieve because it requires massive resources. Lethality of improved conventional munitions in an air superiority environment, however, may make destruction possible. Limiting enemy movements is an asset-intensive goal requiring significant reinforced terrain obstacles. Therefore, disruption is probably the realistic goal.

DEEP ATTACK SYNCHRONIZATION PLANNING MATRIX

		F-36 to F-12	F-12 to F-10	F-10 to F-8	F-8 to F-4	F-4 to F-2	F-2 to F-1	F-1 to F+1	
DIVISION	INTEL	Request DF of ADA nets Jam at F-Hour TVA: HVT/HPT Select TAIN/AJ based on Cdr's Intent Request ADO collection assets from division and theater MI Bde (SLAR, GUARDRAIL, QUICKLOOK, MOHAWK) Request info from LRSB	Follow-up Request Collect info on mvt Follow up requests and results	Request info from MI Bn DST finalized	➔	Analyze info	➔	MISSION	
	BRIGADE	ATKHB preps for ops AHB preps for ops			➔	AHB ready for ops F-4: 2 OH58D OPCON to ATKHB	ATKHB ready for operations AHB conducts deception Go/No Go Brief		
	DIVISION	SPT	Targeting Cell meets Preplan SEAD Request preplanned AJ, deep CAS into EA, request RECCE Develop A2C2	Develop HPTs based on cdr's intent Finalize tgt list Ensure EAs are finalized Link to ACA	Detailed FB planning SEAD, EA, CAS, FSCM (RFA, RPL) Request priority of fire & Q-37 for Avn Bde Follow-up on Air Request	F-8: No more preplan tgts accepted Update tgt list and control measures SEAD Plan completed	Fire general SEAD program of battlefield		Priority of fire to Avn Bde Fire SEAD for AA Q-37 orients on EA for deep atk Go/No Go Brief
	BRIGADE	ADA							Go to Wpns Hold
BRIGADE	C2	Avn TAC preps to collocate with DMAIN	Avn TAC collocates with DMAIN		Avn TAC ready for ops		Go/No Go Brief	EXECUTION	
	CSS	Select fuel sites for FARP		FARPs move fwd		FARP 1 is operational	FARP 2 is operational		
DIVISION	DECEP	Plan AA with AHB					AHB begins air movement	MISSION	
	DECP					Has the enemy been found? Adjust EAs?	Are tgts at NAIs confirmed at F-2? Send OH58D to find enemy?		
ABVDNE		Div puts control measures for deep battle	Finalize OPORD	WO to AHB, prepare to OPCON OH58D	FRAGO to AHB OPCON 2 OH58D to ATKHB	Send out OH58Ds	FRAGO to ATKHB		
KAEY		Prepare OPORD, coordinate assets	Coord w/ Div Staff and ACA	Coord assets for deception Coord w/ Div FSE	Review tgts & FSCM	Collection of Intel	Go/No Go Brief		

F-Hour = Cross-FLOT time

Figure 5-7. Example synchronization matrix

DEEP ATTACK MISSION EXECUTION MATRIX

	F-1 to F-0:15	F-0.15 to F-HR	F-HR to F+0:15	F+0:15 to F+0:40	F+0:40 to F+1
I N T E L	Receiving timely data from OH58D; Pass to ATKHB	→		CH777 provides BDA	Send BDA to higher
	Final SPOTREP prior to crossing FLOT	QUICKFIX jamming			→
	Update enemy location	→			
M A N E U V E R	ATKHB moves to atk pos and passage points AHB executes deception	ATKHB crossing FLOT	ATKHB arrive at IP	ATKHB engages tgt, then breaks contact and egress back to FLOT AHB ceases deception ops	ATKHB to FARP AHB to FARP
F I R E S P T	Execution matrix initiated Final coord Activate A2C2 plan	Execute ingress SEAD FBCM go into effect AI into EA	Execute egress SEAD	Deep CAB OH58D calls fire on remaining tgt Execute egress SEAD	→
A D A	Weapons Hold	→			
C 2	Division Main CP				→
C S S					
D E C E P	AHB executes and controls deception plan				→
D E C I S I O N	Is there a clear picture of the enemy location? Did the OH58D go forward? What did they see? Use OH58D to lead ATKHB to EA?		Does tgt require more observation? Commit more OH58D to observe?	Does BDA meet cdr's intent/CCIR? Reengage EAs? Do OH58D need to remain on station?	→ → →
A B V D N E	Coord FLOT crossing	→		Aircraft lost/missing recovery	
K A E C Y T	Coord Arty w/ AI Execute deception			BDA; Decision for additional attack	Prepare for another deep atk

F-Hour = Cross-FLOT time

Figure 5-7. Example synchronization matrix (continued)

Disruption reduces the enemy's correlation of forces by desynchronizing or delaying his subordinate elements. The division combat commander's intention is to create engagements where friendly brigade power ratios allow brigades to defeat enemy forces.

The commander cannot just target a unit for destruction or specify an unreasonable delay period. Deep operations include the cumulative effects of many different actions on the enemy. Tangible actions include attrition, destruction, and delay of combat formations that generally alter combat force ratios. Intangible actions alter combat power multipliers by degrading or disrupting the enemy's cohesion, synchronization, massing, sustainment, or control. Deep operations, such as AI, deception, psychological operations (PSYOP), EW, direct action special force operations, counterfire, and complementary SEAD, and maneuver within the close battle are division planned and directed. They produce effects at specific points of attack, counterattack, or defense.

Deep operations are not continuous or sustained at constant levels of effort. They are developed to achieve specific results, based on the enemy, situation, and available assets. Limited assets are scheduled to support deep (and close) operations execution—not dedicated to one specific operation or unit. Deep fires may shift to mass fires against an enemy unit in the close battle and then back to deep targets until massed fire is again needed in the close operation.

The outcome of the close operation should never totally depend on deep operation results. The effect of deep operations on combat power ratios is a key factor in determining when and where to accept or initiate decisive close battle. Favorable conditions must be achieved before risking potential critical losses in decisive close battle.

The commander develops his deep operations concept when war-gaming COAs. He determines responsibilities and control for those operations and establishes phase lines and specific targets by type. Successive phase lines provide on-order lines defining deep and close operations areas for the division and corps. Either echelon may reserve specific targets or missions as deep

operations. Examples are counterfire against specific artillery echelons or mission-capable units, or counterfire into one specific area, reserve units, and division C² facilities. Specific targets reserved by type may also be attacked anywhere on the battlefield when reserved. However, the target must be identified by means other than map reconnaissance. The decision to fire on templated locations is made by the commander during war gaming. The criteria to fire targets is based on battlefield need and urgency in terms of time. Risk is reduced when the target is under surveillance by human intelligence (HUMINT) or SIGINT sources.

Corps deep operations normally interdict the enemy operational reserves (regiment- or division-sized force), degrade C² facilities, destroy sustainment facilities and distribution assets, and destroy army rocket and tube artillery assets. The division normally attacks uncommitted forces, disrupts movement of reserves or counterattacks, destroys enemy division C² facilities and ADA systems, and conducts counterfire against direct and general support artillery opposing brigades.

Maneuver and deception are used at each echelon to create overwhelming strength at a point and delay enemy repositioning of uncommitted forces. The integration of maneuver, deception, and other deep operations to the close operation is required for success.

Deep operations are planned using the estimate of the situation as detailed in FM 101-5. The estimate of the situation process also must incorporate the targeting methodology described in this chapter. (Also see Figure 5-8 for the targeting process.)

Desired damages (destroy, suppress, or neutralize) are associated with enemy units to achieve desired results. This targeting guidance must be used to evaluate targets according to attack criteria. Direct attacks attrit enemy combat forces. Indirect attacks attrit assets, facilities, or systems which support enemy forces. This evaluation begins with the development of the high payoff target list (HPTL). The targeting team matches systems to the detection means and target effects.

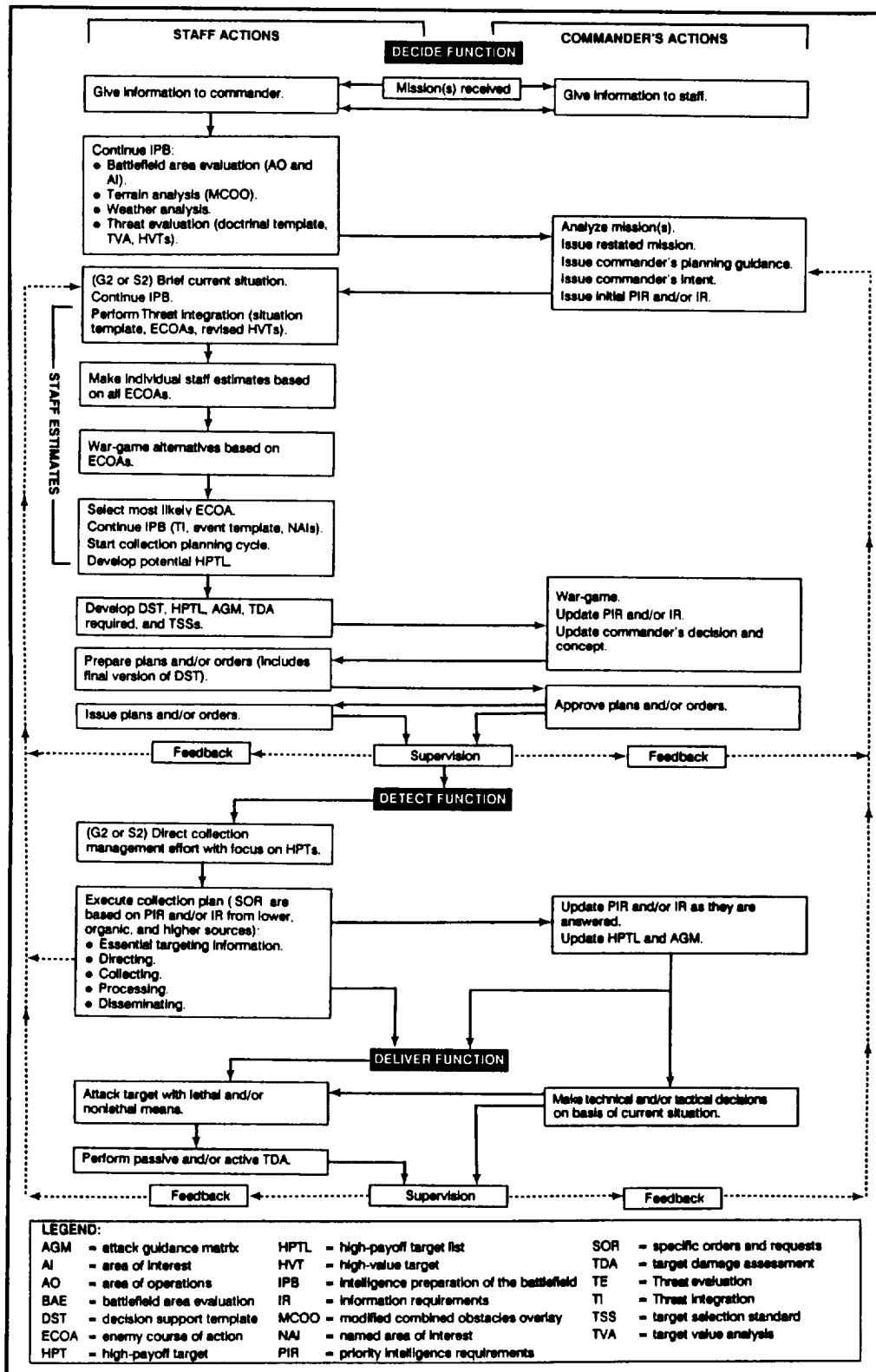

Figure 5-8. The targeting process

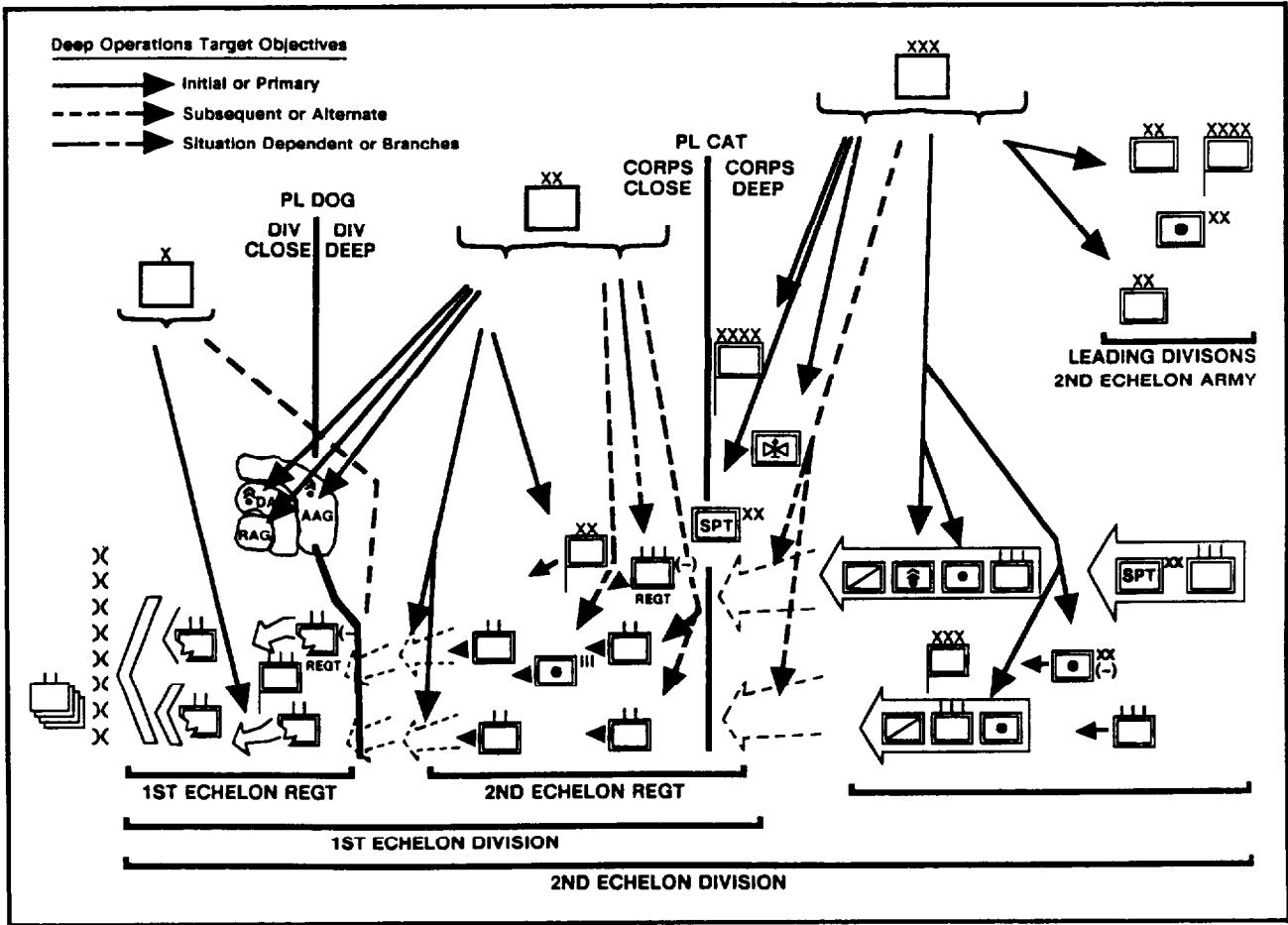

Figure 5-9. Example deep operations against an echeloned enemy force

The targeting team comprises the CofS, G3 and G2 representatives, DFSCoord, FAIO, FLO, electronic warfare officer (EWO), and G3 air. The targeting team is a full-time organization chaired by the G3. The commander is present for planning and war gaming. The others are readily available during the operation. The G3, G2, and DFSCoord are the primary full-time members for planning, war gaming, and execution. Although they may not be collocated, they function as a full-time decide, detect, and deliver targeting team. They develop the decide phase and control the execution of the detect and deliver phases by subordinate and supporting units or HQ.

The G3, G2, and DFSCoord continuously monitor the current battle, deep operations battle

damage assessment results, intelligence assessments, and sequel mission requirements. The G3 issues FRAGOs (approved by the commander), to change decide guidance or provide new guidance when required. The G2 is the principal controller for the detect phase and for its execution. The DFSCoord is the principal controller and coordinator for the technical planning and tasking of the deliver plan and for its execution. (See Figure 5-9.)

RECONNAISSANCE OPERATIONS

Reconnaissance is an essential and continuous operation which the division conducts to collect information and gain and maintain contact with the enemy. The G2 processes information into intelligence and provides combat information to the commander.

Reconnaissance should not be confused with security operations, nor should a unit have both reconnaissance and security missions at the same time. The objective of reconnaissance is to find (and acquire information about) the enemy. Security operations protect the friendly force from enemy actions and deny him information.

The G2 has staff responsibility for reconnaissance. He assigns reconnaissance tasks to subordinate units through the collection plan. He coordinates with the G3 to allocate resources and assign specific reconnaissance missions to subordinate commanders when required.

Reconnaissance of some type should always precede a commitment of forces. Time available will determine the extent of reconnaissance. Failure to conduct a thorough reconnaissance may result in loss of initiative and unacceptable losses in personnel and equipment.

Reconnaissance enables the G2 to confirm or deny enemy templates and the enemy's most probable COAs (developed during the IPB process). Reconnaissance by ground or air maneuver elements can confirm information developed by IEW assets. It can provide detail and verification that IEW assets cannot. For example, direction-finding assets may locate enemy CP transmitters. Ground or air reconnaissance elements may physically locate the CP. Similarly, reconnaissance elements in front of the covering force can assist a covering force commander to orient on specific avenues of approach.

The three types of reconnaissance (See Figure 5-10) are route, area, and zone. Route reconnaissance is conducted to obtain detailed information about a specified route or routes and surrounding terrain the enemy could use to influence movement. Area reconnaissance obtains information about a specific area such as a town or a proposed assembly area. Zone reconnaissance is a detailed, thorough, time-consuming reconnaissance of all important terrain within specified boundaries. Methods of reconnaissance include—

• Patrols.

• Reconnaissance by fire.

• Armed reconnaissance.

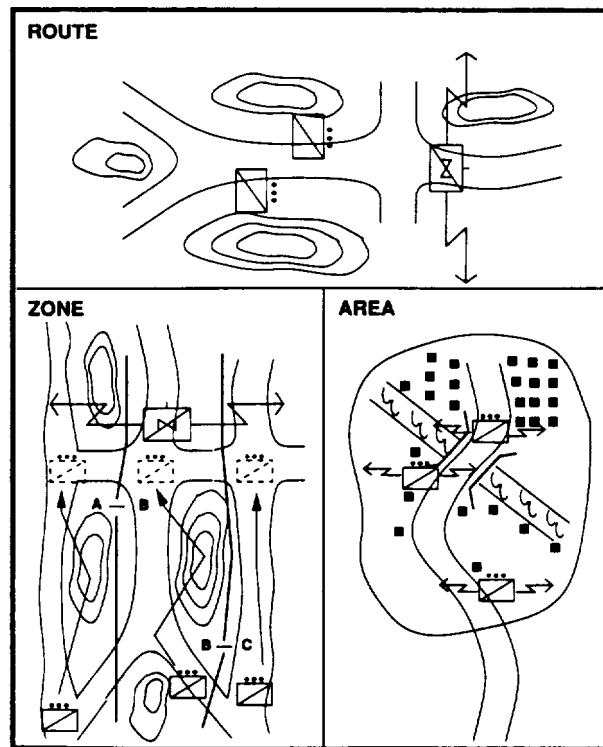

Figure 5.10. Types of reconnaissance

Reconnaissance may be aerial, ground-based, or a combination of both. Each method has its purpose and techniques. Armed reconnaissance can locate and attack targets of opportunity in its prescribed area or route. Reconnaissance by fire causes an enemy to disclose his position by movement or return fire. A reconnaissance patrol gains information about the enemy without his knowledge.

Planning

The G2 plans the division reconnaissance effort using the collection plan, which fills gaps in combat intelligence. The G2 integrates division assets into the reconnaissance effort by developing intelligence acquisition tasks to support the collection plan. He considers availability and capability of units, IEW assets, air and ground maneuver capabilities, field artillery radars, and TACAIR reconnaissance.

The G2 prioritizes the reconnaissance effort using the commander's PIR and IR. He coordinates the reconnaissance effort through assignment of intelligence acquisition tasks to units

through the intelligence annex to the division OPORD. During the execution of the division's mission, the G2 coordinates specific reconnaissance missions with the G3.

The G2 synchronizes the reconnaissance effort by sequencing reconnaissance tasks. He considers when information is required as well as the acquisition time required.

The G2 determines the reconnaissance required in the deep operation and tasks assets, or recommends their tasking to the G3. These will normally be SIGINT or IMINT sources. However, the G2 may recommend that the reconnaissance squadron or aviation brigade conduct a deep area reconnaissance.

The G2 may assign reconnaissance tasks to the security force's covering force, advance guard, or both. These reconnaissance tasks are accomplished as concurrent operations to the unit's security mission and may include route or area reconnaissance tasks.

In the close operation or MBA, the G2 may assign reconnaissance tasks to committed forces. These tasks are collateral to the unit's assigned mission. Tasks may include reconnaissance of defensive positions or lateral routes. The G2 may recommend that the G3 assign units to reconnaissance in force, reconnaissance by fire, or armed reconnaissance. These missions may refine intelligence collected by IEW sensors or complete more detailed reconnaissance. For example, the air troops of the reconnaissance squadron might report heavy ground fire along a route they were reconnoitering as part of an offensive covering force. The G2 may recommend an advance guard to conduct a reconnaissance in force of the suspect area.

The G2 may assign reconnaissance tasks in the reserve area to the reserve brigade, MPs, or engineers. These reconnaissance tasks may include route reconnaissance of counterattack routes or reconnaissance of likely pickup zones (PZs) or LZs.

In the division rear, the G2 may assign reconnaissance tasks to CS or CSS units. Tasks may include patrols of likely PZs or LZs, reconnaissance of reconstitution sites, or route

reconnaissance to support the movement of another unit across the division rear.

The G2, in coordination with the G3, resources the reconnaissance effort. On the basis of intelligence gaps, the collection plan, assets available, and sequencing, the G2 recommends task organization of IEW assets to support the division reconnaissance effort and those of subordinate commands. When required, the G2 may recommend assigning reconnaissance missions to subordinate commands.

Reconnaissance tasks should be specific. Mission-type orders will not suffice. The G2 must be specific about where to look, what to look for, and what information is required. This assists the G2 and G3 in determining the resource allocation to subordinate commanders. It also provides specific tasks to subordinate commanders for their own mission planning.

The G2 must ensure that the plan does not spread available reconnaissance assets too thin. It is not wise to disperse reconnaissance elements across wide frontages to accomplish multiple tasks simultaneously. The capabilities of IEW assets and moving target locating radars should be part of the reconnaissance effort. These can focus the reconnaissance of ground or air maneuver elements.

Reconnaissance should include specialists such as engineers and chemical personnel. The division reconnaissance squadron and battalion scouts are not the only organizations that conduct reconnaissance.

The G2 should assign reporting schedules to the assets conducting the reconnaissance. This allows him to monitor the progress of the reconnaissance and redirect efforts as required.

Routine reports should pass through the division intelligence or operations and intelligence nets. Critical information should be submitted using the division command net. This combat information, although unevaluated, may have immediate tactical significance to the commander.

In offensive operations, the commander should base his plan for maneuver on the concept of "reconnaissance-pull." Reconnaissance

determines which routes are suitable for maneuver, where the enemy is strong and weak, and where gaps exist. Thus, reconnaissance should pull the main body towards and along the path of least resistance. This facilitates the division's initiative and agility.

Reconnaissance-pull is also valid in defensive operations. Reconnaissance determines which routes the enemy is using, where the enemy is strong and weak, and where gaps exist. Thus, reconnaissance enhances agility by identifying opportunities and pulling the division along the path of least resistance to mass the division's combat power at the critical time and place.

Techniques

Reconnaissance missions inherently place units in harm's way. Stealth cannot be ensured and is at best circumstantial. Firepower, aggressive action, and deception are required for survival and mission accomplishment.

The division should expect the unit assigned a reconnaissance mission to do more than just find the enemy. Reconnaissance operations at the divisional level should develop the situation by—

- Penetrating or disrupting the enemy's security forces.
- Ž Forcing the premature commitment of reserves.
- Ž Forcing the early uncovering of artillery,
- Ž Fighting through and uncovering enemy deception schemes.

Reconnaissance operations should develop the situation to the tactical depths of the opposing enemy formation. The reconnaissance squadron is the division's primary reconnaissance unit. Its use should prevent the decisive commitment of main force units. By locating the enemy, developing the situation, and discovering or creating weakness, the squadron should improve the division's ability to put decisive combat power at the right place at the right time.

The reconnaissance mission should also be closely integrated with the other division intelligence collection assets for a cohesive battle picture. When possible, the reconnaissance squadron should be tied into the LRSD and combat radio nets of the intelligence and electronic warfare support element (IEWSE).

SECURITY OPERATIONS

The division conducts security operations to provide maneuver space and reaction time, and protect the main body. It incorporates security as part of the battlefield framework in planning all offensive or defensive operations.

The G3 develops and recommends the concept of operations. This includes assigning security responsibilities and missions to subordinate commanders, who then plan, prepare, and execute security operations. Every unit has a continuous security role.

Types of Operations

Security operations include screen, guard, cover, and counterreconnaissance operations. Screens maintain surveillance, conduct counterreconnaissance, provide early warning to the main body, and harass and impede the enemy through indirect fires. Guard missions include the functions of screen and protect the main body from ground observation and direct fire. Cover includes the functions of screen and guard operations but also develops the situation. Cover deceives, disorganizes, and destroys enemy forces.

Counterreconnaissance is inherent in *all* combat operations. It prevents the enemy from obtaining information about the division through visual observation or other detection means.

Planning Considerations

As the G3 and other staff members incorporate security requirements into the planning of division operations, they should consider—

- Adequate support to security forces.
- Ž Ranges and capabilities of IEW, fire support, and communications systems.
- Time-distance relationships.
- Economy of force factors.
- Passage of lines.
- Ž Formation of the main body.

The covering force, especially in offensive operations, operates well forward of the division main body. The G3 allocates resources to the covering force so that it functions as a tactically self-sufficient force.

Guard forces operate within supporting range of the main body. However, the G3 and other staff elements must consider relationships between the main body and the guard force.

The staff must consider the range and capabilities of combat and CS weapons and systems as it assigns security responsibilities and missions to subordinate commanders. While some cannon artillery may range to 30 kilometers with rocket-assisted projectile (RAP) ammunition, the amount of RAP ammunition and its capabilities are less than dual-purpose improved conventional munitions (DPICMs). Similarly, IEW assets may range to 30 kilometers; however, terrain, weather, and enemy ECCM actions may significantly reduce the range.

The staff should consider time-distance relationships when using screens or guards. Screens provide early warning to the main body. Planning must consider the time required for the main body to counter a threat and compute the distance the enemy could move during that time. This aids in determining location of the screen. If sufficient maneuver space is not available to accommodate this time-distance relationship, then the staff should consider employing a guard rather than a screen.

Planners should consider economy of force in assigning security responsibilities and missions. Fewer forces are required to screen a force than to guard it. Where possible, the plans element should consider employing screens as opposed to guards. The considerations of adequate support, time-distance, and the threat will affect this decision.

Planners should consider the requirements for passage of lines by security forces. An offensive covering force may be required to conduct a forward passage as it begins a movement to contact, or leads the division in an exploitation or pursuit. Similarly, a defensive covering force may execute a rearward passage into the MBA. Screens or guards may conduct a passage with main body forces. This consideration may assist the G3 in determining which headquarters provides and controls the security force. A brigade passing through an advance guard which it controls is easier to coordinate than one passing through a division-controlled advance guard.

The staff must also consider the division formation. Each formation has its own strengths, weaknesses, and planning considerations for security.

Offensive Covering Forces

Cover missions differ between offensive and defensive operations. A division offensive covering force may be a brigade reconnaissance in force. The division commander establishes objectives to support his scheme of maneuver based on the IPB and available intelligence about the enemy.

A covering force orients on objectives established by the G3 and division commander. These objectives may be in the enemy's security zone with a counterreconnaissance orientation to strip the enemy's ability to determine in what force, and where, the division is attacking. This requires the covering force to use a two-team method. One team locates the enemy reconnaissance in the security zone and another team destroys it.

Locating enemy reconnaissance normally requires a mix of ground, aerial, and electronic reconnaissance to confirm the situational templating of enemy security zone forces. Ground forces may include battalion scouts, COLTs, and LRS teams. Their mission is to locate enemy forces so that other maneuver and fire support assets may attack them. During this phase of the covering force operation, enemy reconnaissance is a high payoff target.

Another objective of a covering force may be to determine routes through enemy defensive belts. The covering force uncovers enemy strengths, weaknesses, gaps, locations, and dispositions and serves as a reconnaissance-pull for the main body. It may conduct limited objective attacks or probes across a wide front.

If the covering force successfully negotiates the first defensive belt, it continues to the second belt. If it is not successful, it establishes a hasty defense and waits to pass the main body. It maintains contact with the enemy. It coordinates the passage of the main body with the TAC CP.

If the covering force conducts a movement to contact against a moving enemy, it still operates as a reconnaissance in force. It conducts a series of

limited objective attacks. It uses the objectives to orient its movement. The battalions of the covering force seize each objective and continue until contact is established. Reconnaissance and counterreconnaissance continue to be paramount. Once it establishes contact, the covering force conducts a hasty attack or hasty defense to pass the main body.

The G2 must consider IEW support for the offensive covering force. He must allow for redundancy in IEW systems to support its rapid forward displacement. He must disseminate combat information and intelligence to the covering force. The IEWSE provided to the maneuver brigade by the MI battalion assists in this function.

The G2 must provide a full complement of multidisciplined MI resources to the covering force. To ensure effective coordination and control, they will normally be task-organized into an MI company team. Ground-based systems must be able to rapidly displace. They should operate in pairs to leapfrog between positions and maintain continuous coverage.

Aerial intelligence assets, such as Quickfix, should habitually support the offensive covering force. They can provide continuous long-range coverage over wide areas forward and to the flanks of the covering force. They may also cue other systems to confirm or deny information provided by other agencies, and to provide coverage while ground-based systems displace.

Aerial reconnaissance may include tactical air reconnaissance on the use of remotely piloted vehicles (RPVs) or aerial scouts. Voice intercept and Quickfix (when not jamming) may be used for communications intercept.

Signal intercept systems identify and collect technical data on key enemy command, control, and communications (C³), target acquisition, and fire control systems. They monitor nets for exploitable information and pass target data to maneuver units, the FSE, and jammers.

Ground support radars provide early warning, information on enemy movement, and targeting information. They provide continuous support through leapfrog movements between positions on dominant terrain.

The division may insert LRS teams along routes to observe enemy activities. Interrogators can move with and support the covering force through interrogation of noncombatants until EPWs are taken. Intelligence teams conduct hasty screening and interrogations for information of immediate tactical value. This includes information about enemy forces, obstacles, the terrain, and enemy plans and intentions.

Fire support planning must include both supporting and deceptive fires. If sufficient artillery is available, each battalion in the covering force should have a DS battalion.

Countefire radars should be part of artillery task organization. The covering force should establish critical friendly radar zones around the main effort to expedite reactive counterfire. Call for fire zones (CFFZs) should be established on suspected enemy firing locations.

Fire support coordination measures should be permissive and on order. They should be in conjunction with phase lines and well ahead of the covering force. Fire plans should be simple, but as detailed as possible. The FSE should plan groups and series of targets to support the rapidly moving maneuver forces and plan FASCAM on flank avenues of approach.

The FSE should include jamming, especially against the enemy's reconnaissance and fire support (FS) nets in the FS plan. Quickfix provides a relatively deep capability to jam enemy C² nets.

Close air support should be integrated into the FS plan, and when possible, preplanned against the enemy. Even when the enemy is moving, the G2, G3, and FSE can project when they expect to make contact with the enemy. War-gaming this event may provide an approximate location and time for preplanning CAS.

The G3 task organizes AD assets, based on the ADA battalion commander's recommendation, to the covering force from the AD battalion. These may be a mixture of Vulcan and Stinger systems. Stinger teams are positioned on dominant terrain and along likely air avenues. Because of their short range and need to match the momentum of the covering force, AD assets should be part of the subordinate units of the covering force. These teams can also be

reconnaissance assets. Each Stinger team has a vehicle, radio, and binoculars. Locating them with IEW assets assists in local protection and air defense for the IEW assets, and simplifies terrain management and movement control.

The covering force AD commander must coordinate with the AD battalion, the covering force signal officer, and the S3 to provide the covering force AD systems the capability to monitor the division AD early warning net. The covering force engineer plans mobility and counter-mobility support.

Engineers with the covering force identify routes for forward movement and lateral routes to provide the commander flexibility as he develops the situation. In coordination with the FSE, the engineer plans FASCAM on avenues of approach into the flanks of the covering force. The engineers should be prepared for earth moving, rapid obstacle breaching, and assault bridging (if required).

Defensive Covering Forces

In the defense, the corps, not the division, normally provides the covering force. This allows the corps to control the covering force battle and shape the battlefield rather than allowing each division to fight an independent battle. If required, however, the division's covering force operates well forward of the main body to develop the situation and deceive, disorganize, and destroy enemy forces. The covering force mobility is normally equal to or greater than that of the opposing force.

The defensive covering force mission may be to delay forward of a given phase line or time or event. For example, the division commander may tell the covering force commander to delay forward of a phase line for 24 hours or until the covering force is 70 percent combat-effective.

The division must plan for the rearward passage of the covering force by establishing passage points with the MBA brigades, and the battle hand-over line. A phase line depicts the area the covering force is to delay in front. It should be forward of the battle hand-over line. This gives the covering force commander the depth to complete the delay and yet retain enough maneuver space to conduct an orderly passage. This also

aids in the covering force's staggered withdrawal. Maneuver forces in the covering force should execute detailed counterreconnaissance plans. These incorporate measures discussed later in this section.

Intelligence and EW assets supporting the defensive covering force are much the same as in the offensive covering force. In the defense, IEW resources leapfrog to the rear, withdrawing in a way that facilitates their use in the MBA.

Fire support assets are organized and function in much the same manner. Fire support plans are more detailed and an integral part of the scheme of defense. Artillery and other fire support must be planned to mass at critical times and places. Observers watch obstacles and plan fires to cover them. Fire support measures are permissive and close enough to the covering force to facilitate engaging the enemy. This is especially critical as the covering force withdraws into the range of artillery in the MBA.

Close air support is planned for EAs. The LRS teams observe and monitor decision points for initiation of these attacks. Engineers with the covering force conduct countermobility and survivability tasks as their first priority.

Air defense assets provide coverage on likely air avenues of approach. This is critical as the covering force tends to mass during the withdrawal. Coverage of passage points and lanes into the MBA must be coordinated with the MBA air defense forces.

Guard Missions

The advance guard and the offensive covering force differ in their orientation during movement and in their zone of operations. The covering force focuses on the enemy, maneuvers towards him, and covers the entire division zone. The advance guard orients on the movement of the main body. It provides security along specific routes of movement of the main body.

The advance guard operates within supporting range of the main body and protects it from ground observation and direct fire. The division may provide and control the advance guard or assign a maneuver brigade this responsibility.

The G3 operations in the TAC CP monitors the advance guard's operations if it is division-controlled. The G3 monitors its advance and operations as with any other committed force. He integrates the actions of the advance guard with those of the covering force and main body.

The advance guard conducts route reconnaissance in front of the main body. The TAC CP coordinates its movement with the main body to ensure that it remains within supporting range. Phase lines control this movement and allow the advance guard to speed up or slow down, depending on the status of the main body. Generally, reconnaissance elements of the advance guard should remain within range of supporting artillery.

Artillery moves to provide support to the advance guard (as well as flank and rear guards) and to rapidly occupy positions when the main body must deploy. This gets the artillery off-road networks to allow movement of maneuver forces. Priority of fires is to the advance guard during movement. This facilitates conduct of a hasty attack or hasty defense. The FSE at the TAC CP coordinates this for the advance guard FSE when the advance guard is under division control.

The advance guard FSE plans fire support much like the covering force's, emphasizing simple fire plans with as much detail as possible. Groups, series, and smoke missions are planned to support the maneuver commander's scheme of maneuver. The FSE coordinates these through the TAC CP FSE.

The TAC CP coordinates IEW support for the division-controlled advance guard. The G2 operations at the TAC CP disseminates combat information and intelligence from the covering force and main CP to the advance guard.

Similarly, the G3 at the TAC CP coordinates engineer and AD support for the division-controlled advance guard. He coordinates with the AD battalion and the engineer battalion to provide required support.

Engineer elements in the main body respond to the advance guard requirements. Because of their short range, air defense assets move with the advance guard, leapfrogging with the maneuver force as it moves. When the lead brigade or

brigades provide the advance guard, the maneuver brigade coordinates, integrates, and supports the advance guard.

Flank Guard

The maneuver brigades of the main body normally provide and control flank guards. This mission entails the conduct of defensive operations to the flanks to prevent ground observation and direct fire against the main body.

The flank guard (see Figure 5-11) establishes defensive positions to the flanks for stationary or moving forces. To secure the moving force, the flank guard leapfrogs forces to successive positions along the flank of the main body. These focus on battalion mobility corridors. This allows the battalion conducting the flank guard to occupy two positions while one company team leapfrogs to a forward position. The antitank (AT) company of the airborne or air assault division may act as a counterattack force. The scout platoon may conduct a screen to the flank or to the front of the task force. This requires close coordination of engineer assets and fire planning by the flank guard.

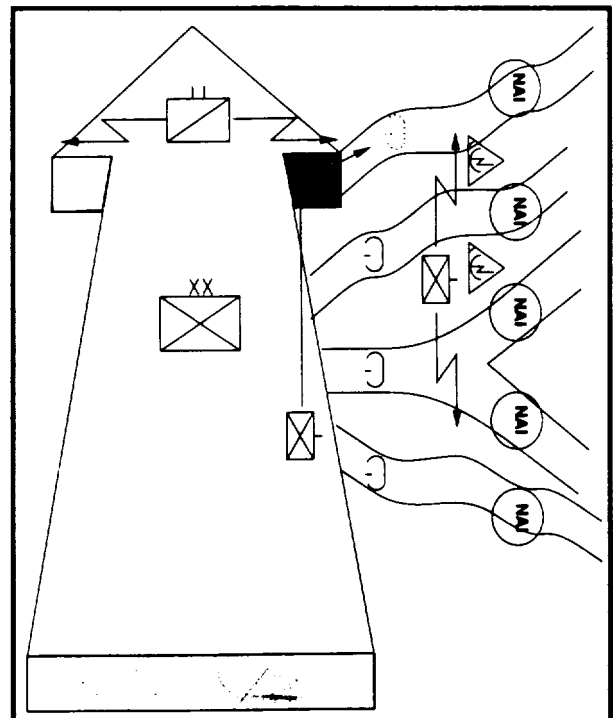

Figure 5-11. Flank guard

Similarly, the brigade S2 closely coordinates IEW support for the flank guard. The flank guard must plan R&S in detail. Intelligence and EW assets such as GSRs must be part of this plan for early warning, monitoring of threats, and economy of force. The flank guard S2 must establish NAIs and TAIs. Counter-reconnaissance actions assist in providing security to the flank guard and ultimately the main body. They may also provide the first indication a threat is developing to the flank.

The maneuver brigade controlling the flank guard should plan for its reinforcement or withdrawal. To reinforce the flank guard, it becomes the fixing force while other brigade elements engage the enemy with fire and maneuver. To withdraw the guard, the brigade establishes a hasty defense and passage points for the flank guard to withdraw into the brigade positions.

Rear Guard

The rear guard protects the main body from the rear during retrograde operations or from bypassed units during exploitation and pursuit. (See Figure 5-12.) The rear guard must orient on the movement of the main body to prevent gaps

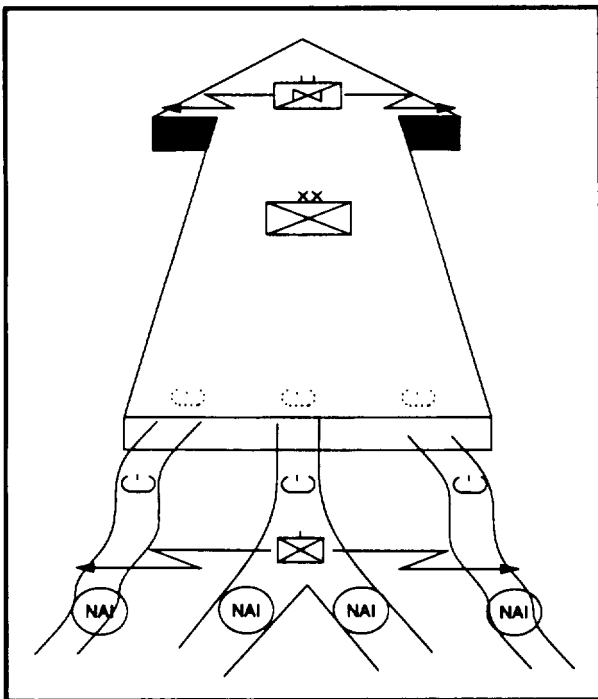

Figure 5-12. Rear guard

from developing and being cut off. Main body forces must position supporting elements toward the rear of the main body to support the rear guard. This is particularly true of artillery. During retrograde operations, the first priority of CAS should be to the rear guard.

The rear guard commander prepares to conduct a series of delays from subsequent battle positions. He must not decisively engage unless the controlling commander approves. The main body may not be in a position to reinforce the rear guard.

During offensive or retrograde operations, the rear guard occupies battle positions. It leapfrogs to new positions towards the main body. The rear guard elements closest to the enemy should not be outside supporting range of the main body. This requires close coordination between the rear guard and its controlling headquarters. The rear guard commander must closely monitor his subordinate units to allow displacing forces to occupy new positions before in-place units vacate theirs.

The rear maneuver brigade or TAC CP controls the rear guard. During the exploitation and pursuit, the rear maneuver brigade controls the rear guard. During retrograde operations, the TAC CP controls the rear guard.

Main body forces should identify and assist in preparing battle positions for the rear guard force. Engineers should prepare survivability positions. They also conduct countermobility operations to delay, disorganize, and limit the enemy force. In retrograde operations, they coordinate obstacle free zones and lanes through obstacle belts with the rear guard. Artillery, helicopter, and AF-delivered mines can rapidly close these lanes and reinforce breached obstacles. In the exploitation and pursuit, FASCAM should assist the rear guard to delay the enemy and to block approaches from the rear. Fires should be planned to assist the rear guard to disengage and move to subsequent positions.

Screen

Screens provide early warning and harass and impede the enemy with indirect fires. The division may use screens as an economy of force security mission. When sufficient maneuver space exists, the division should position the

screen far enough away from the main body to allow sufficient time to identify and counter the threat. This distance will probably be outside the range of supporting artillery. For this reason, CAS and attack helicopters should support the screen.

The screen commander combines reconnaissance, surveillance, and counterreconnaissance techniques to identify threats to the main body. He uses the IPB process to identify enemy avenues of approach and to establish NAIs for his forces to observe. As he identifies a threat, the screen commander reports to the TAC CP and uses counterreconnaissance within his capability to impede the enemy. Concurrently, he uses FS assets against the threat. This may require the screen to leave stay-behind forces to direct the attack. Scouts with attack helicopters may also direct the attack. As the screen withdraws into range, it employs main body artillery.

Counterreconnaissance

Counterreconnaissance is the sum of actions taken by all division units to counter enemy reconnaissance efforts throughout the division's AO. A detailed analysis of the enemy's reconnaissance capabilities during the IPB is crucial to understanding the nature, composition, and timing of the enemy's reconnaissance elements. The division will face different threats. For example, if the division is defending in the MBA behind a covering force, it may face reconnaissance elements not destroyed by the covering force as well as reconnaissance elements of follow-on echelons.

The G2 develops doctrinal and situational templates for reconnaissance and main body elements during the IPB process. He identifies likely avenues of approach and develops NAIs to focus the collection and monitoring assets of the division.

The division G3 uses this information to determine required counterreconnaissance actions and to task units to execute them. The G3 fixes responsibilities and provides resources to units to locate, fix, and destroy enemy reconnaissance forces. Counterreconnaissance requires a two-team approach—one to conduct surveillance and acquire enemy reconnaissance elements, another to close with and destroy them.

Counterreconnaissance consists of active and passive measures. Active measures detect, fix, and destroy enemy reconnaissance elements. Passive measures conceal friendly units and capabilities and deceive and confuse the enemy. The G3 integrates both types into the division's counterreconnaissance plan.

All subordinate units develop and coordinate their counterreconnaissance actions. They fix responsibility for patrols, ambush requirements, specific OP locations, GSR sites, and observing of NAIs. The G3 reviews subordinate unit counterreconnaissance actions and issues additional taskings to fill any gaps.

Countering the enemy's reconnaissance presents a two-part problem. First is how to acquire the reconnaissance elements. Second is how to destroy them, once acquired. The commander and staff should—

- Develop NAIs and assign responsibilities for observation.
- Provide for continuous surveillance (overcommitment of the counterreconnaissance force weakens security).
- Use aviation assets to detect infiltration.
- Assign specific responsibilities for obstacle security.
- Plan to recover forward security elements.

The central purpose of enemy reconnaissance is to gain accurate, timely, and current information about friendly forces, terrain, and weather along the enemy avenue of approach. Typical enemy reconnaissance objectives are to—

- Identify, locate, and report on friendly headquarters, nuclear-capable weapons systems, troop locations, communications centers, and movement of enemy forces.
- Determine the disposition of friendly defenses, locate friendly boundaries and artillery positions, provide terrain information on the approaches to friendly defensive positions, and report friendly emplacement of demolitions, minefield, and other obstacles.
- Determine obstacle crossing sites and provide hydrographic information on water obstacles.

- Monitor areas of suspected NBC contamination.
- Identify routes for advance, withdrawal, and lateral communications.
- Identify possible sites for communications installations.

TARGETING

The division conducts targeting to mass combat power at critical times and places. The targeting process results in integrating all means of fire support. Targeting aids the division commander in seizing the initiative and synchronizing combat power in deep, close, and rear operations. Its purpose is to disrupt, delay, or limit enemy capabilities which can interfere with division operations by destroying, neutralizing, or suppressing enemy units and systems.

Targeting is an integral part of planning, preparing, and executing division operations. It begins with receipt of the mission and continues through completion of the operation. FM 6-20-10 is the division's base manual for targeting operations.

Considerations

The targeting process supports synchronization by focusing detection and delivery capabilities on high payoff targets. The HPTs warrant expenditure of resources to ensure the division's success or subordinate commander's intent and concept of operations. Diluting the targeting effort by identifying large numbers of HPTs defeats the purpose. The greater the number and diversity of HPTs, the less likely the division can detect and engage them all. This is also true of attack guidance. The greater the number of immediate targets, the less likely the division will be able to engage them all.

A finite capability exists to detect and deliver attacks against HPTs while simultaneously conducting tactical operations. The division must balance its capability to detect HPTs with its capability to engage them. The division must also consider the effect on subordinate commanders and their plans. If detection and delivery assets are totally committed to the detection and attack of division targets, they cannot support subordinate commanders' requirements. The G2, G3, and fire support coordinator (FSCOORD) must

consider this problem. Attacking division HPTs with artillery units working for a subordinate maneuver force may desynchronize that subordinate commander's plan.

During the development of COAs and war gaming, the division plans element, which also functions as the planning cell's targeting team, must identify critical targets and critical times or events. This establishes priorities for detection and engagement.

These critical targets and times focus and integrate the intelligence effort on what is really important. This enhances and expedites the collection, processing, and dissemination of intelligence and target information. Similarly, these critical targets and times focus and synchronize fire support, maneuver, and CS assets at decisive times and places. This facilitates the allocation and prioritization of resources.

Time may be the most critical resource. The targeting process creates opportunities for the division and subordinate commanders. Utilizing the time available, they position assets to detect and engage critical enemy units and capabilities. Without this focusing effort, detection and delivery assets may be mispositioned, or they may detect and engage inappropriate targets or those of less value. Intelligence and attack assets may incorrectly focus on targets critical to the enemy but not to the division or subordinate commanders' intent and concept of operations. At best, these actions do not achieve the high payoff desired; at worst, they may have a desynchronizing effect.

Methodology

The targeting methodology is to decide the HPT, detect it, then deliver the attack. The decide portion is the planning phase of the targeting methodology. The detect and deliver portions are the execution phase. The G3 is responsible for the decide and deliver portions of this process. The G2 has staff responsibility for the detect portion. (See Figure 5-13.)

During the development of sequels to the current operation, the planning cell of the division main CP also functions as the plans' targeting team. The targeting team, under the supervision of the G3, develops the decide portion

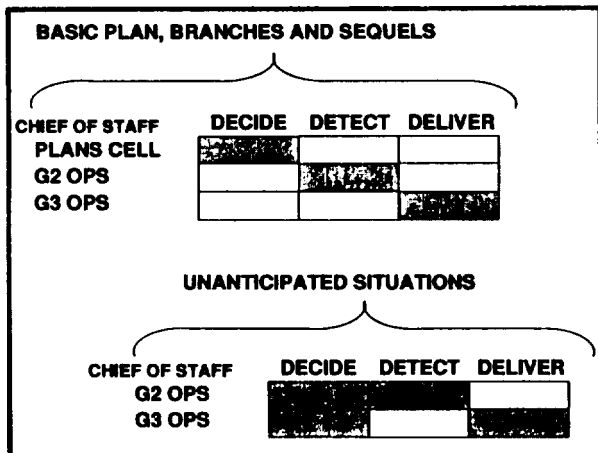

Figure 5-13. Targeting roles

of the targeting process during COA development and war gaming. (Example of a generic targeting team includes representatives from G2 and G3 plans, FSCoord, FA intelligence, G3 air, aviation brigade, EW, ALO, engineer, and NBC.)

During the execution of current operations, the targeting cell comprises the G2 operations, G3 operations, and DFSCoord. They coordinate with the TAC and rear CPs and synchronize changes to the targeting effort (detect, deliver) as it is executed.

A targeting board meeting (team and cell members) is held periodically to validate the current HPTL and attack guidance based on current METT-T analysis and future plans. A standardized targeting board agenda (Figure 5-14) is followed to focus team members on events that may affect the current HPTL and attack guidance. A technique for validating the current HPTL and attack guidance is for the G3 to brief future operations in blocks of time (for example, H+12 to H+24, H+25 to H+37). The team then validates the current HPTL against each time block. Based on its analysis of each time block and its synchronization with future operations, the team recommends necessary changes to the HPTL and attack guidance for approval by the division commander or his designated approving representative (for example, CofS). This same process occurs during each scheduled targeting board meeting. The targeting process is dynamic, requiring constant validations and updating.

Similarly, when the targeting cell discovers an unanticipated opportunity or threat that affects the current operation, it develops, coordinates, and synchronizes the division's FRAGO to incorporate this change in the situation. During the development of the FRAGO, the cell uses the targeting methodology to determine any changes

TARGETING BOARD BRIEFING SEQUENCE	
G2	– Enemy situation (current and anticipated), ADA current overlay of enemy defense units, known/suspected HVTs
G3 Operations	– Current friendly situation
G3 Plans	– Future plans (by time blocks) – Fire support needs, proposed HPTL
G2	– Collection assets available (organic and EAD) – Taskings requirement—current and future
Deputy FSCoord	– Fire support coordination measures – New/proposed targets – Corps target nomination – Recap of targeting changes (proposed future HPTL) and recommendations
CofS	– Approves/recommends changes to division commander (if required)
G3	– Actions required as a result of meeting (FRAGOs, future plans)

Figure 5-14. Example targeting board agenda

in targeting. It coordinates any recommended changes with the TAC and rear CPs.

Decide

The decide phase of the targeting process develops a HPTL, target selection standards, and attack guidance. The targeting team in the division main CP conducts this portion of the targeting effort during COA development and war gaming of the division OPORD for the sequel to the current operation. The targeting team presents its recommendations to the CofS, G2, G3, and FSCOORD for review prior to the division commander's approval.

The intelligence plans officer conducts the first step in the decide phase. Using target value analysis, he identifies high value targets (HVTs), to include units or capabilities critical to the success of the enemy's most probable COA.

Using this set of HVTs and the friendly COAs, the targeting team determines which of the HVTs to engage to ensure success of the friendly plan. These are normally expressed as target sets such as maneuver; fire support; reconnaissance, surveillance, and target acquisition (RSTA); air defense; or other categories as shown in Figure 5-15.

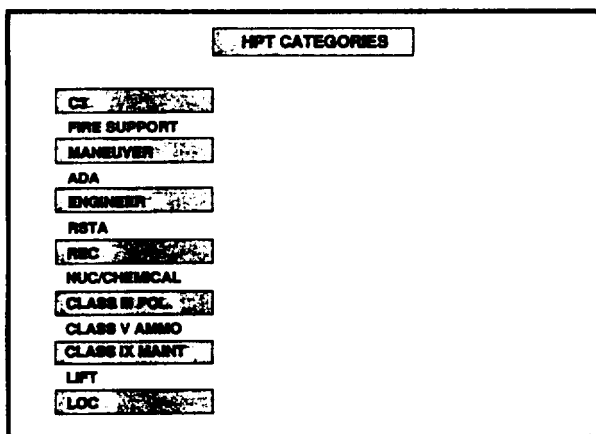

Figure 5-15. HPT categories

The targeting team then determines critical nodes within these categories. Within FS, a critical node might be artillery C² or cannon and rocket artillery that can range the division main attack. Within RSTA, it might be the enemy's division reconnaissance battalion.

The targeting team then determines which of the critical nodes division or supporting assets can detect and attack. The plans officer and deputy FSCOORD consider the HPTs in terms of their importance to the division plan and develop a prioritized list. This list may be an overall priority listing; priorities by phase of the plan; priority for deep, close, and rear operations; or a combination.

The targeting team must also determine the desired results of an attack on the HPTs. The element measures the results sought in terms of delay, disruption, or limitation of the enemy's force or capability. Delay is expressed in terms of time or events. For example, the desired results may be to delay uncommitted divisions for six hours or delay the enemy counterattack force until the division's exploiting brigade has passed through the penetration.

Disruption is expressed in terms of an enemy capability. It is less precise than delay or limitation. For example, the desired results of an attack might be to disrupt the enemy's fire support system (engaging the penetration of the main defensive position), or to disrupt his air defense (engaging the aviation brigade). In defensive operations, the result may be to disrupt the enemy's RSTA capability in the main effort's defensive sector.

Limitation is expressed in terms of geographical approaches. For example, the desired result of an HPT attack might be to limit the enemy's approach to a specific avenue of approach. In rear operations, the desired result might be to limit the enemy's capability for air assault on division's rear.

To achieve the desired results may require the division to integrate several actions into one coordinated effort against the HPT. Limiting the commitment of an enemy force into a given area may require integrating maneuver, fire support, and engineer assets. In rear operations, limiting the enemy's capability for air assault may require integrating engineers to create obstacles on likely LZs, and AD assets to control likely air avenues of approach. The commander may have to position FS assets to range likely LZs, and assign R&S tasks to rear operations units. He may also

position the reserve and TCF to enhance response time to air assaults.

The targeting team also develops target selection standards (see Figure 5-16) during the decide portion of the targeting methodology. It defines what sources or agencies will identify targets or suspected targets. The G3 and FSCoord use these standards during execution to determine which target information warrants commitment of attack assets. Discriminators used to determine target selection standards include—

- Target location error inherent to the system.
- Ž Susceptibility to deception.
- Ž Previously demonstrated reliability.
- Ž Weather.
- Enemy direction finding and jamming capability.
- Ž Rules of engagement.
- Ž Time since acquisition.

DIVISION		
	TARGET	SUSPECTED TARGET
G2	MUST SPECIFY	
FAIO	MUST SPECIFY	
CAVALRY SQUADRON		X
FIREFINDER RADAR	X	

BRIGADE		
	TARGET	SUSPECTED TARGET
S2	MUST SPECIFY	
IEWSE	MUST SPECIFY	
COLT	X	
AFSO	X	
FIREFINDER RADAR	X	

Figure 5-16. Target selection standards matrix

The targeting team then develops attack guidance which assists in synchronizing engagement of HPTs during execution. The attack

guidance gives the G3 and FSCoord a predetermined priority of targets to use during the battle. It assigns each HPT an attack parameter—immediate, as acquired, or plan.

Immediate means the target’s priority requires engagement as rapidly as possible, even if an ongoing attack must be suspended to shift assets to this target. An immediate HPT may require diverting artillery or CAS from a different target to this one.

As acquired targets are those the division should engage expeditiously, but do not warrant stopping another attack to do so. This may be a HPT of lower priority or with loiter time that allows the division to engage it as attack assets become available.

Plan means the target is included in a list of targets for future engagement. These HPTs are lower in priority, have a long loiter time, or are only critical at certain times or as certain events happen. They require division monitoring and location validation prior to the attack. For example, AD targets may be critical during an aviation brigade cross-FLOT operation but still not warrant immediate or as acquired priority. However, this parameter will involve committing resources to continue to monitor and track the target location. The attack guidance is normally prepared as a matrix. (See Figure 5-17, page 5-34.)

The targeting team determines the requirement to conduct target damage assessment during the decide process. Target damage assessment shows if the HPT attack achieved the desired results. The first decision is whether or not target damage assessment is required against the HPT. Some HPTs may not be suitable for development of timely target damage assessment. For example, disruption of AD capabilities or C² capabilities may be transient. The desired result may be achieved at the critical time and place. However, there may be no requirement or capability to conduct assessment. If a requirement exists to conduct target damage assessment, as in the case of delaying follow-on forces, the plans element must allocate resources and determine how to conduct it.

During the COA briefing and orders approval process, the targeting team (DFSCoord)

CATEGORY	HIGH PAYOFF	WHEN	HOW	RESTRICTIONS
1. (CS)	48 MECH DIV CP 481 REGT CP 483 REGT CP	P P P	EW EW EW	RESTRICTED FREQ LIST RESTRICTED FREQ LIST RESTRICTED FREQ LIST
2. (FB)	48 MRL BN	I	D	TGT LESS THAN 10 MIN OLD USE MLRS
3. (MAN)	484 REGT TAA	P	D	JAAT
4. (ADA)	TGT ACQ RADAR SA-6, SA-8, S-80	A P	D	USE MLRS G3 COORD WITH JAAT
5. (ENGR)	NOT HPT			
6. (RSTA)	48 RECON BN COUNTERFIRE RADAR	A A	N D	CTRRECON, EW USE MLRS
7. (REC)	JAMMERS	P	N	ADSO COORD W/G3
8. (NUC/ CHEM)	G2 SPECIFY	I	D	TDA REQUIRED
9. (POL)	NOT HPT			
10. (AMMO)	NOT HPT			
11. (MAINT)	NOT HPT			
12. (LIFT)	NOT HPT			
13. (LOC)	TAIs 25, 34, 19	P	N	GATOR, ARTY FASCAM

Figure 5-17. Attack guidance matrix

presents the results of the decide portion to the CofS, G2, G3, and division commander for approval. The commander ultimately approves HPTs, target selection standards, and attack guidance. During COA and order development process, the CofS coordinates the actions of the G2 and G3 operations elements at targeting board meetings, providing for parallel planning. Meetings occur as the elements transition from one plan to its sequel or at periodic intervals as listed in unit SOP. It allows the elements to make decisions which support the current operation and facilitate future operations, providing continuity to the targeting effort.

Detect

The detect portion of the targeting process includes allocating resources, developing the collection plan, assigning intelligence acquisition tasks, processing information into target intelligence, and disseminating target intelligence to attack systems. In the decide phase, the more specific the HPT targets, the more likely the G2 can identify, locate, and accurately target them.

The detect portion of targeting has a relationship to the attack system. If ECM assets are to attack the target to disrupt C², then the detect process not only includes a location but also technical data that ESM collected to jam the target effectively. If surface-to-surface indirect fires are to engage the target, detect includes an accurate target location and projected loiter time. If helicopters will attack the target, the need for location accuracy is less than for artillery. However, due to reaction time, target location must be projected and closely tracked. This allows the aviation brigade to conduct final preparations and update locations prior to executing the attack. The HPTs targeted for attack by AI require early identification, nomination, and continuous tracking because of the long lead times required for AI.

The G2 identifies, locates, tracks, and targets HPTs in his recommendation for IEW task organization and the division collection plan. Because of the limited range of division intelligence assets, he must coordinate with the corps collection manager to request intelligence for deep HPTs.

The G2 operations and ASPS detect HPTs for close and deep operations, relying heavily on corps and EAC intelligence products. The division detects HPTs with LRS teams, Quickfix, Q-37 counterfire radars, and TACAIR.

Within the division intelligence system, G2 ensures that all personnel are aware of division HPTs. The HPT list is distributed to G2 operations, the ASPS, and the TCAE as a ready reference, particularly as soldiers become fatigued.

The FAIO in the ASPS assists the G2. He ensures personnel are aware of the HPTs. He coordinates with intelligence managers to screen all intelligence for targeting information. He serves as a conduit to disseminate targeting information to the FSE.

The heart of the detection phase is the IPB process. The ASPS continuously updates the IPB to confirm or deny situational and event templates, using information provided by organic, supporting, higher, adjacent, and subordinate assets.

The EW section of the ASPS develops the electronic preparation of the battlefield (EPB) which supports the detection of HPTs. It tasks the TCAE to provide information to accomplish this. It also integrates information and intelligence from corps and EAC to assist in HPT development.

Reconnaissance reports support targeting in close operations. Intelligence acquisition tasks in the collection plan, or specific reconnaissance missions assigned to units by the G3, provide this information.

Counterfire radars provide accurate locations of artillery firing locations. These targets may have already been engaged, depending on their priority and division's attack guidance. However, their locations may assist the ASPS to adjust and update situational and event templates and assist in locating other HPTs. The DIVARTY counterfire officer must routinely pass radar acquisitions to the G2 special compartmentalized information facility.

Terrain analysis helps detect HPTs for rear operations. The rear CP identifies likely LZs and assigns surveillance responsibilities that are integrated with the air IPB. Air defense and Air Force early warning radars provide the enemy's air activity. The rear CP integrates this information with surveillance of likely LZs.

The G2 synchronizes HPT detection in deep, close, and rear operations using the situational, event, and decision support templates. These help him to coordinate and integrate resources at critical times to provide the targeting information required.

Committed forces detect HPTs in close operations. These include ground maneuver units, division IEW assets, artillery radars and FISTS, air cavalry troops, and aerial FS officers. These forces and assets detect both division HPTs and those of their respective subordinate maneuver commanders. They detect division HPTs as a result of intelligence acquisition tasks in the collection plan and through the reporting of combat information to the TAC CP.

The division commander and subordinate commanders may have different HPTs. The G2 may task the 1st brigade to identify and locate enemy AD in its sector in support of a cross-FLOT aviation mission. However, AD may not be a HPT

for the 1st brigade commander. His priority may be artillery and mortars arrayed against his main attack or RSTA elements. Conversely, a subordinate commander's HPT may duplicate those of the division commander. Coordination between echelons precludes duplicating effort and resources. The G2 operations at the main CP coordinates the collection effort with the subordinate commander's S2, integrating it into the division collection plan. Likewise, the G3 operations at the main CP coordinates the attack plan with the subordinate commander's S3 and integrates it with the division's attack.

The G2 operations at the TAC CP coordinates HPT detection in close operations using the HPTL, the DST, combat information from committed forces, and intelligence received from the main CP. He coordinates with S2s of committed forces and the G2 at the main CP to ensure collection assets focus on HPTs. As HPTs are detected, he informs the FSE and G3 for commitment of attack resources.

The G2 operations in the rear CP coordinates detection of HPTs in rear operations with the G2 in the main CP and base and base cluster S2s. His primary means of detecting HPTs are reconnaissance and surveillance efforts of base and base cluster commanders. Using doctrinal and situational templates as well as terrain analysis and the air IPB, he integrates and coordinates the R&S effort into one plan. This plan incorporates reports from MP traffic control, information from divisional counterintelligence, and interrogation of detainees.

Detection of HPTs in an enemy force requiring a Level II or III response to a rear area threat depends on contingency planning between the rear and main CPs' G2 operations. Intelligence and EW assets may be required to detect HPTs quickly and accurately to engage them with the TCF, supporting artillery, attack helicopters, or CAS. The G2 operations at the main CP coordinates, integrates, and synchronizes reallocation of assets.

Deliver

The deliver phase is the execution of the attack against the target. The G3 operations and FSE are the focal point. Using the prioritized HPTL, target intelligence from the G2, target

selections standards, and attack guidance, they direct the attack.

The G3 operations role in the deliver phase is to confirm HPTs and to direct their attack by maneuver forces. The FSE directs attack of HPTs by FS assets once they are detected and meet attack guidance.

Attack of HPTs in deep operations normally involves attack by AI or attack helicopters. The range of division attack assets normally does not reach uncommitted enemy forces. Deep maneuver, though an attack option, is a high risk.

The aviation brigade plans and executes attack of HPTs by attack helicopters. The division main CP integrates this attack as part of the concept of operations. Using the DST, the main CP G3 coordinates the attack time and location with the aviation brigade. He aids planning and execution by allocating resources and changing intelligence and FS priorities.

The FSE and G3 operations in the main CP coordinate and integrate attack of HPTs by AI. The FSE submits AI nominations to the corps FSE 24 to 36 hours prior to the desired attack. The division FSE submits periodic updates on the location and status of targets to the corps FSE. The G2 operations provides information for these updates. The division FSE informs G3 operations of the impending attack. The G3 operations either confirms the attack or requests diversion to a different target. The Air Force approves requests to divert after considering—

Ž Types of aircraft.

Ž Effectiveness of munitions against the new target.

Ž Enemy air defense in the vicinity of the target.

- Effects of weather on target engagement.
- Target distance from the old target.

Committed forces attack HPTs in close operations. Committed forces' CPs, and the TAC and main CPs, coordinate and synchronize the attacks. Attack assets include maneuver, FS, and engineers. Maneuver forces may attack enemy reconnaissance as part of counter-reconnaissance efforts. They may conduct limited objective attacks to disrupt AD during aviation operations. Smoke may be used to disrupt enemy

reconnaissance and target acquisition. Fire support may attack a range of targets including enemy mortars, artillery, AD, reconnaissance, and C² nodes. Engineers may place mines or demolitions to limit the enemy's avenues of approach or delay his arrival.

Attack of HPTs in support of rear operations may actually be conducted as part of the deep or close operations. These may include engaging air assault forces and support assets, long-range fire support, and infiltrating forces. In the rear area, attack of HPTs may be seen as counter-reconnaissance, surveillance, and security against SOF-type forces, or a Level II or III response to a rear area threat.

The rear CP coordinates and integrates base and base cluster plans to attack HPTs in the rear. It coordinates with the main CP to change priorities of fire support to engage HPTs. It directs Level II and III responses to rear area threats. The main CP coordinates and synchronizes these actions with deep and close operations. For example, it may have to divert CAS to support rear operations or change the priorities of CAS to synchronize with those of the close operation. The use of attack helicopters to support the rear CP may also impact on deep operations.

The main CP commands and controls the division targeting effort by executing branches to deep operations and integrating, coordinating, and synchronizing actions to support branches implemented by the TAC or rear CP. For example, it may request to divert an AI mission in deep operations requiring the TAC CP to implement a branch of the close operations plan. The TAC CP would issue a verbal FRAGO to execute the close operations branch.

The TAC CP may direct execution of branches of the close operations plan and coordinate them with the main CP. This ensures the attack of HPTs in the deep operation is synchronized with the close operations branch. As a result, the TAC CP may direct a new or revised HPTL and place attack guidance in effect. This may require changes to collection plans and priority to detect the HPTs. For example, the opportunity to effectively employ a JAAT in the close operation may require changing AD targets from plan to as acquired.

SUPPRESSION OF ENEMY AIR DEFENSE OPERATIONS

Division air assets must survive to contribute their full combat potential. For this reason, SEAD is critical. It must be accomplished quickly and efficiently to support aviation operations.

Suppression of enemy AD is a concurrent operation inherent in division aviation missions. The concept of the aviation mission determines the complexity of the supporting SEAD operation.

When the division commander decides to commit the aviation brigade, the aviation brigade plans SEAD support for the mission. The division supports the aviation brigade commander and his staff and synchronizes overall operations, to include SEAD.

The division has the primary responsibility to support suppression of ground-based enemy AD weapons to the limits of observed fire. Targets that observed fire cannot engage are the primary responsibility of the Air Force. In this area, the division has secondary responsibility out to the range limit of its indirect fire weapons. In most situations, the division can suppress targets with unobserved indirect fire, if they are accurately located.

The division supports SEAD operations with specific critical combat and CS elements to synergize combat power against the enemy's air defense. Unity of effort is essential and requires detailed planning, close coordination, and precise timing.

SEAD Categories

There are three categories of SEAD operations—campaign, localized, and complementary. Within each category, SEAD may be destructive or disruptive.

Destructive SEAD destroys surface-to-air defenses or personnel. Its effects are cumulative and steadily reduce aircraft attrition. Destructive SEAD, employed alone, places large demands on combat power. The commander must integrate destructive SEAD with disruptive SEAD, such as jammers, which are generally reusable resources.

Disruptive SEAD can temporarily degrade, deceive, delay, or neutralize surface-to-air defenses or personnel. There are two types of

disruptive SEAD—active and passive. Active suppression includes jamming, chaff, flares, and tactics such as deception, avoidance, or evasive flight profiles. Passive suppression includes camouflage, infrared shielding, warning receivers, and materiel design features.

Disruptive SEAD complements destructive SEAD. It can—

- Degrade jammable threats.
- Ž Assist destructive airborne suppression systems in suppressing surface-to-air defense systems.
- Ž Temporarily degrade or neutralize enemy AD systems when their destruction is not possible or feasible.
- Ž Sustain suppression effects achieved by destruction once threats are at levels commensurate with joint suppression of enemy air defense (JSEAD) objectives.

Campaign SEAD

Divisional artillery, IEW, and aviation assets may join in suppressing campaign SEAD targets; however, corps or Air Force assets usually engage these targets when they are available. The division uses artillery to its maximum range to destroy accurately located targets. It employs IEW assets to jam, degrade, or disrupt enemy AD systems. Although Army aviation assets are not a primary weapons system for SEAD operations, the division may use them to engage deep campaign SEAD targets.

Localized SEAD

The division conducts localized SEAD to support cross-FLOT operations as part of its scheme of maneuver. Indirect fire support weapons and IEW assets are the primary systems used to open corridors or suppress specific attack objectives. Suppression will begin prior to arrival of the aircraft, and should continue as long as aircraft are in range, unless aircraft would be endangered by the system suppressing the ADA. Egress routes are established and suppressed in a similar manner. Coordination, synchronization, and timing are critical to the success of these operations; fire support, Army airspace command and control (A²C²), and TACAIR control systems coordinate these aspects with aviation elements conducting cross-FLOT missions.

Complementary SEAD

Divisions conduct complementary SEAD continuously. They attack enemy AD targets of opportunity that can adversely affect current or future aviation operations when they are identified and located, and when attacks are consistent with available resources and commander's priorities. The FSE may prioritize complementary SEAD efforts in specific areas to facilitate a future aviation mission. When this exceeds the division's capabilities, the G3 requests support from corps.

Division SEAD Operations

The best protection against every air defense is to select enemy routes that avoid ADA. The routes selected determine the resources required to conduct an effective SEAD program. The G3 must consider factors of METT-T as he develops COAs for cross-FLOT or near-FLOT employment of the aviation brigade. He must ask: Is this an attack mission? Against what? Is it an aviation mission to support an air assault? Is it an aviation mission to insert a LRST?

Key considerations in staff estimates which may impact division support of aviation brigade's SEAD operations include—

- What is enemy force and status (not just the enemy ADA)?
- Ž Is the enemy attacking or defending?
- Is the division facing the enemy's main or supporting effort?
- Ž Does terrain reinforce nap-of-the earth flights or have the effect of segmenting the enemy ADA?
- Ž Does terrain result in radar blind spots the division can exploit?
- Does weather favor use of aviation assets?
- What current division operations will impact on troops available to support the SEAD program for the aviation mission?
- What, if any, intelligence collection will have to be reduced or terminated to support the development of SEAD targets?
- Was ADA already identified as a HPT?

- Has intelligence developed and maintained a good enemy AD data base or will collection assets have to be redirected to target ADA? (An electronic intelligence (ELINT) or communications intelligence (COMINT) report on ADA used for situation development may be insufficient for artillery targeting.)
- What attack assets are available to support the SEAD program?
- Will they have to reposition?

Ž Do attack assets have the correct amount and types of munitions?

Staff Responsibilities

Suppression of enemy air defense is a force protection requirement inherent in aviation operations. The division aviation brigade plans, prepares, and executes SEAD in support of its operations. The division commander and staff synchronize SEAD support for aviation operations with the division's current and future operations.

G3. The division G3 coordinates with the aviation brigade's S3 during development of the mission. He coordinates, integrates, recommends, and synchronizes changes to priorities and task organization to support the aviation brigade. The aviation brigade S3 integrates and synchronizes these assets and capabilities into the aviation brigade plan.

The aviation brigade S3A²C² element plans, coordinates, and submits air corridors to G3 operations A²C² element for synchronization and division commander approval. The G3 may synchronize a ground attack with an air operation to open a corridor. A forward thrust by maneuver forces may effectively disrupt the enemy and his forward air defense system. Direct fire weapons of the maneuver units are the most responsive and effective means of attacking close-in AD targets. Since the enemy may locate significant AD near the FLOT, planners should look for opportunities to bring ground and air penetrations together in time and space to benefit from each. Maneuver units engaging enemy AD systems report them through operations channels in accordance with unit SOPs.

The aviation brigade S3 coordinates FARPs, forward assembly areas (FAAs), and other terrain requirements with committed maneuver brigades. The G3 resolves conflicts or recommends solutions to the division commander.

Although there may be exceptions, the G3 will not normally assign SEAD missions to aviation units. Aviation contributes to complementary SEAD by engaging targets of opportunity and through self-defense tactics. Army aviation can also call and adjust fires against enemy targets. This capability can extend the division's range of observed fires significantly.

The G3, assisted by the A²C² element, synchronizes air corridors for the aviation brigade. Synchronization is based on—

- Current and future airspace control measures.
- Current and future artillery and AD locations.
- The enemy's AD situation and probable COA.
- Weather and terrain.
- Capabilities of friendly aircraft.

The aviation brigade representative in the division A²C² element coordinates this with and for the aviation brigade.

G2. Situation and target development is critical in SEAD. Working closely with the aviation brigade S2, the G2 directs intelligence organizations to identify and locate enemy AD order of battle. He also finds critical nodes which, if interdicted, will significantly degrade enemy capability. He integrates the aviation brigade commander's PIR and IR, and requests for intelligence information, into the division collection plan.

Based on the aviation brigade mission, the G2 may recommend changes to the division commander's PIR and IR. However, he must ensure that they support the division operation, not just the SEAD for the aviation brigade.

The G2 uses down links of corps and EAC assets to obtain real-time or near real-time combat information and targeting data. He develops AD radar locations from ELINT down links. He may direct GSRs to track the AD radar location as it moves.

The aviation brigade S2 forwards requests for intelligence information to committed maneuver units to determine enemy AD locations in their AOs. He integrates this information with intelligence received from the G2 and develops and disseminates target information to the aviation brigade FSE.

Fire Support Element. The FSE recommends to the G3 required changes to the artillery task organization and priority of fires to support the aviation brigade. It may recommend a mix of DS, reinforcing, or GS-reinforcing artillery, or it may assign the aviation brigade priority of fires for a specific mission. METT-T will influence the method chosen.

The FSE also may recommend changes to the division HPTL, attack guidance matrix, and target selection standards. Depending on the time available, the FSE may direct repositioning FS assets to support the overall mission, as well as provide SEAD support for the aviation brigade's mission. Artillery units support the operation with preplanned fires and on-call missions. Electronic warfare assets degrade the effectiveness of enemy air defense by jamming keyC² nets.

The FSE coordinates additional fires for the aviation brigade as requested by the brigade FSO. The FSE also coordinates SEAD for targets outside the division's boundaries, but capable of ranging air corridors.

The opening of a corridor is a major operation requiring a heavy commitment of resources. Only a limited number of corridors can be established in a given period of time. Therefore, the division FSE must coordinate with adjacent and subordinate units to ensure all division suppression operations are mutually supportive and capitalize on enemy vulnerabilities.

Division artillery systems can destroy accurately located enemy AD targets. Artillery may also engage suspected enemy AD targets. Smart munitions and advanced sensors can reduce the problem of target location if the location is within the sensor's area.

Use of artillery smoke in SEAD operations can be both an advantage and a disadvantage. Smoke can hide aircraft from enemy AD weapons that use visual acquisition. However, it

is ineffective as a countermeasure against electronic sensor-guided AD systems. It can also obscure targets and prevent friendly aircraft from identifying enemy AD weapons. Smoke is a limited resource; its use must be planned and coordinated carefully.

The MLRS, if available to the light division, is an effective weapon for SEAD. The dispersion of MLRS bomblets makes it an excellent weapon against thin-skinned AD weapons and radars. MLRS can create corridors at the FLOT or engage several targets with its multiple aim point capability.

Jamming enemy AD system C² nodes has two objectives. First, it can force enemy firing units to activate their radars to acquire targets rather than relying on the C² system, and thus expose themselves to acquisition and attack. This is useful, however, only if systems are poised to attack when the enemy activates its radars. Second, jamming also degrades C² systems during friendly air operations. This type of suppression requires close coordination of flight and jamming schedules. Because of the limited number and capabilities of division jammers, the EW staff officer in the FSE synchronizes jamming of SEAD targets with the total division ECM effort.

An Example

This section provides an example of how a division plans and executes SEAD in support of an aviation brigade cross-FLOT operation. The division commander has decided to attack a regiment identified as the enemy's counterattack force to prevent its use against the division as it attacks. The division is conducting offensive operations as part of a corps deliberate attack. The division is not the corps main attack.

The enemy opposing the division occupies deliberate defensive positions and consists of elements of an infantry division at approximately 40 percent combat effectiveness. Air parity exists in the theater with either side capable of achieving local air superiority for short periods. Ninety-six hours earlier, the division received this mission:

Ž To conduct a relief in place.

- To attack, on order, as the corps supporting attack, to penetrate the enemy defense.

- To be prepared to pass an armored division to exploit in the enemy's rear.

The division is at 98 percent combat effectiveness. It completed the relief in place 24 hours before as part of a regeneration of the corps' combat power. The corps' FRAGO to attack is received 18 hours prior to H-hour.

Once the enemy infantry regiment is identified as a HPT, the intelligence system focuses on it to detect its location and movement. The intelligence staff uses analysis of the terrain, weather, and enemy doctrinal and situational templates to develop possible enemy COAs. The G2 establishes NAIs and TAIs. The NAIs will confirm or deny the enemy's COA while the TAIs will become the EAs for the attack on the regiment. These areas are highlighted in the collection plan with additional assets allocated to ensure redundancy of collection to increase timely information on the enemy regiment's movement.

The division commander assigns the cross-FLOT attack mission to the aviation brigade. The G3 establishes priorities and allocates resources to the aviation brigade to conduct the attack. These included priority of fires. The aviation brigade conducts detailed planning and preparation for the mission, including SEAD planning.

The aviation brigade A²C² element coordinates air corridors to attack the enemy regiment to avoid concentrations of enemy air defense. The A²C² element considers existing low-level transit routes (LLTRs) in effect or projected to take effect. This allows planners to take advantage of scheduled AF jamming and operations conducted in support of AF missions. Planners also consider the terrain, projected weather, and aircraft survivability capabilities. The brigade S2 and FSO conduct their planning and preparations based on these air corridors.

The aviation brigade A²C² element provides the division A²C² element the proposed air corridors, which it coordinates with the committed maneuver brigade's S3 air and corps A²C² element. The division A²C² element synchronizes these corridors with the concept of operations and scheme of maneuver. The G3 air recommends approval to the G3 and the division commander approves them.

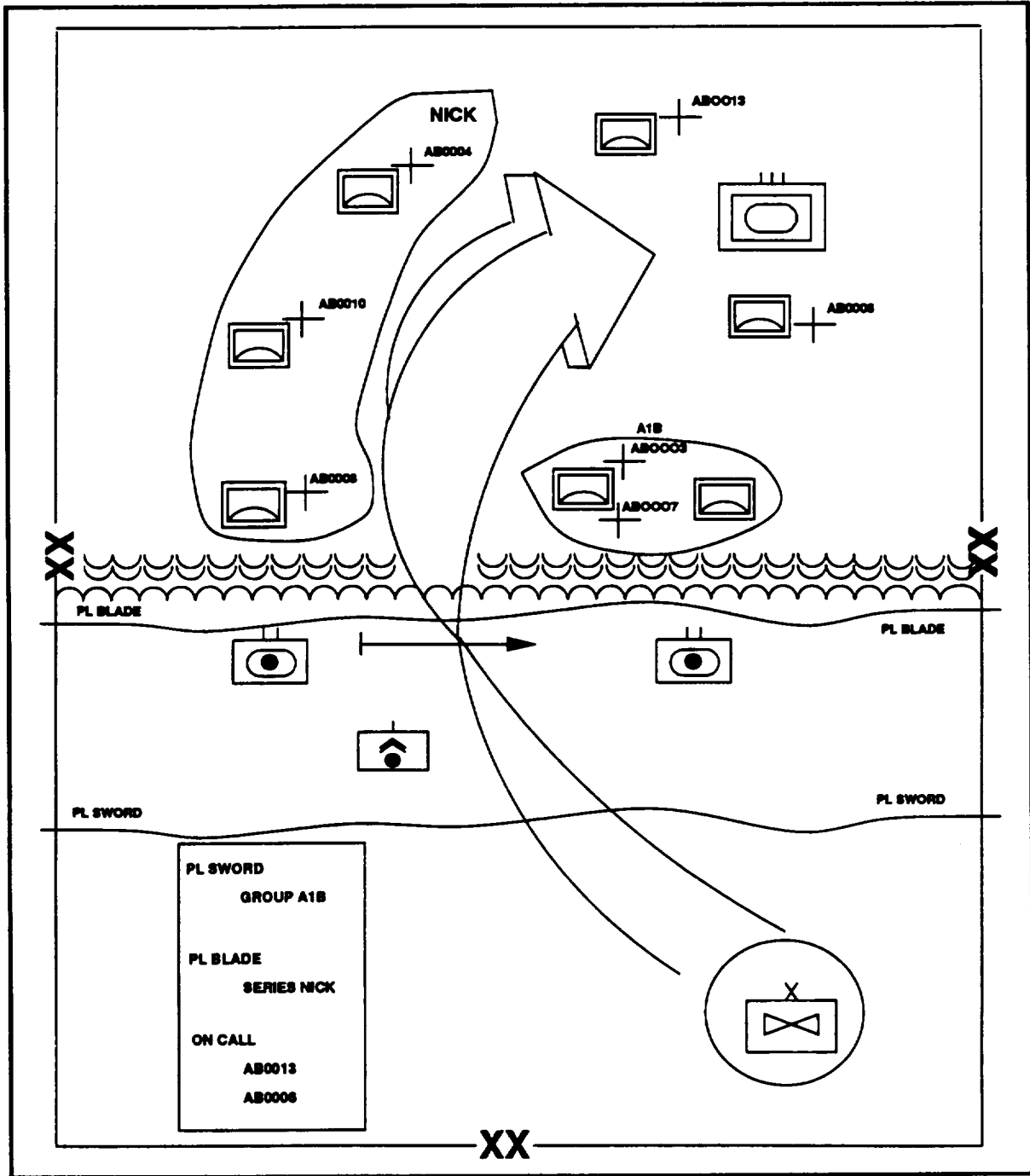

Figure 5-18. SEAD plan

The aviation brigade S2 recommends changes to the aviation brigade commander's PIR and IR. He requests enemy AD locations from higher and adjacent units and provides target information to the FSO to plan attack of these targets.

The aviation brigade FSO develops the SEAD program from targets received from the S2. He tasks supporting FS assets and requests support from division for targets beyond the brigade's capabilities. Jamming assets are tasked to

suppress C² systems of the enemy AD assets facing the division.

The aviation brigade FSO coordinates the positioning and munition requirements for the SEAD with the DIVARTY. He coordinates ECM targets through the EW staff officer in the main CP FSE.

The SEAD targets are verified prior to launching the attack. The field artillery intelligence officer in the ASPS is also a key source for target updates.

To simplify C² for executing SEAD, the FSO plans SEAD as individual targets, groups, and series. These targets are included in an execution matrix which is provided, along with the SEAD program, to units scheduled to fire the SEAD. Using an execution matrix, the FSO for the air battle captain directs execution of the SEAD. Attack helicopters engage targets of opportunity or these targets are transmitted as an immediate suppression or fire-for-effect mission to the FSO. (See Figure 5-18, page 5-41.)

The aviation brigade commander reviews the updated plan and gives the execution order to the air mission commander. As part of the final preparation, the air mission commander conducts a rehearsal with the aviation brigade FSO, artillery units, ECM assets, and his subordinate commanders participating.

During the mission, the air mission commander directs the execution of SEAD targets as the mission progresses and calls for fire at targets of opportunity for the duration of the mission, including the recrossing of the FLOT.

On completion of the cross-FLOT mission, the aviation brigade commander and staff conduct an analysis to determine its effectiveness. The SEAD planning process continues, to ensure maximum planning before any future commitment of assets to further cross-FLOT operations.

ARMY AIRSPACE COMMAND AND CONTROL

Successful division operations and engagements may depend on the effective use of airspace over the AO. Within this airspace, a high density of friendly weapons systems and aerial vehicles with overlapping operating envelopes and flight

profiles must contribute to combat effectiveness without interfering with one another, hindering the efforts of friendly combatants, and causing fratricide.

Division A²C² consists of all actions required to synchronize airspace use. The division A²C² element performs these actions under the supervision of the G3 air. The A²C² element coordinates airspace user requirements with the commander's plan for effective airspace use over the division's AO. The A²C² element is a separate cell in the division main CP, normally located near the division FS cell. Its primary tasks include—

- Identifying and resolving airspace user conflicts.
- Coordinating and integrating airspace user requirements within the division's AO and with other services and adjacent units.
- Maintaining A²C² information displays and maps.
- Developing and coordinating airspace control SOPS, plans, and annexes to division OPORD and OPLANs, and disseminating airspace control orders, messages, and overlays.
- Approving, staffing, and forwarding to corps requests for airspace control measures requiring airspace control authority (ACA) approval and special use airspace.

To accomplish these tasks, A²C² elements must continuously update the G3 air and A²C² displays and maps. This coordination helps synchronize combat power within the limited airspace over the division's AO.

Airspace Control Measures

To meet the requirements of simplicity and flexibility, the A²C² element methodology stresses procedural control. Procedural control is conducted through the use of airspace control measures and standard operational procedures (air, axis, air corridor). Figure 5-19 depicts airspace control measures available to provide procedural control. Airspace control measures requiring ACA approval are forwarded through the corps A²C² element for approval as shown in Figure 5-20, page 5-44.

MEASURE	USAGE
CORRIDORS AND ROUTES:	
AIR ROUTE	NATO/ASCC
LOW-LEVEL TRANSIT ROUTE (LLTR)	NATO/ASCC
MINIMUM RISK ROUTE (MMR)	US
STANDARD USE ARMY AVIATION FLIGHT ROUTE (SAAFR)	US
SPECIAL CORRIDOR	NATO
TRANSIT CORRIDOR	NATO
ZONES	
BASE DEFENSE ZONE (BDZ)	NATO
HIGH DENSITY AIRSPACE CONTROL ZONE (HIDACZ)	US/NATO/ASCC
RESTRICTED OPERATIONS ZONE (ROZ)	US/NATO/ASCC
WEAPONS FREE ZONE (WFZ)	NATO
FLIGHT LEVELS	
COORDINATING ALTITUDE (LEVEL)	US/NATO
TRAVERSE LEVEL	US/NATO
OTHER AIRSPACE SUBDIVISIONS OR CONTROL MEASURES:	
AIRSPACE COORDINATION AREA	US/NATO
AMPHIBIOUS OBJECTIVE AREA	US/NATO
TERMINAL CONTROL AREA (ZONE)	US/NATO
WEAPONS ENGAGEMENT ZONE	US/NATO
CONTROL POINT	US/NATO
WAY-POINT	US/NATO
TIME SLOT	NATO/ASCC

Figure 5-19. Airspace control measures (procedural)

To separate rotary- and fixed-wing aircraft, the air component commander (airspace control authority) designates an airspace control measure in the form of a coordinating altitude. (See Figure 5-21, page 5-44.) Rotary-wing aircraft normally operate below the coordinating altitude, and fixed-wing aircraft, above it. The coordinating altitude assigned to rotary-wing aircraft may be below the altitude assigned to fixed-wing aircraft, thus creating a buffer zone. The following paragraphs discuss airspace control measures the division uses.

A *weapons free zone* (WFZ) (Figure 5-22, page 5-45) is an AD zone established for the protection of key assets or facilities of the joint force other than air bases. Air defense artillery systems within a WFZ are normally maintained at a

weapons control status of weapons free. Aircrews must avoid active WFZs, or coordinate with the designated control authority prior to entry or prior to transit through a WFZ.

A *high-density airspace control zone* (HIDACZ) maybe requested by a maneuver force commander and must be approved by the ACA. This airspace control measure reserves airspace. It also controls which airspace users have access to the zone. (See Figure 5-23, page 5-45.) By establishing a HIDACZ, the commander forces other airspace users to operate elsewhere or under the conditions and restrictions approved by the authority. The establishing (requesting) commander must control all air space use within the HIDACZ. In addition, the commander controls the weapons control status within this area.

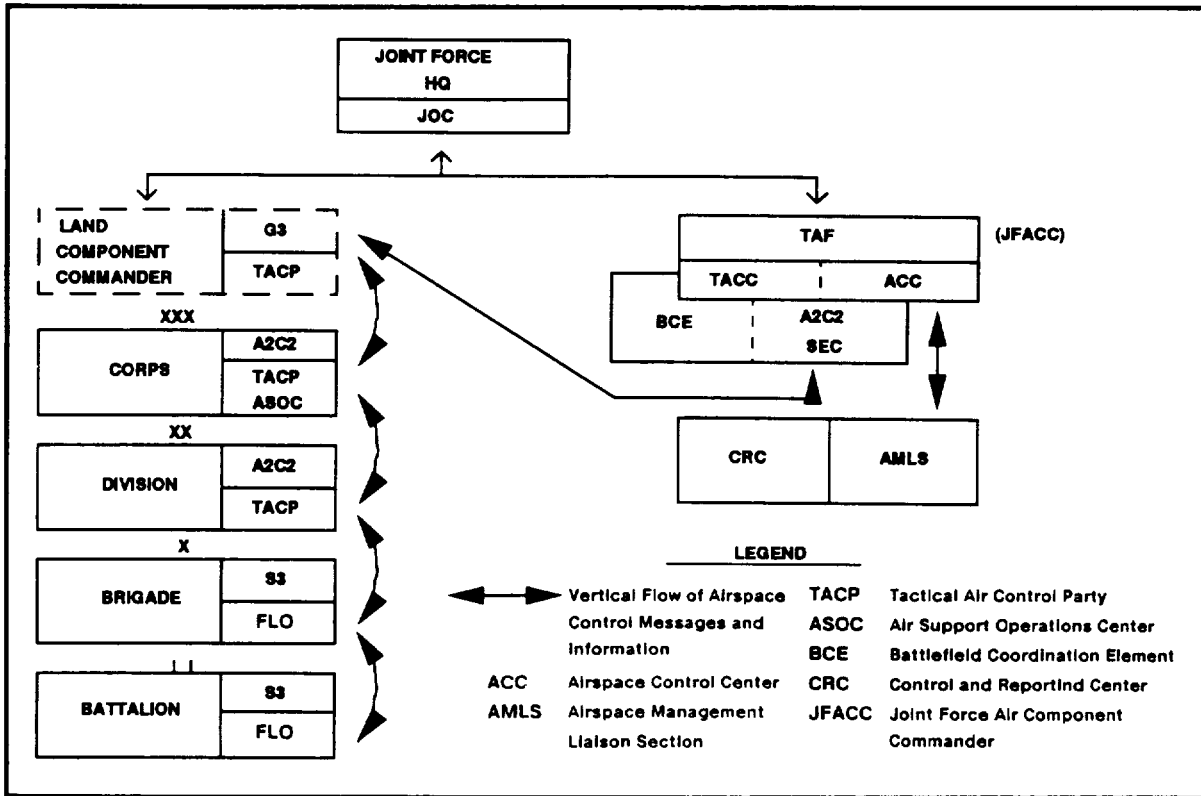

Figure 5-20. Airspace control channels

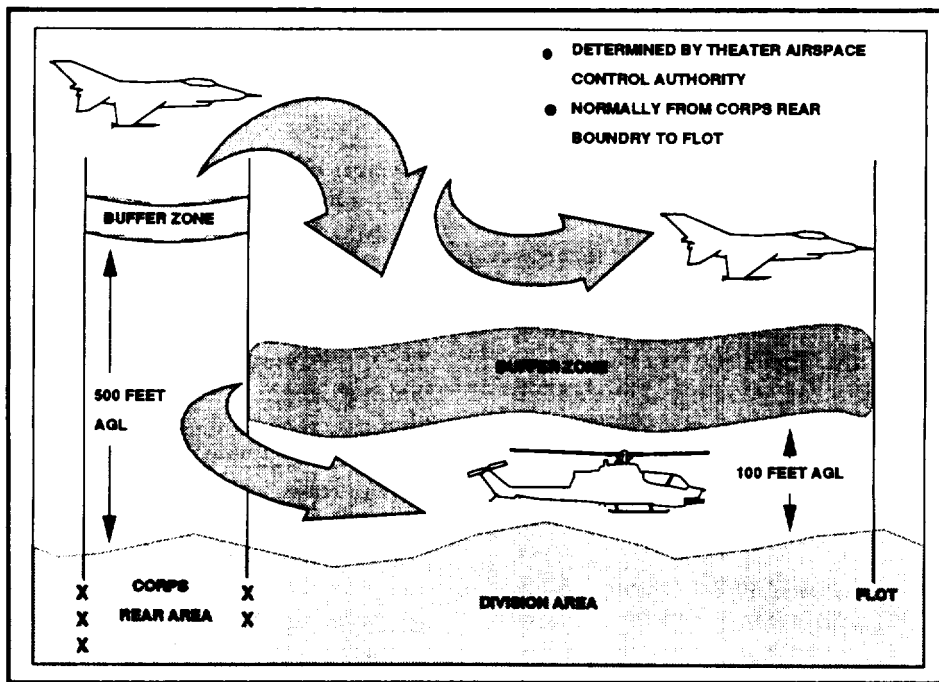

Figure 5-21. Coordinating altitude (level)

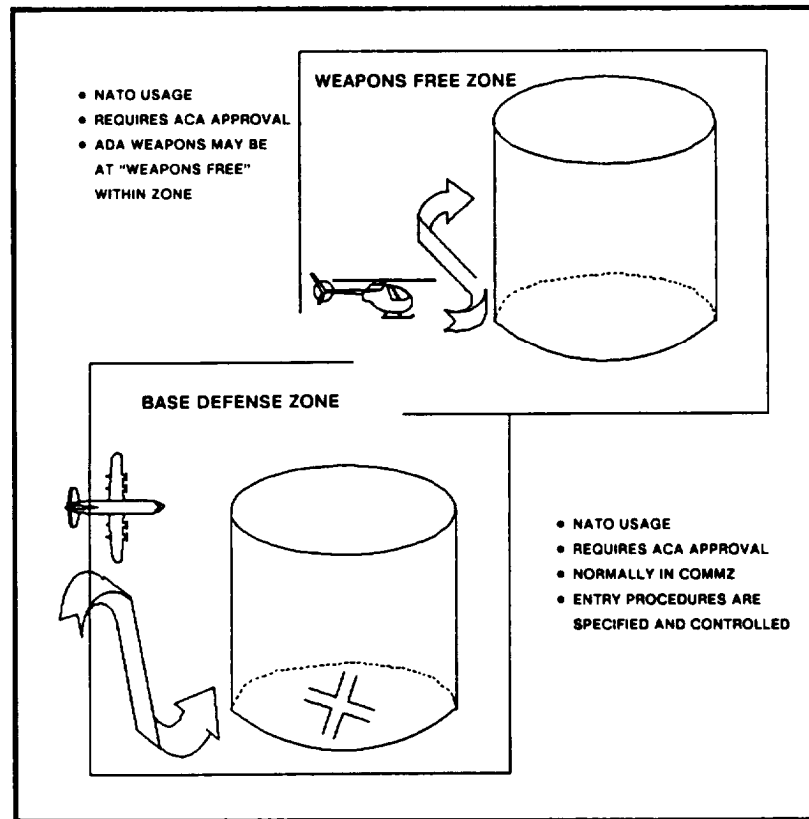

Figure 5-22. Base defense and weapons free zones

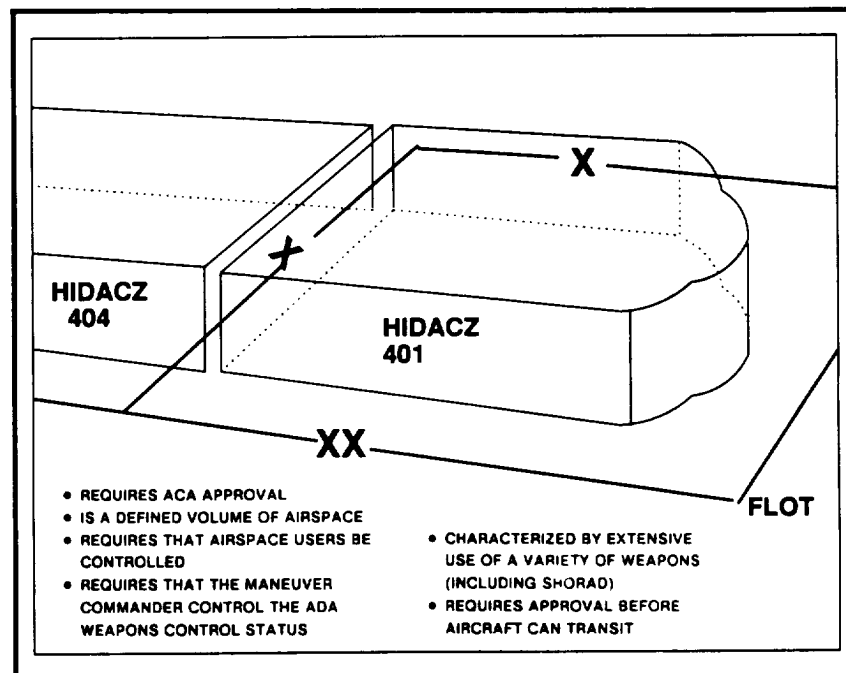

Figure 5-23. High-density airspace control zone

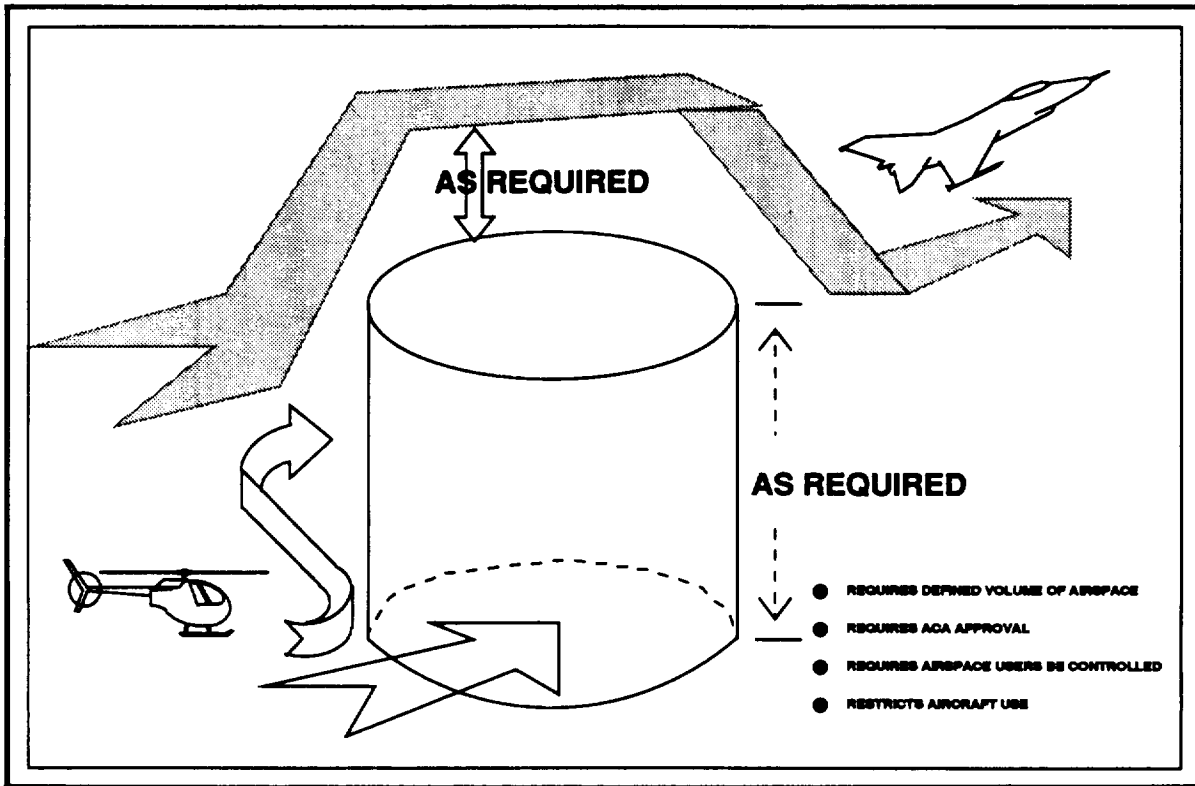

Figure 5-24. Restricted operations zone

A *restricted operations zone (ROZ)*, also known as an *airspace restricted area*, is airspace of defined dimensions developed for a specific mission or requirement. (See Figure 5-24.) A ROZ restricts some or all airspace users from the area until the end of the mission. A ROZ supports DZs, search and rescue operations, special electronic mission aircraft orbits, and UAV launch and recovery sites. A ROZ may facilitate AD operations in a given area by preventing friendly aircraft from entering airspace. The commander's A²C² element requests a ROZ through the appropriate A²C² element to the ACA. The ACA Coordinates requirements for temporary ROZs and evaluates their impact on other airspace users. Controlling authority requirements for the ROZ are similar to those required for a HIDACZ, with the exception of the ADA weapon status.

A *minimum risk route (MRR)* is a temporary route of flight which presents the minimum known hazards to low-flying aircraft transiting

the combat zone. It normally extends from the air route structure in the communications zone (COMMZ) through the Army, corps, and division area, across the FLOT, and terminates near the FSCL. The MRR is synonymous with low-level transit route (NATO term).

A *low-level transit route (LLTR)* (see Figure 5-25) is a temporary corridor of defined dimensions which allows the low-level passage of friendly aircraft through friendly air defenses and controlled or restricted airspace. The ACA specifies the number of LLTRs (active and on-call) to accommodate air operations. Division and corps nominate the actual trace on the ground which the LLTR follows. The A²C² element, with AF coordination and assistance, plans it. The routing accommodates transiting aircraft but avoids critical areas and assets defended by ADA. It also stays clear of areas of anticipated intense combat operations (for example, an axis of main attack).

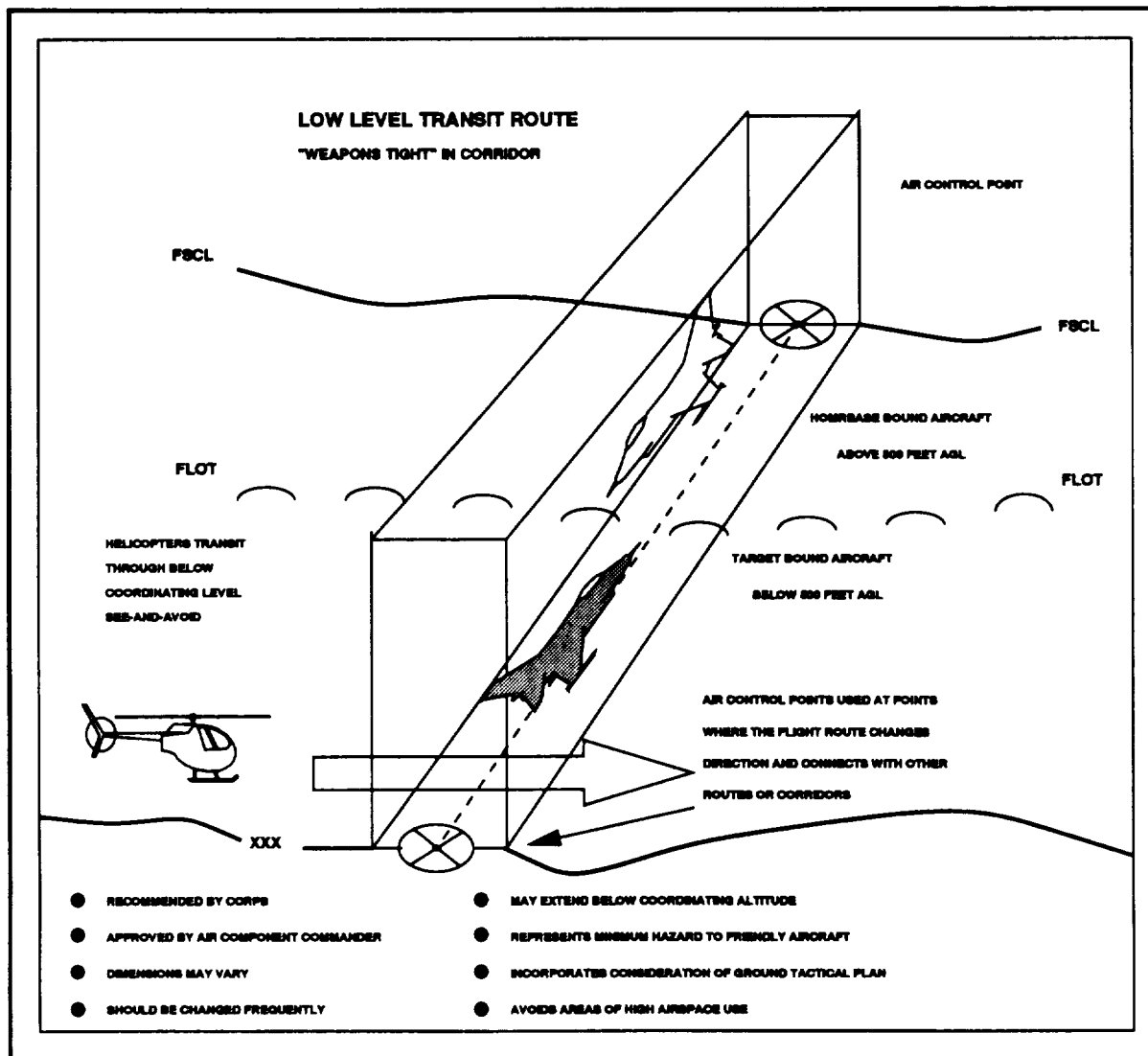

Figure 5-25. Low level transit route

Additionally, airspace planners establish the route trace to avoid—

- Concentrations of FA units.
- Significant groups of FS targets.
- Landing and drop zones, FARPs, landing sites, and airfields.
- Known enemy ADA systems.
- Other planned or active special use airspace (for example, ROZs, and special corridors).
- Friendly ADA firing batteries or units.

A standard use army aircraft flight route (SAARF) (Figure 5-26, page 5-48) is a route established below coordinating altitude to aid movement of Army aviation. Normally in the corps and division rear AO, it is a recognized Army airspace control measure that does not require joint approval by ACA. The A²C² develops SAAFRs to safely route Army helicopters conducting CS and CSS missions. They are intended primarily for single aircraft or for small flights of aircraft operating routinely between base clusters in the DSA and in corps rear area.

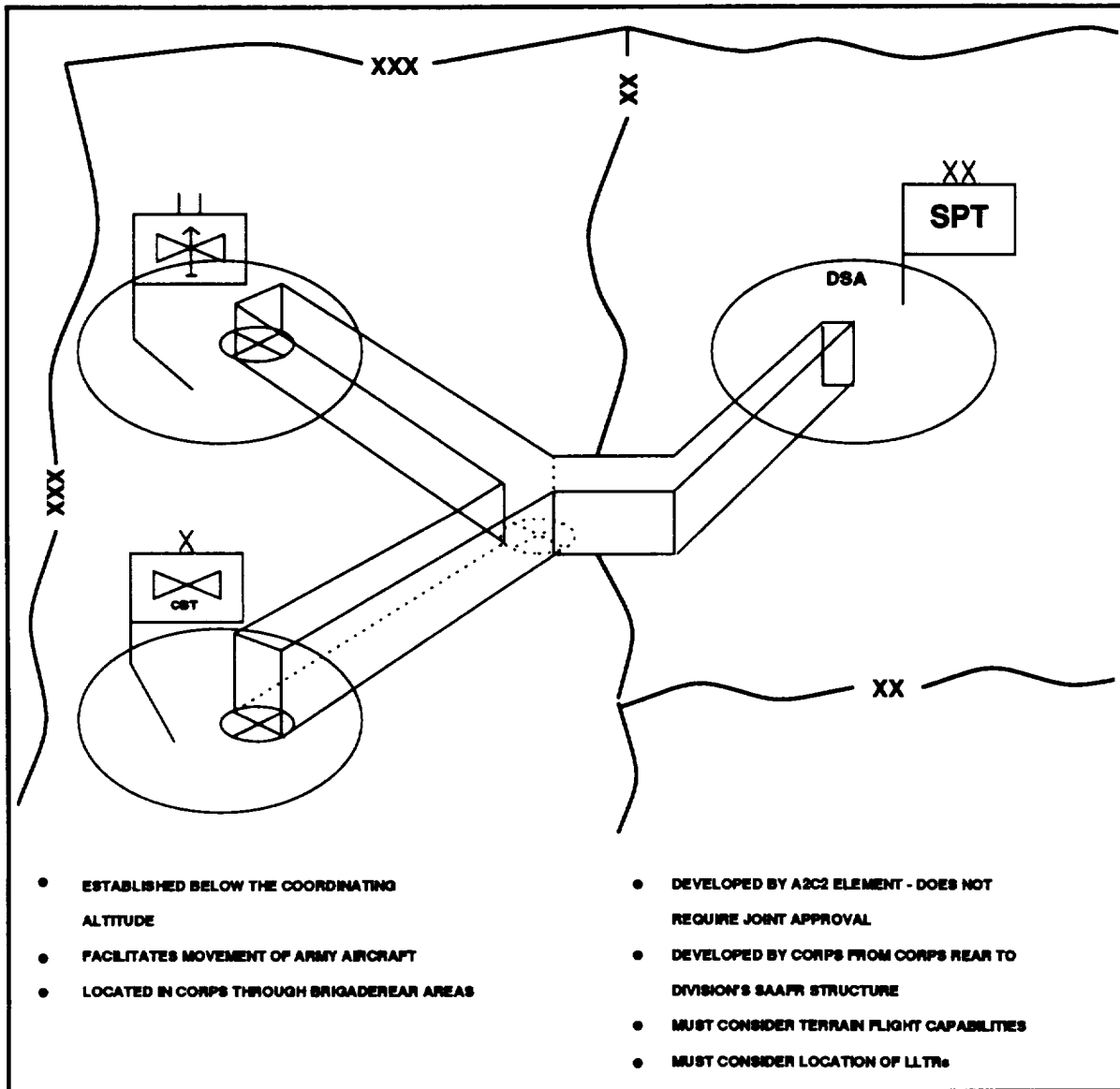

Figure 5-26. Standard use Army aircraft flight route

An *air corridor* is a restricted air route for use by Army aircraft and to prevent friendly forces from firing on friendly aircraft. Air corridors are standard Army operational procedures. They do not require ACA approval as they are employed within the terrain flight environment, normally in the division AO and deep operations area. Air corridors are temporary, established as required to route combat elements of the division and corps aviation brigade between assembly areas, holding

areas, battle positions, FARPs, and target engagement areas. (See Figure 5-27.)

Air corridors can serve as control measures during air assault operations, and as routes for air assault forces during the air movement phase. Helicopters conducting air movement operations within the corps and DRA can use them. Standard measures for air corridors include air control points (ACPs), communications check points,

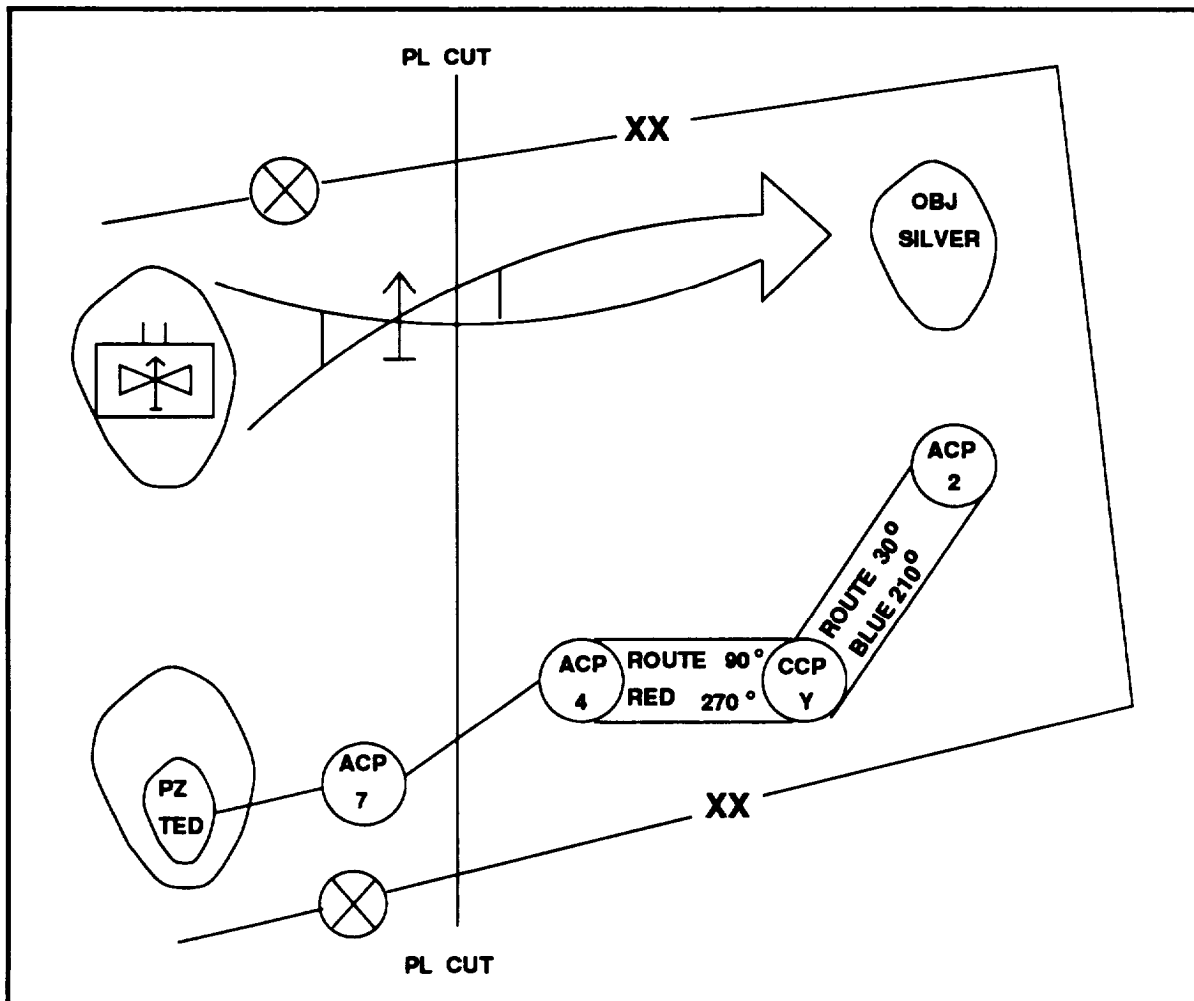

Figure 5-27. Graphic depiction of air corridor and air axis

magnetic azimuths of the routes of flight, PZs, LZs, and initial points (IPs).

The aviation LO, in coordination with the A²C² element, selects the ground trace of an air route and depicts it graphically on the OPORD overlay. Terrain, enemy AD, and ground maneuver plans influence the need for and location of air corridors.

Command Post Functions

The division A²C² element functions under the staff supervision of the G3. The G3 air supervises the operations of the A²C² element. The A²C² element is staffed for 24-hour operations.

The A²C² element at the main CP is the focal point for all airspace control activities related to division operations. Close coordination is maintained between the TAC CP, the rear CP, and the A²C² element at the main CP. This ensures airspace requirements generated by changes to the tactical situation are met timely and effectively.

No formal A²C² element exists at the TAC CP. Selected TAC CP staff and liaison elements perform airspace control as collateral functions. The division A²C² element comprises the G3 air element, ADA element, aviation element, and ALO.

The A²C² element often includes an MI brigade LO and an ATS LO. The A²C² element constantly coordinates with the—

• FSE.

• Aviation brigade.

• ADA battalion.

• ATS unit assigned to the division.

• G2 section.

• G4 section and, when required, the air and naval gunfire liaison company (ANGLICO).

• A²C² elements and brigade S3 airmen.

The A²C² staff sections and liaison elements are represented only within the main CP.

Personnel assigned to A²C² accomplish two primary tasks. First, they assist in coordinating their parent units' assets, provide technical expertise, and serve as liaison between the commander, his headquarters, and their parent units. Second, they synchronize airspace requirements of their parent units with other airspace users of the combined arms team and services. As an additional task, A²C² staff often obtain and pass battle damage assessment information from A²C² channels to the G2 staff.

Personnel performing A²C² staff functions require an in-depth knowledge of A²C² doctrine and procedures, corps and division airspace control plans, and division airspace control SOPS. This requires personnel be assigned full-time staff duties in the A²C². It is recommended that A²C² personnel receive formal training (for example, the Air-Ground Operations School).

Tactical CP

The G3 operations cell responds to airspace conflicts in close operations as required based on information provided by committed forces and the main CP A²C² element. The operations section maintains and displays unit locations down to battalion level. Committed forces provide their OPLAN and OPORDs, graphics, and FRAGOs to the operations section. The FS cell receives and maintains locations of artillery and AD units and their coverage and range fans. The air liaison officer has information concerning sorties—how many, when, and where. He also has information on MRRs, CPs, and IPs that are in effect. The

A²C² element at the main CP provides the TAC CP with effective or planned air corridors affecting the close area of operation. By using standardized overlays, the G3 operations cell can readily identify airspace conflicts or likely conflicts. The G3 operations cell can then request the A²C² element to resolve the conflict with affected units. In time-critical instances, the TAC CP may issue directives to resolve an immediate conflict and then pass overall synchronization to the A²C² element at the main.

Main CP

The A²C² element at the main CP is the focal point for A²C² in the division. It synchronizes airspace use for current deep, close, and rear operations and provides input and technical expertise to the plans cell for future operations.

Various organizations and CPS provide the information required to synchronize the use of the division's airspace. The A²C² element keeps this information on one A²C² map. The G3 air must keep up to date on branches and sequels to the current deep, close, and rear operations.

Support of current deep, close, and rear operations begins with the planning, coordination, and approval of airspace control measures implemented by the division or the ACA. In the case of LLTRs and MRRs, the A²C² receives input from committed unit S3 airmen, correlates the information, and provides it to the corps A²C² element. This is done routinely in cycles every 8, 12, or 24 hours. Recommendations are based on the division's and brigade's missions, concepts of operations, and intent. The objective is to preclude airspace control measures from restricting ground operations—especially artillery, mortar, and AD operations. War-gaming the concept of operations and branches and sequels should indicate artillery, AD, and Army aviation locations to avoid. On-call airspace control measures should also be developed to support various branches and sequels.

During operations, the A²C² element must anticipate activating airspace control measures to preclude airspace conflicts. Members of the A²C² element must review the air control order as it is received to identify conflicts. For example, GS AD assets positioned in a LLTR may require repositioning.

Artillery units positioned in a division air corridor or positioned so that their trajectory crosses an air corridor may have to reposition to fire SEAD missions in support of aircraft using the corridor. In each case, there are other options besides repositioning. These include establishing airspace coordination areas for the artillery or changes to weapons control status for AD units. The A²C² element informs the G3 of conflicts which cannot be resolved at division level or through coordination with the corps A²C² element.

Rear CP

The rear CP does not have an A²C² element. The rear CP G3 operations cell responds to airspace conflicts as required. The rear CP G3 operations cell coordinates with the A²C² element in the main CP which plans, coordinates, and monitors A²C² for rear operations.

During rear operations, tactical changes may require changes to airspace control in the rear. A Level III response to a rear area threat primarily

affects LLTRs, SAAFRs, and other air corridors that transit through the rear.

Division A²C² Operations

Figure 5-28 shows items of information that each A²C² staff element requires to perform its functions. The staff elements using this information are shown by duty position.

In the forward AO where the division conducts close and deep operations, enemy actions may determine airspace use requirements. Division and corps aviation units maneuver over the battlefield, operating below the coordinating altitude and using terrain flight and standardized movement techniques. Attack helicopter battalions, air cavalry troops, and aviation companies in air assaults conduct combat operations as a unit. They respond to the tactical directives of an aviation C² system. As such, policy and procedures concerning air traffic management, identification of airspace users, and flight following differ from those for aircraft operating in the division and corps rear areas or COMMZ, or in a

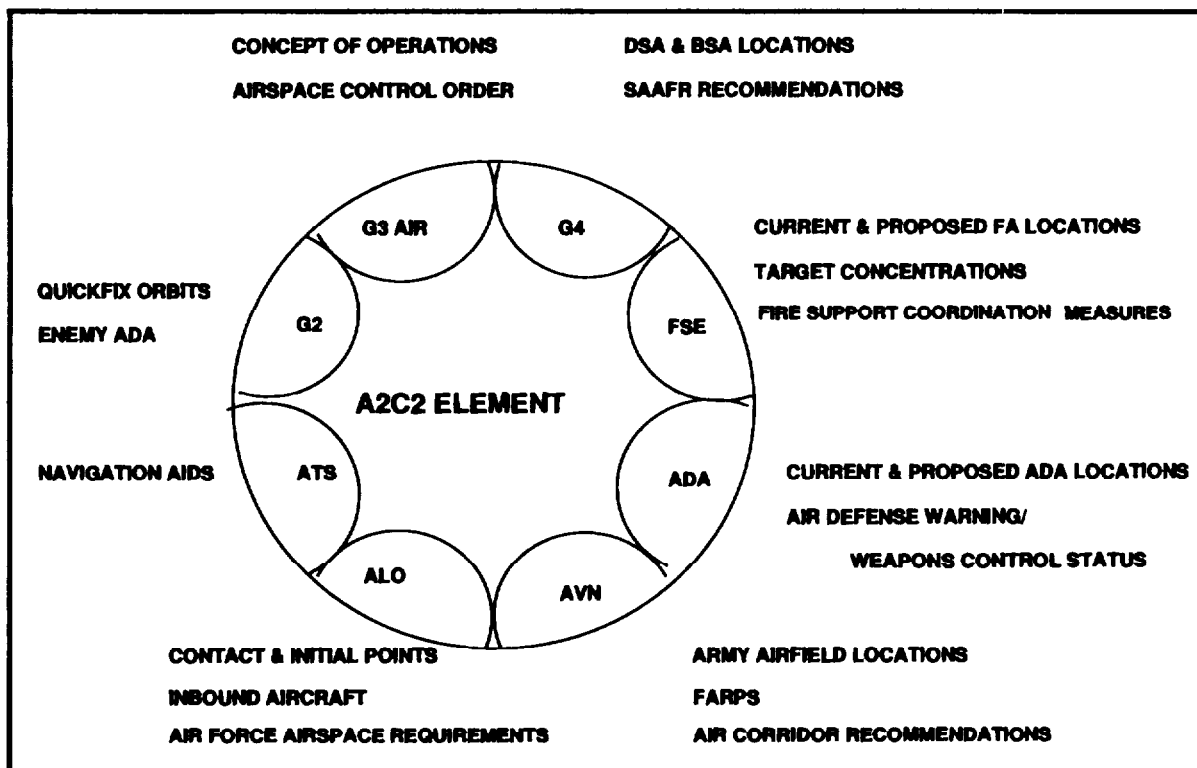

Figure 5-28. A²C² staff information requirements

controlled airspace. Aviation elements of corps and EAC normally conduct CSS missions as small elements or individual flights. As such, they operate under established procedural control rather than under their parent C² system. When operating in the MBA, these aircraft coordinate with the unit over which they are transiting.

Fire Support

Fires from mortars, cannon and rocket artillery, and missiles pose hazards to friendly aircraft activities. The highest probability of conflict between aircraft and surface-to-surface indirect fire occurs at relatively low altitudes in the immediate vicinity of firing units and target impact areas.

To reduce potential conflicts between surface-to-surface indirect fires and aircraft, the FSE provides firing battery locations and FS plans and activities to the A²C² element. The A²C² element disseminates this information to all aviation, ATS, and TACAIR elements. The FSE disseminates airspace control measures to firing units for establishing airspace coordination areas. Additionally, the interface between the FSE and the A²C² element ensures they coordinate planned artillery fires and UAVs with air operations and planned air activities with ground operations. This is essential to deconflict fires, air operations, and ground operations.

Air Defense Artillery

In forward area air defense (FAAD), the primary goal of airspace control is to avoid engaging friendly aircraft while imposing as few constraints as possible on both aircraft and FAAD systems. Achieving this goal involves developing procedures for FAAD and aircraft as well as a C² system to support timely dissemination of information.

The ADA representative in the A²C² element provides the location and coverage of organic and supporting AD units for use by the A²C² element to determine, coordinate, and recommend airspace control measures to the division commander and corps A²C² element. He disseminates active and on-call airspace control measures to the air battle management operations center (ABMOC) in the division ADA battalion. The

ABMOC issues the required instruction to affected ADA units.

Army Aviation

The Army aviation representative to the A²C² element provides locations of Army airfields, forward operating bases, and FARPs. He determines, coordinates, and recommends SAAFRs and air corridors to the division commander for approval. He disseminates A²C² information from the corps and brigade S3 airmen to the aviation brigade as well as to supporting medical evacuation (MEDEVAC) units.

Air Liaison Officer

The ALO provides locations of contact points and initial points to the A²C² element. He also provides times of preplanned or immediate CAS missions for use by the A²C² element to deconflict airspace use. The ALO also provides technical advice on employing aircraft and ensures ACA-approved airspace control measures are displayed on the A²C² map and incorporated in A²C² planning and coordination.

Air Traffic Service LO

The ATS LO representative provides A²C² elements with current status of flight coordination centers (FCCs), navigational aids (NAVAIDs), and ATS terminal support at airfields or LZs. The ATS LO ensures critical changes in airspace information affecting Army aircraft operating in the DRA are transmitted to aircraft through the FCCs.

G2 Section

The G2 representative provides the A²C² element with weather data and known and suspected locations of enemy units and air defense. This aids in planning and coordinating airspace control measures.

G4 Section

The G4 section provides the A²C² element locations of forward support battalions (FSBs) and bases in the division rear. The A²C² element uses the information to plan, determine, and coordinate SAAFRs in the division's AO. The G4 also informs the A²C² of air resupply missions for incorporation in the overall A²C² mission.

A²C² Planning

Plans and associated control measures for A²C² should be limited to those necessary to ensure conformity with the tactical plan and aircraft safety. They should make maximum use of procedural control measures. The scheme of maneuver and commander's intent determine and govern their design.

Planning will be as detailed as the situation and time allows. The urgency of the situation and time available will dictate whether to produce an A²C² annex. It should include only information which clarifies or amplifies what is in the unit SOPs, or specifies actions and procedures necessary to synchronize airspace use. In many situations, the fast-paced and dynamic tempo of combat operations may cause the A²C² staff to use an A²C² overlay and to issue verbal directives to subordinate forces.

The use of the field SOPs, airspace control orders, and airspace control plan standardizes procedures, reduces the amount of coordination, and provides implementing instructions. The need for an A²C² annex is thus minimized in many situations.

A²C² in Battle

Once the battle is in progress, the A²C² element at the main CP continues to monitor subordinate and parent units and modify plans as required. Effective coordination, rapid exchange of information, timely decision making, and rapid issuance of orders promote agility and initiative.

A²C² actions during the battle are the same as those performed during the planning phase. During the battle, emphasis is on—

- Anticipating and reacting to changes in the tactical situation.
 - Anticipating future requirements based on the progress of the battle.
- Ž Facilitating the ability of the commander to influence the battle with air assets. This means identifying potential airspace conflicts and taking immediate action to resolve them.

Organization of the A²C² system enhances coordination and exchange of information and permits the A²C² element to respond to changing requirements. Electronic communications and

messengers disseminate information, airspace control orders, and requests for special restrictive measures.

Airspace use and information displays maintained by the A²C² element include an airspace utilization and situation map and status boards and charts. Information is keyed to the CCIR. Matters pertaining to airspace use, or requirements of forces for airspace use, must receive prompt attention by the A²C² element and the current operations cell. Because commanders can employ air assets with a relatively short lead time, coordinating and integrating airspace requirements with the ongoing ground battle requires immediate attention. Current operations actions are also required when—

- Ž Conflicts develop in the DRA.
- Ž Corps directs a specific operation such as a deep operation.
- Ž Changes to the corps OPORD affecting the use or uses of airspace are a response to the tactical situation.
- Ž Conflicts cannot be resolved at a lower echelon.

The division A²C² element maintains data on ATS facilities, current and planned restrictive measures, and special joint use requirements. It recommends solutions to the G3 for conflicts that command guidance, orders, and SOPs cannot resolve. The division A²C² element also maintains data on the AD situation for use by other TOC elements. The G2 and AD channels provide data on hostile air activity to the A²C² element in the main CP. The A²C² element assists the commander by making recommendations concerning the impact the ADA weapons control status will have on air operations.

The supporting ATS unit and the A²C² element develop plans for ATS assistance to aircraft within the AO and to units conducting tactical operations. The ATS units operate under control of the G3. The ATS unit supporting the division is linked with the A²C² system, the host nation ATS, and the TACS. The ATS system supports aircraft of other units and component forces operating in the division AO. It also supports aviation brigade units conducting tactical operations, and is the interface between aircraft in flight and the A²C² element at the main CP.

ELECTRONIC WARFARE

Electronic warfare is the means through which the division commander protects his own electronic systems while attacking those of the enemy. It exploits, disrupts, and deceives the enemy system. It also protects friendly use of communications and noncommunications systems. This enhances the agility and initiative of the division, while limiting that of the enemy. The three functions of EW are—

- Electronic support measures (ESM).
- Electronic countermeasures (ECM).
- Electronic counter-counter measures (ECCM).

Electronic support measures are an intelligence-producing function to support ECM; ECM is a nonlethal attack means; and ECCM is an element of force protection. Electronic warfare may be offensive or defensive, is an essential element of combat power, and occurs during both offensive and defensive operations.

Electronic support measures and ECM are offensive components of EW. Electronic support measures search for, intercept, locate, and identify sources of radiated electromagnetic energy. They produce combat information for ECM, fire, maneuver, or threat avoidance. Electronic countermeasures prevent or reduce the enemy's effective use of electronic systems through jamming and electronic deception.

Electronic counter-countermeasures are the defensive portion of EW. They protect the friendly use of the electromagnetic spectrum and location of critical installations and systems. They consist of anti-ESM and anti-ECM. Anti-ESM prevents the enemy from intercepting, locating, and identifying friendly electronic systems. Anti-ECM precludes jamming or electronic deception of friendly forces.

Roles and Relationships

The G3 integrates and synchronizes EW into division operations. The EW staff officer, located in the FSE, is responsible to the G3 for planning and coordinating EW. He is specifically responsible for planning and coordinating ECM. He coordinates ESM requirements with G2 operations and ECCM requirements with the ADSO. He coordinates electronic deception and

integrates it into the deception plan. He is responsible for preparing both the EW estimate and EW annex to the division OPORD.

The G2 has staff responsibility for conduct of ESM. The G2 operations plans, coordinates, and integrates ESM in division operations. He coordinates ESM requirements with the EW staff officer and the TCAE of the MI battalion.

The SIGINT/EW officer in the ASPS conducts the EPB in coordination with both G2 operations and the TCAE. He also coordinates guarded frequencies with the EW staff officer to preclude their jamming.

The TCAE maintains the status of EW assets, collects technical data in support of EW, and assesses the effectiveness of division EW operations. The TCAE also conducts the mission management of EW assets.

The division signal officer is responsible for ECCM. The ADSO, located at the main CP, plans, coordinates, and integrates ECCM in division operations. He coordinates with the EW staff officer, G2 operations, and G3 operations to determine and disseminate taboo and protected frequencies and identify negative effects of ECM on division operations.

The division FSCoord in the FSE integrates ECM into the division FS plan. He coordinates with the EW staff officer to ensure ECM use is consistent with the division commander's concept and intent for fire support and the capabilities and availability of ECM assets.

Planning Considerations

The EW staff officer, G2 operations, ASPS, TCAE, and ADSO consider EW priorities as they plan and coordinate EW in support of division operations. Priorities include protection of friendly C3 systems, attack of critical FS capabilities, degrading of (or locating for destruction) enemy critical AD elements, and disruption of his critical C3 links.

Planners must also consider the following. In ECM, they consider target link distances (distance between the enemy transmitter and receiver), distance between the jammer and enemy receiver, radio line of sight, antenna polarization, jammer power and enemy transmitter power,

bandwidth compatibility, and terrain, weather, and vegetation. In ESM, they must consider system accuracy and distance to the target. A minimum of three lines of bearing (LOBS) is required to accurately locate a target through direction finding. Planners must consider enemy capability to conduct electronic deception against the division. In ECCM planning, they must consider the protection inherent in the division communications equipment and procedures, enemy capabilities, and division capability to quickly locate and attack enemy jammers.

The G3, G2, and FSCoord coordinate the planning of division EW operations. Based on the division commander's planning guidance, the G2 recommends the task organization of IEW assets to the G3. This task organization incorporates support to division deep, close, and rear operations as well as to committed maneuver brigades. The task organization incorporates ESM support to situation and target development and to ECM, and ECM targeting according to the division's HPTL and attack guidance matrix. The ADSO conducts ECCM planning. Planning begins with identifying essential friendly emitters and sensitive communications to protect. Friendly electronic emitters, signatures, and profiles are evaluated based on their vulnerabilities to enemy radio electronic combat and SIGINT capabilities. ECCM are then planned to overcome these vulnerabilities.

The G2 integrates ESM planning in the overall IPB process. While both terrain and weather both impact on friendly and enemy use of the electromagnetic spectrum, ESM planning begins during the threat evaluation phase of the IPB process. The ASPS in the main CP conducts an EPB. This process identifies the electronic template of the enemy force, is part of the overall situation development, and is the initial step in developing ESM support requirements for ECM.

ESM assets confirm or deny the EPB. This supports development of situational, event, and decision support templates during the threat integration phase of the IPB process. The EW staff officer and the TCAE also use this information to identify and plan targets for attack by ECM.

Electronic countermeasures planning incorporates the results of IPB and EPB into the commander's concept and intent through the

targeting process. HPTs are identified for ECM. The staff officer identifies HPTs, and uses the HPTL, attack guidance matrix, and division synchronization matrix to plan the attack. He coordinates ECM taskings with the TCAE, FSE, G3 operations, and signal officer.

The EW staff officer coordinates with the TCAE to ensure assets are properly positioned and available to accomplish ECM taskings. He coordinates with the FSE to ensure ECM targets are valid and require attack. He coordinates with G3 operations to ensure ECM targets are attacked according to the synchronization matrix. He coordinates with the signal officer to ensure ECM targets are not on the protected, or guarded frequencies, list. This ensures ECM operations do not interfere with friendly operations or target frequencies that are providing significant intelligence.

The EW officer also coordinates with the G3 and ADSO in the main CP to plan EW support of deception operations. At division level, electronic deception consists primarily of manipulative or simulative electronic deception. Manipulative electronic deception alters the friendly electromagnetic profile or deliberately transmits false information. Simulative electronic deception simulates nonexistent units or capabilities or units and capabilities at false locations.

The ADSO conducts ECCM planning at the division level. Threat evaluation and integration during the IPB process indicate the enemy's capability to conduct radio electronic combat against the division. The ADSO, in coordination with the G3, determines critical friendly emitters to protect. He plans ECCM to protect them through assignment of taboo and guarded frequencies; frequency allocation; use of meaconing, intrusion, jamming and interference (MIJI) reports; terrain masking; and attack of enemy jammers.

Electronic warfare planning differs little between offensive and defensive operations. The primary difference is proximity of systems to the FLOT, Figure 5-29, page 5-56, and Figure 5-30, page 5-57, portray typical offensive and defensive EW arrays. In both the offense and defense, EW assets are employed as part of MI company teams and leapfrog from position to position to maintain coverage.

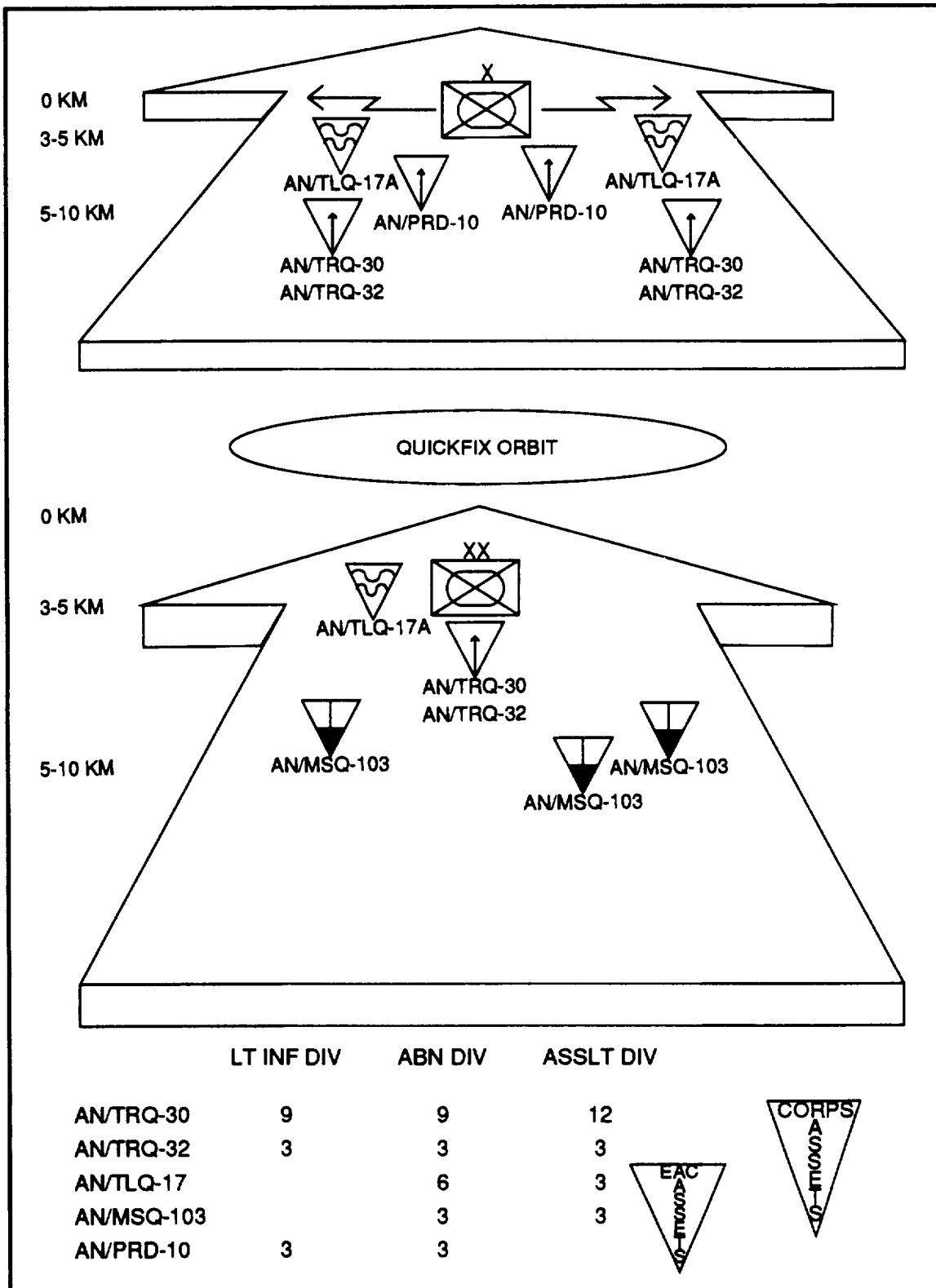

Figure 5-29. EW offensive array

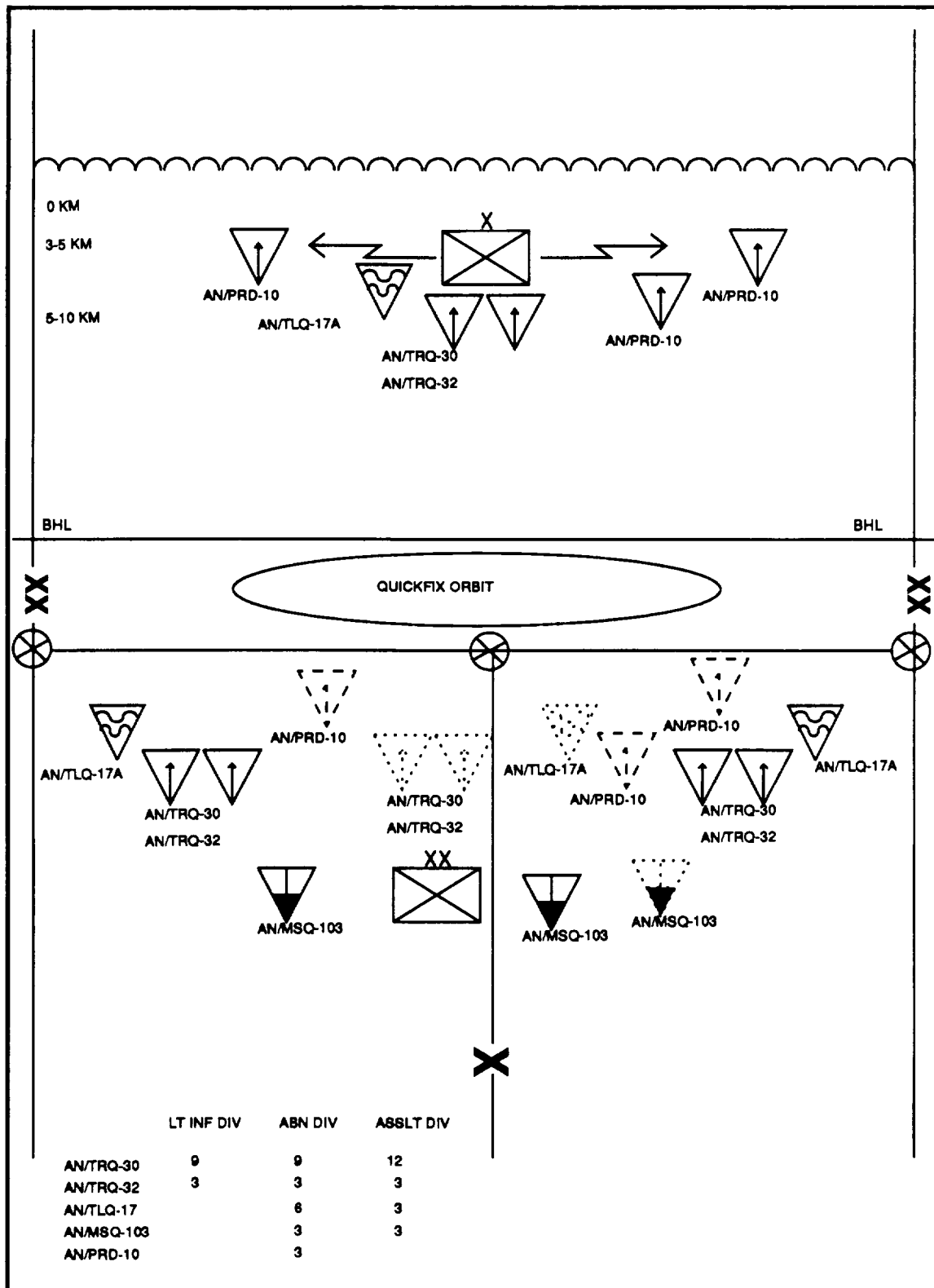

Figure 5-30. EW defensive array

An Example

The division receives a warning order and corps OPORD to conduct an attack as part of a corps operation. The G2 continues to update the IPB as part of the preparation for the attack. The IPB, and the division commander's restated mission and planning guidance, are the bases for developing the concept of operations and commander's intent.

During the IPB process, the ASPS developed an EPB which identified critical enemy communications and noncommunications emitters, capabilities, locations, and supporting technical data. The G3, G2, FSE, and signal officer integrate this information into the division OPORD.

The G2 identifies enemy units, locations, dispositions, and probable COAs through the use of ESM. He verifies them through other intelligence assets. This precludes the enemy from deceiving the division through electronic deception.

The G3, with the G2 and FSCoord, determines the HPTs and attack guidance which the commander approves. During the decide phase of the targeting process, the G3, with the EW staff officer, FSE chief, and G2, determines that the enemy division's C² system for FS and AD are HPTs. The G3 also determines ECM will be part of FS means during the attack. He provides this decision to the EW staff officer to plan and coordinate ECM with the G2, FSE, and signal officer.

The EW staff officer coordinates with the G2 ASPS and TCAE to ensure required technical data is available to support the ECM missions. If not, the EW staff officer ensures ESM collection tasks are planned and conducted to provide this data. He coordinates with the FSE to plan the ECM attack in conjunction with other FS assets. The EW staff officer also coordinates with the signal officer to ensure that frequencies to be jammed are not taboo, protected, or guarded and ECM will not impact negatively on friendly operations.

The G3 develops a deception plan during the development of the division's attack plan. The EW staff officer, with the battlefield deception element and ADSO, develops the electronic deception portion of this plan and includes it in the deception annex to the division OPORD. This plan

consists of simulative electronic deception to assist in the portrayal of the division main effort in a false location.

The ADSO coordinates with G2 ASPS and determines the enemy's capability to conduct EW against the division. He reviews the division and MSC CP locations to determine their susceptibility to jamming and recommends alternate locations for those that are high risk. He coordinates with the G2 and FSE chief to expeditiously locate enemy jammers and engage by lethal attack those having a significant impact on division operations.

The FSE chief and EW staff officer identify the timing and sequencing of ECM targets to maximize attack effectiveness by massing both lethal and nonlethal attack assets. The FSE provides the EW staff officer an execution matrix to assist him in the coordination, timing, and synchronization of ECM assets with the TCAE.

During the attack, the G3 ensures synchronization of EW with the overall plan. The EW staff officer monitors and informs the G3 of the status of EW assets and actions. He also monitors current operations and coordinates positioning and tasking of ECM assets with the TCAE. He ensures ECM assets are properly positioned to attack targets according to the scheme of maneuver and the FS plan.

The G2 ensures ESM assets are available and in position to support the situation and target development and provide ESM support to ECM. The ASPS EW and SIGINT officer coordinates requirements with the TCAE and G2 operations cell. The FSE chief coordinates with the EW staff officer. This ensures all ECM assets engage targets according to the execution matrix. The ADSO monitors the status of friendly communications. The intelligence system locates enemy jammers that are negatively affecting the division's communications and provides them as targets to the FSE for engagement by lethal attack.

DECEPTION OPERATIONS

Deception is an important combat multiplier. It enhances the conditions which allow the commander to effectively mass forces at decisive times and locations. It should be a consideration in every division operation.

The ultimate goal of division-level deception operations is to manipulate enemy behavior and create opportunities for exploitation. Battlefield deception enables the commander to conduct economy of force operations, mass at a decisive point, and conserve and protect the force. Well-planned and executed deceptions, not luck, achieve surprise and its benefits.

Planning Considerations

Deception operations cannot be planned independently of tactical operations. The primary consideration in any deception is the corps mission and deception plan. Deceptions, whenever possible, should be centralized. Like missions and OPODS, deception must be synchronized from the top down. Failure to do this can result in wasted combat power and possible disaster. Higher and, when necessary, adjacent headquarters should be aware of division deception operations. Failure to coordinate can damage other units' operations or deceptions.

A deception must be plausible. The enemy must believe the division's actions are in accordance with its doctrine and the division can do what the deception indicates. Enemy intelligence collection channels must be fed information in a coordinated redundant effort. The division may have to pass the same information repeatedly through multiple channels to ensure the enemy collects the deception. The enemy must see a picture consistent with our capabilities and his beliefs.

Deceptions should be adaptable and flexible. As the plan changes, the deception may also be forced to change. The division must portray the deception for as long as it is feasible and beneficial. For this to happen, the overall plan, including the deception, must have built-in flexibility.

Integration is vital to successful deceptions. A deception must not only be part of the overall plan, it must extend into the plan's every facet. That is, aside from being part of the operations, it must be part of the logistics, FS, AD, signal, and engineer portions as well.

The division can expect the enemy to know its norms. The enemy will seek to find where the division places class I, III, and V depots, for

example. He will look for medical treatment and maintenance facilities, and FS units. These signatures provide him a basis for true intent. Without full integration into all plans, the deception will quickly lose credibility.

The target of any deception is the enemy decision maker. He has the authority to react to the deception. It does no good to design elaborate deceptions if the enemy is incapable of either collecting, analyzing, or reacting to the information, or if the deception is contrary to normal operating procedures.

Feedback is important in any deception. Means to verify the deception must be established. The division's normal intelligence infrastructure or specially established means can normally accomplish this. It may not always be possible to verify the deception, and for this reason, all plans, including deception plans, must be flexible.

Finally, the division must consider cost of a deception in terms of resource expenditure. For a deception to appear real, the division must dedicate adequate resources. The cost depends on the type of deception (demonstration, display, feint, or ruse) and its objective. The division must also measure costs in risk and flexibility. For example, it may be very risky for the success of the division's main effort to rely solely on the success of a planned demonstration. Should the demonstration not produce the expected enemy reaction, it could cause the main effort to fail. Flexibility is built into the plan by using branches, sequels, or executable deceptions.

The goal of any deception is to cause the enemy to act contrary to his interests and beneficial to the division's. The division's goals are to—

- Condition the target's beliefs.
- Influence the target's actions by misleading him and persuading him to adopt a specific course of action.
- Benefit from his actions through surprise, superior combat power, and improved survivability.

The five components of battlefield deception are the objective, target, story, plan, and event. The objective is what the division wants the enemy to do. The target is the enemy decision

maker. The story is what the division portrays to the enemy. The plan is the concept of how the story is portrayed. Events are specific actions performed as part of the plan. Since deception is inherent in planning and concurrent with current operations, the division G3 has overall responsibility for deception (with support from other staff agencies).

If the intent is to induce the enemy to do something the division can exploit, the commander and staff must address deception early in the planning process. Deception designed after the division has developed, war-gamed, and decided on a COA is wasted. It becomes an afterthought, ill planned because of lack of time, and ill resourced because all division assets have been allocated in the war game of the chosen COA.

In providing his deception guidance, the division commander should consider—

- What he wants the enemy to do.
- How the division can best make the enemy do it.
- What forces and material will be dedicated to the effort.
- What enemy behavior is expected.
- How the division can benefit from that behavior.

These guidelines require the deception to do more than just alter or reinforce enemy perceptions. It must manipulate enemy behavior and then exploit it.

The staff uses this guidance to develop a deception plan or COA in the same manner as it develops and analyzes other COAs. The G2 provides normal input, identifying enemy weaknesses and vulnerabilities, and enemy collection assets that can detect the deception. Done properly, a deception should be part of a COA. Like any COA, deception development must involve the entire staff with OPSEC measures developed and implemented.

Operations Flexibility

Operations flexibility is a technique the division uses to plan and prepare for two or more related COAs, rather than optimizing one. This

inherently builds flexibility into the operation. It causes the enemy to become vulnerable to manipulation and exploitation. The division selects one COA for execution and another related COA for portrayal to the enemy. Both COAs (one shown and one hidden) seek to obtain a specific reaction. Thus, if the enemy reacts to the visible (deceptive) COA, the concealed COA will be able to exploit him.

Conversely, if the enemy rejects the visible COA, reacting instead to the concealed COA or yet another, the division may still be able to exploit him by executing the visible COA. The key to this type of deception is that no matter what the enemy does, whether he reacts to the deception or not, the commander still has an executable COA. This technique differs from a demonstration or a ruse, which normally lack any significant combat power and are not usable for exploitation.

The deception process relies greatly on signature management. Signature management is the use of—

• Deception assets (decoys, dummies, and signature replicating devices) to augment or mask signatures.

- OPSEC assets and techniques to diminish signatures.
- Real assets and techniques to augment or diminish COA signatures.

In short, it is the selective management of key activities to directly or indirectly control the enemy's behavior.

The division uses signature management to reduce the visibility of key activities associated with the COA it intends to execute (the COA it wants to hide). It does this through the judicious use of OPSEC techniques and assets and in the manner it conducts its real operations. For instance, a reserve force for the intended COA may go to radio silence or coordinate a passage of lines face to face. This may hide the existence and intent of the unit. An engineer unit might lay a deliberate minefield at night. Logistics supply points might be hidden in a built-up area. These techniques reduce signatures and avoid detection.

Simultaneously, key signatures associated with the deceptive COA are highlighted through more visible activities. For example, the reserve force mentioned above could support the deception COA. It could coordinate a passage of lines along a major avenue of approach via radio. Logistics supply points could be poorly camouflaged or even left out in the open. Dummy logistics assets, such as blow-up rubber 55-gallon drums, or empty ammunition crates, can augment the signature. The engineer unit may lay a hasty minefield during daylight hours with soldiers and equipment, or in some other manner designed for enemy detection.

In the end, operations flexibility gives the division commander an inherently deceptive OPLAN and enhances his ability to execute it on the battlefield. It requires the commander's guidance on deception early in the planning process. It requires a coordinated staff effort, including war gaming.

Deception Execution

All staff agencies, but especially the G2 and G3, must carefully control and monitor deception execution. For this purpose, the corps battlefield deception element can be extremely helpful.

The corps may attach members of the battlefield deception element to the division. They may operate as a team, split team, or single person configuration across the AO. They advise and assist units on the deception execution. They may also function as the eyes and ears for both the G3 and G2. They can assist the G3 in timely and proper execution of deception events. They may also help provide the G2 intelligence on enemy reactions to the deception.

At times, the corps battlefield deception element may assist the division by becoming a part of the deception. Resource availability within the division, or the lack thereof, may require the division to request it to provide people and assets to replicate C3 signatures. The corps battlefield deception element has the capability to do this; however, it should be used only as a last resort. Its primary responsibilities are planning,

monitoring, and assisting; its personnel and equipment assets are limited.

To properly evaluate deception activities, the division must determine their impact on the enemy. This requires reliable feedback, an important aspect of any deception. Without feedback, the division can never be confident the enemy decision maker is intentionally reacting to the deception in ways contrary to his better interest. The division G2 plays a major role in this regard.

The division obtains the necessary feedback in one of three ways. It can use its already established intelligence gathering infrastructure, or it can establish a special means with which to collect information about the deception. This involves using many of the same assets used routinely to collect intelligence, the difference being the focus of the effort. It can also use a combination of the two methods above. In any case, the division must obtain reliable feedback to determine if the deception is working or has been compromised, or if the plan requires adjustments to improve its effectiveness or plausibility.

The division may require only a reasonable assurance that intended signals reached the decision maker and had their intended effect. This will not always be possible to confirm. The division must rely on information available and knowledge of the enemy to determine his reaction to the deception. However, if the plan is flexible, the criticality of feedback is somewhat lessened. This is not to say feedback then becomes unimportant. It is always one of the most important aspects of deception.

The termination of a deception can be as critical as its execution. The concept of playing out the deception should be a double-edged sword for the enemy. The division should continue the deception for as long as possible with the intent of never allowing the enemy to know he has been deceived, or phase out the deception in such a manner that the enemy views it as a perfectly plausible activity. If the enemy discovers the deception for what it is, he may become the exploiter instead of the exploited. He may also review the signals he received throughout the operation and view them skeptically, reducing the division's ability to deceive him in future operations.

COUNTERFIRE

The enemy may employ fire support to create opportunities for maneuver forces to exploit. The division should establish conditions for decisive combat maneuver through destruction of the enemy's FS system.

Counterfire consists of fires targeted throughout the battlefield that attack the enemy's entire FS system. Counterfire assists the division to achieve and maintain agility and initiative. It gains freedom of action and protects the force. It also deprives the enemy of freedom of action.

The division commander must realize that counterfire is not solely the responsibility of the division artillery commander. Counterfire requires integration of intelligence, fire support, and maneuver. It is a concurrent operation the division commander and staff must coordinate and synchronize within the framework of the offensive or defensive mission.

Components of Counterfire

Counterfire may be proactive or reactive. Proactive counterfire is the detection and attack of enemy nonfiring, as well as firing, systems before they engage friendly forces. It is linked with the targeting effort. Reactive counterfire is, as the name implies, a response to the enemy's engagement of the division.

Proactive counterfire requires the intelligence system to identify, locate, and accurately target elements of the enemy FS system. The corps normally conducts the proactive portion of counterfire. It has the intelligence and attack systems to identify, locate, and attack the enemy's fire support before its commitment, arrival, and employment against the division. Still, the division may conduct proactive counterfire against enemy FS systems within range of organic and supporting intelligence and FS systems.

Reactive counterfire requires integration of intelligence, target acquisition, FS, maneuver, and C². The intelligence system must use the IPB to predict likely locations of enemy FS systems. Using this prediction, the division positions and tasks intelligence sensors and target acquisition

assets to confirm the IPB and provide target information. Fire support assets engage enemy FS systems on the basis of this information. Maneuver elements provide information from reconnaissance and surveillance. They also may engage enemy target acquisition assets located on or near the FLOT. The C² system provides the reporting network for counterfire and identifies priorities for protection of the force.

Roles and Relationships

Ž The division commander is responsible for counterfire throughout the division AOR. His counterfire responsibilities include—

- Developing, planning, and describing his vision, concept, and intent for counterfire within the total division mission.
- Segmenting the battlefield through maneuver boundaries or assignment of AORs. This delineates responsibilities for counterfire within the division zone.
- Prioritizing the counterfire effort within the division's zone.
- Allocating resources within the context of the overall division mission.
- Synchronizing the division counterfire effort.

The division has a more reactive counterfire focus than the corps. The division also requires greater emphasis on rapid execution of counterfire.

Within the division, key staff members for counterfire operations are the G2, G3, and DFSCoord. The G2 develops and updates the IPB, tasks sensors and units to acquire target information, and disseminates information to the G3 and FSE. The G3 integrates and prioritizes Counterfire into the concept of operations. He allocates resources in the context of the overall mission. The DFSCoord integrates Counterfire into the division's FS plan.

The engineer and G4 are also involved in the counterfire process. The engineer may be required to provide survivability support to the artillery. The G4 orchestrates class V support for the FS systems, including attack helicopters.

Planning Considerations

Division planning considerations for counterfire include—

- The corps Counterfire plan.
- Capabilities of friendly and enemy fire support.
- Capabilities of friendly and enemy target acquisition.
- Command and control capabilities.

Division must understand its role within the corps counterfire plan. The corps counterfire plan is defined through the corps commander's concept and intent. Corps FS and artillery support plans further define corps and division roles. Corps delineates responsibilities, establishes priorities, and allocates resources based on the corps mission and the part Counterfire plays in the mission.

Within the division, the first Counterfire consideration is the enemy's capabilities. The G2 provides this information as part of the IPB and targeting process. These considerations include the enemy's mission, and whether the division is facing the enemy main effort. Both impact on the division's counterfire requirements and plan. His considerations are not only enemy mortars and artillery, but also enemy electronic warfare, and fixed- and rotary-wing assets. He includes ranges, echelon, and types of artillery in the estimate. Less counterfire is required against towed artillery than against self-propelled artillery. Range and echelon affect not only the enemy's capability to engage the division in depth, but also where the enemy positions his artillery on the battlefield.

Munitions capabilities of the enemy FS system are also a consideration in the counterfire planning. Weapons that fire improved conventional munitions are a greater threat than those capable of firing only standard high explosive (HE) munitions.

The G3 and DFSCoord must consider the capabilities of friendly weapons systems. The corps 155-millimeter and corps 203-millimeter howitzers can fire 30 kilometers with RAP munitions. However, these munitions don't have the effectiveness of the dual-purpose improved conventional munitions (DPICMs). The DPICM's

maximum range is 18 kilometers for the 155-millimeter howitzer and 23 kilometers for the 203-millimeter howitzer. The MLRS is normally the Counterfire weapon of choice. It has a maximum range of 30 kilometers, but a minimum range of 8 kilometers. If it is positioned well forward to range deep into the enemy formation, it may not be capable of ranging counterfire targets on or near the FLOT.

Enemy target acquisition capabilities also impact the division's counterfire planning. The division must plan to attack and destroy enemy artillery reconnaissance elements and command OPs through an aggressive counter-reconnaissance effort. The division also must strictly employ and enforce ECCM to negate or limit enemy direction-finding capabilities. If the enemy artillery target acquisition threat is great, friendly artillery must move frequently to survive. The division must locate and destroy enemy counterfire radars to enhance survivability of mortars and artillery.

Similarly, the commander and staff must consider the division's target acquisition capabilities. These capabilities include the Q-36 Firefinder radar, IEW systems, UAVs, forward observers, and COLTS employed with the maneuver forces. Each of these provides a different degree of accuracy and speed of targeting data. The division must also consider threats to each of these. For example, operations against an enemy with a sophisticated EW capability require cueing guidance for counterfire radars to preclude their identification, location, and destruction.

The C² organization of friendly artillery is also a consideration. The division must decide whether to centralize or decentralize execution of counterfire by the artillery. Augmenting the division with a corps artillery and target acquisition detachment provides additional flexibility. Centralization facilitates massing of artillery and precludes duplication of effort. It also enhances use of counterfire radars, (See Figure 5-31, page 5-64.) However, centralization places a heavy burden on the headquarters responsible for executing artillery counterfire. If the division has a reinforcing corps FA brigade, it may be assigned to execute artillery-delivered counterfire (but the overall responsibility to

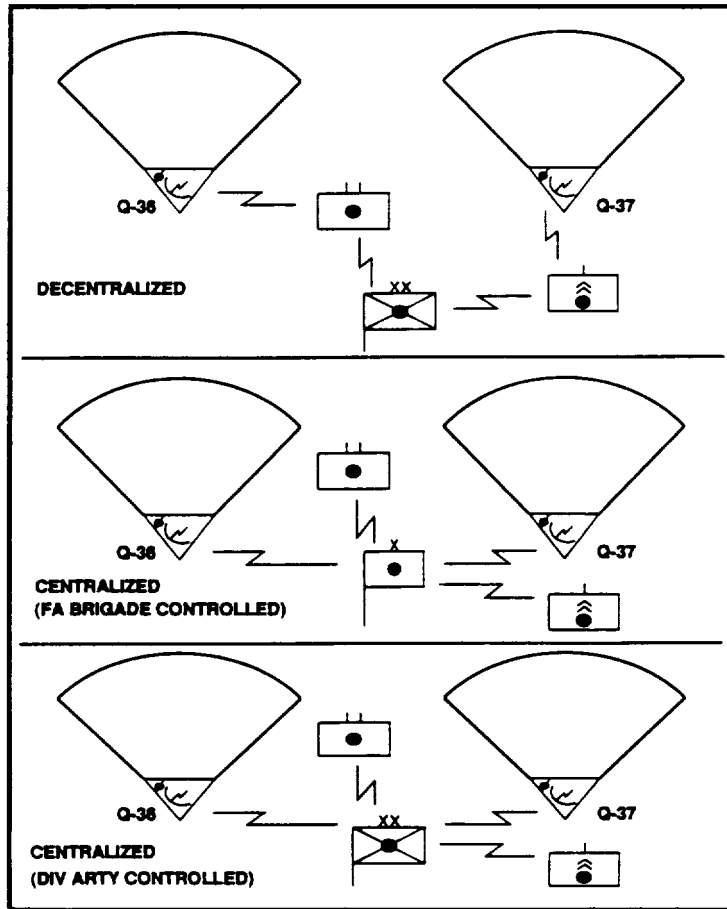

Figure 5-31. Radar command and control organization

execute the division's counterfire efforts still remains with the DIVARTY commander). This allows the corps FA brigade to focus on counterfire while the DIVARTY headquarters focuses on artillery support to committed forces.

Techniques

The corps should delineate counterfire responsibilities between the corps and division. This allows each echelon to focus on a specific area of the battlefield and prevents duplication of effort.

counterfire planning begins with the targeting process during COA development and war gaming. The targeting cell identifies high-value targets and refines them into HPTs for the division. It recommends what targets to attack, how to detect and engage them, and how to determine the results (battle damage assessment). The

targeting cell does this as part of the total targeting process of the division and not as a separate action.

Generally, the division conducts reactive counterfire against enemy mortars and artillery. The corps normally engages enemy artillery and other FS assets. However, maneuver brigades may have counterfire responsibility against mortars and artillery of committed regiments, while the division conducts counterfire against enemy division artillery.

The commander prioritizes counterfire targets within the division zone. Normally, enemy fire support facing the division's main attack or main defensive effort will receive the priority for counterfire. However, when the division employs a unit in an economy of force role, it may receive priority for counterfire.

Once the commander decides what to attack with counterfire his staff can plan how targets will be detected. Again, the IPB process is the first step. Using the situational and event templates from the IPB process, the G2 and FSE focus IEW sensors and target acquisition assets on likely positions of enemy tire support. The division may use the engineer terrain team or TerraBase software to develop visibility diagrams. These are used to position observers or assistant fire support officers (AFSOs) to observe enemy artillery positions and request fire against them.

The staff may use these same templates and diagrams to position and orient counterfire radars and GSR. The counterfire radars identify and provide locations of mortars, artillery, and rocket units as they are firing. Call for tire zones should be established in the counterfire radars around likely enemy firing positions. Ground surveillance radars may provide combat information on enemy firing units occupying likely firing positions. They also may provide a degree of battle damage assessment indicating units are displacing after a likely firing position has been engaged. They also may cue other target acquisition assets such as the AFSO.

Similarly, with direction finding, ESM assets may locate key FS headquarters for lethal attack or jamming. ESM assets also may be used to identify and locate artillery reconnaissance elements or command OPs as part of the division counterreconnaissance effort.

The division uses a variety of techniques to execute counterfire. One, the counterfire program, is used when there is little movement of enemy fire support assets and sufficient time available to identify, locate, and target them. It is used to disrupt enemy fire support systems at critical times, such as during a counterattack or a penetration.

Another technique is strictly reactive counterfire. This involves attacking enemy FS assets during or immediately following enemy engagement of friendly forces. A cueing agent normally initiates this technique. He directs the counterfire radar to radiate, acquire the target, and transmit a fire mission to its reporting headquarters.

The use of counterfire radars requires several decisions. First, the division examines the threat to decide if radars will operate in a continuous or command-cued manner. If threat of acquiring the radars is low, then the commander may direct continuous cueing. If the threat is high, the division normally employs command cueing. Command cueing requires cueing agents to direct the radar to radiate. These agents are normally battalion or brigade FS officers, but may include FIST chiefs or even individual forward observers.

The controlling headquarters assigns zones of search to individual radars. Each radar may establish up to nine zones of search. These zones are—

- Critical friendly zones (CFZs).
- Call for tire zones (CFFZs).
- Artillery target intelligence zones (ATIZs).
- Sensor zones.

The CFZs are established around the highest priority friendly locations. Typical CFZs include maneuver assembly areas, headquarters, and other troop concentrations. The CFZ provides the most responsive priority of fires from radars.

The CFFZs designate locations beyond the FLOT that are likely enemy artillery or mortar positions. Enemy fires from a CFFZ result in the second most responsive priority of fires from the radar.

The ATIZs allow the commander to monitor a likely enemy firing position, but give higher priority to other locations. Enemy fires from within an ATIZ may be evaluated for attack, but do not automatically generate a fire mission as do the CFZ and CFFZ.

Sensor zones designate areas from which the commander does not want to attack targets. This zone is often used to prevent overlap and duplication.

Counterfire radars may be digitally linked to one of several artillery headquarters. One technique is to assign a Q-36 radar to each DS artillery battalion. This provides the maneuver brigade commander a reactive counterfire capability he would not otherwise have. It allows the brigade commander to orient the radar and

establish zones of search that best support his concept of operations. Concurrently, the two Q-37 radars may be linked to DIVARTY headquarters to provide reactive target acquisition at division level. The division may use this technique if maneuver brigades have the counterfire responsibility against regimental artillery and mortars.

A second technique is to have all counterfire radars report to DIVARTY headquarters. This allows DIVARTY to centrally command and control radars and artillery counterfire. It also enables DIVARTY to maintain continuous coverage of the division sector by leapfrogging counterfire radars. However, the complexity of this technique may cause DIVARTY to lose visibility of other functions. Additionally, if the division does not have sufficient GS or GS-reinforcing artillery, then radars may quickly overload available artillery at division level.

Counterfire radars may report to a reinforcing artillery brigade, if one is assigned. This allows DIVARTY to monitor counterfire execution while focusing on its other functions. Even if the reinforcing artillery brigade has the

counterfire mission, the DIVARTY commander maintains overall responsibility. He augments the reinforcing FA brigade with assets from the target acquisition battery to enable the FA brigade to accomplish this mission effectively.

The division may employ maneuver forces against enemy FS systems. This may include use of small maneuver elements to engage reconnaissance, surveillance, and target acquisition elements (such as artillery reconnaissance or command OPS). The division may employ attack helicopters against artillery groupings at regiment, division, or army level.

The division may employ a joint attack of artillery. This is similar to a JAAT but is targeted specifically against enemy artillery.

The division may employ a mix of these techniques. (See Figure 5-32.) Ground maneuver forces may attack target acquisition elements while EW assets jam key fire support nets. The division may use mortars against target acquisition assets or fire direction centers (FDCs) while artillery, attack helicopters, and CAS aircraft engage artillery.

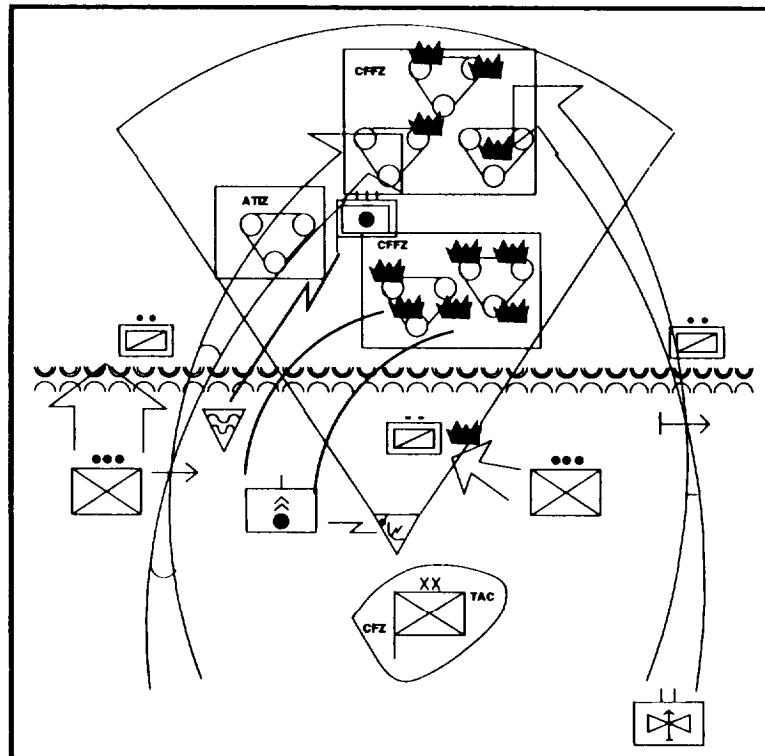

Figure 5-32. counterfire attack

CHAPTER 6

OPERATIONS OTHER THAN WAR

FM 100-5, FM 100-20, and FM 100-19 are the doctrinal basis for operations other than war. Infantry divisions conduct operations other than war in peacetime, conflict, or war. Many division tactics and techniques for war apply to operations other than war. Many of the same principles apply, modified to meet the particular environment in which they are employed. The infantry division focuses and trains for combat operations. However, it maintains the versatility to shift focus, tailor forces, and move from one mission to another rapidly in operations other than war. This chapter provides some examples of division operations in operations other than war.

FUNDAMENTALS

Peacetime activities are predominantly non-hostile and are characterized by the benign use of military forces. These operations contribute to US national interests and help keep day-to-day tensions below the threshold of conflict. In *conflict*, the use of force is in direct response to a physical enemy threat. Operations other than war are characterized by short-term, rapid projection or employment of forces and detailed ROE. The desired end state for the division is to decisively accomplish its mission and either redeploy or transition into peacetime activities. However, a division may conduct operations other than war in a wartime environment. *War* requires the maximum application of combat power against the enemy's center of gravity. Generally, infantry division tactics and techniques in conflict and war may differ only in C² relationships and ROE constraints.

The infantry division conducts *contingency operations*—a rapid response to a foreign or domestic crisis—as the initial part of the force projection national military strategy. Typically, these operations are conducted in eight stages:

Ž Mobilization (as needed).

Ž Predeployment activity.

- Deployment.
- Entry operations.
- Operations.
- Postconflict operations.
- Redeployment and no constitution.
- Demobilization (as needed).

The division plans and considers all stages; however, this chapter focuses on *deployment*, *entry*, *decisive operations* (specifically, in peacetime), and *restoration*. Tactics and techniques in conflict are covered in other chapters. The division plans for mobilization according to the Army mobilization and operations planning system (AMOPES). Mobilization planning generally centers on the integration of slice and roundout reserve component units such as civil affairs attachments and rear operations centers (ROCs).

To conduct contingency operations, a JTF is normally formed under a combatant or specified command. During peacetime operations, division forces can expect to be subordinate to other US government agencies. The division should ask for and receive augmentation for these missions.

If the division is designated as an Army forces (ARFOR) headquarters, it must be augmented by corps and the Army service component command. This augmentation package includes deployable personnel and equipment, and units:

Ž Logistics planners—joint operations planning system (JOPES), G3 air, and G4 and DTO.

Ž Communications package.

- MI brigade IEW assets.
- Operational planners and LOs.
- Special operations C² element.

Ž Special CS and CSS Army units required for nontactical missions.

Augmentation must be completely ready to deploy OCONUS when they report to the division.

The Army service component of the theater is responsible for providing logistics support to the

ARFOR. Terms of reference (TOR) on theater support requirements must be agreed upon. (See Figure 6-1.)

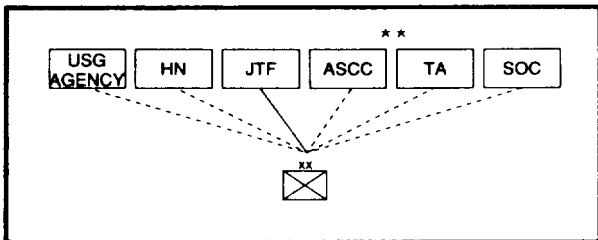

Figure 6-1. Theater command relationships

Usually, division conducts operational planning for all eight stages of force projection operations. Based on the factors of METT-T plus P (political factors), the division may deploy as a whole or be task-organized as a smaller force to accomplish a specific mission.

Divisions may provide forces and equipment to support operations other than war. Such actions include—

- Ž Nation assistance.
 - Peacekeeping (peace enforcement).
 - Security assistance.
 - Humanitarian assistance and disaster relief.
 - Support to counterdrug operations.
 - Support to domestic civil authority.
 - Postconflict operations.
- Ž Shows of force.
 - Noncombatant evacuation operations (NE O).
 - Attacks and raids.
 - Base defenses.
 - Support to insurgency or counterinsurgency.
 - Combatting terrorism.

PEACETIME ACTIVITIES

Division forces may deploy to support peacetime activities as individual units, or as task forces. The division may deploy as a whole during large-scale disaster relief efforts and the restoration phase of a combat operation. Forces are task-organized for a specific activity, normally as a component of an interagency, unified, joint, or

combined operation, A division headquarters element may be deployed to provide C² interface with the JTF, other US government agencies, or host nation (HN) authorities, even when a single brigade task force is deployed.

The infantry division possesses skills and assets which can effectively support peacetime activities. The infantry division can provide forces and equipment for—

Ž Combined command post exercises (CPXs) and field training exercises (FTXs).

- Engineer support and assistance.
- Health service support.
- Surveillance, communications, and airlift support to counterdrug operations.
- Peace enforcement.
- Ž Disaster relief and humanitarian assistance operations.

Operational Planning

While peacetime activities vary, division-level planning consists of four basic components:

- Mission analysis.
- Task organization.
- Logistics support.
- Ž Command, control, and communications.

Additionally, in peacetime activities, force protection and legal considerations will be important.

Mission Analysis

Although combat actions differ significantly from peacetime activities, the process for tactical decision making is similar. Specific mission analysis elements are facts, assumptions, analysis of higher mission and intent, and commander's guidance, (See FM 101-5.)

Facts. The division staff provides the commander pertinent facts. The G1 personnel estimate includes—

- Ž Unit strength and statistics of low-density MOSS that may be critical to this particular mission.
- Ž Preparation for overseas movement (POM) status of the division.

- Language-specific requirements and numbers of language-qualified personnel.

The SJA obtains the JTF or corps ROE and adapts them for use by division forces. Additionally, the SJA advises commanders on *posse comitatus* limitations and Title X restrictions on use of forces.

The G2 prepares a detailed and innovative IPB for the AO. This includes—

- Terrain analysis. A detailed analysis of key terrain, transportation networks (trafflcability and location), built-up areas, water, serviceable airfields, and possible LZs and DZs.
- Weather. Climatic and environmental conditions for a region can affect the mission. For example, hot, humid areas may require the acclimatization of soldiers.

Ž Political, social, economic factors. Peacetime activities have high political visibility. The end state of peacetime military activities cannot exclude political, social, and economic factors. These factors include the receptiveness of the host nation population to US forces, sources of political instability, ongoing insurgences, cultural sensitivities, and standard of living.

Ž Threat. The G2 identifies known threat activities and capabilities which could affect operations and summarizes recent and present threat activities that may indicate future actions. In some cases, the “threat” may not be “enemy personnel.”

Under normal circumstances, the G3 coordinates with the Army service component command of the gaining combatant command or US government agency (USG) to determine the scope of the operation and its level of support, funding, and C² relationships. The G3 also begins to plan and coordinate airlift, sealift, ground transport, and any specialized training which may be required with other USG agencies (that is, forest fire fighting or environmental cleanup). The G3 uses current unit status reports and METLs to determine units capable of conducting the operations.

The G4 provides the logistics status. The G4 compiles detailed estimates for all classes of supply and equipment. He determines what combat prescribed load lists are critical and increases quantities. The G4 estimates the amount of

support needed from the Army service component command to support the peacetime activity. The G4 also plans for redundancy of critical equipment to offset decreased repair and supply capability.

The *contracting officer* works closely with the G4 and the DISCOM commander throughout the planning process to determine what requirements need to be contracted prior to and during deployment. Additionally, the contracting officer determines contracting procedures in the assigned AO.

If operations are to be conducted in another country, the G5 reviews regional studies of AOs and, through the Army component command staff, coordinates with active and CAPSTONE CA and PSYOP units for that theater. The CA and PSYOP assets are critically needed during the predeployment phase to assist in planning. The G5 also examines needs assessments conducted for the AO to see what actually must be done. The G5 identifies the HN agency responsible for the operation, the level of HN participation, and points of contact within the HN government.

Assumptions. Having identified the facts available, the division staff develops assumptions needed to replace necessary, but missing, facts and facilitate planning. Assumptions developed during the initial planning may include—

- Availability and type of transportation assets (ground, sea, air).

Ž Force protection requirements.

- Training requirements.
- SOF participation.
- Security assistance organization (SAO) role.
- Use of reserve component forces.
- Other USG agencies’ roles.
- Lodgment sites and responsibilities.
- Host nation requirements and expectations (OCONUS).

Ž Funding.

Ž Special equipment requirements.

Analysis of Mission and Intent. Once tasked to support OCONUS peacetime activities,

the division staff analyzes the theater strategy, campaign plans, and concept plans (CONPLANS) of the gaining combatant command. The theater strategy articulates the CINC's vision for his theater. In most cases, it provides guidance, direction, and opportunities for peacetime activities in general terms of ends, ways, and means. Campaign plans and CONPLANS identify theater objectives, sustainment concept, needed resources, and specified and implied tasks. Supporting plans developed by the Army service component command provide more definitive guidance on essential tasks.

Support to US civil authorities, other than counterdrug operations, is usually a crisis response. In either case, USG agencies have the lead in planning and employing division assets. Divisions will be tasked on relatively short notice to support USG agency operations such as disaster relief. Divisions normally initiate direct coordination with USG agencies (such as, Federal Emergency Management Agency (FEMA), US Forestry Service, or US Coast Guard) to analyze their plans and guidance. In counterdrug operations, divisions may be tasked to support the Drug Enforcement Agency (DEA), US customs, and local law enforcement agency operations. In most cases, the division has sufficient time to coordinate with the regional CINC through the Army service component command, and the regional counterdrug JTF which coordinates military support to ground drug law enforcement agencies.

Commander's Guidance. Commander's guidance can be the most critical element of mission analysis during time of crisis and short notice warning, such as disaster relief and postconflict operations. The commander issues guidance on task organization, logistics support, and C³ arrangements.

Task Organization

Mission, funding, available lift, in-theater support, and political factors drive task organization. The division task organizes forces to be as self-contained as possible. The task force should have sufficient assets to accomplish the mission; sustain itself: provide air, land, and water transportation; and communicate with higher headquarters and home station. In most cases, a battalion or brigade task force will consist of

forces drawn from the whole division. A sample task organization for a nation assistance or postconflict operation is shown in Figure 6-2, Significant M/S requirements are common during these types of operations. Based on METT-T, the light division will normally require echelon above division (EAD) engineer augmentation to support its M/S operations and augment the capabilities of its organic engineers.

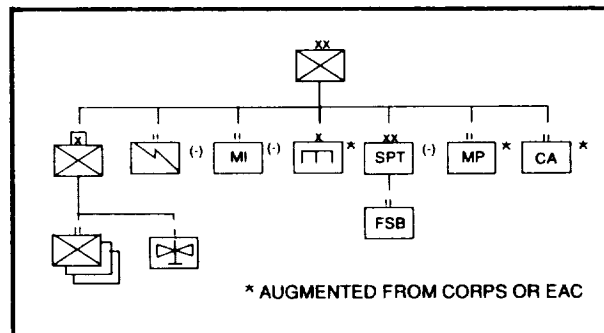

Figure 6.2. Sample task organization

The task force should be structured to interface with existing operational and logistics structures whether it is a JTF, in in-theater Army service component, or a USG agency.

In many cases, a brigade or battalion task force (with a brigade CP) will be sufficient to accomplish peacetime activities. However, large postconflict operations or contingency operations to restore reasonable order prior to conducting humanitarian assistance may require division-sized forces.

It is critical for G3 operations to define C² relationships for each developed supporting task organization. Maintenance and accountability of task organizations and unit C² relationships significantly impact on the accuracy of personnel accounting and strength reporting, replacement operations, and postal operations. Command and control relationships are established through command relationships (organic, assigned, attached, or OPCON) and assignment of tactical missions (direct support, reinforcing, GS reinforcing, or GS), "OPCON" or "attached" should be printed to the right of every unit not listed with its parent (assigned) unit of organization. OPCON unit strength is reported by the parent (assigned or losing) unit. Attached unit strength is the responsibility of the gaining commander or

S1. Decisions to “OPCON” or “attach” any DS or GS unit should be annotated.

Logistics Support

Logistics support of peacetime activities may involve providing on-hand and contracted materiel and supplies to both US and HN forces and agencies. It also can involve developing logistics systems and infrastructures and procedures for HN logistics personnel.

Once a division is given a mission, the G4 begins to plan for logistics support packages. He develops a concept for support and uses experienced logistics staff officers to ensure that the logistics system works smoothly. A DISCOM forward command post (DFCP) may be required. The DFCP is a rapid deployment logistics C² cell. It can be tailored to operate in any type of contingency. It is transportable in two C-141B sorties and provides the resources necessary for the immediate logistics C² of division or brigade task force operations. The DFCP can operate from three SICPS and four to eight vehicles (HMMWVs), but should be sited in buildings whenever possible. In most cases the DFCP will follow the division assault command post, and the division assault force. The composition of the DFCP varies; it may expand or contract in size, depending on the availability of strategic lift and the factors of METT-T. The DFCP should be headed by the DISCOM commander, S3, or division materiel management officer (DMMO) and normally comprises 26 personnel in these sections:

- CSS planning and operations.
- Movement control.
- Material management (general supply, class I, water, II, III, IV, and VIII supplies).
- Ammunition management.
- Maintenance management.
- Class IX repair parts.
- HSS operations and casualty evacuation.
- LOS (as required).

Once the total deployment of the division is complete, DFCP personnel transition back to the DISCOM and rear command post and assume their normal functions.

The DFCP’s primary mission is to rapidly establish and provide logistics C² interface between the FSBs and the corps support units or host nation located in the AOs.

The DFCP translates current developments into future requirements beyond 48 to 72 hours. Requirements identified by the FSBs are passed to the DFCP which in turn coordinates with the corps support units or host nation to ensure availability and distribution. The corps units or host nation will then supply the transportation assets necessary to throughout supplies to the BS. The DFCP can also assist support battalions by requesting additional support assets to augment the FSB.

During CONUS peacetime activities, the DFCP can be used to establish logistics LOC and support and liaison with sister services and other USG and local agencies. The 7th Infantry Division (Light) successfully used the DFCP during Operation GARDEN PLOT (federal response to Los Angeles riots) in May 1992. During this operation, the DFCP deployed as part of the ARFOR to the Joint Task Force Los Angeles (JTF-LA). As primary logistics support element of JTF-LA, the DFCP established liaison and coordinated with the 3d Marine Amphibious Wing, 40th ID (ANG), 2d Brigade TF (71D(L)), and JTF-LA. Additionally, the DFCP coordinated local civilian logistics support for shelter and food.

Mission Requirements. The mission dictates the level and type of support needed. Logistics planners consider essential tasks to be accomplished by the task force, terrain, and degree of interagency and HN support. Peacetime activities in austere environments may require special class I, such as use of a reverse osmosis water purification unit (ROWPU) or bottled water. A class III storage capability may be needed to support fuel requirements (air and ground) in isolated areas.

Available Theater Support. Maximum reliance on theater support is critical to long-term sustainment of forces. Early coordination identifies all classes of supply, services, and DS maintenance available to the force. During disaster relief and humanitarian assistance operations, the G4 coordinates with the service component command on availability and

movement of Department of State or FEMA stockpiled relief supplies.

In austere areas, the division must plan with other USG agencies and, if applicable, the host nation and the Army service component command to establish an operational base prior to conducting peacetime activities. The operational base should be—

- Located far enough away from population centers to preclude civilian interference with operations.

- Located near roads and LZs.

Able to provide the task force with C³ facilities; CSS; personnel systems support; and staging

- Defendable in high-threat areas.

Command, Control, and Communications

Well-defined and effective C² structure is essential to successful peacetime actions. Peacetime activities are normally the result of a plan developed in conjunction with many USG agencies. These agencies include the Department of State, DEA, FEMA, US Forestry Service, and others. The division may be required to coordinate and plan with one or more of these agencies, as well as a host nation, if the operation is OCONUS.

Normally, the US ambassador assumes responsibility for US noncombat operations outside the United States. He heads a country team that interfaces with civilian and military agencies. The term "country team" describes in-country interdepartmental coordination among the members of the US diplomatic mission assigned to the embassy. They are charged with ensuring that US actions to accomplish regional and international objectives within a country are efficiently and economically administered. The regional command representative on the country team is the chief of the SAO. However, the defense attache officer (DAO) may also act as the SAO. The DAO works directly for the ambassador. The division staff initially establishes contact with the country team through the SAO or DAO. The SAO or DAO can provide information on the—

- US ambassador's goals for the host nation.
- Current threat.

- Involvement of other USG agencies, and points of contact (POCs).

- Current political situation.
- Usable supply routes.
- Airfields.
- Movement restrictions.
- Customs procedures.

Ž Host nation expectations.

Other ongoing peacetime activities (DOD and other USG agencies) within the host nation.

- Terrain management.
- Airspace restrictions.
- Weapons restrictions.
- Extent of HN role and support.

During brigade task force operations, the division provides a C² element to coordinate with the JTF, other USG agencies, and the host nation. The division C² element conducts as much of the coordination and interface as possible to ensure the brigade task force headquarters is free to focus on assigned and attached forces. If time permits, on-site surveys are conducted and an advance party precedes deployment of the main body. At a minimum, the division headquarters' advance party should consist of G3, G4, G5, ADSO representatives, and an Army lawyer. Initial coordination is made with the Army service component command and the SAO.

In some cases, the division may be relieving another force conducting peacetime activities. The advance party of the relieving unit then coordinates the following areas with the relieved unit:

- Lodgment.
- Transfer of property and supplies.
- Force protection plans.
- Contracting procedures.
- Completion status of projects.
- Engineering data.
- Environmental factors.

Use of air and sealift for backhaul of relieved unit.

- Host nation support.

Reserve and National Guard forces participate in many peacetime operations. Command and control arrangements need to be made early with the JTF through the Army service component command.

For large-scale, short-notice peacetime activities, an assistant division commander (ADC) and a tailored division assault CP may be deployed. The assault CP, configured for the particular mission, may have G1 to G5, ADSO, ADE, SJA, CA, provost marshal office (PMO), PAO, and PSYOP representatives, as well as LOs from USG agencies and the host nation.

The division's communications equipment should be sufficient for communicating with subordinate units. However, there are special communications requirements unique to peacetime activities. The ADSO plans for communication with the JTF, combatant command, host nation, and other USG agencies who may not have compatible equipment. Officers with communications equipment and SOIs may be required as LOs. This may require obtaining additional TACSAT communication equipment or commercial hand-held radios. The division may be required to provide communications support to the host nation and USG agencies. NOTE: Nearly all staff functions will require liaison. (See LO discussion in Chapter 2.)

As in combat operations, peacetime activities can benefit from the use of a synchronization matrix (Figure 6-3) to help coordinate actions. It allows the staff to record the results of war gaming and synchronize the COA across time, space, and purpose in relation to the most likely situational events that will occur. Regardless of the matrix format, each staff can adapt it to meet its needs. The staff should incorporate into the matrix other operations, functions, and units to be integrated or whose use the staff wants to integrate.

Force Protection

During peacetime activities, security is just as important as any other operation. The primary threat will be terrorism. Although the PM normally establishes the security plan for the division operating base, detailed coordination is made with HN forces about their roles and capabilities. The task force commander may

determine that infantry forces are needed to provide sufficient force protection. He takes appropriate steps to ensure security of his units.

Force protection is a critical consideration for the division staff. The goal of force protection is to conserve the fighting potential of the force so that the force can be applied at the decisive place and time. Force protection focuses on two areas: conserving our ability to generate combat power and denying the enemy the ability to generate combat power against us. The commander implements protection of the division through his force protection plan. This plan addresses all components of protection including survivability, deception, and countermobility operations. This plan includes both active and passive measures. FMs such as FM 5-114 focus on force protection planning and operations.

In some situations, the political environment may cause a rapid transition from a relatively peaceful environment to conflict. Detailed ROE contain graduated responses to a changing environment. Some considerations include use of riot-control agents, availability and use of snipers, stockpiling of basic loads, and augmentation by combat forces.

Rules of engagement during peacetime activities are restrictive, detailed, and subject to political scrutiny. Restrictions on the use of force are approved by the combatant command, clearly articulated, reviewed by the SJA, and disseminated to all echelons by the G3. Additionally, ROE for each weapon system will differ.

Legal Considerations

Generally, legal considerations for commanders conducting peacetime activities concern the use of proper funding authorizations for the type of mission being conducted. The SJA is responsible for monitoring expenditures of Foreign Assistance Act (FAA) funds, and operations and maintenance funds. Care must be taken to avoid using operations and maintenance funds for security assistance and development assistance activities. Additionally, commanders must be aware of *posse comitatus* and Title X restrictions on use of Army forces. The division's advance party for operations other than war should include legal counsel.

TIME	D-11	D-10	D-9	D-8	D-7	D-6	D-5	D-4	D-3	D-2	D-1
HIGHER HQs ACTION	WARNING ORDER CONDUCT PEACE ENFORCEMENT OPERATIONS	- RECEIVE CORPS OPLAN									H-HOUR IDENTIFIED
G1	BEGIN CMD ESTIMATE	- IDENTIFY LIQUIDS - MANAGE POM	- REQUEST LIQUIDS	- INCREASE MEDICAL STOCKPILES	- HES ESTIMATE ON HH HS CAPABILITY			PERSONNEL STRENGTH OPERATIONS COMPLETE FOR DEPLOYMENT		POSTAL OPERATIONS PLAN COMPLETE	
G2		- OBTAIN MAPS AND SATELLITE IMAGERY CONDICTION OF AIRFIELD AND ROAD NET	- PR AND AUGMENTATION REQUESTS TO MOHER							MI ROE AUGMENTATION COMPLETE	
G3	CONDUCT MISSION ANALYSIS OF THEATER CAMPLANS/OPANS	- REQUEST SATCOM ASSETS FOR JTF COMMO - REQUEST SOC C2 ELEMENT	- ABCC AUGMENTS W/OPS AND LOG PLANNERS	- REQUEST DTY DEPLOY ADVON AT D-1.5	- SOC C2 REPORTS - TYPDO AND POINTS OF DEBARICARION IDENTIFIED BY ABCC	REQUEST SOF CURRENT SITUATION	- ADVANCE PARTY DEPLOYS - ESTABLISH COMMO WITH SOF IN AO	LOG EXCHANGE W/ COMBATANT COMMAND JTF AND JTFOR COMPLETE	COORDINATE TYPDO WITH ABCC	RECOMPRM/TRACKS REQUIRED/AVAILABLE AIRFRAMES	
G4	AVAILABLE PUBLIC SERVICES		DEVELOP TOI FOR THEATER SUPPORT REQUIREMENTS	IDENTIFY POC FOR THEATER HUMANITARIAN ASSISTANCE STOCKPILES	RECEIVE ABCC AUGMENTATION		- LOG ESTIMATE COMPLETED - IDENTIFY ALL SUPPLY REQUIREMENTS		CONUS CONTRACTING REQUIREMENTS COMPLETED		
G5		ISSUE COUNTRY PROFILE TO SUBORDINATE UNITS	REQUEST CAPTOP AUGMENTATION		ASSESS HH SUPPORT CAPABILITY			PROVIDE COR WITH HH PUBLIC UTILITIES STATUS			
SJA		RECEIVE JTF ROE	PREPARE ROE FOR SUBUNIT DISTRIBUTION		BRSE COR ON USE OF FUNDS			ROE UPDATED AND DISSEMINATED			
PM			IDENTIFY LNO REQUIREMENTS TO HH LAW ENFORCEMENT AGENCIES		DETERMINE REQUIREMENTS FOR HH FORCE AUGMENTATION		BATTLEFIELD CIRCULATION CONTROL PLAN APPROVED	AREA SECURITY PLAN APPROVED	LAW AND ORDER POLICY APPROVED BY COMMANDER		
NON MILITARY AGENCIES		CRITICAL LOs		C2 OF NON DOD AGENCIES DECISION PROCESS		MEDIA/STRAP MANAGER MANAGEMENT					
CCIR	END STATE DESIRED/CONNECTED IMPLIED TASKS		SUPPORT REQUIREMENTS AND KEY ASSETS	COMMO REQUIREMENTS		TYPOL	MOE		LAW AND ORDER POLICY	ADVANCE PARTY ASSESSMENT	

Figure 6-3. Example of predeployment sync matrix

Special Operations Force Integration

During operations other than war, special operations command and control elements (SOCCE) are often provided down to divisions. These elements provide liaison between special operations forces and division forces operating in the division's AO. This liaison is accomplished by collocating a SOCCE at division's main CP. (See FM 100-25.)

The SOCCE provides C³ and intelligence to special operations forces within the division's AO. The SOCCE focuses on synchronizing and integrating the SOF with the supported division. It performs the following functions:

- Establishes and operates a cell at the main CP on a 24-hour basis.

- Advises the division commander on the employment, mission, current situation, capabilities, and limitations of supporting SOF units within the division's AO.

- Participates in the division's COA development.

Advises the supporting SOF commander of the division's current intent, situation, and requirements.

Provides required SOF communications links.

Synchronizes SOF with division operational and intelligence requirements.

- Coordinates division support of SOF.

- Receives SOF operational, intelligence, and target acquisition reports from deployed teams and provides them to the division commander and staff.

- Deconflicts special operations and other division operations.

- Assists the division staff planning for linkup with SOF.

The theater CINC normally dictates the command relationship a JTF has with SOF. OPCON or tactical control (TACON) are the two common command relationships that are designated.

CONUS Peacetime Activities Scenario

A major earthquake has occurred in a large metropolitan area, disrupting public services and causing hundreds of casualties. The governor of the state determines it is beyond the capabilities

of local authorities and the National Guard to provide services and relief, and requests federal assistance.

US Army Forces Command (FORSCOM) alerts corps headquarters for deployment in support of earthquake disaster relief operations. Based on initial assessments, FORSCOM directs the deployment of a logistics task force (formed around a corps support group) to establish feeding sites and a staging area for health care personnel and to provide vehicles. Later, the corps headquarters is ordered to deploy and assume the mission of the JTF. Corps issues a warning order to one of its light divisions to deploy and assume the ARFOR mission under the command of the corps JTF. The division implements its disaster relief OPLAN and deploys the advance party under the direction of the ADC-M. The division prepares to deploy appropriate C² and supporting units to accomplish the mission of disaster relief in AO Rolinda. The division invokes N-hour sequences and the first units begin arriving into AO Rolinda at N +20 hours,

The division commander's intent is to quickly deploy, establish liaison with local agencies, and provide life support and assistance to earthquake victims in the community. After coordinating with FEMA and local officials, the commander prioritizes resources, linking them to the specific needs of the community. The division-essential tasks are to—

- Conduct air-land operations.

- Conduct damage assessment of AO.

- Establish liaison with FEMA and local government agencies.

- Assist in establishing communications.

- Provide HSS.

- Establish feeding sites.

- Provide potable water.

- Assist in debris removal.

- Establish shelters.

- Support reconstruction activities.

- Assist in distributing donated items.

Maneuver

Early assessment of the extent of damage caused by a natural disaster is critical to tailoring the appropriate response package deployed to the AO. On notification, the division deploys an advance party to conduct a reconnaissance of the earthquake disaster site to—

- Assess total damage and recovery times.
- Determine requirements (including power generation).
- Select assembly areas.
- Establish liaison with local, state, and federal authorities and sister services.
- Ensure priority of work for the division is approved by local and federal authorities.

The advance party consists of the ADC-M, ADE, ADSO, PAO, provost marshal, liaison officers, contracting officer, and G3, G4, G5, DISCOM, and division surgeon representatives. The division plans to conduct this operation in four phases:

- Phase I: Conduct air-land operations.
- Phase II: Occupy assembly areas.
- Phase III: Conduct relief operations.
- Phase IV: Redeploy.

The ARFOR (division +) task organizes to ensure that subordinate units are robust and self-sustaining (Figure 6-4). To facilitate direct contact with disaster victims, forces are task-organized to operate in a very decentralized manner in neighborhoods that they support. Initial sorties in the airflow include the division assault CP; DFCP; signal, medical, and engineer battalions; and other units based on need.

The advance party at the disaster site provides continuous updates to the home station via commercial phone and TACSAT radio (to include verification of assembly areas). Reports are rendered according to the division TSOP. Forces arrive at the disaster site and move to and establish assembly areas. Liaison officers brief commanders on—

- Current missions, tasks, and roles down to squad level.
- Chain of command (for example, JTF, disaster control officer, federal control officer (FCO)) and location of headquarters.

- Current missions, tasks, and roles of all federal, state, and local agencies; National Guard; sister services; and private organizations.

- New liaison requirements.

- Public services status (for example, power, water, and commercial communications).

Command and Control

The division takes the initiative to establish command channels with the JTF, local agencies, USG agencies, and private organizations. Boundaries for subordinate units are drawn to encompass political subdivisions to facilitate coordination and cooperation with the local leadership (Figure 6-5, Page 6-12). Task force headquarters are located in municipal buildings and near other agencies' headquarters. Representatives from all local agencies are asked to send liaison personnel to the division and subordinate units CPs. Commanders at all levels meet daily with local leaders to ensure that the division's efforts focus on the needs of the disaster victims and the expectation of the local leadership.

Communications

The advance party is equipped with hand-held commercial radios, cellular phones, and TACSAT radio. The division contracts for commercial satellite communications channels and equipment and implements the signal support plan that supports the disaster relief contingency plan, Communications systems (MSE, RATT, and FM) arrive on the initial sorties and are quickly employed as primary sources for area communications until commercial systems are restored. A robust MSE network is established at the disaster site. Municipal buildings, hospitals, firehouses, and police stations are provided a MSE phone and assemblage. The signal battalion dispatches a liaison to FEMA's emergency support function (ESF) communications cell to ensure the ARFOR's and FEMA's communications objectives are compatible.

Intelligence

Prior to deploying, the G2 conducts intelligence preparation of the area of operations (IPAO). Products of IPAO include detailed satellite imagery of the AO (both before and after the earthquake), MSRs and airfield conditions, and

<i>1st Bde</i>	Corps Engr Group (DS)
HHC Bde	
Inf Bn	<i>DISCOM</i>
Inf Bn	HHC.DISCOM
Co Engr Bn (-) (Lt)	FSB
2/2 MP Co (DS)	FSB
Det 2 CA Bn (DS)	FSB
	MSB
	MCT
	MCT
<i>2d Bde</i>	HQ, ASMB (-)
HHC Bde	ASMC
Inf Bn	Med Det (VS)
Inf Bn	Med Det (SAI)
Co Engr Bn (-) (Lt)	Med Det (ENTO)
MI Bn (-)	Med Det (AA) (-)
2/3 MP Co (DS)	MED.DET (Log Spt)
Det CA Bn (DS)	
<i>DIVARTY</i>	
HHB.DIVARTY	COSCOM Forward (FWD)
FA Bn	
FA Bn	<i>Division Troops</i>
E Btry FA Bn	HHC/ Div
Co Engr (Lt)	PSC (-)
TAD	FSU (-)
1/3 MP Co (DS)	Postal Co (-)
Det CA Bn (DS)	Engr Bn (-)
	Engr Co (CSE) (-)
<i>Avn Bde</i>	PSYOPS Det
HHC Bde	CA Bde (-)
Recon Sqdn (-)	CA Bn (-)
Atk Bn (-)	CA Bn (-)
AHB (-)	Division Band
TF Corps Avn Group (-) (OPCON)	PAT. MPAD
1/2 MP Co (DS)	Provost Marshal
Det 3 CA Bn (DS)	MP Co
	Corps MP Bn
	MP Co
	MP Co
	MP Co
	MP Co
	Sig Bn
	Corps Sig Co/Corps
	Det (USAF) (-)
	Det (-) (WX)

Figure 6-4. Division task organization

weather forecast. Additionally, the G2 provides maps of the AO

Engineer Support

The ADE closely coordinates and works with the U.S. Army Corps of Engineers (USACE), FEMA, and National Guard senior engineers. The ADE works closely with the contracting

officer to ensure needed contracted equipment and drivers are quickly integrated into the relief effort. The engineer battalion initially focuses on emergency debris removal that affects public sanitation and safety. During relief operations, the engineer assets also assist in constructing life support centers, disaster assistance centers, and troop base camps. Engineer units design, install,

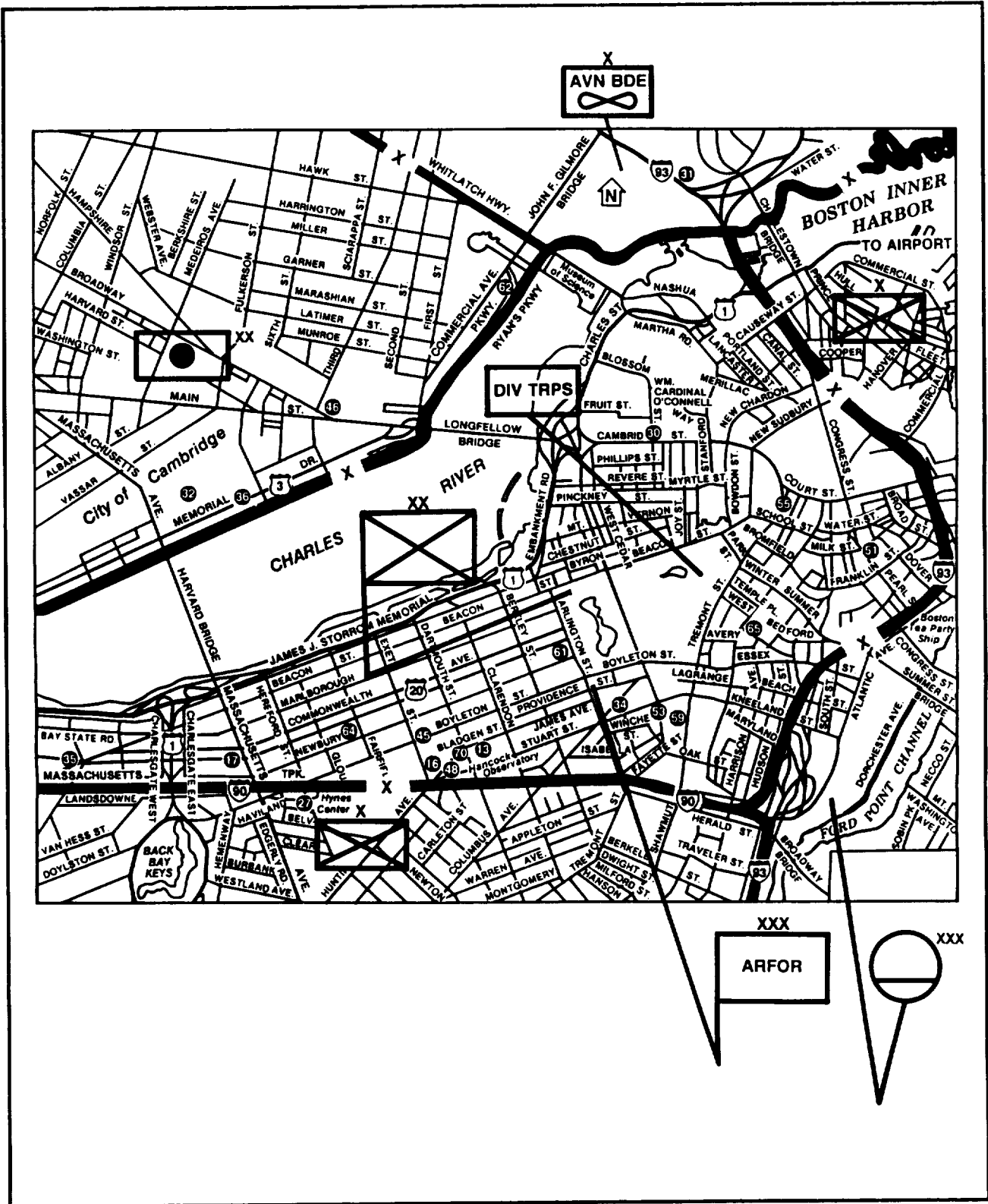

Figure 6-5. Area of operations

and wire tent cities in accordance with their contingency plans.

Additional military engineers (beyond the divisional organic light engineers) become involved with the division's disaster-relief operations as individuals, teams, or complete units. Individuals provide technical assistance to civil authorities in the areas of damage assessment and engineer work estimation. Teams provide specialized support such as well drilling, power supply and distribution, or utilities repair or reconstruction. Units with personnel and vehicles that perform general tasks are directed or task-organized to the division to support it in the earthquake-relief mission. Specific disaster-relief missions that engineers (division and EAD) accomplish are:

- Support for search and rescue operations.
- Clearance of rubble areas.
- Demolishing of unsafe structures.

•Opening of roadways for emergency and medical traffic.

•Restoration of critical facilities, services, and utilities.

- Construction of roads.
- Provision and distribution of water facilities.
- Provision of sanitation facilities.

•Construction of camps for displaced persons.

•Provision of emergency topographic engineering support.

- Engineer environmental studies.

Logistics

The DFCP deploys early and coordinates all initial aspects of logistics, to include contracting. The DFCP also ensures that sufficient fixed facilities and hard-stand storage areas and reefer vans are available to store and stage relief supplies. Logistics support of this operation is divided into two parts—support of the disaster relief effort and internal support of the ARFOR.

DISCOM establishes a logistics support base (wholesale distribution) into which all supplies initially flow. Supplies are then pushed to life

support centers (LSCs) according to priorities of resupply established according to population by FE MA. Priority or resupply is class I (MREs, T-rations), class IV, ice, and portable toilets. Strict accountability is maintained on all donated relief items.

Health Service Support

Prior to deployment, medical units develop contingency plans based on the initial HSS estimate. The division surgeon sends a liaison to the JTF surgeon to coordinate FEMA-directed requirements. HSS units establish aid stations to—

- Provide care for soldiers.
- Provide direct support to earthquake victims.
- Provide expertise and organizational support to FEMA's ESF 8 (coordinated federal response to support the civilian health care infrastructure). Such services include preventive medicine, public health, veterinary, dental, pharmacy (medical supply), evacuation, and treatment.

Preventive medicine personnel focus on educating victims on proper field sanitation procedures and insect, rodent, and animal control. Division medics provide Echelon I and II care to earthquake victims.

MP Operations

Military police efforts focus on traffic control, protection of ARFOR soldiers, physical security, and liaison with law enforcement agencies (LEAs) in the AO. Prior to deploying, the provost marshal plans for MP liaisons with all LEAs in the AO. The PM, through the contracting office, attempts to obtain commercial radios compatible with the LEA equipment.

MP liaisons ensure LEA officials are aware of *posse comitatus* limitations on the use of MPs. An SJA officer is attached to the MPs to screen LEA requests for MP support.

Public Affairs Officer

The PAO works closely with the JTF PAO who assists in coordinating interagency information, usually through a joint information committee (JIC). This committee provides a centralized clearing house for public information and synchronizes the flow of vital information

down to the division PAO. The PAO collocates with city officials to ensure the military story is disseminated.

POSTCONFLICT OPERATIONS

Infantry divisions may be required to transition from combat operations to postconflict operations. These operations focus on restoring order and minimizing confusion following the operation, reestablishing the HN infrastructure, and preparing forces for redeployment. Under the guidance of the Department of State and the JTF. Army forces may be directed to help reinforce or reestablish formal institutions eliminated during combat operations and ameliorate negative postcombat population attitudes toward the United States.

Many tasks that are not usually done by Army forces may become their responsibility until HN or USG agencies reestablish presence. These operations increasingly become inter-agency in nature as the ambassador and country team resume a larger role. The objective of these activities is not only to return to an environment of peace as expeditiously as possible, but also to increase the probability of sustained peace.

The division focuses on consolidation, reorganization, and similar operations during the initial stages of postconflict operations. During this time, units provide care to the wounded, consolidate and repair equipment and facilities, process prisoners of war, and reposition and prepare units for future operations. Normally, the theater commander will implement specific CONPLANS and OPLANS that address postconflict operations.

The division may simultaneously conduct peacetime activities and search and attack missions (that is, mop-up of enemy resistance and search for caches). The priority of effort is always to bring combat operations to a satisfactory conclusion. As hostilities terminate, the division prepares to task organize and direct its efforts toward peacetime activities. When the light division is involved in these peacetime activities, significant M/S requirements are common. Based on the division's METT-T analysis, the light division will normally require EAD engineer augmentation to support its operations and augment the capabilities of its organic engineers.

The division headquarters may be designated as the ARFOR during postconflict activities. The division, through the combatant command, establishes liaison with the other services, the theater special operations command (SOC), the country team, and, in many cases, HN officials.

The G5 begins to coordinate CA operations within the division AO. The division tasks available CA units—

ŽTo identify available local resources, facilities, and support.

- To assist the commander in meeting legal and moral obligations to the local populace (by temporarily providing support of goods and services through the HN agencies to the local populace).

ŽTo serve as liaison with other USG agencies and the host nation.

- To assist the G2 in assessing the current threat.

ŽTo act as the staff focal point for cultural considerations.

ŽTo conduct a needs assessment of the local population.

ŽAt the request of the host nation, to establish a temporary civil administration to maintain law and order and to provide life-sustaining services until the host nation can resume normal operations.

The G5 coordinates PSYOP units OPCON or attached to the division. Generally, PSYOP missions aim to build favorable attitudes toward the United States among HN populace and acceptance of the HN government. PSYOP units conduct psychological assessments, counter-propaganda, printing, loudspeaker operations, audiovisual operations, and PSYOP planning and product development. The division PAO coordinates and approves release of all public information, including PSYOP products.

Infantry brigades not involved in combat operations may be tasked by the division—

ŽTo assist in the performance of law and order functions in urban areas.

- To provide force protection.

- To establish contact with rural, isolated populace.

- To assist SOF forces to stabilize rural areas of dissent.

ŽTo implement “money for arms” programs to disarm the population.

- To respond to threats to the host nation government at the request of the host nation and the country team.

- To train HN self-defense forces.

ŽTo assist in reconstruction of urban areas.

ŽTo provide humanitarian assistance.

The DISCOM and the divisional units play a vital role in postconflict operations. The engineer battalion may be tasked to provide limited vertical and horizontal engineering construction and maintenance support to the host nation and support mine clearing operations. Medical companies in the MSB and FSBs may be tasked to provide medical treatment to the local populace as well as limited preventive medicine educational programs. The MP company may provide support by conducting joint patrols, maintaining order, and evaluating host law enforcement operations. Detailed ROE for MP activities is essential. (Handling of detainees is a big issue.) The Foreign Assistance Act of 1961 forbids the military from training police. However, MPs are assigned as liaison with HN police and Department of Justice personnel to train police. The aviation brigade is tasked to provide aerial resupply, air movement of personnel and equipment, and C² aircraft.

During the period of postconflict operations, the division staff may be required to simultaneously plan and execute multiple operations. These include:

- Combat operations.
- Peacetime activities.
- ARFOR missions and tasks.
- Redeployment of the division.

The division may focus its C² assets to an operation. For example, the assault CP commands and controls combat operations; the main CP plans for redeployment and monitors the combat operation and ARFOR tasks; and the rear CP and DISCOM support combat operations and command and control peacetime activities.

CONFLICT

The Army’s role in conflict is to gain control of a crisis situation and restore peace. This type of action is difficult since it involves the measured application of sufficient force to re-establish an environment of peace. In most cases, the division is committed to short-duration combat operations with limited objectives. Although combat operations under these circumstances are normally short and limited, the division is likely to become involved in extensive postconflict operations. Because of its strategic mobility, the infantry division plays a major role as part of a JTF in conducting operations in this type of environment.

Operational Planning

Most of the considerations previously discussed in peacetime activities also apply in conflict. In the conflict environment, the division proceeds through the eight stages of force projection:

- Mobilization (as needed).
- ŽPredeployment activity.
- Deployment.
- ŽEntry operations.
- ŽOperations.
- Postconflict operations.
- ŽRedeployment and reconstitution.
- ŽDemobilization (as needed).

Predeployment and crisis action is a critical phase because success during other phases predicates on successful planning during predeployment. During this phase, the division tailors and task organizes forces and refines operational plans for subsequent phases of the operation.

Planning and preparing for strategic deployment in the compressed time frame of a crisis is demanding. The division provides to corps critical information on the size of the force deploying, and the lift required to deploy it.

While corps planners conduct X-Hour execution planning, the division’s state of readiness is increased. Division forces are alerted and begin preliminary measures to deploy. Corps announces

N-Hour (execution notification) and the division begins a sequence of events ending with the lead elements of the force deploying to the objective area. The following example briefly describes the division's major activities in an N-Hour sequence. (See Figure 6-6.)

<i>Time</i>	<i>Unit Activity</i>
N-hour	<ul style="list-style-type: none"> • Receive alert notification. • Activate division emergency operations center (EOC). • Alert division ready brigade (DRB) and outload units.
N + 2	<ul style="list-style-type: none"> • Division ready force (DRF#1) (first battalion alerted) 100% assembled. • N + 2 situation and mission brief at division. • DRB and DRF planning commences.
N + 3	<ul style="list-style-type: none"> • Assembly reports from units.
N + 3:30	<ul style="list-style-type: none"> • Division outload support meeting. • Minimum mission essential equipment redistributed.
N + 9	<ul style="list-style-type: none"> • Division EOC receives unit status reports.
N + 10	<ul style="list-style-type: none"> • DRF#1 moves to airfield.
N + 18	<ul style="list-style-type: none"> • DRF#1 wheels up.

Figure 6-6. Division activity in conflict

The division applies tactics and techniques described in this manual according to METT-T-P. The division may provide forces to conduct combat operations or to support or reinforce a SOF mission.

Once alerted for a possible mission, the division staff coordinates planning efforts with key participating commands. This includes the Army service component command, the combatant command or JTF, and the regional SOC.

Theater campaign and operation plans are the starting point in the division's tactical decision-making process and development of subsequent division OPLANs. Theater plans should provide—

- Intelligence estimate.

ŽCINC's intent.

ŽKey objectives.

- Rules of engagement.

ŽSustainment concept.

ŽDeception plan.

- PSYOP and CA employment.

- Joint fires.

- C³ structure.

ŽNEO requirements.

Division OPLANs are normally in five phases:

- Phase I. Insertion into the objective area and linkup with SOF.

- Phase II. Isolation of the objective area from enemy support or reinforcement.

- Phase III. A synchronized, violent, and surprise attack.

ŽPhase IV. Consolidation and stabilization (in some cases, relief in place).

- Phase V. Redeployment.

Detailed coordination is required between the division, corps or JTF, regional SOC, and SOF direct action force (such as ranger regiment) in operations requiring division forces to support or reinforce SOF. Because many missions in this environment are time-sensitive and require detailed planning and precise execution, the division includes subordinate headquarters directly involved with the SOF mission in the planning process. Specific division and SOF areas of planning include—

ŽIPB.

- SOF scheme of maneuver.

ŽLinkup.

ŽFire support.

- Command and control.

- Communications.

- Relief in place.

- A²C².

- Ground and air transportation.

ŽNEO.

- Health service support.
- EPW handling.
- PSYOP.
- Logistics.

The assault CP deploys early into the operation to synchronize division assets. The primary functions of the assault CP are to coordinate fires and phase in forces. The assault CP establishes communication and liaison with corps or JTF headquarters, SOF C² elements such as the JSOTF, regional SOC headquarters, and the SOF direct action force headquarters (ranger regiment and Special Forces (SF) group). Chapter 2 provides a detailed description of assault CP operations.

Once the SOF operation is completed, the assault CP then transitions from supporting the SOF mission to conventional command and control of the operation. The assault CP plans to assist the extraction of SOF forces by providing FS, security, and transportation of SOF. The division conducts a relief in place and assumes responsibility for SOF areas of operation. The division continues contingency planning to support future SOF operations.

The factors of METT-T-P drive tailoring of forces and task organization. The airborne and air assault divisions normally task organize the lead elements of the crisis response force for forcible entry. (See lodgment discussion, page 6-28.) A light division is normally the follow-on division. Divisions are organized into assault, follow-on, and rear echelons.

Assault Echelon

The assault echelon of the airborne and air assault divisions comprises those forces required to seize assault objectives and the initial airhead. While the primary mission of an assault force is to seize assault objectives, it must also be task-organized to assist the follow-on force and its transition to combat operations. As the follow-on division, the ID(L) may task organize its initial air-land sorties as an assault echelon to reinforce and expand the airhead or as the first forces to conduct subsequent combat operations.

Follow-on Echelon

The follow-on echelon enters the objective area as soon as practical by air, by surface

movement, or by a combination of the two. Its mission is to conduct subsequent combat operations. The following conditions require an infantry division to have a follow-on echelon:

- Shortage of aircraft.
- Equipment which must be air-landed.
- The factors of METT-T-P.

Rear Echelon

The rear echelon includes support and administrative units not essential for initial combat operations. Rear echelon units are brought in when the division remains committed for a prolonged period.

Types of Operations

This section discusses five operations conducted during conflict. They include:

- ŽShows of force.
- ŽAttacks and raids.
- Counter guerrilla operations.
- ŽBase defenses.
- ŽLodgement.

Shows of Force

Shows of force are missions carried out to demonstrate US resolve in which US forces deploy to defuse situations detrimental to US interests or national objectives. Shows of force may be used to lend credibility to national commitments, increase regional influence, and demonstrate resolve. Operation GOLDEN PHEASANT in 1988 is an example of a show of force. During this operation, a force consisting of elements of the 7th Infantry Division (Light) and the 82d Airborne Division deployed into Honduras to demonstrate US resolve against Nicaraguan border incursions. Infantry divisions can be used as a show of force either in response to certain threats or as a routine exercise.

As with other contingency operations discussed in this chapter, the political nature of the operation prevails. Since the object is not the use of force, legal and political constraints apply. As with peacetime operations, detailed planning with the regional Army service component command, the combatant command and SOC, and the country team is essential.

Forward deployment and basing of division forces is vital to a show of force. The division deploys its forces using the crisis response process and plans to establish required intermediate and forward operating bases to introduce and sustain forces.

In the show of force, the division plans for combined and joint training exercises and the transition to combat operations. As with other contingency operations, the division plan must support regional campaign and operation plans. The division plans training that supports its METL and facilitates its transition to combat operations. This requires—

- Coordinating in detail with other services and the host nation. (See Peacetime Activities, page 6-2.)

ŽDeveloping a training plan.

- Selecting ranges and training areas located in or near the terrain where combat operations may occur.

- Maintaining and positioning the basic load of ammunition.

ŽPlanning a deception.

- Conducting masked rehearsals.

- Positioning division CPs.

- Planning fire support.

ŽPositioning aircraft.

- Establishing reconnaissance and surveillance sites.

ŽEnsuring force protection.

Show of force provides an excellent opportunity to rehearse operations. However, highly classified OPLANs may prevent standard troop leading procedures (such as, company, platoon, and squad orders) to take place. The use of live-fire range scenarios similar to the scheme of maneuver of a specific OPLAN ensures OPSEC and prepares units. Units rehearse maneuver and actions at the objective as they would be executing the OPLAN. Another technique is the use of battle books. Battle books are basically OPORDs developed by higher headquarters (which have sufficient staff officers with security clearances). For example, brigades develop and store battalion

OPORDs (battle books) and then release them at the appropriate time.

Both techniques were used to prepare soldiers of the 193d Infantry Brigade (Light) weeks prior to Operation JUST CAUSE in 1989. Since the OPLANs to attack specific Panamanian Defense Forces (PDF) objectives were classified top secret, the majority of the leadership below battalion level could not access the OPLANs and conduct appropriate troop leading procedures. The brigade then developed battle books for each echelon down to squad level. The brigade focused its training toward live-fire exercises designed to simulate conditions that the force would face executing the OPLAN.

Attacks and Raids

The division may conduct limited attacks to create situations that facilitate seizing and maintaining political and military initiative. Usually, the division conducts attacks to achieve specific objectives other than gaining or holding terrain. The fundamentals of attacks are discussed in Chapter 3.

Attacks in this environment are characterized by a measured use of combat power and strict ROE. Attacks are normally used to damage or destroy HVTs. Successful attacks are characterized by—

- A start time and location not known by the enemy.

- Covert planning, rehearsal, and deployment.

ŽSwift, violent, and precise actions that focus full combat power at the decisive time and place.

- Use of all available combat power assets.

- Detailed coordination with friendly in-country forces and SOF.

Counter guerrilla Operations

Special operations forces are well suited to conduct counter guerrilla operations. Infantry divisions may be required to conduct counter guerrilla operations as part of the internal defense and development (IDAD) program geared to counter insurgencies.

Normally, division forces will not be committed until guerrillas begin to mass forces and

challenge government forces openly. The division defeats guerrilla forces by such tactics as—

- Search and attack.
 - Reconnaissance in force.
- Ž Deliberate attack.

Ž Military operations on urbanized terrain (MOUT).

Base Defenses

The division defends support bases, airfields, DSAs, FS resources, and other temporary or semi-permanent bases. Base defense is established to provide all-around security for the base with available forces. It is characterized by detailed planning and centralized control. Normally, base defense operations are executed under the command and control of the rear CP. The rear CP has OPCON of all forces assigned for base defense. Each base commander is responsible for its local defense.

Lodgment

The division may be directed to establish a lodgment in the JTF AOR. A lodgment is an airhead or a beachhead in a hostile or threatened area which, when secured, permits the delivery of forces and supplies and provides maneuver space for operations.

There are basically two types of lodgment operations, forcible and unopposed entry. Normally, airborne, air assault, and SOF forces are used to conduct forcible entry operations. Light infantry divisions normally conduct unopposed lodgment operations.

In both cases, Army forces are normally directed to secure areas which may include an airfield to facilitate the buildup of forces within the lodgment. Marine forces are normally charged with establishing beachhead lodgments during contingency operations.

It is essential for forces involved in forcible entry operations to strike hard and finish rapidly. Operational security prior to deployment is critical. The ground tactical plan for any assault operation has seven essential elements developed in the following sequence:

- Ž Determine airhead line.

Ž Select assault objectives.

Ž Determine placement of reconnaissance and surveillance forces.

- Establish boundaries.

Ž Task organize for the assault and facilitate introduction of follow-on forces.

- Maintain a reserve.

Fire support assets (specifically, air and attack helicopters) are used to prevent the enemy from massing and reacting to the assault. Surprise is critical to ensure rapid seizure of the airfield and establishment of a secure lodgment.

The scenario that follows discusses phases of deployment and initial combat, force buildup, and combat operations of contingency operations for the establishment of a lodgment.

Conflict Scenario

Vital US interests and US citizens have been threatened by a coup in a country with which the United States has diplomatic relations. The NCA has been unable to establish an agreeable solution to the problem through diplomatic means and deems the use of military forces necessary to protect US vital interests and citizens. The NCA has directed the JCS to issue an executive order to the responsible regional CINC to execute the appropriate contingency OPLAN. The CINC, in turn, notifies forces allocated under the OPLAN for contingency operations in theater. Under the OPLAN, one corps with two divisions has been allocated. The corps is to function as both JTF headquarters and ARFOR for the operation. The corps has alerted its respective divisions. Divisions have invoked N-Hour sequences.

Conceptually, the corps' airborne division has been directed to conduct operations to seize an airfield and establish a lodgment. The corps' light infantry division is designated as the follow-on division with the mission to conduct subsequent operations, as required.

During the crisis action and predeployment phase, corps and division air assets are airlifted to an intermediate staging base (ISB) in a friendly neighboring nation and are prepared for combat. Aviation assets are prepared to insert into the objective area at H-Hour, D-Day.

The principal focus of this operation is to secure a lodgment and build up combat power as quickly as possible, rapidly expand the lodgment, conduct operations to protect vital US interests, and, if necessary, conduct NEO of US citizens and other designated friendly personnel.

Threat forces are infantry battalions equipped with some light armored vehicles. These forces are expected to defend the international airport, port facilities, other smaller airfields, command and control sites, and unit garrison areas.

The corps commander's intent calls for simultaneous attack on all objectives, night operations, and swift entry. Additionally, collateral damage will be kept at a minimum. The corps essential tasks include—

• Seizure of the international airfield and establishment of a lodgment.

• Closure of the remainder of the airborne division and the ID(L).

• Expansion of the lodgment.

• Conduct of link-up operations between airborne forces and SOF and the ID(L).

• Expansion of the security area out to the range of threat organic indirect fire weapons to protect airfield operations.

• Conduct of offensive operations to destroy, delay, or disrupt enemy forces threatening the lodgment.

• Conduct of NEO, as required.

In this example, the division plans to conduct airborne operations initially with a one-brigade task force designated as the main effort. Following seizure of the airfield, a second brigade air-drops into quickly build up forces in the lodgment area. The plan assumes sufficient airframes are available. Figure 6-7 shows the division plan.

The 1st and 2d brigades conduct a night parachute assault into two DZs in the objective area. The 1st brigade assigns assault objectives (including the airfield facilities) to each of its battalions. As the 2d brigade arrives in the airhead, the airhead line is expanded and adjusted to accommodate the supporting brigade

effort. Attack helicopters from the aviation brigades and cavalry squadron self-deploy from the ISB to support airhead operations. The FARPs are initially established using corps aviation assets until air-land operations commence.

Tactical surprise and detailed planning enable units to seize assault objectives and establish the airhead before the enemy reacts in force. Subordinate unit missions are changed as required by the enemy defense. When initial assault objectives are secured, units expand the airhead.

On assembly, assault forces seize their objectives and clear assigned sectors. As assault objectives are seized, efforts of the assault force are directed toward consolidating the airhead along the airhead line. Defensive positions are organized, communications established, reserves reconstituted, and other measures taken to prepare the force to repel enemy counterattacks. Blocking positions are established to deny access to and from the airfield. The cavalry squadron and aviation brigade screen the airhead line against enemy movements.

The division establishes a perimeter defense along the airhead line. The airhead line anchors on obstacles and on the airhead itself and takes advantage of existing man-made and natural obstacles. The perimeter defense is large enough to provide airfield protection from direct fire weapons and threat anti-aircraft systems.

Once assault objectives are seized and the airhead line defended, follow-on airborne and air-land operations commence to close in the remainder of the division. The ID(L) follows the airborne division into the lodgment area and occupies assembly areas and prepares for future operations as required by the OPLAN. These may include air assault operations to expand the airhead line or to seize other critical objectives.

During the planning phase of the contingency operation, the division conducts extensive coordination and exchanges liaison officers. Shared information includes—

• Intelligence updates.

• Staging and air movement plans for the airborne and air assault operations.

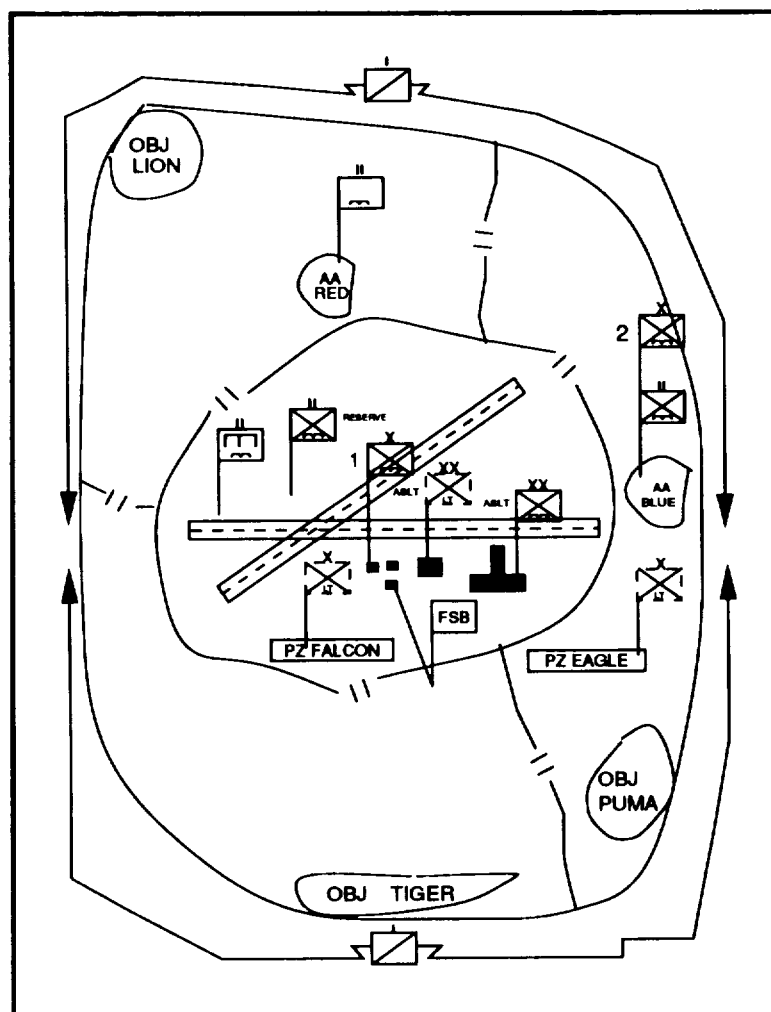

Figure 6-7. Division plan: establishment of a lodgment

- Communications.
- Fire support plans.
- Location of assembly areas.
- Location of contact points.
- Host nation support.
- Availability of water, rations, and health service support.

As assault objectives are secured, brigades begin to establish the airhead line. Patrolling is started early between adjacent defensive positions within the airhead line and between the airhead line and the forward screen line. Battle positions are oriented toward enemy avenues of approach. As the air attack battalion arrives, it

orients on the main avenues of approach and serves as a counterattack force.

Conduct of Operations

Maneuver

The airborne division assigns assault objectives, conducts a night parachute assault, and establishes the airhead line. The corps assault CP is inserted immediately following the airborne assault. The division plans a four-phase operation. The phases are—

- Phase I: Conduct parachute assault and secure assault objectives.
- Phase II: Link up with SOF forces.

ŽPhase III: Establish a perimeter defense of the airfield.

•Phase IV: Conduct NEO and facilitate introduction of follow-on forces.

Figure 6-8 shows the current airborne division task organization. Figure 6-9 shows the current follow-on division task organization.

1st Bde	2d Bde	Division Troops
Abn Inf Bn	Abn Inf Bn	Armd Bn (-)
Abn Inf Bn	Abn Inf Bn	Cav Sqdn
Abn Inf Bn	Abn Inf Bn	Engr Bn (-)
FA Bn (105T)	FA Bn (105T)	MP Co (-)
Stinger Tm	Stinger Tm	MI Bn (-)
Engr Co	Engr Co	FSB (-)
PSYOP Det	PSYOP Det	
MP Plt	MP Plt	
<i>Cbt Avn Bde (ISB)</i>	<i>DISCOM</i>	
Atk Bn	MSB (-)	
Aslt Bn		
AVIM Co (-)		

Figure 6-8. Airborne division task organization

1st Bde	2d Bde	Division Troops
Lt Inf Bn	Lt Inf Bn	Recon Sqdn
Lt Inf Bn	Lt Inf Bn	Engr Bn (-)
Lt Inf Bn	Lt Inf Bn	MP Co
FA Bn (105T)	FA Bn (105T)	MI Bn (-)
Engr Co	Engr Co	Stinger Tm
PSYOP Det	PSYOP Det	
FSB (-)	FSB (-)	
Stinger Tm	Stinger Tm	
<i>Cbt Avn Bde (-)</i>	<i>DISCOM</i>	
Atk Avn Bn (-)	MSB (-)	
Aslt Hel Co		
Aslt Hel Co		

Figure 6-9. Follow-on infantry division (light) task organization

The ID(L) conducts air-land operations into the airhead once it is secured. This is a three-phase division operation.

- Phase I: Conduct air-land operations.
- Phase II: Link up with assault forces.
- Phase III: Conduct air assault operations to secure key objectives.

During each phase of the operation, the division maintains focus on close and rear operations of the battlefield framework.

Deep Operations. The corps monitors enemy forces that could disrupt the force buildup at the airhead. These forces are targeted and engaged if they attempt to move toward the airhead. Attack is normally by USAF assets, artillery, or attack helicopters.

Close Operations. Special operations forces are inserted into the .40 prior to the airborne assault to determine enemy dispositions, ADA sites, and airfield status. These teams maintain radio contact with the airborne commander *en route* to the objective area.

Rear Operations. The division's CSS units are early in the airflow and begin air-land movement into the airhead once the perimeter defense is established. Service support is prioritized to sustain the lodgment site and support subsequent operations.

Security Operation. Security operations begin immediately after the parachute assault. The LRSUs and battalion scouts move to maintain surveillance on key avenues of approach into the airhead. As the cavalry squadron arrives, a 360-degree aerial and ground screen is normally established around the airhead. As combat power at the lodgment site increases, the division expands the security zone out past the range of enemy organic indirect fire weapons.

Reserve Operations. During the initial parachute assault, the least committed infantry battalion usually is designated as the reserve. Its primary tasks are to be prepared to assume the missions of misdelivered units and deal with unexpected opposition in seizing assault objectives.

On arrival, the armored platoon, inserted into the objective area by the low altitude parachute extraction system (LAPES), assumes the mission of the reserve. The reserve is not assigned assault objectives or a sector of the airhead to defend. The reserve may occupy blocking positions pending commitment. Primary tasks during the perimeter defense are to be prepared to block penetrations, reinforce committed units, and counterattack.

Intelligence

Prior to conducting the parachute assault, the division staff constructs a comprehensive IPB of the AOs and interest. As information becomes

available from corps, the staff updates the IPB. The division commander's PIR focus on the—

- Type, number, and location of enemy air defense, observation, and warning systems.
- Capabilities of enemy reaction forces near the objective.
- Long-range weather forecast at both staging and objective areas.

As the perimeter defense takes form, battalions develop R&S plans and submit them to their brigades. Brigades submit their plans to the division G2 to ensure the division sector is completely covered. Primary tasks for R&S actions are to detect enemy infiltration into the airhead and counterreconnaissance.

The MI battalion provides direct support to brigades with company teams. It also provides general support to the division. When available, Quickfix is used to detect enemy forces. REMBASS strings are placed along likely routes into the airhead and covered by active patrolling. Voice intercept assets are used to detect enemy units. GSR assets are positioned to detect infiltration of the airhead line.

In this type of operation, areas of operations and interest may be constrained. This may complicate LRSD operations. The division G2 plans and coordinates LRSD employment and the G3 executes the plan. Selection of NAIs and TAIs determines actual positioning. However, careful coordination must be made with corps and JSOTF to ensure no duplication of effort and to avoid fratricide. The G3 coordinates the RFAs over each LRSD location with the SOC cell.

Fire Support

Fire support in this example assumes a forcible entry operation in a nonpermissive environment. In a semipermissive environment, ROE for fire support may be restrictive and limited to a response in kind. Fire support for the airborne assault is provided by Air Force CAS and Army attack helicopters. Normally, very restrictive ROE will require precision fires to support contingency operations. In this example, fire support by USAF AC-130s and CAS using precision munitions and AH-64 attack helicopters concentrate on isolating objective areas and neutralizing enemy forces on assault objectives. Care is taken

not to damage the airfield or its facilities. Artillery and mortars provide fire support following the parachute assault.

In this example, the FS plan provides one DS artillery battalion to each maneuver brigade. Synchronization between maneuvering battalions and fires occurs as artillery moves with maneuver forces and quickly responds to eliminate pockets of resistance in sectors. AC-130s provide on-call precision fires on enemy locations. The AC-130s also provide a night reconnaissance capability, providing real-time information on enemy locations to assault forces. FSE personnel may be on board to facilitate synchronization of fires.

An AN/TPQ-36 mortar-locating radar is placed DS to each FA battalion and oriented toward templated suspected enemy mortar positions. Batteries are prepared to provide indirect fires on massed enemy targets detected by reconnaissance and radar. The AN/TPQ-36 cannot be air-dropped and must be air-landed during deployments.

Mobility and Survivability

Engineers and runway repair and maintenance packages are inserted early during the parachute assault. Following the airborne assault, engineers begin to clear runways, ramps, and airfield facilities. Light engineer teams begin to immediately breach and clear lanes of enemy obstacles. Once completed, these teams begin to emplace protective obstacles on highspeed avenues of approach into the airhead. Heavy equipment (bulldozers) are inserted by LAPES to clear obstacles off runways.

Once runways are cleared of obstacles and capable of receiving follow-in aircraft, priority of engineer effort shifts to countermobility and then survivability. The major threats to the airhead are surviving remnants of any enemy armor companies, indirect fires, and infiltrating enemy. Engineer units also assist in building fortifications for CPS and CSS assets. Class IV is delivered by CDS to fortify battle positions.

Air Defense Artillery

Under all but the most unusual circumstances, air superiority along the route to and at

the objective area will have been established. However, normal task organization to provide air defense to the airhead will be implemented. During the initial stages this will normally be only Stinger teams. Vulcans (being replaced by Avengers) may be either air-dropped or air-landed into the objective area.

Combat Service Support

The division plans for airdrop resupply by CDS. Priority of resupply is class V, class IV, class VIII, and class I. Materiel handling equipment is brought in early to facilitate rapid unloading and movement of cargo once air-land operations commence. Medical evacuation sites and forward stock sites are established on the airfield. Casualty evacuation from the airhead will be by C-130. Distribution to supported units is accomplished by a combination of supply point distribution and aerial resupply via CDS and or LAPES.

During the early stages of force buildup, maintenance support will rely primarily on component repair, battle damage repair, and cannibalization of combat damaged equipment. As the operation progresses, the level of support will increase with the complete deployment of the division and introduction of corps assets.

NBC Operations

The airborne division chemical company will not normally be involved in the parachute assault unless the IPB indicates the threat possesses a chemical capability.

Command and Control

The airborne division assault CP is in the initial parachute assault and locates generally in the center of the airhead to synchronize air and ground operations, as required, and to request and allocate corps assets. It fights the close fight, synchronizes the flow of follow-on units into the AO, phases them into the fight, and begins the initial planning for future operations. It is the C² link between division forces on the ground, in the air, and at home station, and the corps (JTF) headquarters. The assault CP controls the arrival of division units as they close in on the airhead. The assault CP hands off rear area responsibilities to the rear CP on their arrival.

The assault CP is responsible for determining when the airhead is secured and prepared for the arrival of the follow-on ID(L). Another assault CP task is airspace management in the objective area. Especially critical is controlling the arrival of helicopters from the ISB and their employment in and around the airhead. The airborne division assault CP may be required to plan and coordinate the staging plan for the ID(L) air assault operations.

The assault CP ensures brigades are not distracted from their primary tasks. Brigade assault CPs command and control attacks on assault objectives. The focus of brigade commanders is to secure assault objectives and establish the airhead line as quickly as possible.

The initial assault stresses the coordinated action of small units to seize initial objectives before the advantage of surprise is lost. As assault objectives are seized, efforts of the assault force are directed toward consolidating the airhead. The division commander influences the battle by shifting or allocating fire support, moving forces, modifying missions, changing objectives and boundaries, employing reserves, and moving to a place from which to exercise personal influence.

The follow-on ID(L) assault CP will normally arrive with the first sorties of the division. The assault CP is established near the airborne division assault CP. Because of the proximity of forces, detailed coordination between divisions is essential.

MP Operations

During the initial assault, MF units secure EPWs taken by assault forces. Following the airborne assault, the MP company (-) secures the logistics area and the division assault CP and is prepared to provide battlefield circulation control and area security missions in the brigade area.

NONCOMBATANT EVACUATION OPERATIONS

Noncombatant evacuation operations relocate noncombatants in a foreign nation who are threatened by hostile action or hazardous environment. Evacuees may include US citizens, and designated HN personnel or third country aliens friendly to the United States. NEO normally

involves swift insertion of SOF and conventional forces, temporary occupation of an objective to protect evacuees followed by a rapid evacuation, and planned withdrawal of forces.

The division conducts NEOs in three types of environments:

- **Permissive NEO.** In this situation, no hostility is expected. The evacuation force performs its evacuation mission using the minimum-essential force. Defensive perimeters are established, road convoys escorted, and screening procedures implemented at both the assembly area and the evacuation site.

- **Semipremissive NEO.** In this situation, disturbances, mob violence, and small pockets of armed dissidents are expected. The evacuation force commander must plan to deal with hostile crowds and should consider using riot control agents on authority from the regional combatant command.

- **Nonpermissive NEO.** In this situation, the military objective is to get Americans and others out of danger. The evacuation force employs all required measures to protect itself and to provide security for evacuees. If the use of violence is required, it will be the minimum necessary to ensure the safe evacuation of noncombatants.

Divisions provide forces to conduct NEO. Additionally, the division may be tasked to command and control all phases of NEO. As with other contingency operations, NEO requires close coordination with SOF and other US government agencies.

Operational Planning

The two most important documents in planning for NEO are the OPLAN from the regional combatant command or Army service component command and the embassy evacuation plan (EEP). Under most circumstances, a JTF commander has supervisory responsibility for the entire operation with the evacuation ground force commander working for him. The OPLAN specifies the command relationship between the evacuation ground force commander and the ambassadors of countries involved in the operation. The OPLAN includes—

- Designation of an ISB

- Evacuation sites.

- The safe haven location.

- The embassy evacuation plan.

An ISB may serve as a refueling point or staging area where a NEO force waits for approval to enter a host nation. Normally, the ISB is under the direction of the rear CP. The JTF headquarters decides whether or not an ISB is necessary. Considerations for selection of an ISB are—

- Flight time from home base and to the NEO site.

- Host nation accessibility.

- The ISB's isolation and defendability.

- The capacity and location of available airstrips, ports, and other transportation facilities.

- Communications.

- Its use as a safe haven.

Evacuation Ground Force

The division task organizes an evacuation ground force into a C² element, marshaling force, security force, administrative element, and logistics element. The factors of METT-T-P determine the size of this force. Normally, this force is a brigade task force under the direction of the assault CP.

Command and Control Element. The assault CP normally is deployed to direct the operation and conduct liaison with the embassy staff, JTF, SOF, and host nation. The task force commander normally commands and controls the marshaling and security forces.

Marshaling Force. The primary functions of the marshaling forces include the securing of designated assembly areas, initial screening and identification of evacuees, collection of evacuees and movement to assembly areas, and escort of evacuees to the evacuation site.

Security Force. The two primary missions of the security force are evacuation site security and reaction force response to emergency situations.

Administrative Element. The administrative element is responsible for the operation of the evacuation site processing center. The DISCOM headquarters directs this effort.

Logistics Element. Logistics support for the evacuation ground force is provided by the FSB which tailors LOGPACs according to METT-T. This is usually limited to minimum-essential support and consists of a service and transportation unit, a HSS unit, and a maintenance unit. In most cases, the FSB is established in the ISB. Whether supplies to support evacuees come from the division or the Department of State determines the size of the logistics support package.

Safe Haven Force

This force controls and operates the safe haven. The safe haven force goes directly to the safe haven. Elements of the rear CP direct this force which comprises primarily CSS operations. It consists of five elements: C², reception, processing, comfort, and departure.

Advance Party

The actions of the advance party are key to successful NEO. The situation may allow the evacuation ground force commander to send an advance party into the country prior to the arrival of the main body. If the situation prohibits an advance party, then one of the first elements in the main body to land must immediately assume the advance party mission. The responsibilities of the advance party personnel include:

- Confirming the US embassy evacuation plan.

• Determining actual numbers of personnel, equipment, and material to be evacuated.

• Verifying identification of evacuees, their location, emergency medical concerns, and any special US embassy requirements.

• Locating PZs, assembly areas, and evacuation site.

• Designating evacuation routes and alternate routes.

- Checking suitability of the evacuation site.

- Updating intelligence estimates.

Acquiring additional maps, photos, and city plans, as needed.

• Confirming transportation support to move evacuees.

- Conducting an area reconnaissance.

- Identifying special communications requirements.

- Determining HN support availability.

- Establishing funding authority and POCs for HN support.

- Establishing how the US embassy will handle the news media.

- Briefing the ambassador and selected US embassy staff on the concept of military operations.

The advance party coordinates with the US embassy on the location of the evacuation site and on its preparation for the arrival of the evacuation ground force. Some selection criteria for the evacuation site are its—

- Proximity to airstrips, LZs, or sea extraction points.

- Distance from population centers.

- Tactical and commercial communications capabilities.

- Provision of sufficient shelter for evacuees and US forces.

- Sustainability.

- Dependability.

Staff Planning Responsibilities

The *assistant chief of staff, G1*, coordinates with the evacuation ground forces S1 and division G3 to determine G1/AG support requirements. He—

- Prepares G1 portion of the staff estimate.

- Arranges the evacuation site.

- Establishes the processing center in the evacuation site.

- Prepares identification and evacuation log forms.

- Determines priorities for the evacuation based on guidance he receives from the Department of State.

- Briefs evacuees on evacuation procedures.

- Obtains or develops a health-risk analysis of the NEO area of operations.

- Briefs force on status of third country noncombatants seeking evacuation or refuge.

- Establishes provisions for handling women, infants, children, disabled, sick, and injured.

- Obtains and disseminates updated lists of evacuees.

- Establishes provisions for handling VIPs.

The *ACofS, G2*, defines essential elements of information; identifies official Department of State personnel, other Americans, and foreign nationals to evacuate; and identifies special needs of the evacuees. He also—

- Prepares G2 portion of staff estimate.

- Procures and distributes imagery, maps, city plans, and embassy building plans.

- Determines EEI.

- Coordinates for counterintelligence, prisoner of war interrogation (IPW), and linguist support.

- Identifies routes to assembly areas and evacuation sites.

- Conducts IPB, including analysis of the AO and physical layout of the embassy.

- Defines the capability and reliability of HN forces.

- Provides counterintelligence support.

- Screens and debriefs the evacuees.

In coordination with the G3, the G2 also revalidates and recommends changes to the existing EEP based on the current situation and his area analysis.

The *ACofS, G3*, plans the overall NEO effort, obtains the authority to establish liaison with the US embassy at both the evacuation site and the ISB, and plans the advance party. He also—

- Procures and reviews CINC CONPLAN for NEO area of operations.

- Procures and reviews EEP.

- Prepares G3 portion of staff estimate.

- Based on METT-T, requests additional assets beyond the capability of the division (for example, armored personnel carriers).

- Clearly defines chain of command and command relationships above division level.

- Obtains or develops ROE for the operation.

- Facilitates the conduct of rehearsals.

- Selects primary and alternate objectives, assembly areas, evacuation routes, and the evacuation site.

- Determines C² arrangements, procedures, facilities, and equipment.

- Defines parameters for the use of riot control agents, based on directives from the ambassador and the CINC.

The *ACofS, G4*, prepares the G4 portion of the staff estimate. He identifies the HN logistics support available, especially materiel handling equipment, transportation, and shelter. He also—

- Obtains local purchase authority.

- Ensures contracting officer and or purchasing officer is assigned to the NEO force.

- Ensures adequate funds in local currency are available to meet local procurement requirements.

- Determines requirements for procurement of subsistence and water.

The *ACofS, G5*, determines the requirements of civil affairs units and personnel. He coordinates procurement of supply and services with the evacuation ground force procurement officer, and coordinates evacuation planning with the HN and the US Agency for International Development. He also—

- Prepares G5 portion of staff estimate.

- Advises the commander on all civil-military and PA matters.

- Determines and disseminates command guidance on the release of information.

- Coordinates evacuation planning with HN officials.

The *division surgeon* conducts medical mission analysis with the evacuation ground force

senior medical officer, and coordinates with the G2 for medical information on the evacuees. He also—

- Determines the need for veterinary personnel, based on source of subsistence.

- ŽIdentifies and prepares for any special medical problems among evacuees.

- ŽCoordinates with HN medical facilities for assistance.

- ŽIdentifies from Department of Staff sources unauthorized drugs that evacuees may have.

- Ensures adequate HSS is available to support the force and evacuees.

- Identifies the need for preventive medicine personnel based on diseases among NEO population.

The *SJA* provides advice on international law issues, including—

- Political asylum.

- Foreign claims.

- ŽContract and fiscal law matters.

He serves as an escort and liaison, where appropriate, for members of the International Committee of the Red Cross in country. The *SJA* also maintains close and continuous coordination with the G5, G2, and provost marshal to ensure legal review and coordination of PSYOPS, intelligence collection, and security and maintenance of law and order among US forces and evacuees.

The *PMO* tailors *MP* forces to support the evacuation ground force; conducts circulation control operations; assists in processing, safeguarding, and evacuating *NEO* personnel; and plans traffic and crowd control procedures.

The *ADSO* determines the most effective communications with US embassy personnel, including HF frequencies and FM. He also—

- Prepares signal portion of staff estimate.

- ŽAnalyzes *CEOI* for joint and combined interoperability requirements.

- Develops coded execution checklists.

- Ensures that communications redundancy is achieved for each net.

- Obtains telephone listings for all persons and activities that may be needed during the operation (wardens, embassy, police, military).

The *PAO* determines the need for public affairs support in the *AO* and at the reception center, responds to all media queries based on the sensitivity of the mission and *OPSEC* considerations, and organizes a media pool with escort officer, if required.

The *division chaplain* determines the need for religious support for evacuees and coordinates for required religious services and pastoral care.

PEACEKEEPING OPERATIONS

Military peacekeeping operations support diplomatic efforts to achieve or maintain peace in areas of potential conflict. The UN has been the most frequent sponsor of peacekeeping operations. Historically, US Army battalion or brigade task forces have been involved in peacekeeping operations. However, divisions must be aware of the uniqueness of these types of operations. To be effective, the following conditions must be established for the peacekeeping force:

- Consent, cooperation, and support of the disputing parties.

- ŽPolitical recognition of the peacekeeping force by a portion of the international community.

- Clear rules of engagement.

- ŽSufficient freedom of movement for the force to conduct its mission.

- An effective *C²* system.

- ŽAn effective intelligence capability.

Peacekeeping often involves ambiguous situations requiring the peacekeeping force to deal with extreme tension and violence without becoming a participant. These operations follow diplomatic negotiations which establish the mandate for the peacekeeping force. The mandate describes the scope of the peacekeeping operations in detail. It typically determines the size and type of force each participating nation contributes. To ensure an effective peacekeeping operation, a mandate should have—

- Conditions the host nation intends to impose on the peacekeeping force.

Clear statements of the rights and immunities of individuals under jurisdiction of the international agency.

- Mission and tasks of the force.

Generally the UN categorizes its most likely operations as—

Buffer force. An interstate operation that keeps two military forces apart within a state while negotiations for an armistice are in progress. This type of operation requires patrolling and observation to detect infiltration by both parties.

Border patrol. Forces that patrol and intervene to prevent the outbreak of hostilities. These missions are directed to supervise ceasefire and the integrity of armistice lines.

Observation. Concerned with the supervision of armistice lines and truce and ceasefire agreements. The role is normally a static one based on a network of OPs. Units report any incidents which may lead to ground fighting or artillery exchanges and to monitor subsequent ground and aerial combat.

The task organization of the peacekeeping force depends on the following factors:

- The mandate.

The mission.

Type of conflict.

- Terrain.

- National acceptability by the host country.

When the peacekeeping force operates under the auspices of the United Nations, the Security Council is responsible to set size and composition parameters in cooperation of the UN staff, nations contributing troops, the force commander, and the respective host nations. Staffing of the force or mission headquarters can be effected by either using the principle of a broad geographical representation or by inviting contributing nations to share staffing responsibilities. *The design of the force is primarily responsive to factors other than normal military considerations (METT- T-P).* Additionally, UN forces have a civilian administrative staff assigned to deal with specific UN procedures.

During peacekeeping operations, it is not uncommon for the peacekeeping force to deploy on

the territory of more than one nation to perform its mission. Consequently, it will frequently find itself involved on several levels in the mediation of disputes. A peacekeeping force usually has little planning time. The tempo and outcome of diplomatic activity to effect and maintain a ceasefire is unpredictable, and negotiations to constitute and insert the peacekeeping force may be going on simultaneously. In an area of conflict, forces must be self-sufficient initially. Forces must deploy with complete communications and LOGPACs. The peacekeeping force contingency plans for unexpected combat operations and the introduction of reinforcements.

Peacekeeping force headquarters performs functions similar to those of a division headquarters. However, contingent staff members and forces do exercise certain independence of action in domestic matters which have specific national impacts. It is accepted that national contingents, while obedient to peacekeeping operational requirements, are still subject to the policy and directives issued by their own national armed forces. The planning of a peacekeeping operation is similar to that of any joint or combined operation. However, advanced planning opportunities are rare.

PEACE ENFORCEMENT OPERATIONS

Successful peacekeeping operations set the stage for future political solutions in the form of diplomacy, mediation, negotiations, or other long-term peacemaking solutions. Military success in peacekeeping operations facilitates and supports peacemaking. Peacemaking is a diplomatic process of arranging an end to disputes and resolving the issues that led to conflict. Infantry divisions conducting peacekeeping operations contribute to diplomatic efforts by creating an environment for fostering peaceful solutions. Under ideal circumstances, peacekeeping operations and peacemaking efforts are concluded to the satisfaction of the belligerent.

Circumstances may arise leading to the deterioration of peacemaking and peacekeeping efforts. Peace enforcement may be required—

- When one or more parties, originally consenting to the peacekeeping operation, withdraw their consent.

ŽTo support diplomatic efforts to restore order between hostile and unconsenting factions.

- To coerce hostile factions through the use of force, or the threat of force.
- To separate warring factions.
- To establish conditions more conducive to diplomacy and civil order.

In peace enforcement, threat of force or actual use of force is used to coerce warring factions to end the violence. Neutrality is difficult to maintain. Infantry divisions conducting peace enforcement operations are prepared at all times to apply elements of combat power to restore order, separate warring factions, and return the environment to conditions more conducive to civil order and discipline.

CHAPTER 7
OTHER OPERATIONS

This chapter provides some examples and techniques for other division operations.

Section I. RELIEF IN PLACE

The infantry division may be directed to conduct a relief in place during the course of corps operations. A relief in place is a combat operation in which one unit replaces all or part of another unit in a combat area. It may serve one or more of the following purposes:

- To relieve a depleted unit in contact.
- To relieve units stressed by prolonged operation in adverse conditions.
- To rest a unit after extended periods in high MOPP levels.
- To decontaminate a unit or avoid excess radiation.

Secrecy and speed characterize this operation. Centralized planning by the division staff and decentralized execution by major subordinate commands are the key to its success.

Higher headquarters directs when and where to conduct the relief and establishes appropriate control measures. The division may be required to conduct a relief in place under enemy pressure or without enemy pressure.

A relief in place conducted without enemy pressure normally entails a one-for-one swap of like units and equipment from occupied positions. A relief in place is time-consuming and requires detailed coordination and supervision.

A relief in place conducted while a unit is under enemy pressure is even more difficult. The example which follows portrays a relief operation under enemy pressure.

Figure 7-1, page 7-2, shows the corps conducting defensive operations. One of the defending divisions is a severely attrited infantry division operating in an area of restrictive terrain. Enemy activity is heavy and an enemy attack is expected within 72 hours. The corps commander has decided to conduct a relief operation under

enemy pressure. The corps commander elects to use his reserve infantry division to relieve the depleted infantry division to strengthen the defense and defeat the enemy's attack.

MANEUVER

The division has the mission to conduct a relief in place and then a defense in sector. The division is to conduct the relief and establish a viable defense with as little disruption to the continuity of the corps' defense as possible. To achieve this, the division will move forward and occupy defensible terrain to the rear of the division to be relieved. In this way, the in-place division becomes a covering force, allowing the relieving division to establish its defensive plan and develop fighting positions. When defensive preparations are complete, the in-place division will withdraw through the relieving division's defenses and move to the rear to reconstitute.

Deep Operations

The corps will continue to conduct deep operations during the relief. Corps aims to disrupt the enemy uncommitted and reserve forces before they can engage the corps' FEBA divisions.

Close Operations

On receipt of the corps warning order, the division establishes communications and liaison with the defending division's main CP. The relieving division's TAC CP moves to collocate with the defending division's TAC CP. The TAC CP monitors the current situation and coordinates withdrawal procedures. The division cavalry squadron moves forward concurrently to reconnoiter routes to brigade tactical assembly areas (TAAs) and proposed battle positions. The cavalry squadron then continues forward to establish a screen to the rear of the defending division's battle positions.

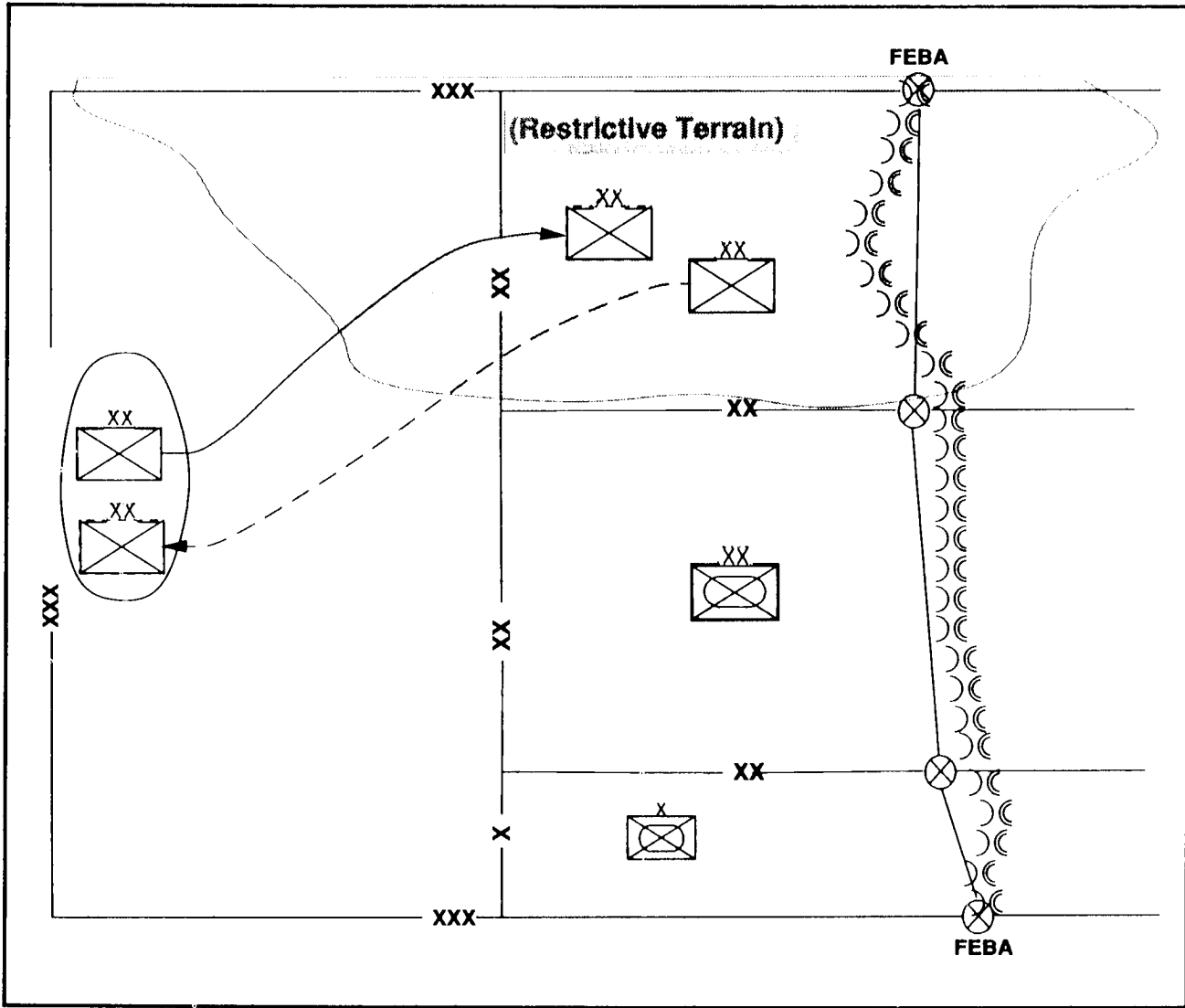

Figure 7-1. Relief in place: corps concept

The division main body (task-organized to conduct the defense mission) begins its move from the rear assembly area to the TAAs. (See Figure 7-2.) The main CP moves to the vicinity of the defending division main CP. The defending division comes under the TACON of the relieving division at a time mutually agreed on by the two commanders. This should occur early to facilitate the relieving division commander's planning for relief and defense. In this example, the relieving division assumes TACON when its brigades begin to move from rear assembly areas to TAAs.

The relieving division's maneuver- brigades then move forward to defensive battle positions behind the in-place division. The relieving division uses the in-place division's alternate and supplementary defensive positions to take advantage of any defensive preparations already begun.

The relieving division establishes its defensive positions while the relieved division continues to defend and acts as a covering force. Brigade advance parties coordinate procedures for the rearward passage of in-place units.

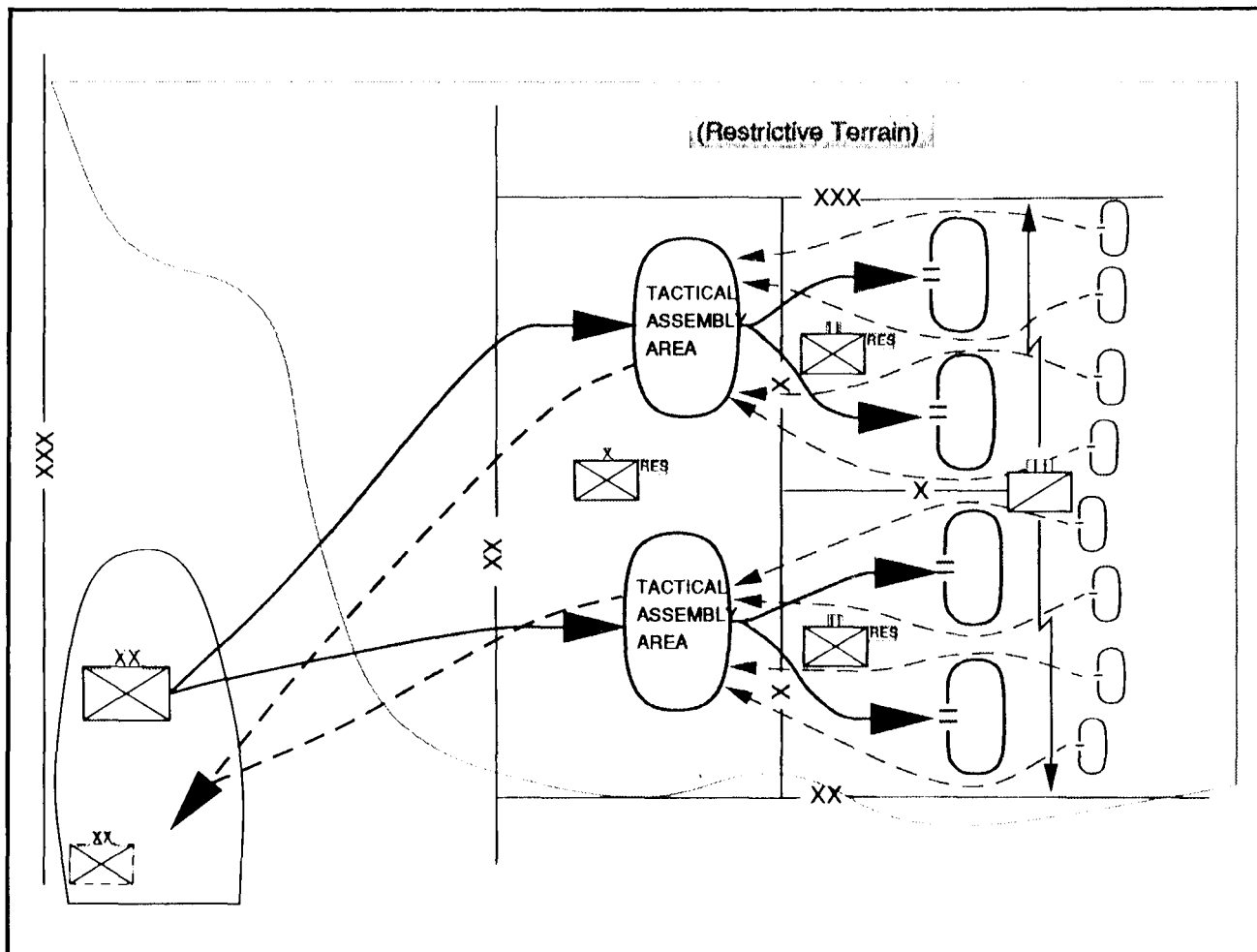

Figure 7-2. Relief in place: maneuver

On order, the in-place division begins withdrawing through the relieving division to move units to assembly areas. Relieved CS and CSS units assist both relieved and relieving units. The relieving brigades then defend in sector.

Rear Operations

The relieving division is responsible for all rear area functions. The division rear CP collocates in proximity to the in-place division's rear CP. A single traffic headquarters coordinates the movement into and out of the AO. Additional one-way MSR facilitates the forward and rearward movement of both units. The relieving division rear CP utilizes MPs from both divisions to control MSR from the DSA to the brigades TAAAs.

Security Operations

The relief in place is a tactically vulnerable operation. If the enemy becomes aware of the operation, it may attack the divisions. Conducting the operation under limited visibility reduces the possibility of detection. The divisions must give special attention and coordination to communications security in the preparation and conduct of the relief operation. The intent is for the enemy to perceive only one division C² structure in operation. Until the relief is complete, this should be the C² structure of the defending division. The relieving division should minimize radio communication to minimize its electronic signature. Collocation of CPs and detailed planning and

coordination are essential for portraying a single C² structure during the relief.

Reserve Operations

The relieving division designates an appropriate reserve for the conduct of the defensive mission based on factors of METT-T. In this example, the division has designated a brigade as reserve.

INTELLIGENCE

When the divisions receive their warning orders, the relieving G2 immediately establishes communications with the defending G2 to gain all current intelligence. The intelligence focus is to provide warning time for the division if the enemy discovers the relief before the brigades have completed their defensive positions.

The G2 collects and coordinates current intelligence with the in-place division. Based on recommendations from the G2, the commander establishes PIR for the relief operation and the conduct of the defense. The G2 plans NAIs, TAIs, and DPs and establishes a collection plan to support the commander's information requirements.

Based on the collection plan, the relieving division positions intelligence assets to support the plan. As relieving division assets move into place, they continue to receive information from the relieved division. The G2 and MI battalion commander select positions for assets to support the collection plan.

FIRE SUPPORT

Fire support assets from both divisions support the relief in place. Artillery focus is to position firepower for the defense and also to support the relieved unit. This is especially critical in the event the enemy detects the relief early and tries to exploit the weakness of the defending division.

At TACON, all relieved division FS assets come under the relieving division's control. Direct support artillery battalions move with their maneuver brigades. The relieving division positions corps FS assets from the in-place division to support the relieving division's defense. The relieving DIVARTY positions in-place and organic MLRS batteries to provide fires to support the counterbattery program. As the covering force

withdraws through the relieving units' defensive positions, the division FSE plans fires to deceive the enemy and expedite the passage of lines. Target acquisition assets from both divisions support the relieving division's defensive positions.

Fire coordination and control measures in front of the in-place division defensive positions remain in effect until withdrawal of the relieved unit. The relieving division coordinates and controls new and established fire control measures. The in-place division transfers critical ammunition (Copperhead and FASCAM) to the relieving division for redistribution.

The FSCoord for the relieving division meets the relieved FSCoord to exchange radio frequencies, secure devices, and target lists. They coordinate FS coordination measures that are in effect and the time the relieving division assumes FS responsibility. They designate artillery units from both forces to participate in the relief operations, and develop the fire support for the relief operations.

MOBILITY AND SURVIVABILITY

Initially, the division's priority is to get its brigades into sector, conduct the relief, and pass the relieved unit out of sector. Engineer priority in support of this will initially be mobility of routes and lanes within the sector in support of the relief. Once the relief is complete, priority of effort normally transitions to countermobility and survivability operations in support of the brigades.

AIR DEFENSE ARTILLERY

The in-place and relieving divisions' ADA elements coordinate and confirm enemy air avenues of approach into the AOs. Priority of effort is to protect passage points, battle positions, and assembly areas. Command and control of all ADA passes to the relieving division on assuming TACON.

COMBAT SERVICE SUPPORT

The division support area moves near the relieved unit's DSA. This enhances coordination of available stocks and supplies by both units. The relieving division's FSBs move forward to establish operations in brigade TAAs. As in-place FSBs

displace, they leave critical supplies such as ammunition and fuel with relieving FSBs. Additional haul capability augments the maneuver brigades to expedite front loading of class IV and V into battle positions. Both divisions preposition artillery ammunition for artillery units in preparation for the defensive battle. Patients of the relieving division are moved rearward by the relieved division.

COMMAND AND CONTROL

On receipt of the warning order, the relieving division TAC CP immediately moves forward to collocate with the in-place divisional TAC CP.

Section II. RETROGRADE OPERATIONS

The infantry division may have to disengage from an enemy force by conducting retrograde operations. Retrograde operations are conducted to—

- Preserve combat power by gaining time.
- Avoid combat under unfavorable conditions.

Ž Reposition forces to eliminate exposed flanks or shorten LOCs.

- Conform to other units' movement.

Ž Draw the enemy into an unfavorable position.

Ž Harass, exhaust, resist, delay, and damage the enemy.

- Clear areas for friendly use of nuclear or chemical fires.

The three types of retrograde operations are delays, withdrawals, and retirements. In a delay, a division under enemy pressure trades space for time, inflicting maximum damage while avoiding decisive engagement. A division in contact with the enemy conducts a withdrawal to break contact. In a retirement, a division not in contact moves away from the enemy.

In Figure 7-3, page 7-6, an infantry division has been conducting defensive operations as part of a corps defensive operation. The corps has been conducting a defense in sector with a mechanized division on the left and an infantry division on the right in an economy of force role. The infantry division sector is in restrictive terrain, and the division has successfully defended against enemy

The TAC's primary concern is getting the division into defensive positions and withdrawing the relieved division without the enemy discovering the operation.

The main CP locates near the relieved division's main CP. During the withdrawal, the defending division's main and TAC CPS relocate in the rear assembly area. The relieving division rear CP works closely with the relieved division rear CP to coordinate routes, priority of movement, and terrain for the withdrawing division and to ensure the movement of critical supplies for the defense.

attack. The enemy main effort has been against the mechanized division.

To preserve the fighting strength of both divisions and to reduce a developing exposed flank between them, the corps commander directs the divisions to withdraw to more defensible terrain along PL ALPHA. There the corps will reestablish defensive operations against the attacking enemy. The corps considers the limited mobility and firepower of the infantry division in determining the placement of the new defensive position.

The current tactical situation and intelligence reporting of the infantry division indicate--

Ž The division continues to maintain an effective capability to conduct close operations, but has limited ability to identify, locate, and engage deep targets.

- The enemy is not currently attempting to penetrate defensive positions in the division AOs, but continues to apply pressure through indirect fires and small-unit attacks.

MANEUVER

The infantry division commander's concept for the withdrawal involves organizing a covering force and a main body (Figure 7-4, page 7-7). The covering force mission is to prevent interference with the withdrawing main body and deceive the enemy as to the division's intent.

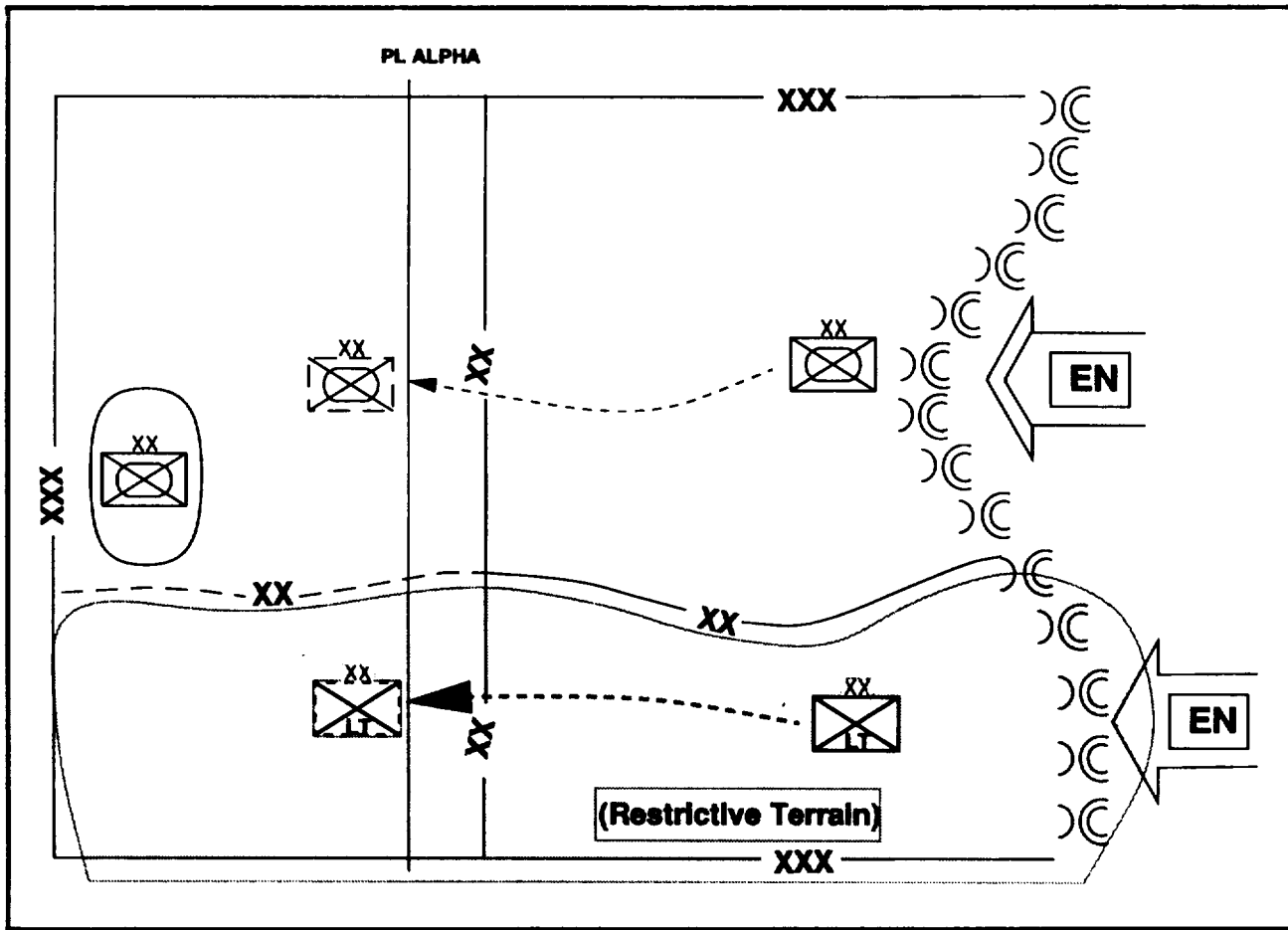

Figure 7-3. Retrograde operations: corps situation

In this example, the covering force is task-organized as shown in Figure 7-5. All other units remain as task-organized from the defense mission.

Deep Operations

The corps continues to conduct deep operations to support withdrawing forces. The intent of the corps deep operation is to create conditions under which the divisions can withdraw while avoiding decisive combat under unfavorable conditions. Enemy forces must be prevented from exploiting the opportunity presented by withdrawing friendly forces.

Close Operations

In this example, the infantry division covering force is a composite organization with three maneuver battalions and an OPCON attack

helicopter battalion (AHB) under a brigade headquarters. The three battalions come from the three brigades in contact, rather than all from one brigade, to minimize movement across the defensive front.

The covering force simulates normal activity to deceive the enemy, and protect the withdrawal of the main body to the rear. Covering force units continue aggressive patrolling, normal radio traffic, and vehicle movement. The covering force is prepared to fight a delay to permit withdrawal of the main body. The AHB uses its mobility to make limited objective spoiling attacks to disrupt enemy offensive operations, enabling the withdrawal to proceed with minimum interference.

Units forming the division main body retire by stealth to designated assembly areas (AAs) behind the covering force. From AAs, they move on

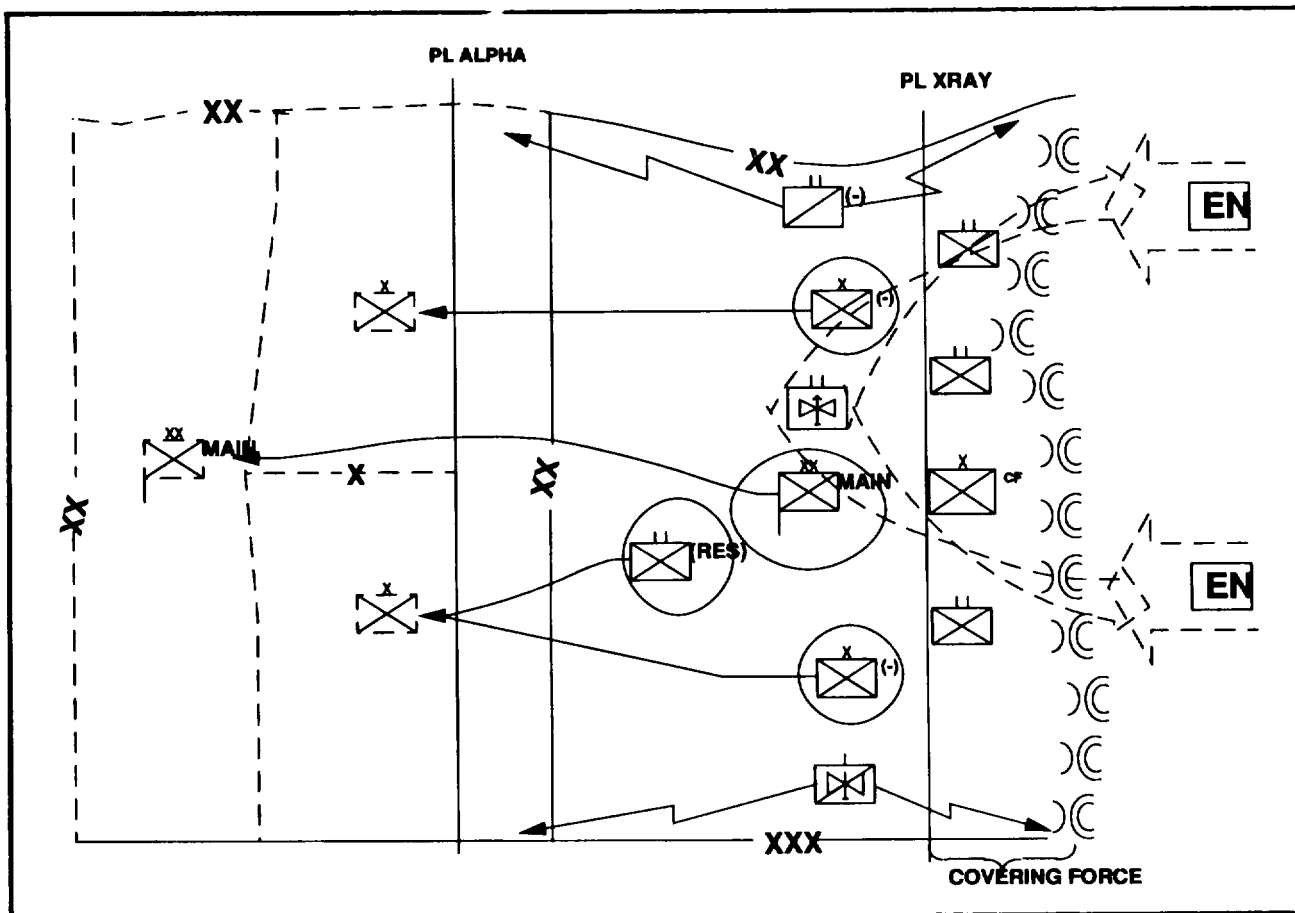

Figure 7-4. Retrograde operations: division maneuver

designated routes to PL ALPHA and begin preparing positions to resume the defense. The division uses air and ground transportation (division assets and corps augmentation) as much as possible to speed the withdrawal while maintaining secrecy. The division controls movement of withdrawing units by designating priorities, times, and routes of withdrawal from AAs. The withdrawal sequence is—

- Combat service support units.
- Field artillery not in support of the covering force.
- Main body.
- Covering force.

The withdrawal is normally conducted at night. The withdrawal plan includes deception, integrated with the corps' deception plan, to

portray the division continuing the defense in current positions. The withdrawal plan also includes contingency plans for the covering force or main body to delay or defend short of PL ALPHA.

— Bde HHC	— Engr Co (Lt)
— Inf Bn	— Cbt Engr Co (OPCON)
— Inf Bn	— Cml Co (Smk/Decon)
— Inf Bn	— (-) (DS)
— Atk Hel Bn (OPCON)	— ADA Btry (DS)
— FA Bn (105T) (DS)	— MI Co Tm (DS)
— FA Bn (105T) (R)	
— FA Btry (155T) (R)	

Figure 7-5. Retrograde operations: task organization

The covering force withdraws on order by conducting a series of delays after the main body has disengaged, or at a predesignated time and place. If the deception has been successful, the covering

force may remain in position, delaying its withdrawal to prolong the deception. When the covering force has withdrawn, it conducts a rearward passage of lines through the new defensive positions, and moves to a designated reserve position. The withdrawal of the covering force must be synchronized with the withdrawal of the adjacent division's covering force. This will minimize the possibility of creating a gap between the divisions which could be exploited by the enemy. Since there is a significant mobility differential between the two covering forces, synchronizing the withdrawal will be critical.

Rear Operations

Combat service support elements displace early, leaving only those elements necessary to support the main body withdrawal and the covering force fight. Units already in the rear move to new positions during the conduct of routine operations. Military police conduct reconnaissance of withdrawal routes and establish TCPs as required to control movement. Established MSR are primary avenues for withdrawing division elements.

Security Operations

The cavalry squadron screens the flanks for the covering force, maintaining contact with adjacent forces during the withdrawal. This will prevent the creation of gaps between defending friendly forces.

Reserve Operations

Normally, no division reserve is designated for the withdrawal, although brigades may designate reserves. The battalion initially designated as the division reserve is attached to a brigade and moves during the withdrawal to PL ALPHA to establish the new defense. After the covering force conducts a rearward passage of lines, it moves to an assembly area and assumes the mission of division reserve.

INTELLIGENCE

On receipt of the warning order to withdraw, the G2 directs an update of the IPB and recommends new PIR to the commander. The IPB identifies NAIs, TAIs, DPs, and a series of delay

positions that maximize the natural defensive value of available terrain. The G2 focuses his efforts initially on monitoring indicators that provide warning for the commander that the enemy has discovered the withdrawal before it is complete. The G2 adjusts collection and R&S plans as needed. The G2 also provides intelligence updates to the covering force S2.

The G2 ensures that division intelligence asset coverage includes both covering force and new defensive position requirements. Division-controlled EW assets are well forward to support the covering force fight and the deception plan. These include the Teammate AN/TRQ-32 and AN/TRQ-30 for communications intercept and direction finding. The G2 plans Quickfix for collection and jamming.

Prior to the withdrawal, several LRS teams were positioned to remain as stay-behind elements. REMBASS sensor strings were also positioned on avenues of approach into the division sector, and along potential parallel flanking routes. Together, these assets assist in targeting for the main body withdrawal and the covering force. They facilitate the defense and future offensive operations. Information from LRS teams and in-place sensors goes directly to the covering force S2. All other MI assets are used for defensive operations at PL ALPHA. The G2 coordinates with flanking units and corps for additional intelligence and sensor coverage.

FIRE SUPPORT

Fire support assets provide an essential combat multiplier to augment the limited maneuver assets of the division covering force. Two FA battalions (105-millimeter) and the 155-millimeter battery provide support to the covering force. One 105-millimeter battalion is in direct support, and the other battalion and the battery reinforce the DS artillery battalion. The division's remaining 105-millimeter battalion and corps FS assets support the division as the main body withdraws.

The covering force FSE plans and coordinates fires to support the battle. Should the enemy attack before the withdrawal is complete, the FSE employs FS assets to slow the enemy's advance, cover obstacles with fire, support spoiling attacks,

and provide final protective fires. The FSE masses fires to help extricate threatened or isolated units. Smoke is also planned to mask the movement of friendly forces. FASCAM is planned along enemy avenues of approach into the division sector and used if needed to assist the covering force in withdrawal.

The corps smoke and decontamination company provides smoke support along withdrawal routes and flanks, and in assembly areas. Covering force DS and reinforcing artillery displace by echelon. The division FSE coordinates with corps for fires for the displacement, including TACAIR and GS reinforcing artillery.

Air Force CAS supports the withdrawal and aids the covering force in both fighting and disengaging from the enemy. It supports limited objective counterattacks and provides the covering force commander responsive air support to influence close operations. The division also plans for the use of ECM to deceive the enemy, and disrupt his C², thus slowing his reactions to the withdrawal.

MOBILITY AND SURVIVABILITY

The priority of engineer work is to countermobility at the new defensive positions. Disengaged engineer assets conduct countermobility and survivability actions as they withdraw. They prepare point obstacle targets (road craters and abatis) behind the covering force to support the withdrawal. Corps smoke assets provide smoke support to the obstacle emplacement. Engineers also prepare successive hasty firing positions for covering force artillery as it withdraws. They maintain routes to the rear to aid the withdrawal.

Covering force engineers include an attached light engineer company, and an OPCON combat engineer company from corps. Their priority of work is to mobility for the withdrawal, and countermobility to close prepared obstacles as the covering force delays to the rear.

AIR DEFENSE ARTILLERY

The ADA battalion provides area protection to support withdrawal of the main body and covering force. In this example, the ADA battalion provides a DS Stinger battery to the covering force. Remaining ADA assets are in GS to the main body, placed within the main body, along routes of withdrawal, on choke points, or in areas where enemy air attack could slow or stop movement. The ADA battalion coordinates coverage with corps and adjacent divisions to ensure continuity of ADA protection.

COMBAT SERVICE SUPPORT

Priority of CSS is class V and medical evacuation support to the covering force. Division and brigade CSS elements displace to the rear before combat elements begin withdrawal. Recovery equipment is positioned at critical locations along withdrawal routes to keep routes open and recover all possible equipment.

To the extent possible, the division evacuates command-controlled items and destroys other supplies and equipment (except medical) which cannot be withdrawn. Wounded personnel are evacuated as early as possible. The division prepositions class V supplies for the covering force at intermediate firing positions.

COMMAND AND CONTROL

The TAC CP remains forward to control and support the covering force. The main CP commands and controls the withdrawal of forces not in contact. It displaces by echelon with the main body, supports the withdrawal, and plans and manages actions necessary to resume the defense. It synchronizes corps and divisional assets, including FS, ADA, engineer, and smoke support. The rear CP displaces to the rear early in the withdrawal. It manages terrain and controls movement in the division rear and behind PL ALPHA. The division exchanges liaison personnel with corps headquarters and flank units to maintain synchronization.

Section III. FORWARD PASSAGE OF LINES

During tactical operations, the infantry division may be required to conduct a forward passage of lines through another division. The division will normally conduct this passage through another unit to perform an infiltration, exploit tactical success, or serve as a corps counterattack force. The passage of lines is an operation designed to facilitate another tactical operation. The division's task organization must support the primary tactical mission. A passage of lines is characterized by centralized planning and execution.

The division normally uses multiple passage lanes through a defending unit. This technique supports decentralized movement of units and the division's capability to infiltrate and remain undetected. In-place unit assets support the passage.

This section describes a technique for passing a division through another division by using passage lanes. Control measures for this operation are restrictive and hamper maneuver if the enemy attacks. The forward passage of lines places both passing and in-place divisions in danger while both occupy the same terrain. A forward passage should be rapid to minimize this vulnerability.

In Figure 7-6, a mechanized infantry division has conducted an attack that has caused the enemy force to withdraw. The mechanized division has maintained pressure on the enemy and pushed him into restrictive terrain where he has established a hasty defense. Due to the terrain, the corps orders the mechanized division to establish a hasty defense. It orders the infantry division, which is behind the mechanized division, to pass through the mechanized division and attack to clear the enemy in zone through the restrictive terrain. The mechanized division will support the passage and prepare to continue the attack. The infantry division has moved to tactical assembly areas to the rear of the mechanized division. Current intelligence reporting indicates the enemy has reconnaissance elements in contact with the defending mechanized division and expects reinforcing units within 48 hours.

MANEUVER

Prior to the corps warning order directing the passage, the infantry division was in a TAA. On receipt of the warning order, the division begins coordination and reconnaissance, while division units conduct troop-leading procedures and preparation for movement and combat.

To coordinate the passage, the infantry division collocates its TAC CP with the mechanized division TAC CP. If possible, TAC CPs physically connect to each other to aid in exchange of information. The divisions exchange information on the enemy situation, friendly dispositions, terrain analysis, and fire and obstacle plans. They develop the overall passage plan, including security measures to use during the passage. The TAC CPs also coordinate for infantry brigade TAC CPs to collocate with mechanized brigade CPs.

The infantry division cavalry squadron conducts initial reconnaissance of brigade attack positions behind the mechanized division positions. It conducts reconnaissance of routes from the division assembly area to the attack positions and from attack positions to passage lanes.

The infantry division main CP and maneuver brigades plan and coordinate the overall operation, emphasizing the attack on restrictive terrain. The infantry brigades send teams to link-up points to coordinate with their mechanized brigade counterparts for the passage.

The mechanized division continues to conduct counterreconnaissance operations throughout its defense. These operations should not be significantly increased just prior to the passage, as this may alert the enemy to the passage of lines.

At the corps-directed start point time, the cavalry squadron conducts zone reconnaissance forward of release points and establishes a screen forward of the division. Infantry brigades move from the division assembly area to designated attack positions where they make final preparations for the passage and the attack (Figure 7-7, page 7-12). Mechanized division units clear obstacles and guide the infantry units through the

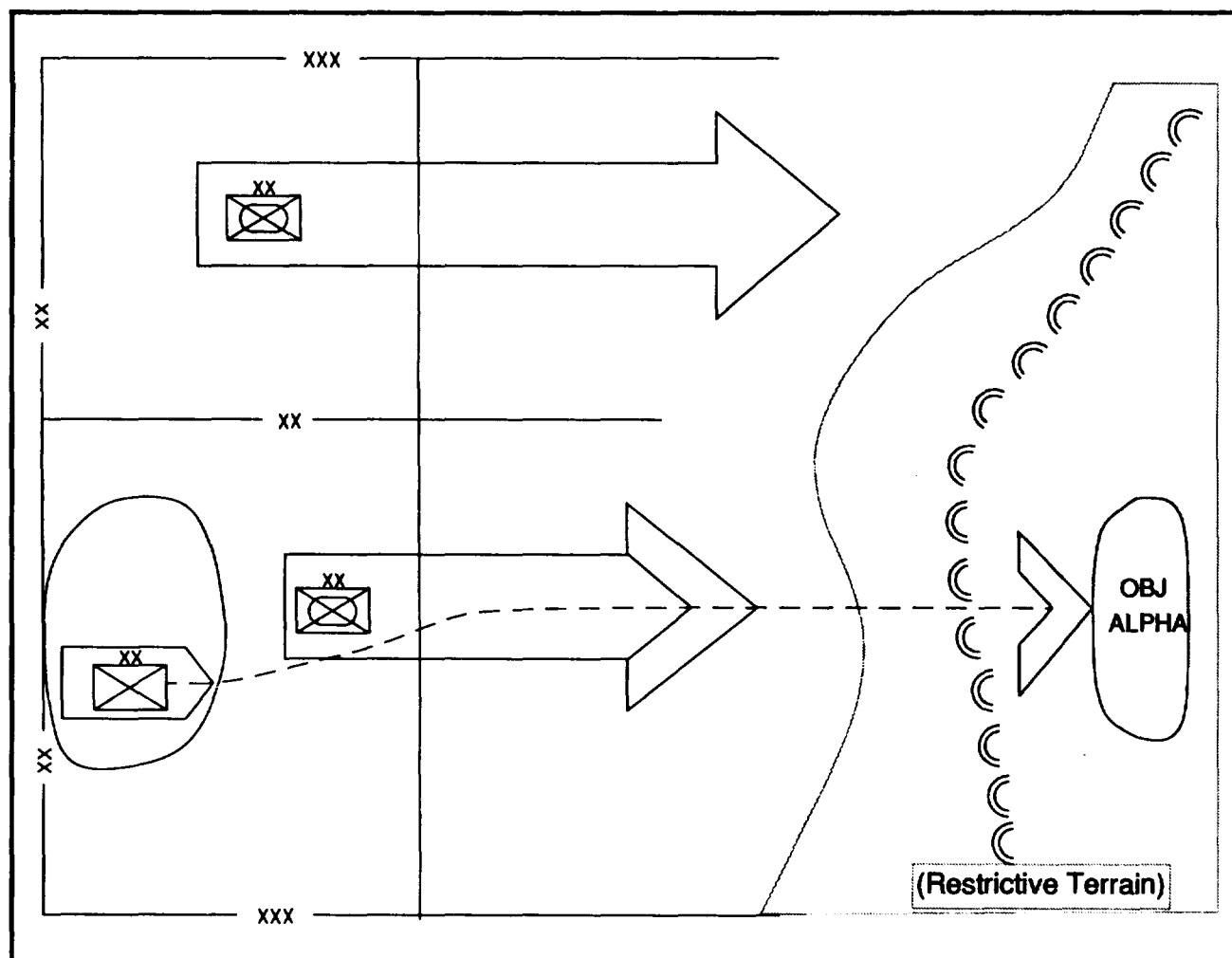

Figure 7-6 Forward passage: corps situation

passage lanes. The brigades move quickly from attack positions, breaking down into smaller units to move through passage lanes, and then continue the offensive operation. The mechanized division maintains the security of passage lanes and continues the defense.

INTELLIGENCE

The infantry division receives current intelligence information from the mechanized division, corps, adjacent divisions, and lower units. Both divisions coordinate reconnaissance efforts to target enemy elements in front of the passage area. The infantry division's intelligence assets are task-organized primarily to support the offensive operation following the passage.

FIRE SUPPORT

Fire support assets of the in-place division provide fire support until the passing unit is out of range. Prior to the passage of lines, FS elements at both division TAC CPS plan for massed, coordinated fires throughout the AO. Both divisions plan CAS and AI to support the passage and attack. The mechanized division provides radar support. Once the infantry division passes the line of departure, it initiates and clears calls for indirect fire forward of the LD.

MOBILITY AND SURVIVABILITY

In-place division engineer assets provide support to prepare and execute the passage. Priority

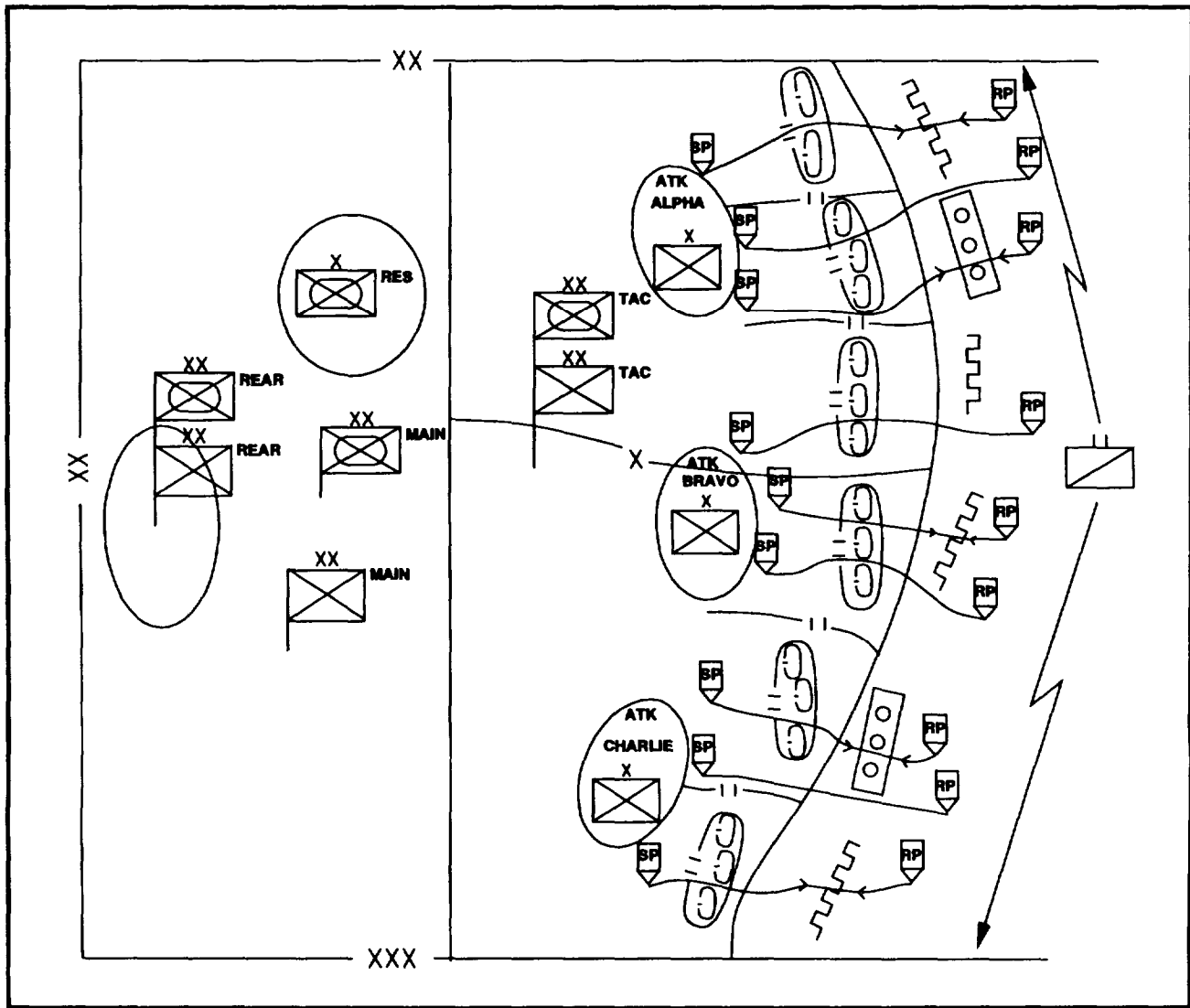

Figure 7-7. Forward passage: maneuver

of effort is mobility of the passing unit through the passage lanes and obstacles. The TAC CPs analyze in-place unit obstacles and barriers for synchronization with the passage plan and to support the attack. In-place division engineers plan FASCAM to protect passing and in-place units from enemy counterattacks.

AIR DEFENSE ARTILLERY

The infantry division conducts the passage under mechanized division and corps ADA coverage. The infantry division coordinates ADA coverage with adjacent units. During the passage, ADA assets of the mechanized division provide

area support while passing division ADA assets provide DS to moving units. The ADA priority is to units moving through passage lanes. During movement through the passage lanes, passing unit ADA status is tight, then weapons free at the LD.

COMBAT SERVICE SUPPORT

The infantry division's CSS assets locate in the mechanized division's AO as far forward as possible to support both the passage and subsequent attack. The mechanized division assists the infantry division with maintenance areas, water points, and HHS and support facilities.

COMMAND AND CONTROL

The infantry division TAC CP collocates with the mechanized division TAC CP when the divisions receive the corps warning order. Both divisions coordinate control measures to support the passage of lines. They establish the time for the passage and identify the routes, attack positions, link-up points, and start and release points through the passage lanes. The TAC CPS coordinate call signs, frequencies, and recognition signals to use during the passage. Infantry division units monitor the frequencies of the mechanized division. The mechanized division maintains normal radio communication during the passage, while passing units maintain radio listening silence.

The TAC CPs coordinate the passage of command during the passage of lines. The mechanized division maintains command of its units throughout the passage. If a battle develops during the passage, the mechanized division controls the battle from the collocated TAC CPs. The infantry division TAC CP monitors and controls the division passage of lines. The TAC CP passes through the lines as soon as possible after the maneuver brigades complete their passage and follows the main effort. The infantry division normally assumes control of the zone forward of the LD after its first maneuver battalion and brigade CP clear the passage lanes. The mechanized division supports the infantry division with direct and indirect fires as long as possible.

Section IV. LINK-UP OPERATIONS

The division plans, coordinates, and synchronizes link-up operations to join other US, allied, and or indigenous forces. Forces may be moving toward each other, or one may be stationary. The division conducts link-up operations—

- To complete encirclement or envelopment of an enemy force.
- To assist in the breakout of an encircled friendly force.
- To join an attacking force with a force inserted in the enemy rear.

A linkup may be part of an offensive or defensive operation.

In Figure 7-8, an infantry division has conducted a supporting attack by infiltration and air assault into the enemy rear. Its mission is to seize key terrain and disrupt enemy C² and logistics in support of a corps attack conducted by a mechanized infantry division. The mechanized division has attacked through the enemy defenses and is moving to link up with the infantry division and pass through it. Following linkup, the mechanized infantry division will continue the attack and the infantry division will conduct follow and support operations. The division tactical situation and intelligence reporting indicate that—

- The corps is attacking a depleted enemy force. The enemy is having difficulty maintaining a coherent defense due to the corps' coordinated attack.

- Enemy supporting fires are lessening in intensity and friendly forces have air superiority. The enemy can counterattack with up to a regimental-sized force.

The corps order designates control measures for the linkup. Corps establishes phase lines (PL FAR, PL MIDDLE, PL NEAR, PL CLOSE, and PL AWAY) and fire control measures, including FSCLs and a RFL. The mechanized division establishes CFLs. (See Figure 7-10, page 7-16 and Figure 7-11, page 7-17, for fire control measures.) Corps designates link-up points or units coordinate their link-up points with corps approval. The infantry division, as the stationary force, designates and coordinates primary and alternate link-up points on the boundary where the forces will meet. Link-up points should be on identifiable and defensible terrain which provides escape routes. The corps order also designates the command relationship for linkup. When the mechanized division reaches PL NEAR, it assumes TACON of the infantry division until it has passed PL AWAY.

The two divisions exchange as much information as possible prior to the tactical operation. Representatives meet to coordinate—

- Command relationships before, during, and after the linkup.
- Fire support.

ŽThe implementation of control measures.

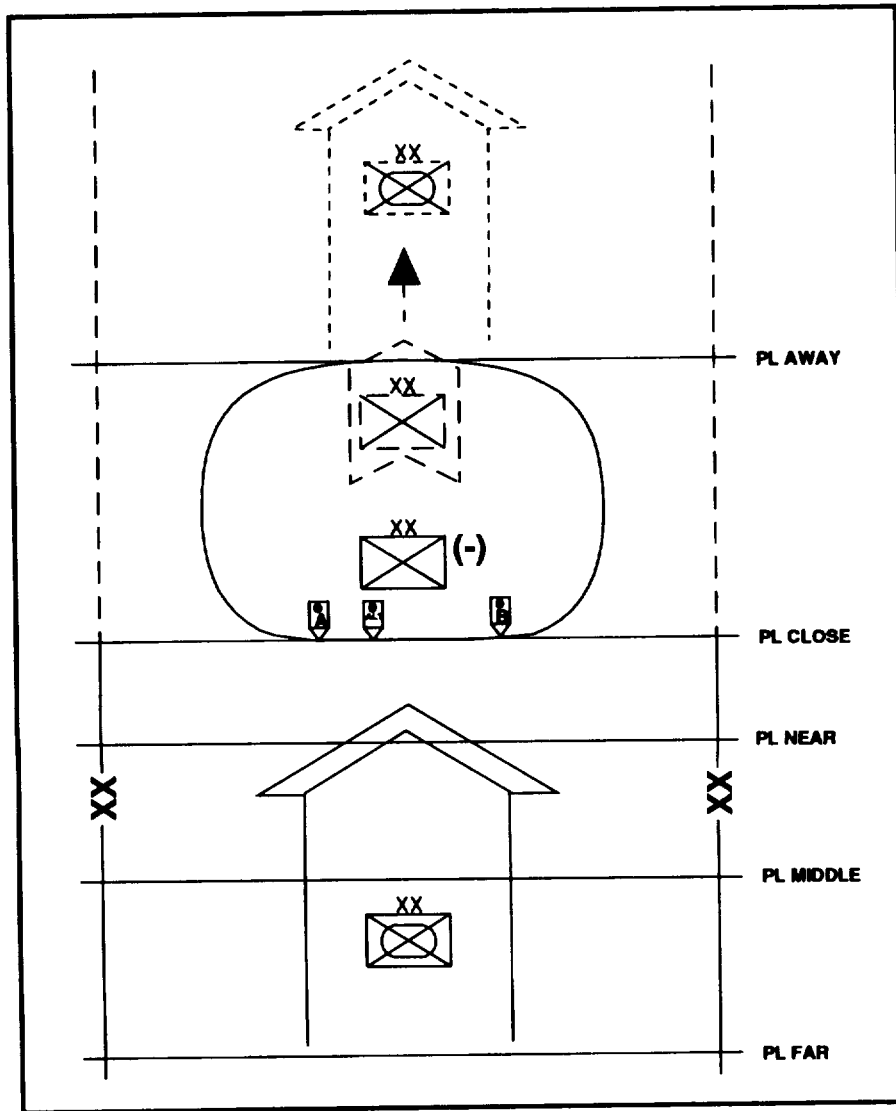

Figure 7-8. Link-up operations: corps situation

- Planned routes to link-up points.
- The location and description of primary and alternate link-up points.
- Recognition signals and communication procedures.
- Exchange of liaison personnel.

MANEUVER

The division must coordinate, synchronize, and execute the linkup concurrently with other operations without losing momentum. The division's primary mission is to seize key terrain to

expedite and facilitate the forward passage of the corps main attack. Following linkup, the infantry division passes the mechanized division through its sector and reorients for its follow and support mission behind the advancing mechanized division. The linkup is not the primary mission of either division, but is critical to the overall success of the corps operation.

Prior to the infiltration, the infantry division commander designates one brigade to coordinate and conduct the linkup. The division authorizes the brigade to coordinate directly with the

mechanized division's cavalry squadron, its designated link-up unit. Units should—

- Exchange liaison personnel.
- Coordinate communications.
- Exchange SOIs.

Ž Verify day and night and near and far recognition signals.

Ž Provide their division the specifics of the link-up plans.

- Coordinate fires, intelligence, and obstacles.

As the mechanized division reaches PL MIDDLE (Figure 7-9), its cavalry squadron moves to link-up points and initiates linkup with the infantry brigade.

The infantry brigade expedites the passage of lines by opening lanes or corridors, breaching selected obstacles, and furnishing guides. The mechanized division completes the passage and moves toward the corps objective while the infantry division secures the corps LOC. Both divisions are prepared to conduct a hasty defense at any point throughout linkup, passage, and subsequent operations.

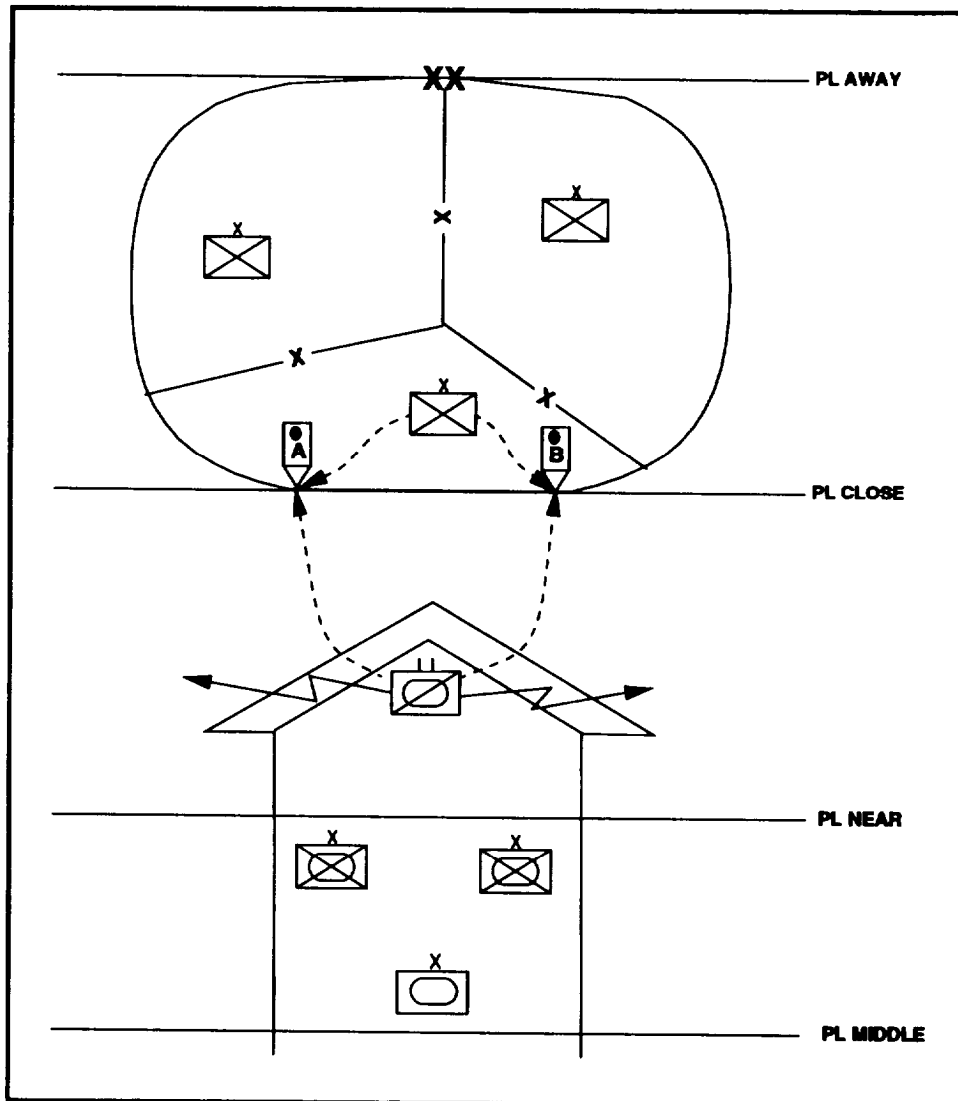

Figure 7-9. Link-up operations: maneuver

INTELLIGENCE

To support the linkup, the division G2 employs sensors near link-up points to identify enemy movement toward the division's position. Both divisions and corps must closely coordinate EW plans to preclude interference as the mechanized division converges with the infantry division.

FIRE SUPPORT

Fire support coordination measures are critical to the linkup of converging forces. In this example, as the mechanized division moves closer to the link-up points, both divisions increase positive fire control to avoid firing on each other. The mechanized division establishes an initial coordinated fire line, CFL 1. As it reaches PL FAR, it

terminates CFL 1 and puts CFL 2 into effect. (Figure 7-10.) The mechanized division coordinates the CFLs with the infantry division to control infantry division fires in the direction of the mechanized division.

As the mechanized division reaches PL NEAR, the corps establishes a RFL at the boundary between the two divisions. The mechanized division terminates CFL 2 and establishes CFL 3, which includes both division areas (Figure 7-11).

MOBILITY AND SURVIVABILITY

The infantry division and its engineers coordinate with the mechanized division before emplacing obstacles between PL CLOSE and the infantry division boundary in case maneuver

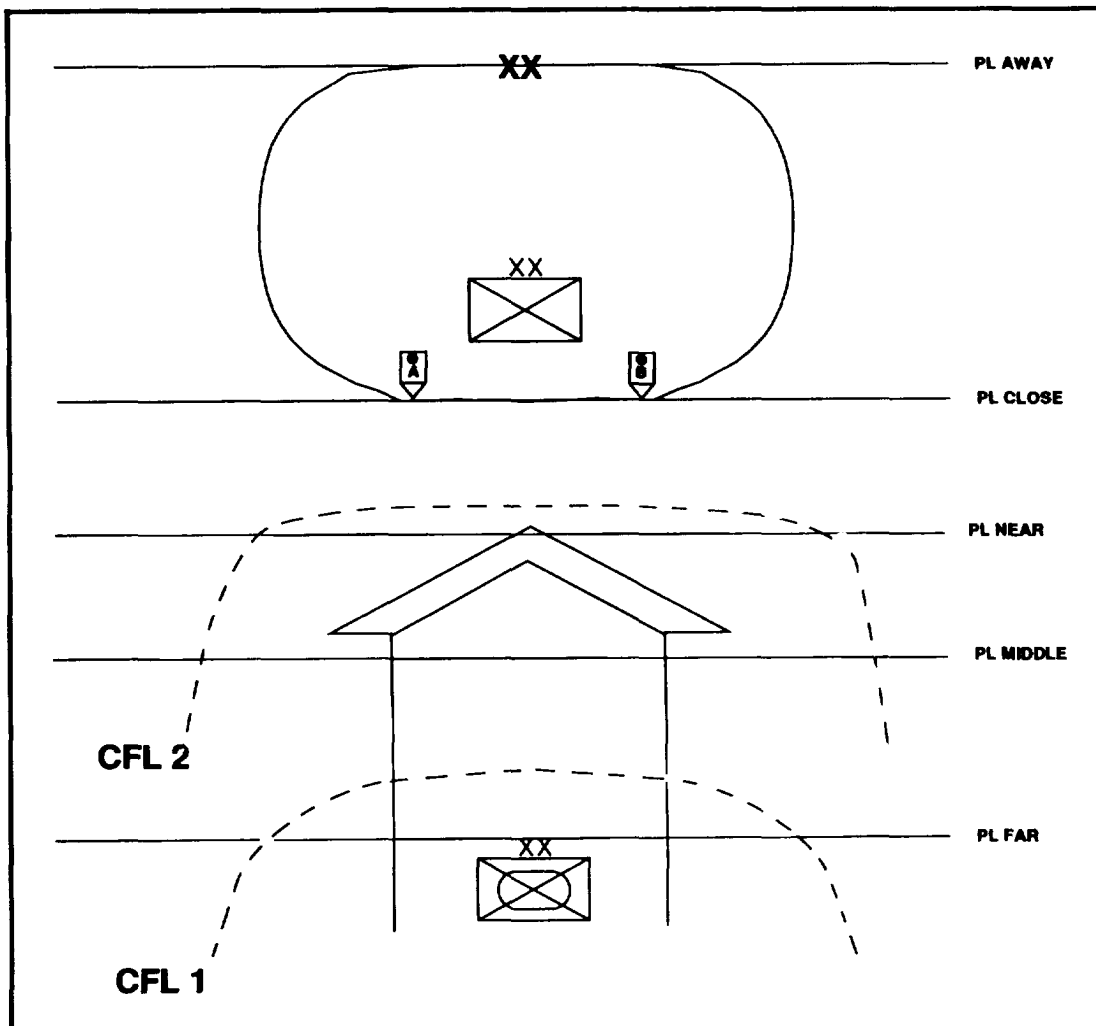

Figure 7-10. Link-up operations: fire support

within this area becomes necessary. Based on METT-T, the division engineer may plan obstacle zones on enemy avenues of approach into the division sector. These obstacle zones include the full spectrum of obstacles to include conventional and scatterable mine systems.

AIR DEFENSE ARTILLERY

Corps establishes ADA coordination and restrictive fire measures by phase line as the divisions converge. The converging ADA systems must coordinate identification requirements and cover the gap between forces. On linkup, both divisions must coordinate ADA coverage for area protection.

COMMAND AND CONTROL

The divisions integrate the coordination and planning for the linkup into their planning for the offensive operation. The corps order established the command relationships, control measures, and responsibilities between the link-up units. The mechanized division commander assumes TACON of the infantry division when the mechanized division crosses PL MIDDLE.

Following successful linkup of the converging forces, the link-up operation becomes a passage of lines for the mechanized division. The specifics of this critical operation must be equally well planned to provide for the continuous protection of both forces.

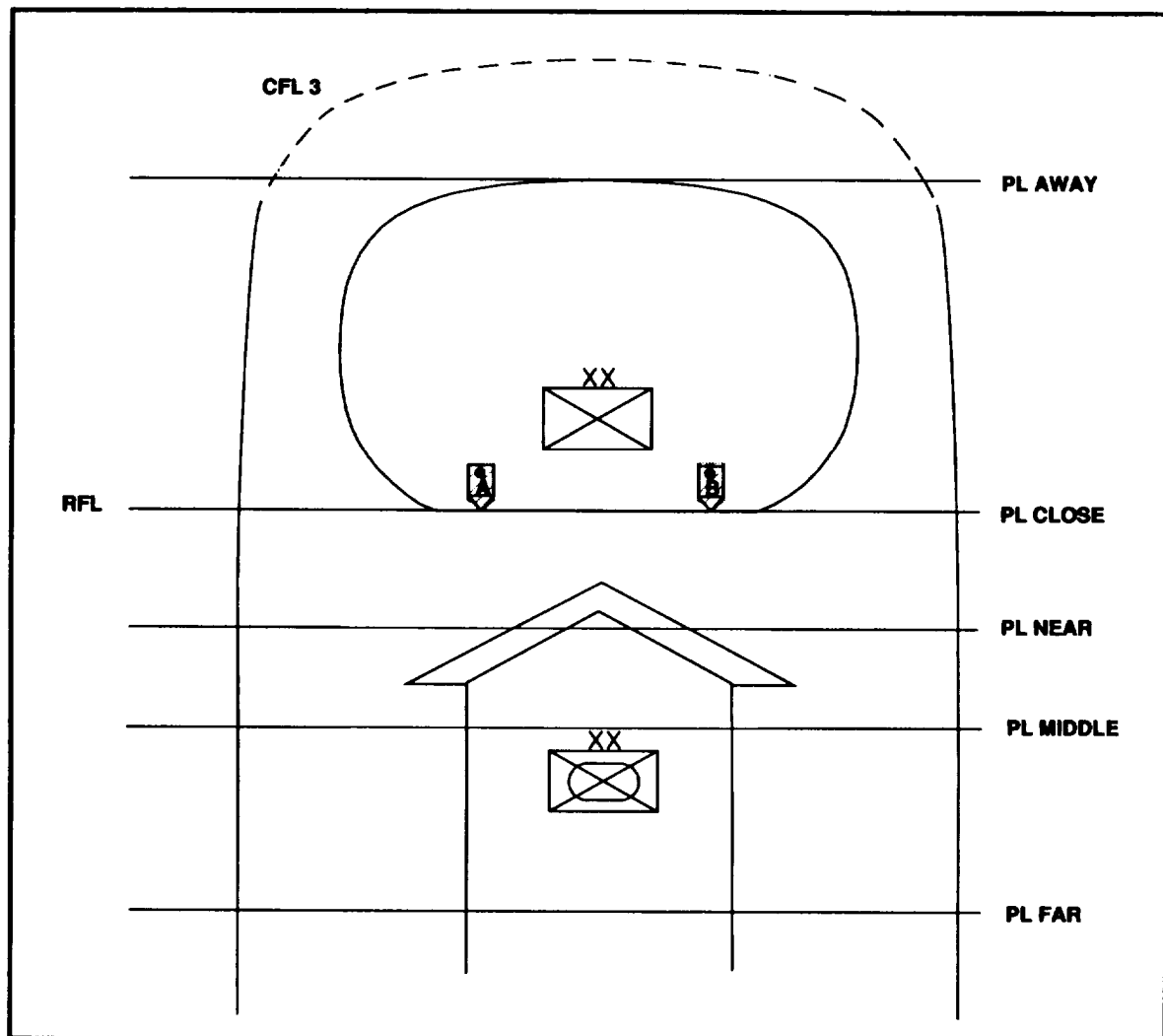

Figure 7-11. Link-up operations fire support (continued)

Section V. BREAKOUT FROM ENCIRCLEMENT

Due to the nonlinear nature of the modern battlefield, the division may have to fight while encircled. The division may be encircled by design, as in an infiltration, or by circumstances of battle, such as holding key terrain, defending a strongpoint, conducting an attack, or holding the shoulder of friendly or enemy penetrations. Encirclement occurs when the division's ground routes of evacuation and reinforcement are cut off by the enemy.

Combat operations for an encircled division are difficult. The division may respond to encirclement in several ways. First, it can stay in position and defend. It may be able to inflict damage on the enemy, divert an enemy attack, restrict enemy maneuver and logistics support, acquire intelligence, or even capture objectives to support other operations. However, the effect on the enemy may be limited and the division may lose combat effectiveness or be destroyed.

Second, the division can attack to break out of the encirclement and link up with friendly forces. This may allow it to support a corps deception plan, interfere with enemy command and control, or allow it to be used elsewhere. However, the division may link up in a depleted condition and be of no use until it is reconstituted.

Third, the division can exfiltrate by small groups. This is the least preferred option, but it is preferable to capture and may divert the enemy's attention and provide intelligence for higher headquarters.

The division's response to encirclement will depend on the situation and intent of the higher commander. Corps (or the division commander when communications are disrupted) must make an early decision as to the encircled division's mission and objectives.

In the situation depicted in Figure 7-12, the division was defending in restrictive terrain as an economy of force operation for the corps. Enemy maneuver elements have bypassed division defensive positions and pushed back other corps elements. Enemy infantry have cut division ground routes of evacuation and reinforcement. The encirclement contains most division maneuver, CS, and CSS units.

The corps commander has directed the division to conduct a breakout from encirclement and link up with other corps forces. This will keep the division as an intact maneuver unit for future corps operations. The division must plan, organize, and execute a breakout from encirclement with available forces before the enemy has time to analyze intelligence information and react by reinforcing the encirclement and perhaps taking away the breakout option.

Current division tactical situation and intelligence reporting indicate the enemy has employed minimum combat and CS forces to fix the division, indicating he may not know his force has encircled the division. The enemy has allocated insufficient forces to encircle the division completely, and gaps currently exist in the encirclement. Further, they indicate—

- The enemy is moving forces to reinforce his operation. Enemy reconnaissance elements are actively conducting reconnaissance and surveillance operations.
- The division can communicate with higher and lower units. Weather is marginal, but allows use of Air Force and attack helicopter assets.
- The corps will conduct a supporting attack in conjunction with the division breakout.

MANEUVER

The division commander's concept is for the division to attack as soon as possible by employing a force to infiltrate enemy positions and attack to create a rupture (Figure 7-13, page 7-20). The remainder of the division defends the perimeter during the rupture, then fights a combination delaying action and withdrawal from the perimeter through the rupture (Figure 7-14, page 7-21). The division continues the attack through the enemy to link up with other corps assets.

While planning for the breakout, the division continues to defend on the most defensible terrain, holding the entire perimeter. It may reduce the size of its perimeter to maintain a strong defense; however, it must maintain room for maneuver. The division employs reconnaissance elements to determine enemy strength and weaknesses near the planned breakout point. It conducts counterreconnaissance operations to

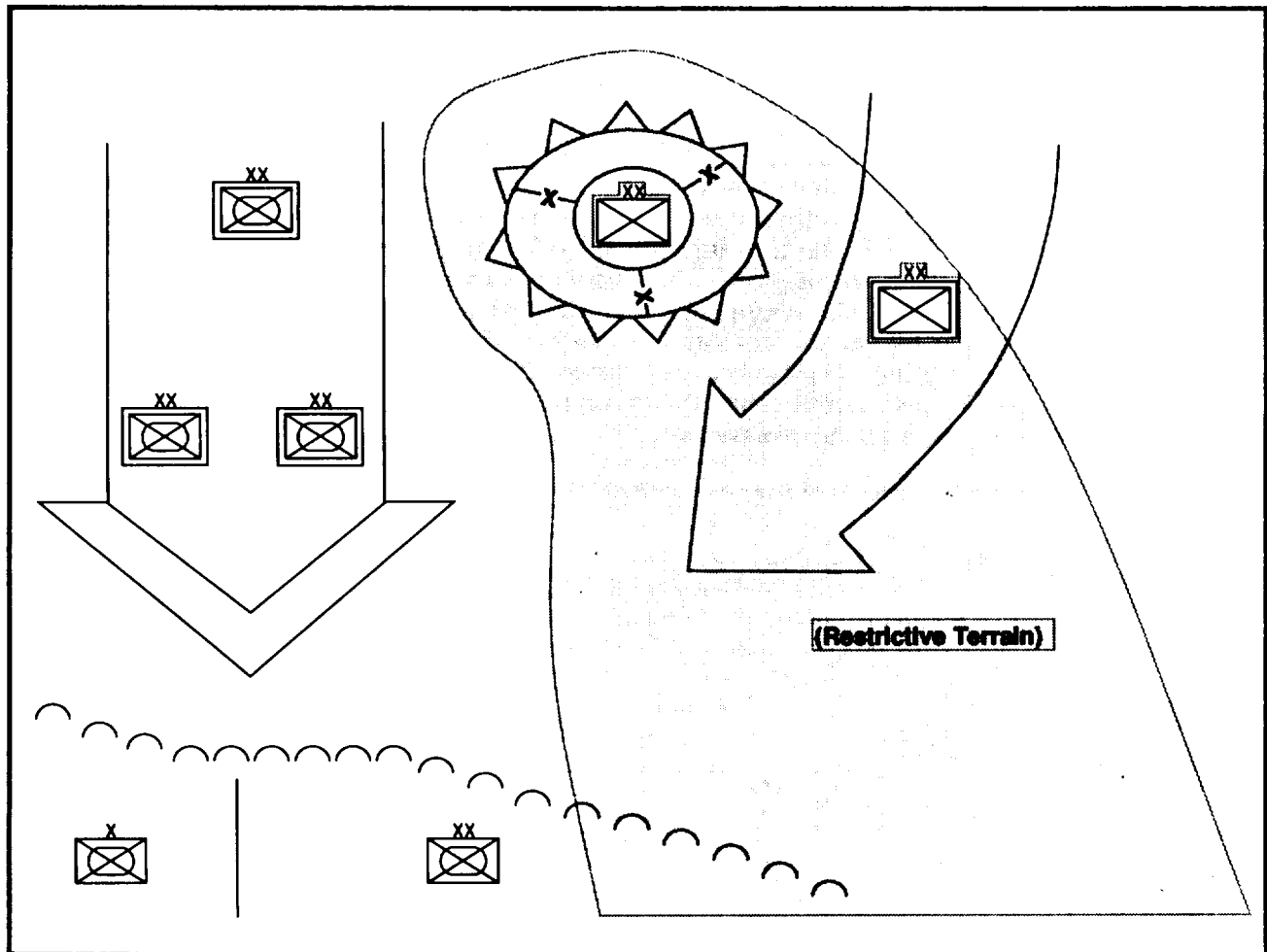

Figure 7-12. Breakout from encirclement: corps concept of the operation

deny the enemy information on friendly breakout plans.

The division selects the rupture location and routes of march that avoid enemy strengths, increasing the chance for surprise. The route selected may not be direct; it may be over less favorable terrain. The division avoids the most obvious route toward friendly lines unless there is no alternative. However, the division may use the most obvious route for a diversionary attack.

The division coordinates with corps for supporting attacks by other available corps forces to support the breakout. Link-up points are coordinated prior to the breakout or during the breakout by lead or security elements. If possible, the aviation brigade is evacuated to the corps rear early. If it is still a viable force, it is used to

support during the breakout and movement to linkup. The division plans for and, if available, employs TACAIR support for the breakout operation. If it has sufficient forces, the division organizes a diversionary attack before the real breakout attempt.

The division uses the task organization shown in Figure 7-15, page 7-21, for the breakout.

Deep Operations

The division relies primarily on corps artillery and aviation assets to conduct its deep operations. When possible, the division attacks enemy uncommitted forces and rear installations to disrupt enemy operations. The corps must prevent enemy reinforcements from linking up with enemy encircling forces or attacking into the flanks of the division as it breaks out.

Close Operations

A rupture force, a two-battalion infantry brigade, infiltrates enemy defenses. It attacks enemy positions, creating and widening a gap, and holds the shoulders of the gap until all encircled forces have moved through. An assault force follows the rupture force and moves through the gap to continue the attack to the link-up point. The main body, comprising the remaining combat forces, CP elements, and CS and CSS elements, follows the assault force. The rear guard provides security, following and protecting the main body. The division must mass overwhelming combat power to generate momentum at the breakout

point. It takes risks on other parts of its perimeter to ensure success of the breakout. If the division does not maintain the momentum of the breakout attack, it will be more vulnerable to destruction than before.

Breakout forces use all routes available. The breakout plan should exploit darkness and limited visibility, if possible. However, the division should not wait for conditions of reduced visibility if this allows the enemy to consolidate or reinforce the containment. If available, smoke from the corps chemical company conceals the breakout operation, or supports a deception plan.

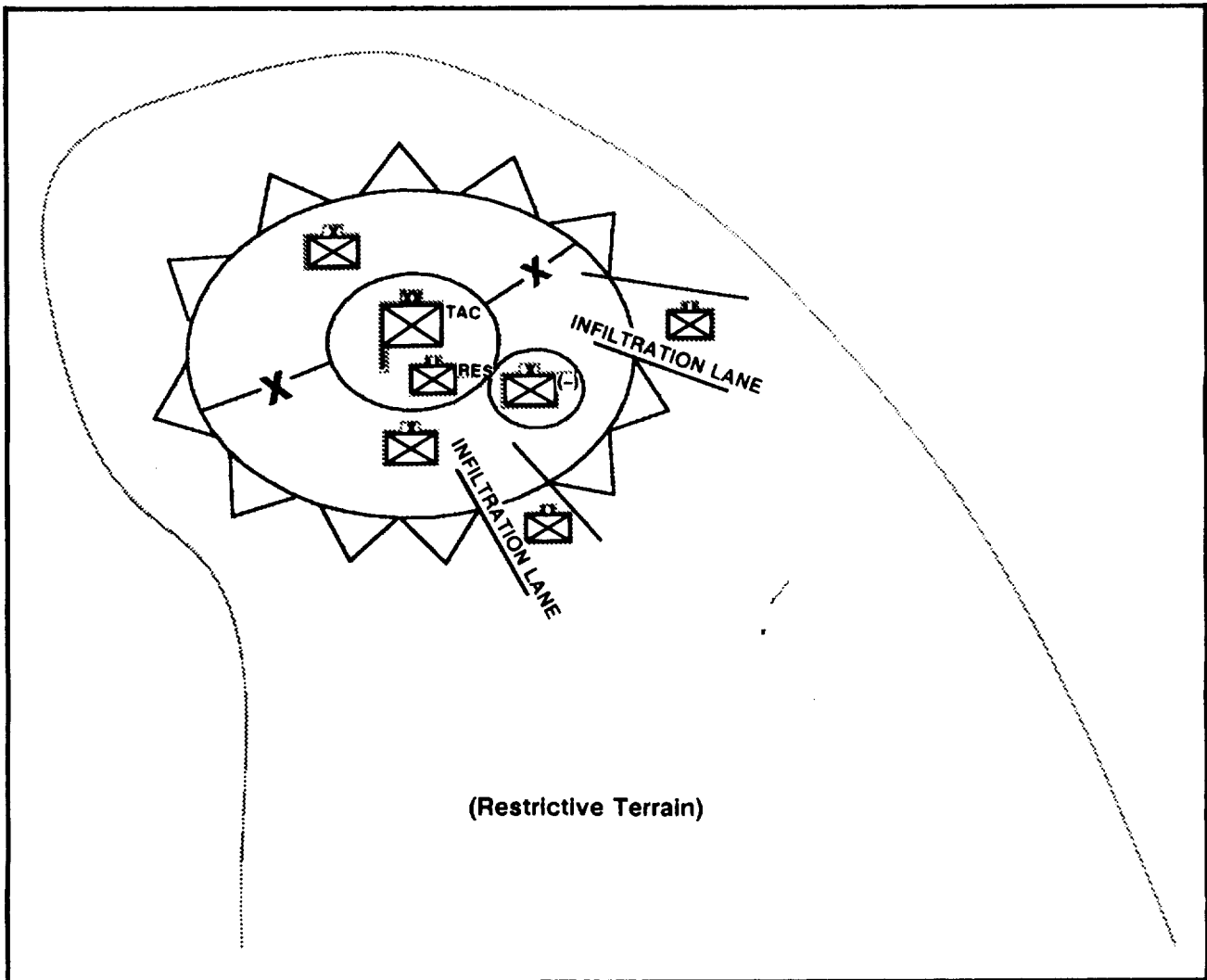

Figure 7-13. Breakout from encirclement: maneuver

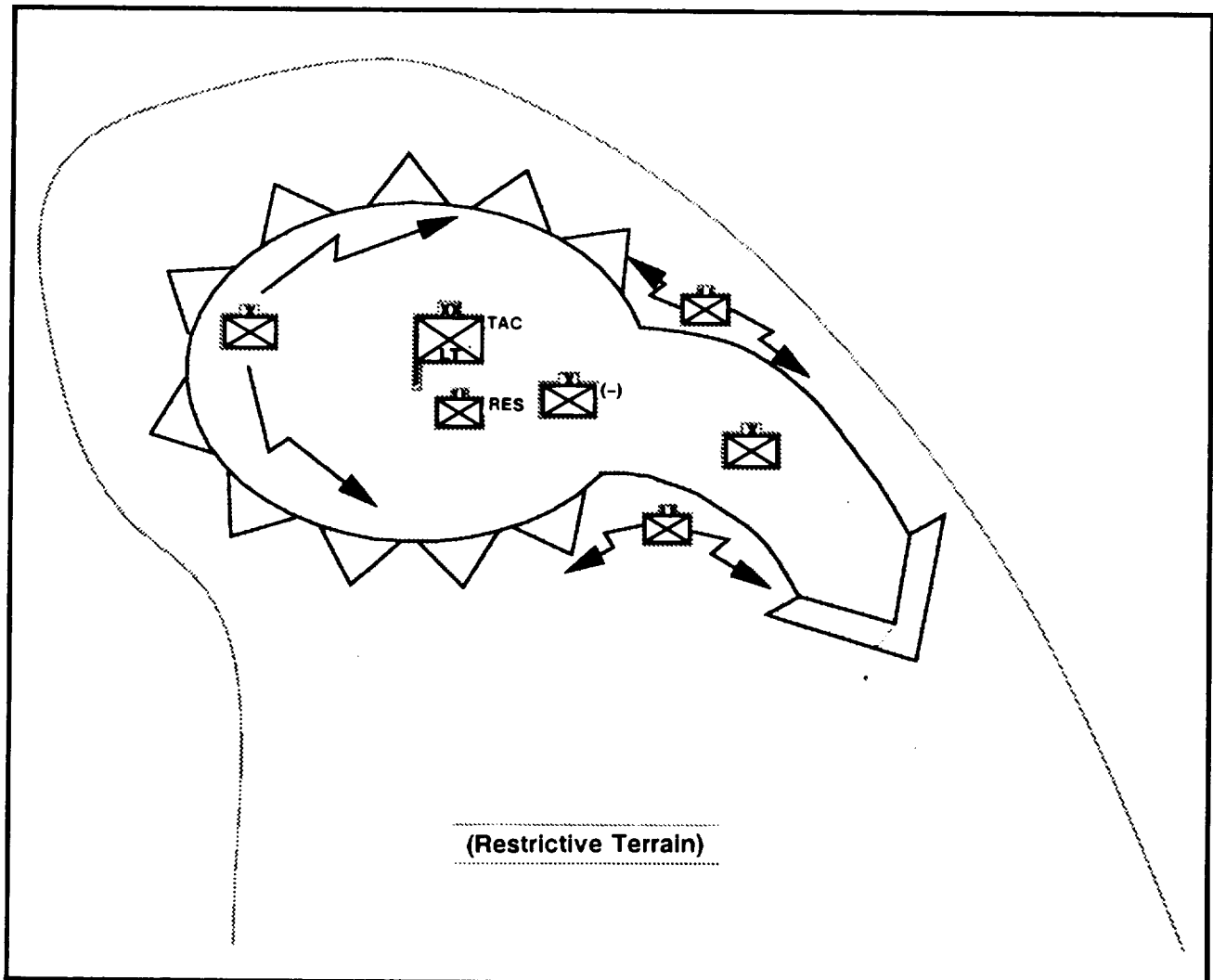

Figure 7-14. Breakout from encirclement: maneuver (continued)

Rear Operations

The division's CS and CSS elements that did not evacuate earlier are integrated throughout the main body for protection during the movement.

Security Operations

Main body elements provide flank security. The rear guard must fight a vigorous delaying action on the perimeter to ensure no part of the division is cut off. The rear guard disengages from the defense and passes through the rupture. The rupture force secures the penetration until passage of the rear guard. Then it disengages and assumes the rear guard mission.

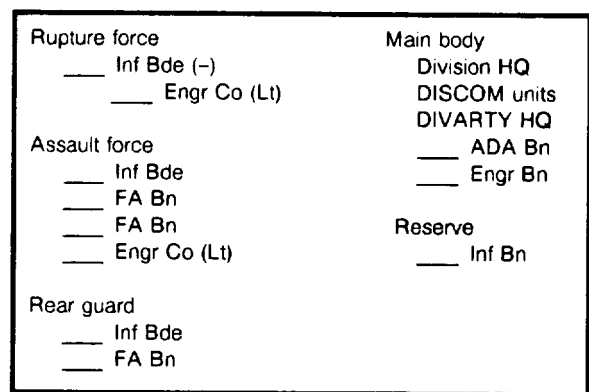

Figure 7-15. Breakout from encirclement task organization

Reserve Operations

The division designates an infantry battalion as reserve for the breakout. The reserve is initially in the center of the encirclement to react quickly to a penetration at any point in the perimeter. It then moves with the main body through the rupture.

INTELLIGENCE

The G2 selects break-out points that exploit gaps or weaknesses in the enemy encirclement. The G2 employs all available intelligence assets to obtain current information on enemy strengths, dispositions, and intentions around the division and especially between the encircled division and friendly forces. The G2 determines potential break-out points based on both terrain and weaknesses in the enemy encirclement. Long-range surveillance teams infiltrate to specified NAIs before the breakout to expedite operations. All encircled units conduct counter-reconnaissance to mask friendly intentions and actions.

FIRE SUPPORT

Fire support assets must react to rapidly changing conditions in the encirclement. They must support the defense, breakout, rear guard operations, and movement to link up. The division brings all artillery within the encirclement under centralized control. Field artillery battalions may continue to provide support to brigades, but must be responsive to division requirements. The division establishes on-order missions to maximize firepower at critical times. The division establishes fire support execution matrixes for key events such as breakout and disengagement fires.

In the initial defense, the division positions artillery to allow rapid shifts of fire and direct support for large parts of the defensive perimeter without displacing to new positions. Artillery is distributed throughout the encirclement to limit its vulnerability to counterfires.

During the breakout, the division employs massed, continuous fires to open the rupture point, suppress enemy direct fire systems, and isolate the breakout from the enemy. Once

the rupture is achieved, priority of fires may shift to the rear guard action if sufficient fires are available to support the momentum of the breakout. Field artillery assets provide continuous fire support to each breakout force during the breakout and subsequent movement to link up with friendly forces.

The division coordinates fire support from outside the encirclement. It establishes a RFL around the encircled forces and then a series of CFLs as it moves toward linkup. The division coordinates offensive nonlethal EW to disrupt enemy communications during the breakout. The division plans disengagement fires for the rear guard; TACAIR support and Army aviation assets support the disengagement.

MOBILITY AND SURVIVABILITY

The priority of engineer work is mobility, then countermobility. Engineer assets focus their efforts on breaching operations. The division engineer plans situational obstacle zones to support the operation. Engineers are task-organized as obstacle breaching teams under the control of maneuver units. Engineers support the rear guard by emplacing obstacles as the defensive perimeter is reduced. Engineers with the rear guard close obstacles.

AIR DEFENSE ARTILLERY

Divisional ADA elements protect key assets according to priorities developed by the ADA commander and G3 and approved by the division commander. Priorities for breakout include fire support assets and aviation support areas. Within these specific priorities, an ADA battery provides direct support to the rupture force. A gun platoon and a Stinger section provide direct support to the rear guard. The ADA employment plan complements SEAD operations in support of the breakout.

COMBAT SERVICE SUPPORT

As soon as encirclement by the enemy appears inevitable, the division uses open LOCs to evacuate casualties and all nonessential staff, combat support, and combat service support personnel and equipment. The division places

organic and supporting encircled CSS assets under centralized control. When required, elements of CS and CSS units can increase the strength of the division's fighting units.

Division dead that cannot be evacuated before encirclement are buried in hasty, properly marked graves. Wounded soldiers have priority on transportation assets. If they cannot be moved, critically wounded soldiers are left behind with limited medical personnel, supplies, and equipment.

The division breaks out with only those items of equipment and supplies that are essential to the mission and that it can transport on available vehicles. Units destroy all weapons and equipment (less medical) that cannot be fully manned or supported.

Military police enforce traffic control within the defensive perimeter to ensure order and discipline, and prevent panic. Strict rationing and supply economy conserve limited resources and combat power. The division distributes class III and V supplies weighted to the priority of effort. CSS assets are integrated into the main body for movement.

COMMAND AND CONTROL

The commander directs subordinate commanders to reestablish or reinforce the chain of

command as necessary before the breakout operation and to reorganize to form tactically strong units. If possible, the division coordinates before the breakout for linkup and passage through friendly elements. It maintains liaison and coordination with higher and lower headquarters. The division establishes control measures (phase lines) to control movement and hand over rear guard responsibilities to the rupture force.

The TAC CP is positioned behind the assault forces. Remaining elements of the rear and main CPs collocate within the main body.

The commander must recognize the importance of morale and the potential for despair by encircled soldiers. Soldiers must have trust in the competence of their leadership. The commander should—

• Disseminate information quickly throughout the command.

- Ensure command presence at decisive points.

- Ensure that an effective casualty evacuation system is in place.

Encircled forces will likely suffer significant casualties and loss of equipment while encircled, during breakout, and during movement toward friendly forces. Detailed planning and swift, violent execution can minimize these losses.

Section VI. INFILTRATION

Infiltration is the "jewel in the crown" of infantry operations. It includes the most demanding of tasks and requires expert terrain skills, teamwork, and discipline. Fire support and control in an infiltration is extremely complex and difficult.

It is highly unlikely that an infantry brigade can infiltrate a structured defense (for example, a reconnaissance and security zone with multiple defensive belts) and hide itself over several nights. The norm is to infiltrate one night and attack targets the next day or night.

Infiltrations cannot be done on too large a scale. The largest infiltration unit should be brigade (rarely occurs); the smallest, a platoon; optimum may be a company.

Infiltration can be a valuable offensive capability in support of tactical operations. Infiltra-

tion can be employed in support of deception, guerrilla tactics, and intelligence collection, or to posture a unit for an attack.

Infiltration moves forces through an enemy-held area to a position of advantage in the enemy's rear. From there, the force uses other forms of maneuver to attack its assigned objective.

Infiltration differs from a penetration. In the penetration, maximum combat power is exerted to pass through an enemy defense. In an infiltration, infiltrating units seek to avoid enemy defenses and pass through gaps in the defense. Units are then postured to attack LOCs, support units, installations, or other objectives in the rear of the forward defense areas, or to seize key terrain to facilitate other operations.

They may also infiltrate to conduct raids, block or control key communications nets, destroy bridges, effect barriers, harass enemy logistics operations, conduct feints or demonstrations for deception, or engage in any of a number of intelligence collection activities. Infiltrating forces may be used to provide accurate target information or an eyes-on targeting capability.

PHASES

The division normally conducts infiltrations in three phases. First, aggressive patrolling is used to find gaps in the enemy's forward defense. The second phase is the actual infiltration through the enemy's forward defensive areas. Phase three is assembly in attack positions in the enemy's rear.

Characteristics of terrain and nature of the conflict influence the use of infiltration. Infiltration maybe favored when—

- Enemy maneuver forces are dispersed. Dispersion allows passage of the infiltrating force through the resulting gaps.

ŽThe enemy cannot easily mass against the infiltrating force without endangering his own forces.

- Seizure or neutralization of objectives in the enemy's rear is critical.

ŽTerrain provides infiltrating forces relative protection from detection and destruction.

PREREQUISITES FOR SUCCESSFUL OPERATIONS

Planning

The first prerequisite to a successful infiltration mission is a detailed plan based on mission analysis and estimates of the situation. Infiltration has the best chance for success when enemy defenses are overextended. The commander and staff select objectives and routes based on terrain analysis, enemy dispositions, and need to avoid engagement before reaching attack positions. Best results may be achieved when infiltrating forces attack simultaneously with or soon after other attacking forces.

Initiative

Successful infiltrations are characterized by boldness and initiative. This does not equate to

recklessness. Individual and small-unit resourcefulness and ingenuity are required to prevent enemy detection.

Tactical Movement Proficiency

Proficiency in tactical movement is a requirement for successful infiltration. It provides the ability to find routes which permit the force to bypass enemy positions. The key to success is to locate gaps in the enemy surveillance capability.

Physical Conditioning

During the infiltration, the infiltrating force must carry its own logistics support. The requirement to carry several days' supplies plus fighting equipment means soldiers must be physically tough to carry heavy loads over long distances and difficult terrain. Ammunition and class I are the primary items of soldier load during infiltrations. The individual soldier's combat load must be reduced to a minimum. Ponchos and liners or insulated tops and bottoms may be sufficient to ward off the effects of the environment for the time of the infiltration.

Security

Successful infiltration operations are best accomplished during periods of limited visibility. If the enemy has electronic detection devices, electronic countermeasures must be used to neutralize this detection capability.

Patrols can provide security during the infiltration and may prevent enemy reconnaissance from determining the size of the infiltration and its objectives. Supporting artillery fires can be used to target known enemy locations and to mask the movement of infiltrating forces.

Time

Infiltrations in strength or to deep objectives must be allocated sufficient time to accomplish movement. This is critical when the infiltration is synchronized with another attack.

Size

The size of the infiltrating force is METT-T dependent. Infiltrations are normally accomplished by platoons, and companies. Once gaps in enemy defensive positions are located by patrolling units, these locations can be pinpointed with

the GPS. This can allow infiltration by larger units by using way points programmed into the GPS. The largest force to infiltrate is a brigade.

Mobility

Infiltration is not limited to movements on foot. In some situations, the infiltrating force may include light vehicles and some armored vehicles. When possible, the inclusion of transportation can enhance combat power by providing additional fire support, long-range communications, and increased ammunition support. Army aviation can provide target acquisition fire support,

and fire direction. Army aviation also may be used in logistics support missions to permit a greater range of operations for the infiltrating forces and to evacuate casualties.

CONTROL MEASURES

The primary means for controlling an infiltration (while maintaining the flexibility to react to unforeseen situations) are tactical control measures and SOPs. Control measures for an infiltrating force must be simple. A discussion of infiltration control measures follows. (Also see Figure 7-16.)

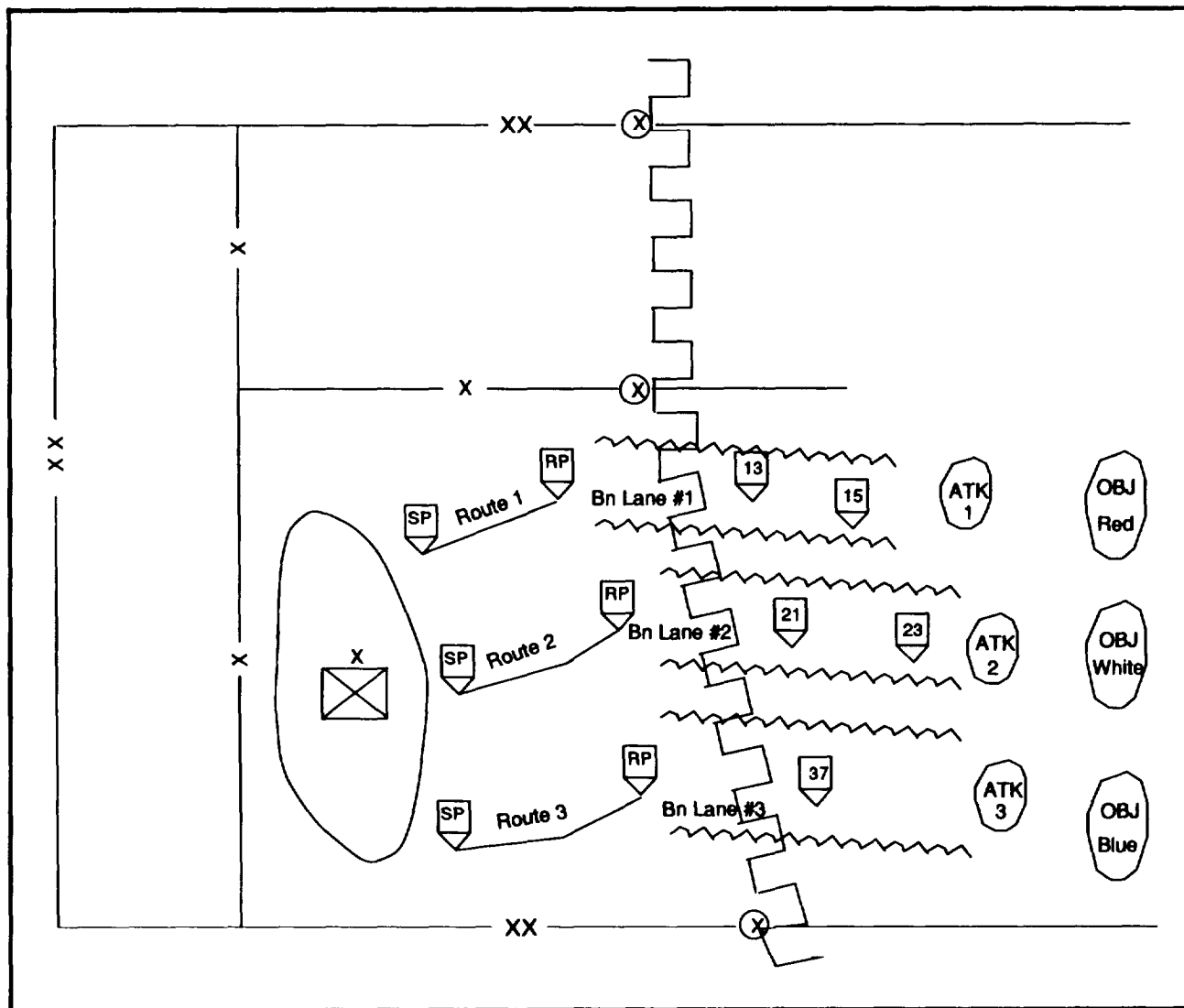

Figure 7-16. Infiltration: control measures

The rear assembly area is located in a hidden or concealed position to the rear of the FEBA. It must be close to the lanes to be used for the forward passage of lines through friendly forces.

Forward passage lanes must be as close to the rear assembly areas as the tactical situation permits. The distance between the assembly areas and passage lane will impact on the available time the infiltrating unit has to coordinate with the stationary unit and conduct reconnaissance of the passage and infiltration lanes, and on unit movement time.

An *attack position* or positions should be as close as possible to the objective without compromising security. An attack position must be large enough for the force to deploy and provide a covered and concealed position for infiltrating units to converge. It should be reconnoitered and secured before occupation. The position also can be used to make final adjustments prior to the attack. Link-up points are designated short of the attack position to facilitate its security and movement of elements from the infiltration lanes.

Hide positions are designated along the infiltration lanes for operations longer than one day. Infiltrating forces use these hide positions during the daylight hours to remain hidden from the enemy. Hide positions must provide covered and concealed locations which hide and disperse the force until movement resumes.

Checkpoints are probably the most critical control measure for an infiltration operation. They provide quick and easy reference to a present or future location.

Infiltration lanes or routes to the attack position are used to transition from forward passage of lines to movement to the attack position. They must be reconnoitered prior to movement by infiltrating forces. They contain a start point, RP, TRPs, rest (or hide) areas, and checkpoints. They are selected to avoid the enemy, provide cover and concealment, and avoid predictable routes which lend themselves to enemy ambush. The number of lanes required depends on the size of the infiltrating force, the time required, the availability of covered and concealed routes, and the nature of terrain.

Rally points are designated along each infiltration route by the infiltrating unit. They allow the dispersed infiltrating forces to rapidly regroup in response to unforeseen enemy contact and continue movement to the attack position. They should be easily identifiable and provide cover and concealment.

Axis of attack provides a general orientation to the objective for forces attacking from the attack position.

The *objective* is the main focus of the infiltration operation. It may be a fixed site on the ground or a moving unit.

Boundaries may be established by higher headquarters. They give the infiltrating units a specified AO for which they are responsible within the parameters of the operation.

Restrictive fire areas restrict friendly fires in enemy territory occupied by infiltrating forces. They are primarily established for attack positions, rest positions along infiltration routes, and at critical mission support locations.

SYNCHRONIZATION OF BOS

Coordination, integration, and synchronization of the BOS for an infiltration operation is much the same as for any other type of offensive or defensive operation. Infiltrating forces normally move through defending friendly units. Detailed coordination is required to execute a passage of lines through a defending unit. Careful consideration must be given to measures to deconflict and control fire support and movement through the defending units' counter-reconnaissance forces. Rarely will an entire division infiltrate. This would require infiltration over an extremely wide front. If the enemy is disposed in such a manner as to allow a division-sized infiltration, it is unlikely that an infiltration would be required at all. A deliberate attack or, if required, an air assault into the enemy's rear may be more appropriate.

Command and control of infiltrating forces is a difficult challenge. Simplicity is the ingredient for success. Infiltration operations are centrally planned and decentrally executed. Procedures for effective command and control must be established early—not only in the OPORD, but in the division's TSOP.

The division CP best suited to monitor and control infiltrating units is the TAC CP. Infiltrating units are committed to close operations and are under the control of the TAC. The TAC CP will normally locate well forward to monitor and support tactical requirements of infiltrating forces. The brigade executing the infiltration, or controlling subordinate infiltrating units, report to the TAC. The division main CP continues coordination and synchronization of future operations. It also provides required support for infiltrating forces.

Intelligence

Intelligence operations to support an infiltration require extensive, early efforts to locate and assess enemy capabilities along infiltration lanes and on objectives, and his potential reaction once the infiltration terminates and the attack begins. This initial IPB is critical; it establishes the ground work for the tactical concept of operations.

Information from intelligence reports, reconnaissance and patrol reports, weather and light data, and aerial photographs is used to determine infiltration lanes, locations of rally and contact points, enemy security elements, gaps in the enemy's defense, and strength of enemy defenses on the objective.

During the infiltration, divisional intelligence assets (and those of in-place units and higher headquarters) develop and maintain as accurate a picture as possible of the enemy and his activities. This effort must determine if the enemy has discovered the infiltration operation and, if so, what his reaction will be.

Electronic warfare assets are used to disrupt the enemy's C² system and prevent him from effectively countering the infiltration. Their use must be coordinated with defending friendly units to preclude disruption of their C². All intelligence information to and from infiltrating units is through the G2 cell at the TAC CP.

Fire Support

Fire support must be available to infiltrating forces throughout the operation. Brigade-sized infiltrations will normally have at least one DS FA battalion. DS artillery must be well-forward to

support both the infiltration and attack on the objective. Additional FA units should be placed in a reinforcing role to DS units during the infiltration, especially the longer-range 155-millimeter self-propelled howitzers of the corps artillery FA brigades.

The division should use MLRS only to support the attack and defend against any counterattacking forces during the infiltration or during reorganization on the objective.

Counterfire radar is positioned to support the infiltrating force. Fire support can support deception efforts by firing false preparations and programs into other areas of the battlefield. Close air support assets are allocated for the infiltrating force but used only in the attack or on early detection.

Air Defense

During the initial phases of the infiltration, corps and defending units provide AD for the infiltration. Since small infiltrating units normally do not present lucrative air attack targets, the threat of attack from the air is minimized. Depending on the threat, MANPAD assets may be needed with the infiltrating force. Other divisional AD assets are left behind but must be prepared to move forward to link up with infiltrating forces on the objective, as the situation permits.

Mobility and Survivability

Infiltrating forces will have limited mobility, countermobility, and survivability assets. These are normally limited to light engineers task-organized in infiltrating units. They can conduct limited breaching of enemy obstacles during the attack on the objective. Bangalore torpedo sections, limited demolitions, and a limited number of antitank mines are all they can realistically carry on the infiltration. The factors of METT-T are the primary decision source in this instance. The primary concern when task organizing maneuver elements with engineers is the engineer requirements during the attack on the enemy position. Considerations will normally focus on the covert or assault breaching requirements for the force, and then on any hasty defensive preparations required once the objective is secured.

Combat Service Support

Combat service support assets do not accompany infiltrating units but must be prepared to follow attacking forces which link up with the infiltrating force to support consolidation, reorganization, resupply, and medical evacuation. Depending on the tactical situation, it may be

possible to provide limited aerial resupply and medical evacuation to the force during the infiltration. However, since medical evacuation will be difficult and could compromise the infiltration, combat lifesavers and unit medics are critical. Infiltrating units must develop a detailed health service support plan which ensures a combat lifesaver or medic is with each infiltrating unit.

Section VII. AIR ASSAULT OPERATIONS

FM 90-4 is the Army's basic doctrine for air assault operations. Air assault operations are those in which assault forces (combat, CS, and CSS) maneuver on the battlefield via helicopter under the control of the ground or air maneuver commander to engage and destroy enemy forces or seize or hold key terrain. Air assault operations are deliberate, precisely planned, and vigorously executed. During air assault operations, the supporting aviation elements are task-organized with other members of the combined arms team to engage enemy forces.

The infantry division may routinely integrate army aviation and infantry units with other members of the combined arms team to conduct air assault operations. Air assaults enable the division to form powerful and flexible task forces to project combat power throughout the depth and width of the division's AOs without regard to terrain barriers. The commander must determine if the payoff for conducting the air assault is worth the pain the division may suffer as a result.

Prior to deciding to conduct an air assault operation, the division commander must carefully consider many factors. As a minimum, he must consider time, assets, and impact.

Is there sufficient *time* remaining to properly plan, coordinate, and synchronize such a complex operation? An air assault operation cannot be hastily conceived and coordinated.

Are there sufficient *assets* available, either from internal and external assets, to properly conduct the air assault? Piecemealing of forces into an air assault operation is dangerous.

What is the *impact* of air assault operations on the division's capability after the air assault has been completed? Normally, aircraft assets

will have to be borrowed from other missions to properly conduct the air assault. The impact of an air assault operation on crew rest, helicopter maintenance, and logistics resupply can be detrimental to the overall division battle.

Air assault operations are different in concept and executions from airmobile operations. Airmobile operations are those operations involving the use of Army airlift assets for other than air assaults. Airmobile operations are conducted to move troops and equipment, or transport ammunition, fuel, and supplies. During airmobile operations, aviation units are released to return to their parent units when an airlift is completed.

COMMAND AND CONTROL

Command and control in an air assault is basically the same as for other types of tactical operations. The air assault is planned and coordinated in the main CP. Rarely will the division conduct an air assault to support a deep operation. Distance, linkup, and logistics support make deep operations impractical for air assault operations. The TAC CP controls the air assault when it supports close operations; rear CP controls the assault in support of rear operations.

Air assault operations differ from other tactical operations in the designation of key personnel and their planning and command responsibilities. The following paragraphs describe key terms and vocabulary relating to air assault operations.

An *air assault task force* (AATF) accomplishes air assault operations. The AATF is a group of integrated forces tailored to a specific mission and under the command of a single headquarters.

The air assault *task force commander* (AATFC) designated by the ground or air maneuver commander, commands the AATF. The

AATFC may combine infantry brigades, battalions, or companies with aviation assets singly or in multiples.

The *air mission commander* (AMC) commands and controls all aviation elements and advises the AATFC on aviation-related matters on a specified mission or operation. The AMC is subordinate to the AATFC. He serves as a technical advisor throughout the conduct of air assault missions.

The *ground tactical commander* (GTC) commands and controls the assaulting elements prior to pickup at the PZ and after insertion into the LZ. If the GTC is not the AATFC, he is subordinate to the AATFC.

When the division conducts an air assault operation with one or more units (brigades, battalions, or companies) under division control, the division commander is designated as the AATFC. The aviation brigade commander serves as the AMC and the infantry brigade, battalion, or company commander serves as the GTC. In a company-level air assault, the battalion commander serves as the AATFC while the AMC will be the assault aviation company commander, and the rifle company commander will serve as the GTC.

OPERATIONAL PLANNING

An air assault task force is normally a highly tailored force designed to hit fast and hard. It is best employed in situations that provide a calculated advantage due to surprise, terrain, threat, or mobility. Some basic air assault planning guidelines are—

- Assign missions that take advantage of the air assault task force's mobility.
- Do not employ in force roles requiring deliberate operations over an extended period of time.
- Always task organize the air assault force as a combined arms team.
- Allow extra time for planning and preparing for night and adverse weather air assaults.
- Maintain unit integrity throughout air assault planning to ensure fighting unit integrity on landing.

- Plan and posture fire support to provide suppressive fires along flight routes and on LZs, and to suppress enemy air defense systems.

Planning Steps

Five separate but integrated plans are required to conduct an air assault operation. The ground tactical plan is the first and dictates the content of all others. These plans are developed *in reverse order of execution*, (Figure 7-17, page 7-30.) The normal sequence of air assault planning is—

1. Develop ground tactical plan (GTC).
2. Develop landing plan (AMC).
3. Develop air movement plan (AMC).
4. Develop aircraft loading plan (GTC).
5. Develop staging plan (GTC).

Ground Tactical Plan

The foundation of a successful air assault operation is the commander's ground tactical plan around which subsequent planning is based. The AATF staff prepares the ground tactical plan (with input from all task force elements). All aircrews must be familiar with the ground tactical plan and the ground commander's intent.

The ground tactical plan for an air assault operation comprises essentially the same elements as any other infantry attack but differs in the requirements for speed and mobility. Assault units are placed on or near the objective and organized so as to be capable of immediate seizure of objectives and rapid consolidation. If adequate combat power cannot be introduced quickly into the objective area, then the air assault force must land away from the objective and build up combat power. The air assault force then assaults like any other infantry unit and the effectiveness of the air assault operation is diminished. The scheme of maneuver may assume a variety of possibilities depending on the situation and METT-T.

Following are considerations for the ground tactical plan supported by an air assault operation. General considerations include—

- Choose appropriate assault objectives.
- Designate LZs available for use. Consider distance from LZs to the objectives.

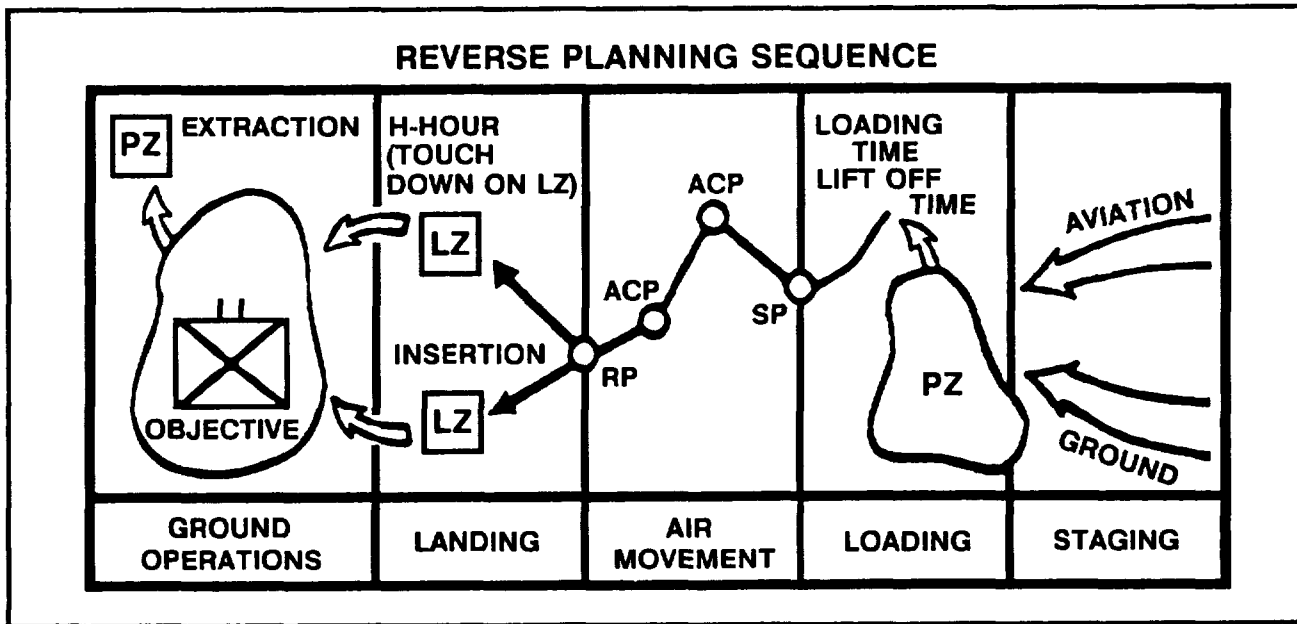

Figure 7-17. Air assault operations: planning sequence

- Establish D-Day and H-Hour (time of assault).
- Identify special tasks required to accomplish mission.
- Identify means to accomplish the mission: organic troops, aviation resources, engineers, signal, MEDEVAC.

Fire support considerations include—

- Close TACAIR support.
- Field artillery within range (rocket, missile, cannon).
- Other indirect fire weapons (mortar, naval gunfire).
- Preparation fires for LZs (signals for lifting and shifting).
- Flight corridors.
- Air defense suppression (ground/air, air/air, ground/ground).
- Control measures needed.
- Subsequent operations (defense, link-up, withdrawal) that may be conducted.

Intelligence considerations include—

- Enemy locations to include air defense positions and type.

- Ground and aerial reconnaissance of objective area (if practical).
- Sensor reports, terrain study, weather forecast.
- Intelligence summary.

Landing Plan

The landing plan must be synchronized with and support the ground tactical plan. The landing plan sequences elements into the AO, ensuring that units arrive at designated locations and times prepared to execute the ground tactical plan. There are three primary elements of the landing plan. The landing plan—

- Involves the selection of LZs by the AATFC and his staff with input from the AMC or his liaison officer.
- Considers landing formations to be used by the aircraft on the LZ to facilitate off-loading and deploying for the assault.
- Addresses fires required to support the landing.

It may be preferable to make the initial assault without preparatory fires in order to achieve tactical surprise. However, fires are always planned for each LZ so that they can be fired if needed. Planned fires for air assault operations are intense and short but with a high volume of

fire to maximize surprise and shock effect. All fires should end just before the first assault element's landing.

The following are considerations for the air assault landing plan:

• Selection of primary and alternate LZs with regard to proximity to cover and concealment, obstacles, identification from the air, exits from the LZ, capacity of LZ, enemy disposition and capabilities, and LZ security plan.

- Selection of single or multiple LZs as appropriate for the ground tactical plan.
- Landing formations.
- Approach and departure directions.
- LZ preparation fires to support landing plan and ground tactical plan.
- Use of aircraft after personnel have been landed.
- Use of pathfinders to mark LZ.

Air Movement Plan

The air movement plan specifies the schedule and provides instructions for air movement of troops, equipment, and supplies from PZs to LZs. The air movement plan is normally developed by the AMC or the aviation liaison officer. It coordinates instructions regarding air routes, ACPs and aircraft speeds, altitudes, and formations. The air movement plan requires consideration of the following factors:

- Development of flight routes.
- Designation of start point and release point.
- Air movement table.
- Flight corridor.
- Flight axis.
- Expedient flight routes.
- Flight route control measures.
- Terrain flight modes.
- Supporting fires along the flight route.
- Alternate communications.

Loading Plan

The loading plan is based on the air movement plan. It ensures that troops, equipment, and supplies are loaded on the correct aircraft and unit integrity is maintained when aircraft loads are planned. However, assault forces and equipment may be cross-loaded so that C² assets, all types of combat power, and a mix of weapons arrive at the LZ ready to fight. Aircraft loads are placed in priority to establish a bump plan. This ensures that essential troops and equipment are loaded ahead of less critical loads in case of aircraft breakdown or other problems.

Loading plans should be an integral part of the unit SOP below brigade level. The following are considerations for developing the loading plan:

- Cross-load requirements.
- Bump plan.
- PZ assignment by unit (primary and alternate), bump and or straggler contingency plan, and PZ control and security responsibilities.
- Holding areas.
- Routes from assembly areas to holding area to PZs.
- Refueling for multiple lifts.
- Attack helicopter utilization during PZ operations.

Staging Plan

The staging plan is based on the loading plan and prescribes the arrival time of ground units (troops, equipment, and supplies) at the PZ in the proper order for movement. Loads must be ready before aircraft arrive at the PZ; usually, ground units are expected to be in PZ posture 15 minutes before aircraft arrive.

The staging plan also restates the PZ organization, defines flight routes to the PZ, and provides instructions for linkup of all aviation elements. Air-to-air linkup of aviation units should normally be avoided, if possible.

Air Mission Brief

The air mission brief (AMB) is the final coordination meeting of key personnel involved in an air assault mission. The AMB is a working briefing covering all aspects of the mission. Any uncertainties must be addressed during the AMB as no changes are normally authorized subsequent to its completion without the consent of the AATFC. The AMB is a coordinated staff effort requiring input from all participants of the air assault operation. An AMB checklist, air movement table, and sketches of all primary PZs and LZs should be issued to the AATFC, GTC, and AMC. See FM 90-4 for details on the AMB.

Aircraft Specification

Throughout the concept development and planning for the air assault at the division level, the staff will require some types of generalized information concerning infantry units and air craft strengths, capabilities, and specifications. These planning specifications may change, depending

on the situation, but will help determine feasible courses within the capabilities of available resources. Aviation and infantry units are normally composed as shown in Figure 7-18. Figure 7-19 and Figure 7-20 provide additional aircraft specifications.

Aviation Units	
UH-60 Bn	30 (45) Aircraft
UH-60 Co	15 Aircraft
UH-1 Co	23 Aircraft
UH-60 carries 14 troops in seats, 21 without seats	
UH-1 carries 11 troops in seats, 15 without seats with optimum climatic conditions.	
Infantry Units	
Lt Inf Bn	543 Personnel
Lt Inf Co	124 Personnel

Figure 7-18. Air assault operations: composition of infantry and aviation units

AIRCRAFT		OH-58A	UH1H/V	UH60A	CH47C	CH47D	HH53H (USAF)
NAME	UNIT	KIOWA	IROQUOIS	BLACKHAWK	CHINOOK	CHINOOK	PAVELOW
NORMAL CREW (200 lb ea)	EA	2	2	3	4	4	8
LENGTH FUSELAGE	FT/IN	32' 3"	41' 11"	50' 7.5"	50' 9"	51'	65'
LENGTH OPERATING	FT/IN	40' 11.8"	57' 1"	53' 8"	99'	99'	78'
HEIGHT EXTREME	FT/IN	9' 7"	14' 8"	17' 1"	18' 12"	18' 8"	13' 4"
DIAMETER MAIN ROTOR	FT/IN	35' 4"	48'	53' 8"	60'	60'	46' 8"
DIAMETER TAIL ROTOR	FT/IN	5' 2"	8' 6"	11'	60'	60'	18'
MAX LIFT TAKEOFF	LBS	3,000	9,500	20,250	46,000	50,000	42,000
BASIC WEIGHT	LBS	1,586	5,132	10,500	20,481	22,499	28,150
MAX RECM XTNL LOAD	LBS	N/A	4,000	8,000	20,000	28,000	20,000
TROOPS/PARATROOPS	EA	2 / 0	11 / 8	11 / 8	33 / 28	33 / 28	36 / 20
LITTER/AMBULATORY	EA	2 / 2	3 / 4	4 / 6	24 / 33	24 / 33	8 / 30
MAX FLIGHT TIME	HR/ MIN	3 hrs	2:20	2:20	2:00	2:00	5:00 Refuel

Figure 7-19. Rotary wing aircraft specifications

AIR ASSAULT SYNCHRONIZATION PLANNING MATRIX (MISSION EXECUTION)

	F-1 to F-0:15	F-0:15 to F-HR	F-HR to F + 0:20	F + 0:20 to F + 0:40	F + 0:40 to F + 1
I N T E L	Receive timely data from CM&D, pass to 2-2 AHB Update enemy locations Final SPOTREP prior to crossing FLOT	QUICKFIX Jamming			
M V R	1-2 AHB provides security for AA 2-2 AHB arrives at PZ	1-2 AHB crossing FLOT 2-2 AHB crossing FLOT	1-2 AHB in overwatch position 2-2 AHB at LZ 1	1-2 AHB breaks contact and egress back to FLOT 2-2 AHB ceases AA OPs and egress back to FLOT	1-2 AHB at FAARP 2-2 AHB at FAARP 2-2 AHB ready for sling OPs
F S	Execution matrix initiated Final checks Activate A2C2 plan	Execute ingress SEAD FSCM go into effect AI into EA FAC controls CAS	Execute egress SEAD 2-2 AHB OH-58Ds call fire in support of AA		Execute egress SEAD
A D A					
C & C					
C S S					
D E C E P T I O N	1-2 AHB(-) conducts attack				
D E C I P S I O N I N T S	Is there a clear picture of the enemy locations? Did the OH-58D go FWD? (SPOT Report) Weather abort?	OH-58D confirm target location? Use OH-58D for security?	Commit more OH-58D to security?	Did AA meet Cdr's intent/CCIR? Reinforce AA? Do OH-58Ds need to remain on station?	
B D E	Coordinate FLOT crossing and AA O/O attack begins			Aircraft lost/missing?	
K E A Y C T	Request additional FS? Coord ARTY w/CAS				Prepare for another AA/ATK

Figure 7-20. Example assault operations: planning matrix

Section VIII. AIRBORNE OPERATIONS

The airborne division is unique in its capability to strategically deploy and conduct forced entry operations. The planning, preparation, and execution of airborne division operations involves four phases, FM 90-26 is the capstone manual for airborne operations and covers these in detail. These phases are—

- Ground tactical plan.
- Landing plan.
- Air movement plan.
- Marshaling plan.

GROUND TACTICAL PLAN

The ground tactical plan is the base from which all other plans are developed. The ground tactical plan must be completed before finalizing the landing plan, air movement plan, and marshaling plan. It provides the commander's intent, concept of the operation, fire support plan, and task organization for the initial assault. Ground combat in airborne operations is conducted along conventional lines but initially with limited assets and a heavy reliance on air support.

Planning

Once the airborne force commander receives the initiating directive or warning order, he begins planning. This directive *or* warning order includes the following:

- Missions for subordinate units.
 - Higher commander's concept of the operation.
 - Command structure for the operation.
 - Time and duration of the operation.
 - Intelligence and security requirements.
 - Allocation and distribution of airlift assets.
 - Unit deployment list and sequence.
 - Departure airfields, remote marshaling bases (REMABs), and ISBs.
 - Signal requirements and instructions.
- Ž Link-up and withdrawal concept.

Estimate of the Situation

The military decision-making process incorporating the estimate of the situation results in a

course of action as in any other operation. Unit commanders and staff officers cannot afford to deviate from this accepted procedure for the development process. As a technique, the ground tactical plan will normally be developed as the basic OPORD or OPLAN. This is the most critical phase of an airborne operation because all other plans are based on it.

Mission. The mission of the airborne division is to close with the enemy by fire and maneuver to destroy or capture him, or to repel his assault by fire, close combat, and counterattack. These missions usually require the seizure and defense of objectives and surrounding terrain. (See FM 90-26 for detailed information on the application of the IPB process as it relates to airborne operations.)

In early link-up operations, the unit defends only the airhead and the required maneuver space. In link-up and independent operations, tactical operations begin with an initial assault and then pass to the defense of the established airhead unit until enough forces can be delivered to the objective area. On reinforcement or on linkup with other ground forces, the division resumes the offensive within the commander's concept of the operation or prepares for subsequent operations.

Enemy Forces. The commander and division staff analyze available information to determine the enemy situation. The following are considered:

- Enemy morale, leadership, and probable intentions.
 - Enemy capabilities.
- Ž Enemy tactics.
- Probable enemy reactions to an airborne assault.
 - Enemy reserves and paramilitary organizations (gendarmeries, police, border guards, and militia) and their ability to mobilize and react.
 - Enemy capability to conduct guerrilla, partisan, or sabotage activities and the enemy's relationship to the local population.

Terrain and Weather. Within this category, the staff must consider the following factors:

- Availability of DZs, LZs, and extraction zones (EZs). The availability and selection of DZs should not influence the selection of assault objectives, the airhead line, or unit boundaries.

Ž Obstacles within the airhead line and out to the maximum effective range of direct- and indirect-fire weapons, with emphasis on those that can be prepared or reinforced with minimal engineer effort.

Ž Enemy avenues of approach, This consideration weighs heavily in determining the location of assault objectives.

- Key terrain that can assist the force in best defending the area in depth.
- Friendly and enemy observation and fields of fire.
- Cover and concealment for assembly and reorganization.

The staff must also consider the effects of climate and weather on—

- Flight formations.
- Trafficability.

Ž Visibility.

Ž Close air support.

- Logistics.
- Personnel and equipment.

Troops Available. The division commander considers all forces available to accomplish the mission. These include assigned, attached, and supporting forces.

The commander considers the plans, missions, capabilities, and limitations of *US ground forces*. He must consider whether artillery can support the division and whether the forces will perform a linkup or passage of lines.

The commander must consider *USAF* ability to support the division and must bring knowledgeable airlift and tactical air planners together early. Close air support can often make up for the lack of armor and heavy artillery.

The commander examines availability and feasibility of naval gun fire (NGF) support and Navy or *USMC* air support. He must arrange early for liaison and coordination to support the operation.

Time. There are several time considerations unique to an airborne operation. Significant time may be required to mass AF aircraft. The time between the initial assault and deployment of follow-on forces must be considered. Supply and CSS planning are driven by the amount of time before linkup or withdrawal.

Indigenous Population. The commander must consider national and regional characteristics, such as—

- Religion and customs.
- Politics and tribal affiliations.
- Support (or lack of it) for central and local governments or occupying powers.
- Loyalty to political or military leaders.
- Available labor.

Ž Support (or lack of it) for US forces.

Development of the Ground Tactical Plan

The ground tactical plan incorporates considerations for those actions to be taken in the objective area. It must focus on accomplishing the commander's concept of the operation. It is developed as any other tactical plan; however, the initial goal of the airborne operation is establishment and defense of an airhead.

The ground tactical plan's essential elements are developed in the following sequence: airhead line and assault objectives, security zone and R&S forces, boundaries and assault task organizations, and reserves.

Selection of Assault Objectives and the Airhead Line

Based on an analysis of the situation, the commander selects specific assault objectives. (Figure 7-21, page 7-36.) Although the airhead line is developed and the assault objectives determined concurrently, assault objectives dictate size and shape of the airhead.

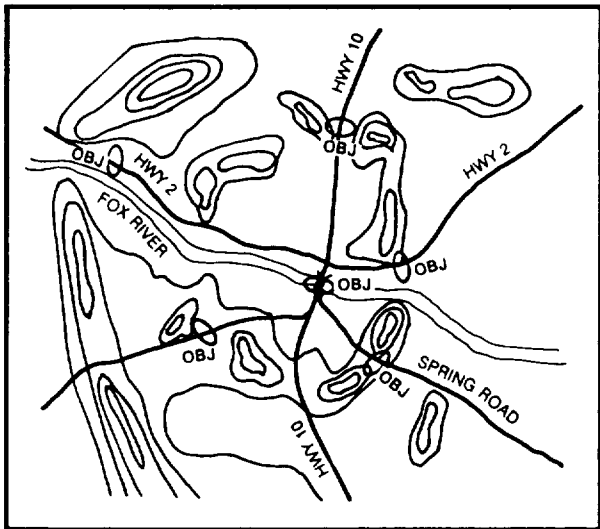

Figure 7-21. Assault objectives

This selection does not necessarily include objectives the force must seize to secure the airhead line. An appropriate assault objective is one which the force must control early in the assault to accomplish the mission or enhance security of the division.

Objectives should allow for accomplishing mission-essential tasks while meeting the commander's intent. They can include key terrain within the airhead or terrain required for linkup. The division is vulnerable from the time it lands until follow-on forces can be delivered to the airhead. A mobile enemy unit attacking the airhead immediately following the airborne assault can completely disrupt the operation. Therefore, the commander selects assault objective terrain that dominates high-speed enemy avenues of approach into the airhead. Enemy positions which threaten the mission and are within the airhead can also be selected as assault objectives. Assault objectives must be seized immediately to establish the airhead and provide security for follow-on forces.

Subordinate commanders decide the size, type, or disposition of the force to gain and maintain control. Division selects brigade assault objectives, while the brigade selects battalion assault objectives. Battalion selects company assault objectives.

Assault objectives are ranked in order. Priorities are chosen based on the most likely threat or

mission requirements. Assault objectives are secured before the airhead line defense is established. The airhead is then cleared of organized enemy resistance and forces are positioned to secure the airhead line.

At the same time commanders select assault objectives, they consider the extent of the airhead. The airhead includes the entire area under control of the airborne force. It acts as a base for further operations and as the lodgment that allows the airborne force to buildup combat power. Once the force secures the airhead, it must clear enemy forces within it to defend it.

The airhead line delineates the specific area to be seized and designates the airhead. Several factors determine the location, extent, and form of the airhead line:

- The actual trace of the airhead line reflects the control of key or critical terrain essential to the mission. (Figure 7-22.)

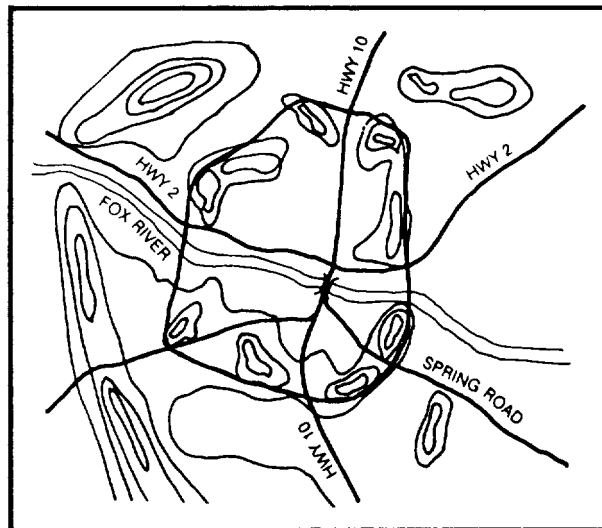

Figure 7-22. Airhead line

- The airhead line anchors on obstacles, and the airhead itself takes advantage of existing natural and man-made obstacles.

- The airhead contains enough DZs, LZs, and EZs to ensure interior rather than exterior lines of communication and to permit mass rather than piecemeal assault.

- The airhead must allow enough space for dispersion to reduce vulnerability to NBC weapons.

- The airhead must be large enough to provide for defense in depth, yet small enough for the unit to defend. Although this depends largely on METT-T, a battalion can defend an airhead 3 to 5 kilometers in diameter. A brigade can occupy an airhead 5 to 8 kilometers in diameter.

Reconnaissance and Security Forces

Security in all directions is an overriding consideration in any airborne operation since the airhead is a perimeter defense. In ground operations, there are several security echelons forward of the FEBA.

Security forces are landed in the assault echelon. A reconnaissance and security line is established immediately 4 to 6 kilometers from the airhead line to provide security to the airborne force. In the early stages of an airborne operation, the security force acts as a screening force. In later stages when assault missions have been accomplished and the airhead is relatively secure, it acts as a guard or covering force. The mission of the security force is to—

- Give the airhead early warning.
- Develop intelligence, including the location, direction, and speed of an enemy attack.
- Initially deny the enemy observation of, and his fires on, the airfield.
- Deceive the enemy as to the actual location of the airhead.
- Delay and disrupt the enemy.

The security force includes scouts, AT weapons, engineers, Army aviation, and (sometimes) light armor. When possible, mobile forces are selected to facilitate rapid initial movement to positions and to facilitate withdrawal and adjustment. An aggressive R&S effort at lower echelons augments the security force. The following considerations apply to the selection of positions for the screening force:

- Locate within radio communications and FS range. Range can be extended, if necessary, with retransmission stations; split section indirect-fire operations; and attachment of vehicles, mortars, or other assets.

- Locate as roadblocks, obstacles, ambushes, patrols, or sensors on dominant terrain. This allows long-range observation and fields of fire out to the maximum range of support fires.

- Locate to observe, control, and dominate high-speed avenues of approach into the airhead.
- Locate to deny enemy long-range observation and observed indirect fire into the airhead.
- Locate with routes of withdrawal to the airhead.

Designated forces under control of the airborne commander perform R&S missions beyond the security zone. Emphasis is on likely enemy avenues of approach. The mission of these forces is to gain and maintain contact with enemy units reacting to the airborne assault. This force is mobile and not used to defend a particular part of the airhead. It can include Army aviation, air cavalry, or light armor; it can be supported with fire from AF assets, NGF, or Army missile systems. These forces orient on enemy high-speed avenues of approach to develop intelligence, including the location, direction, and speed of any enemy advance.

Employed beyond the airhead at a distance based on the tactical situation, security forces protect the main force from surprise attack. The airborne commander can extend their range if communications permit. Aviation assets can extend to 50 kilometers or more, although the commander must consider loiter time so forces can provide continuous coverage. (FARPs can increase this distance.) Long-range surveillance teams may observe enemy garrisons and major routes into the airhead. Reconnaissance forces must be mobile and task-organized for the mission from cavalry, armor, scout, LRS, and antiarmor units.

Boundaries and Task Organization

The division commander visualizes employment of brigades and organizes them for combat commensurate with their assigned missions.

Boundaries. The commander uses boundaries to assign sectors of responsibility to major subordinate combat elements, who then clear AOs of enemy forces. (Figure 7-23, page 7-38.)

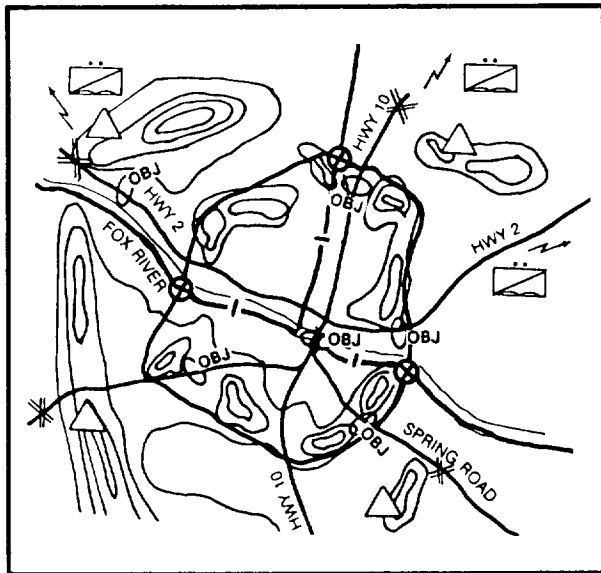

Figure 7-23. Boundaries: division airhead

To assign boundaries, commanders subdivide the area into sectors with fairly equal tasks (not necessarily into equal sectors). This requires a careful analysis of the enemy, tasks to be accomplished, and terrain within the objective area.

Boundaries should avoid splitting (between two units) the responsibility for the defense of an avenue of approach or key terrain. Boundaries should provide adequate maneuver space including key terrain features. Boundaries should provide adequate room to permit maneuver on both sides of the assault objectives.

Boundaries must be recognizable both on the map and ground. Roads should not be used as a boundary because they represent high-speed avenues of approach and need to be covered with a clear understanding of responsibility. Instead, commanders can use such landmarks as rivers, streams, railroad tracks, or the edge of a town, woods, or swamp.

Ideally, each sector should include at least one DZ and LZ to enable the unit and its attachments to land within the assigned sector during the assault. This also facilitates resupply and evacuation of EPWs and casualties. Having an LZ and DZ reduces the problem of coordination with adjacent units.

Boundaries should not require a unit to defend in more than one direction at once. Bound-

aries should extend beyond the trace of the security force as far as necessary to coordinate fires. This allows subordinate units to operate forward of the airhead with minimal coordination. Commanders should plan coordinating points at the intersection of the airhead line and security force ground trace boundaries.

Task Organization. Once the commander has determined the principal features of the ground assault plan (scheme of maneuver and fire support), he organizes units to execute their assigned missions. Units determine their boundaries at the same time. To ensure unity of effort or to increase readiness for combat, part of or all subordinate units of any command can be formed into one or more temporary tactical grouping (teams or task forces), each under a designated commander. No standard team organization meets all conditions.

Infantry units usually form the nucleus tactical grouping of the team; infantry unit commanders lead the teams. These teams are tailored for initial assault by the attachment of combat, CS, and CSS units. They are attached as soon as possible in the marshaling area. Many units detach as soon as centralized control can be regained, and the parent unit headquarters can establish itself on the ground. Other units such as higher echelon assault CPs are attached for the movement only. Attachments for airborne brigades usually include the following:

- A FA battalion.
- A combat engineer company.
- A MP platoon.
- A light armored company or platoon.
- An IEW support element, usually from the MI battalion.
- A forward area support team.
- An ADA battery.
- Other assets, as determined necessary by the division commander based on his estimate of the situation.

Organization for Assault Landing. After the task organization of soldiers for the assault landing is announced, units organize into assault, follow-on, and rear echelons.

The *assault echelon* comprises those forces required to seize the assault objectives and the initial airhead, plus their reserves and supporting soldiers.

The *follow-on echelon* is not needed by the airborne force in the objective area during the initial assault, but is needed for subsequent operations. When needed, the follow-on echelon enters the objective area as soon as practical by air, surface movement, or a combination of the two. It includes additional vehicles and equipment from assault echelon units, plus more combat, CS, and CSS units. The existence of any one of the following conditions requires an airborne unit to have a follow-on echelon:

- Shortage of aircraft.
- Ž Inability of aircraft to land heavy items of equipment.
- Any enemy situation, terrain, or weather that makes it impossible to land certain soldiers or equipment in the assault echelon.

The *rear echelon* includes the part of an airborne unit that is not considered essential for initial combat operations. It also includes people left at its rear base to perform administrative and service support functions which cannot be done efficiently in the combat area. The rear echelon is normally small for a brigade or battalion. Higher headquarters usually controls the rear echelon for all units. It can rejoin the unit when the brigade remains committed to sustained combat for a prolonged or indefinite period. Also, if the airborne force continues in the ground combat role after linkup, the rear echelon maybe brought forward.

Designation of Reserve

The employment of the reserve element follows the normal employment of a reserve unit in a ground operation.

Division Reserve. The division reserve can be held in the departure area ready to be committed by air when and where the situation dictates. A battalion can be the division reserve. This usually happens in large-scale airborne operations when suitable airfields in the airhead are not available; however, it can cause delays in commitment—

- Ž If signal communications fail.

Ž If the air move is very long.

Ž If flying weather is unfavorable.

- If time is added for coordination of air cover.

With the reserve element at the departure airfield, the reserve commander must continue planning for possible future commitment of his forces as far as maps, photos, and information of the situation permit.

Brigade and Battalion Reserves. These reserves enter the airhead as part of the assault echelon. They provide depth to the airhead by blocking penetrations, reinforcing committed units, and counterattacking the enemy. They consist of not more than a company at brigade level or a platoon at battalion level; however, their small size is dictated by tactical considerations and assigned missions. Commanders should organize, task, and position the reserve to ensure its size is compatible with likely missions, and that the reserve—

- Comes from the unit with the fewest priority tasks.

- Is not assigned assault objectives or a sector of the airhead to defend.

Ž Is near areas of likely employment, such as near the main enemy avenues of approach, to speed commitment.

- Is mobile. (This can be achieved using organic vehicles-antiarmor company, support platoon, light armor, and so on.)

- Is located in an assembly area (both initial and subsequent) or battle position, so that it does not interfere with units assigned assault objectives.

- Is near a LOC in a covered and concealed location to provide ease of movement, to reinforce, or to block.

- Is located within the sector of one unit, if possible.

The reserve's location allows for dispersion of the force. The reserve commander prepares and rehearses commitment contingencies according to guidance received from the commander designating the reserve.

Execution

Execution of the ground tactical plan involves the initial seizure of DZs and LZs in and around the airfield or the actual seizure of an airfield. (Chapter 3 discusses offensive operations.)

Conduct of the Assault

The initial assault emphasizes the coordinated action of small units to seize initial battalion objectives before the surprise advantage has worn off. As assault objectives are seized, the airborne force directs its efforts toward consolidating the airhead.

Tactical surprise and detailed planning should enable units to seize their assault objectives and to establish the airhead before the enemy has time to react in force. Missions of units are changed as required by the enemy's defense of initial objectives. The enemy can be expected to quickly launch uncoordinated attacks along major avenues of approach using local forces. The degree of coordination and strength of these attacks increase progressively; the airborne force must develop correspondingly greater strength in its defensive positions. Preparation of early defense against armored attack is a major consideration.

Units assigned to perform R&S missions land in early serials so that they can establish roadblocks, locate enemy forces, disrupt enemy communication facilities, and provide the commander with early warning, security, and information. Since ground reconnaissance by unit commanders is seldom possible before the airborne operation, it must begin as soon as the unit lands. The flow of information must be continuous. Information requirements do not vary from those employed by other ground units. However, the unit's method of arrival in the combat area makes immediate and thorough reconnaissance and transmission of information to higher headquarters necessary.

If the initial objectives are heavily defended, the bulk of the force has the task of seizing these objectives. When initial objectives are lightly defended, the bulk of the force can clear assigned sectors and prepare defensive positions in depth. Extensive patrolling is initiated early between adjacent defensive positions within the airhead line and between the airhead and the R&S line. Army aircraft are well suited for support of this

patrolling effort. Contact with any friendly guerrilla forces in the area is established as soon as possible.

Personnel are briefed on unit, adjacent and higher units, and alternate plans. This helps units or personnel landing in unplanned areas to direct their efforts to accomplishing the mission. Misdelayed units or personnel establish contact with their respective HQ as soon as practical.

Sufficient communications personnel and equipment must move into the airhead in advance of the CP to ensure the timely installation of vital communications. As soon as communications and the tactical situation permit, commanders regain centralized C². For effective C², immediate establishment of the following is necessary

- Command fire control channels within the airborne forces.
- Communications with supporting air and naval forces.
- Ž Communications with airlift forces concerned with buildup, air supply, and air evacuation.
- Communications with bases in friendly territory.
- Ž Communications between widely separated airborne or ground forces, such as link-up forces, with a common or coordinated mission.

The commander influences the action by shifting or allocating FS means. He may also-

- Ž Move forces.
- Ž Modify missions.
- Change objectives and boundaries.
- Ž Employ reserves.
- Move to a place from which he can best exercise personal influence, especially during the initial assault.

With initial objectives secured, subordinate units seize additional objectives to expedite establishing a coordinated brigade defense or the conduct of future operations. Defensive positions are organized, communications supplemented, and reserves reconstituted. These and other measures prepare the force to repel enemy counterattacks,

minimize the effects of nuclear weapons, or resume the offensive.

Reserves prepare and occupy blocking positions, pending commitment. Typical missions for reserves committed include taking over the missions of misdelivered units, dealing with unexpected opposition in seizing assault objectives, and securing the initial airhead.

Development of the Airhead

After the force makes the initial assault landings and accomplishes its initial ground missions, commanders must organize the airhead line.

Size. The airhead line extends far enough beyond the landing area to ensure uninterrupted landings of personnel, equipment, and supplies. It secures requisite terrain features and maneuver space for such future offensive or defensive operations as the mission calls for.

Occupation and Organization. Units occupy and organize the airhead line to the extent the situation demands. Commanders adjust the disposition of units and installations to fit the terrain and the situation. Units take R&S measures, which usually include reinforcing the R&S line. The degree to which the airhead line is actually occupied and organized for defense is largely determined by the mission, enemy capabilities, and defensive characteristics of the terrain.

Buildup. This proceeds concurrently with seizure and organization of the airhead line. As more combat personnel arrive and commanders organize them by unit, frontline positions are reinforced, reserves are constituted, and preparations are made for such offensive operations as the mission requires.

Buildup of Combat Power

The buildup of combat power is the introduction of the follow-on echelon into the airhead. This increase of combat power yields an ability to conduct defense of the airhead and short-term sustainment of forces. The intent of the buildup is to provide a secure operating logistics base for forces working to move the airhead away from the original point of attack. Usually, this distance is equal to the enemy's direct fire capability to harass and destroy incoming aircraft or landing craft (5 to 10 kilometers).

The composition of the follow-on echelon depends on the factors of METT-T. It can comprise a light or long-range field artillery, and combat engineers as well as significant CS and CSS elements. Other forces required can include—

- Infantry.
- Armored and light task forces.
- Armored units task-organized with light forces already in the objective area.
- Field artillery.
- Engineers in addition to those in the assault echelon.
- ADA.
- CSS assets.

The time involved in defensive operations, if any, varies. It depends on the mission assigned, composition and size of the force, enemy reaction, and type of operation contemplated. A well-prepared defense in short-duration missions in isolated objective areas may not be required. Security can be accomplished by completely, or almost completely, destroying or dispersing the enemy forces in the immediate objective area during the assault; then, airlifting the striking force before executing a coordinated enemy counter-attack.

Defense of an Airhead. The airborne force usually defends an airhead by securing key terrain with the airhead and dominating likely avenues of approach. Units deny the enemy areas between the occupied positions with a combination of patrols, mines, fire, and natural and man-made obstacles. Units aggressively reconnoiter between positions within the airhead, then forward of the airhead. The airhead configuration allows the commander to shift forces, reserves, and supporting fires quickly to reinforce another sector of the airhead. Regardless of the form of defense chosen, the force prepares positions in depth within its capabilities.

Defense During Withdrawal. Should withdrawal from the initial positions be required, the final area to which the airborne force withdraws must contain adequate space for maneuver, for protection of critical installations, and for planned air landing or air evacuation operations.

Defense Against Armor. During the initial phases of an airborne operation, one main defense against enemy armored forces is TACAIR support. Aircraft attack enemy armored targets as they appear, as far as possible from the objective area, and continue to attack and observe them as long as they threaten the airborne force. Strongpoints defending the airhead use natural obstacles, mine fields, tank traps, demolitions, and man-made obstacles. Units emplace antitank weapons in depth along avenues of approach favorable for armored forces. They cover all dangerous avenues of approach with planned fires. The Dragons and light antitank weapons (LAWS) of the rifle companies, TOWS of the battalion antiarmor company, AT weapons of division aviation units, and organic light armored forces give the airborne force a substantial amount of anti-tank firepower. Some of the antitank weapons, organic to battalions that are holding sectors not under armored attack, can be moved to reinforce threatened sectors.

Defense Against Guerrilla Action and Infiltration. The defense must include plans for countering enemy guerrilla attacks or infiltrated forces attacking the airhead area.

LANDING PLAN

The commander finalizes the landing plan after completing the ground tactical plan. The landing plan phases forces into the objective area at the correct time and place to execute the ground tactical plan. The execution of the landing plan is vital to the swift massing of combat power, protection of the force, and subsequent mission accomplishment.

Planning

The landing plan links air movement with the ground tactical plan. The landing plan is published at the brigade level and below, but is informal and not published at the joint level. The landing plan is a tabulation of the sequence, method, and destination of paratroopers and materiel into the objective area. The landing plan has five elements:

- Sequence of delivery.
- Method of delivery.
- Place of delivery.

- Time of delivery.
- The assembly plan.

Requirement

To develop the landing plan, commanders at each level need to know their commander's priorities, airlift tactics, landing area study, parent and subunit task organization and ground tactical plans, and subunit landing plan. During the backbrief of the ground tactical plan, the commander establishes airlift and delivery priorities and airlift tactics. He provides as much of this information as possible to subunits at the end of the ground tactical plan backbrief.

Commander's Priorities. The commander must set the priorities for each assault objective to determine the delivery sequence for units to secure these objectives. This does not necessarily match the sequence in which the units secure objectives. The commander must also know the—

Ž Priorities for deliveries on each DZ (personnel drop, CDS, heavy drops, and LAPES).

- DZ sequence.
- Priorities for delivering the remainder of the force.

Ž Method of delivery for units and equipment.

- Priorities for use of EZs.

Ž Location of the heavy equipment point of impact (HEPI) and the personnel point of impact (PPI).

Airlift Tactics. The AF element responsible for selecting airlift tactics develops them with the Army element to best support the ground tactical plan. These tactics include aircraft formations and sequence of personnel drops, heavy drops, and LAPES. The Army element chooses the sequence and time interval between serials, which are groups of like aircraft (C-130s, C-1415) with the same delivery method (personnel drops, heavy drops, LAPES) going to the same DZ.

Landing Area Study. The division staff, working with US Army topographic engineers and the Air Force, develops the landing area study and provides it to subunits. This study enables subunits to select the location, size, and orientation of DZs to best support their scheme of maneuver.

Subunit Landing Plans Subordinate commanders should develop landing plans to support their own respective schemes of maneuver. Subunits then backbrief their landing plans so higher headquarters can finalize the plan. Units must also know the initial locations of CS and CSS elements. This information should become available as subunits backbrief their ground tactical plan.

Considerations

Commanders should examine the following considerations when developing the landing plan.

Attacking an Objective. There are three basic methods of attacking an objective.

Jumping or landing on top of the objective works best for attacking a small objective that is specially fortified against ground attack. However, an airborne landing into an area strongly defended against air attack requires surprise to succeed.

Jumping or landing near the objective works best for the capture of a lightly defended objective which must be seized intact (such as a bridge). If the enemy has strong defenses against air attack, only surprise can enable the unit to achieve success with few casualties.

Jumping or landing at a distance from the objective is the least often used of the techniques available. Airborne forces use this method for large complex objectives that must be seized by deliberate attack. The DZ is selected to emphasize security and preservation of the force. The plan is based on METT-T considerations and should capitalize on the principle of surprise.

Landing Methods. There are two basic landing methods—multiple and single drop zones. With *multiple drop zones*, there are a number of small airheads in the objective area. This technique supports the principle of mass by placing the maximum number of paratroopers in the objective area in the minimum amount of time. Additionally, the commander can capitalize on the principle of surprise because the main effort is not easily determined by the enemy. This technique is normally used by division-sized elements and larger.

Brigade and smaller-sized airborne forces often establish an airhead by conducting the air-

borne assault onto a *single drop zone*. This technique allows the assaulting unit to assemble quickly and mass combat power against the enemy.

Time-Space Factors. Commanders schedule the delivery sequence and the time between serials to provide the least time and distance separation between each aircraft and serial. The airborne force assembles maximum combat power on the DZ as quickly as possible, using either of the following options:

- Land all elements in the same area. Aircraft approach the DZ in a deep, narrow formation and all soldiers jump into a small area.
- Land all elements at the same time. Aircraft in a wide formation approach various DZs situated close to each other and all soldiers jump at the same time or as near to it as possible.

Landing Priorities Airborne units are cross-loaded to land close to their assault objectives.

Organization. Airborne forces try to maintain tactical unity. Battalions or battalion TFs normally land intact on a single DZ. A brigade lands in mutually supporting DZs. Two or more battalions land successively on the same DZ or each can land on a separate DZ within a general brigade DZ area.

The airborne force sends as many assault unit personnel and equipment as possible into the area in parachute serials. Commanders must consider the mobility of equipment after the landing. For example, carriers or prime movers deliverable by parachute but difficult to handle on the ground can accompany the weapons in the assault element. Paratroopers accompany their units' principal items of equipment.

Sequence of Delivery

The commander's priorities within the ground tactical plan determine the sequence of delivery. Neither aircraft allocations nor availability of aircraft should influence these decisions. The commander determines final aircraft allocations after the landing plan backbriefs. Aircraft serials may precede the main airlift column to drop AF combat control teams (CCTs) and Army R&S units. The CCT places and operates navigation aids on the drop and landing zones; the R&S units

provide surveillance on NAI and report to the ground force commander.

Method of Delivery

This part of the landing plan addresses how the force arrives in the objective area with its needed supplies and equipment. The assault echelon comes in by parachute. The commander can use a number of other means to introduce additional personnel, equipment, and supplies into the objective area.

Personnel Airdrop. The airborne force delivers assault personnel by parachute drop. This method allows quick, nearly simultaneous delivery of the force. Planners choose any terrain free of obstacles that allows the assault force to land on or close to objectives. In some cases and with special equipment, it can deliver personnel into rough terrain. Special teams can use high altitude, high opening (HAHO) or high altitude, low opening (HALO) techniques. These techniques allow for early delivery of the joint airborne advance party (JAAP) without compromising the objective's location.

Equipment and Supply Airdrop. Airborne forces can airdrop supplies and equipment directly to units behind enemy lines or in other unreachable areas. The advantages of this are—

• Prerigging and storing emergency items for contingencies considerably reduces shipping and handling time and increases responsiveness.

• Since the delivery aircraft does not land, there is no need for forward airfields or LZs or materiel handling equipment for offloading.

• This reduces flight time and exposure to hostile fire and increases aircraft survivability and availability.

• Ground forces can disperse more since they are not tied to an airfield or strip.

The disadvantages of airdropping supplies and equipment are—

• Airdrops require specially trained rigger personnel and appropriate aircraft.

• Bad weather or high winds can delay the airdrop or scatter the dropped cargo.

• Ground fire threatens vulnerable aircraft making their final approach, especially if mountains or high hills canalize the aircraft.

• Since the aircraft do not land, no opportunity for ground refueling exists. Planned aerial refueling can extend aircraft range and should be considered on long flight legs to increase objective area loiter time and mission flexibility.

• Bulky airdrop rigs for equipment prevent the aircraft from carrying as much cargo as when configured for air landing.

• The possibility of loss or damage to equipment during the airdrop always exists.

• Ground forces must secure the DZ to prevent items from falling into enemy hands.

• Recovery of airdropped equipment is slow and manpower intensive.

Air-land Operation. Airborne forces can accomplish certain phases of airborne operations, or even the entire operation, by using air-land operations to deliver personnel and equipment to the objective area. (See FMs 7-20, 7-30, and 100-27.)

In some cases, air landing rather than airdropping personnel and equipment may be advantageous. Air landing—

• Provides the most economical means of airlift.

• Delivers Army aviation elements, engineering equipment, artillery pieces, and other mission-essential items in one operation.

• Provides a readily available means of casualty evacuation.

• Allows units to maintain tactical integrity and to deploy rapidly after landing.

• Allows the use of units with little special training and equipment.

• Does not require extensive preparation and rigging of equipment.

• Offers a relatively reliable means of personnel and equipment delivery regardless of weather.

• Precludes equipment damage and personnel injuries units may experience in parachute operations.

- The disadvantages are that air landing—
- Ž Cannot be used for forced entry.
 - Ž Requires moderately level, unobstructed LZs with adequate soil trafficability.
 - Ž Requires more time for delivery of a given size force than airdrop, especially for small, restricted LZs.
 - Generally requires improvement or new construction of air-land facilities, which adds to the engineer workload.
 - Ž Requires some form of airlift control element support at offloading airfields. Mission intervals depend on airlift control element size, offloaded equipment availability, and airfield support capability.

The tactical integrity of participating units is a major consideration in an air-land operation. Small units that are expected to engage in combat on landing, air land organizationally intact with weapons, ammunition, and personnel in the same aircraft whenever possible. Joint planning stresses placing units as close as possible to objectives, consistent with the availability of LZs and the operational capability of the tactical aircraft employed. Because of aircraft vulnerability on the ground, units unload as quickly as possible.

The airborne commander determines the makeup of each aircraft load and the sequence of delivery. The mission, the tactical situation, and the assigned forces influence this decision.

Units should use existing facilities, such as roads and open areas, to reduce the time and effort required for new construction. They should consider layouts that facilitate future expansion and provide maximum deployment and flexibility. As the size and efficiency of an air facility improves, its value to the enemy as a target increases. To reduce this vulnerability, the facilities should be dispersed and simple.

Place of Delivery

The selection of DZs, LZs, and EZs is a joint responsibility. The airlift commander is responsible for the precise delivery of personnel and cargo to the DZ or LZ and for the selection of approaches to the DZ. Both the joint and component commanders must base their decisions on knowledge of their respective problems and on the

needs of the overall operation. The nature and location of landing areas is important when preparing the scheme of maneuver. The mission governs the general area in which they are to be established. At higher echelons, commanders can assign landing areas in broad general terms. In lower units, leaders must describe their locations more specifically. Drop zones are selected only after a detailed analysis. Commanders should consider the following factors when making their selections.

Ease of Identification. The DZ should be easy to spot from the air. Airlift pilots and navigators prefer to rely on visual recognition of terrain features to accurately deliver personnel and equipment.

Straight-line Approach. To ensure an accurate airdrop, the aircraft should make a straight-line approach to each DZ for at least 10 miles, or about four minutes at drop airspeed, before the start of the drop.

Out of Range. The commander should choose a DZ that allows the units to avoid enemy air defenses and strong ground defenses, and puts them outside the range of enemy suppressive fires. To get to the DZ, aircraft should not have to fly over or near enemy anti-aircraft installations, which can detect aircraft at drop altitudes. They should fly over hostile territory or positions for the least possible time.

Close To or On Top of Assault Objectives. If the enemy situation permits, the commander should choose a DZ directly on top of assault objectives.

Suitable Weather and Terrain. The commander must consider seasonal weather and terrain when selecting DZs because these conditions affect their use. Adverse weather effects can be devastating. Ground fog, mist, haze, smoke, and low-hanging cloud conditions can interfere with the aircrew's observation of DZ visual signals and markings. However, they do offer excellent cover for blind or area DZs. Excessive winds also hamper operations.

Flat or rolling terrain is desirable; it should be relatively free, but not necessarily clear of obstacles. Obstacles on a DZ will not prevent paratroopers from landing but will increase jump

casualties. Sites in mountainous or hilly country with large valleys or level plateaus can be used for security reasons. Small valleys or pockets completely surrounded by hills are difficult to locate and should be used only in rare cases. Commanders must avoid man-made obstacles more than 150 feet (46 meters) above the level of the DZ within a radius of 3 nautical miles. High ground or hills need not be considered a hazard unless the hills pose an escape problem that is beyond the aircraft's capability. High ground or hills more than 1,000 feet (305 meters) above the surface of the site should not be closer than 3 nautical miles to the DZ for night operations. The perimeter of the DZ should have one or more open approach sectors free of any obstacles that would prevent the aircrew's sighting of the DZ markings.

Cover and Concealment. Cover and concealment near DZs and LZs is a distinct advantage when the airborne forces assemble and when air-land forces land.

Road Net. Having a DZ near a good road net expedites moving personnel, supplies, and equipment from that zone. If the landing area contains terrain that is to be developed into an air-landing facility, a road net is of value—not only for moving items from the facility but also for evacuating personnel and equipment.

Key Terrain. The DZ site selected should aid in the success of the mission by taking advantage of dominating terrain, covered routes of approach to the objective, and terrain favorable for defense against armored attack.

Minimum Construction for DZs and LZs. Because of limited engineer support in the airborne force, selected landing zones should have a minimum requirement for construction and maintenance. Unless more engineer support is requested and received, construction and maintenance restraints can limit the number of areas that can be used or developed.

Mutual Support. Commanders should select mutually supporting DZs and LZs which provide initial positions favorable to the attack.

Configuration. The division commander gives guidance on DZ size in OPLANs or

OPORDs. Then unit commanders determine the exact shape, size, and capacity they need.

Shape. The most desirable shapes for DZs are rectangular or round; these permit a wider choice of aircraft approach directions. However, they also require precise navigation and timing to avoid collisions or drop interference.

Size. The DZ should be large enough to accommodate the airborne force employed. One DZ that allows the aircraft to drop all of its load in one pass is desirable. Repeated passes are dangerous because the initial pass can alert enemy antiaircraft and other emplacements. They will be waiting for subsequent drops.

There are certain situations, however, when multiple passes can be used. This occurs mainly when there is no significant AD threat and orbits can be made over areas where enemy antiaircraft systems are not positioned. This applies especially to the seizure of islands where small DZs are the rule. If enough aircraft are available to deliver the force with less personnel on each aircraft, there is no real problem. However, if there are only enough aircraft to deliver the assault echelon in one lift with each aircraft carrying the maximum number of personnel, then the aircraft will have to make multiple passes over the DZ.

A large DZ can permit several PPIs. Although it is desirable to saturate the objective area in the shortest possible time, there is a reasonable limit to the amount of personnel and heavy drop that can be stacked on a single drop zone. Therefore, it can be desirable to use multiple points of impact on a single DZ, provided the drop zone is large enough.

Capacity. The DZ capacity is based on the expected number of units to be dropped and their dispersion pattern.

Orientation. Thoughtful orientation allows the quickest possible delivery of the airborne force into the objective area.

Ideal DZs offset and parallel each serial. (Figures 7-24 and 7-25.) This allows aircraft to share a flight route until they approach the objective area; then they can split at an impact point (release point) for simultaneous delivery on several DZs.

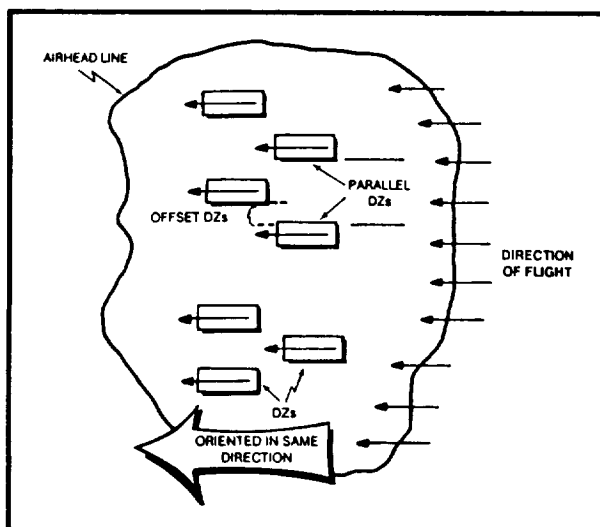

Figure 7-24. Ideal DZ situation

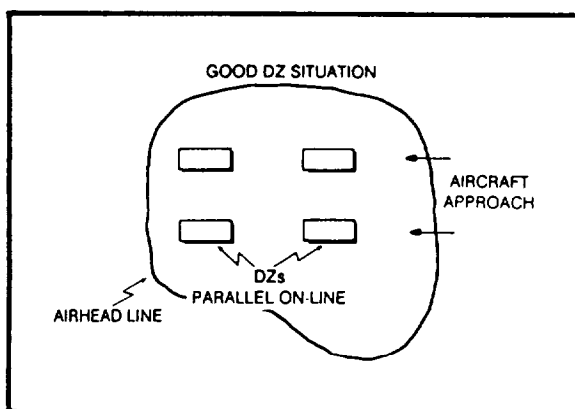

Figure 7-25. DZs parallel on-line

Another technique that can be employed is to make two drops on two DZs in line (thus eliminating a change-of-flight direction between the two drops). The DZs must be far enough apart to permit the navigators to compute the location of the second release point.

Paratroopers are more likely to overshoot the DZ than to undershoot it. Therefore, selection of the trailing edge of the DZ should be at the objective to place personnel responsible for the primary assault objective at the front of the aircraft so that they exit last.

If a fighter aircraft escort or rendezvous is required for the drop, the aircraft must be kept advised of the drop pattern, the direction of all turns

to be flown around the DZ, and the areas to look for possible enemy activity.

Drop zones which require intersecting air traffic patterns should be avoided whenever possible. They delay simultaneous delivery of the force because of the safety requirements to stagger delivery times and clear the air by at least a five- or 10-minute formation separation time. They also require that JSEAD be accomplished for multiple routes instead of one. They may result in piecemeal delivery and an unnecessarily complicated plan, violating the principles of mass and simplicity.

Alternate Drop Zones or Landing Zones.

Commanders must select alternate DZs or LZs to compensate for changes that may occur.

Number of Drop Zones or Landing Zones.

The number of DZs to be used by the assault parachute element of an airborne infantry brigade depends on the number, size, and relative position of suitable sites; the brigade plan of maneuver; and the expected enemy situation. The battalions of a brigade can land successively on the same DZ, on separate battalion DZs, or on adjacent areas within a single large brigade DZ.

A single brigade DZ on which battalions land successively has these advantages:

- It permits greater flexibility in the plan of maneuver and the plan of supporting fires.

Ž It facilitates coordinating and controlling assault battalions.

Ž It applies the principle of mass.

Ž It makes logistics support easier.

- It decreases the area of vulnerability.

A single DZ also has disadvantages:

- It slows the buildup of combat power.
- It causes later airlift sorties to be vulnerable to enemy air as a result of the loss of surprise.
- It allows the enemy to focus his efforts.

A separate battalion drop zone has these advantages:

- It increases readiness for action by deploying the brigade as it lands.

Ž It reduces confusion on the DZs during the landing and reorganizing.

- It tends to deceive the enemy as to the intention and strength of the landing force.
- It makes capture of the brigade objective easier when there is strong opposition on one drop zone.
- It increases the freedom of maneuver of the assault battalions.

A separate battalion drop zone has these disadvantages:

Ž It makes C2 more difficult.

Ž It reduces flexibility because units are dispersed.

Landing battalions on adjacent areas within a single large brigade DZ has, although to a lesser degree, the same advantages and disadvantages of dropping on separate DZs.

Time of Delivery

No set rule can be prescribed for the timing of an airborne operation. It varies with each situation; however, the airborne force will try to conduct airborne assaults during limited visibility to protect the force and to surprise the enemy. The commander sets the specific time of delivery. However, for the landing plan, times are stated in terms of P-Hour (when the first paratrooper exits the aircraft). The following considerations affect the timing of the operation.

Support of the Main Effort. The airborne assault can be a supporting attack. If so, the time of commitment of the airborne forces in relation to the main effort is usually directed by orders from higher headquarters. It is determined in advance according to the mission, the situation, and the terrain. For example, the airborne force can be committed in advance of the main effort to give the airborne attack an increased element of surprise. It can be committed during the main effort to neutralize specific areas or to block the movement of enemy reserves. It can also be committed after the main effort to assist a breakthrough or to block an enemy withdrawal.

Visibility. Whether to commit the airborne force by night or by day depends on the estimated degree of air superiority, the need for security

from enemy ground observation, the relative advantage to be gained by surprise, and the experience of both airlift and airborne personnel.

Night airborne operations offer advantages. They greatly increase the chance of surprise and survivability and reduce the chance of attack by enemy aircraft during the air movement. They also reduce vulnerability to anti-aircraft fire, conceal preparations for takeoff from the enemy, and reduce the effectiveness of the defender's fires.

Night airborne operations have disadvantages. In zero visibility, they require well-trained soldiers and aircrews to locate the DZ and assemble rapidly. They provide more air and land navigation problems and offer slower rates of assembly than daylight operations. Night operations also reduce the effectiveness of CAS.

Daylight operations provide better visibility both from the air and ground, more accurate delivery, quicker assembly, and more effective friendly fires than night operations. However, daylight operations increase vulnerability to enemy air defense, ground fires, and air attack. They also result in loss of surprise.

Intervals. The time interval between delivery of the assault echelon (P-Hour) and the follow-on echelon depends on the availability of aircraft, the capacity of departure airfields, the number of aircraft sorties that can be flown on D-Day, the availability of DZs or LZs within the objective area, and the enemy situation.

For example, if there are unlimited aircraft, ample departure airfields, numerous DZs or LZs within the objective area, and little or no enemy air defense, the commander could deliver the follow-on echelon immediately after the assault echelon.

Thus, the time interval could be so brief that it would be hard to determine which was the last aircraft of the assault echelon and which was the first aircraft of the follow-on echelon. Regardless of the timing selected, a pattern must be avoided.

Assembly and Reorganization

Success or failure of the mission can depend on how fast the airborne force can regain tactical integrity. The first goal of any airborne assault must be to deliver and assemble all available

combat power as quickly as possible. The sooner soldiers assemble and reorganize as squads, platoons, and companies, the sooner they can rig their equipment and start fighting as cohesive units. How efficiently and rapidly this happens is a direct result of detailed planning, cross loading on the assault aircraft, and assembly on the DZ.

Cross loading of key personnel and equipment is important in rapid assembly. It must be given careful attention in training and on combat jumps. The separation of key personnel is necessary in case any aircraft aborts or fails to reach the DZ. This prevents the loss of more than one key officer or NCO of any one unit. Plans for *heavy-drop loads* must also consider the possibility that one or more aircraft will abort before they get to the DZ, or the equipment will "streamer" in and become unserviceable.

AIR MOVEMENT PLAN

After development, backbrief, and approval of the landing plan, planners begin to develop the air movement plan. This plan is the third step in planning an airborne operation and supports both the landing plan and the ground tactical plan. It provides the required information to move the airborne force from the departure airfields to the objective area. The plan includes the period from when units load until they exit the aircraft. The air movement annex to the OPORD contains the air movement plan.

Joint Planning

Although the Air Force component commander is solely responsible for executing the air movement phase, the air movement plan is the product of joint Army and Air Force consulting and planning. The Army contributes its landing plan and the procedures for the control and disposition of personnel at the departure airfields. The Air Force controls takeoff times and, based on the Army's landing plan, coordinates timing between different departure airfields to ensure the proper arrival sequence at the DZ, LZ, or EZ. The Air Force also designates rendezvous points and develops the flight route diagrams. The combination of METT-T and the orientation of DZs, LZs, and EZs determine the orientation of the flight routes.

Elements

The air movement plan contains the information required to ensure the efficient loading and delivery of units to the objective area in the proper sequence, time, and place to support the ground tactical plan.

The air movement table is the main part of the air movement plan. It includes the following essential elements:

- Ž Departure airfield for each serial.
 - Number of aircraft for each serial.
 - Chalk numbers for each aircraft, serial, and departure airfield. (Aircraft tail numbers correspond to aircraft chalk numbers.)
- Ž Unit identity of the airlift element.
 - Name and rank of each AF serial commander.
- Ž Number and type aircraft.
- Ž Employment method for each aircraft (passage point (PP), heavy drop (HD), CDS, and LAPES).
 - Army unit identity.
- Ž Name and rank of each Army commander.
- Ž Load times.
 - Station times.
 - Takeoff times.
- Designated primary and alternate DZs for each serial.
 - P-Hour for the lead aircraft of each serial (given in real time).
 - Remarks such as special instructions, key equipment, and location of key members of the chain of command.

Besides the air movement tables, the air movement plan also contains the following information:

- Ž Flight route diagram.
- Ž Serial formation.
 - Air traffic control.
- Ž Concentration for movement.
 - Allowable cargo loads (ACLs).

- Airfield maximum on ground (MOG) aircraft maneuver space.
- Aircraft parking diagram.
- Army personnel and equipment rigging areas at the departure airfield.
- Army control procedures during preparation for loading.
- Emergency procedures including survival, evasion, resistance, and escape (SERE), and search and rescue (SAR) planning.
- Weather considerations.
- JSEAD, counterair, and AI considerations.

Types of Movement

The type of movement must be considered when determining how to load the aircraft. Is it nontactical or tactical? Airborne units can conduct nontactical movement to an ISB or REMAB, and then transload into assault aircraft by using tactical loading.

Nontactical movements are arranged to expedite the movement of soldiers and equipment and to conserve time and energy. Maximum use is made of aircraft cabin space and ACL.

Tactical movements organize, load, and transport personnel and equipment to accomplish the ground tactical plan. The proper use of aircraft ACL is important, but it does not override the commander's sequence of employment.

Aircraft Requirements

When the airborne unit deploys, planning guidance from higher headquarters indicates the type of aircraft available for the movement. Based on this information, the unit commander determines and requests the number of sorties by the type of aircraft required to complete the move. The air movement planner must ensure that each aircraft is used to its maximum capability. This is based on the information developed on unit requirements, ACLs, and available passenger seats. Methods of determining aircraft requirements are weight and type-load.

Weight Method

This method is based on the assumption that total weight, and not volume, is the determining

factor. Since aircraft sometimes run out of space before exceeding the ACL, this method is no longer widely used. It has been replaced by the type-load method. However, during recent operations, it was discovered that aircraft can actually exceed their ACL before running out of space. The long distances involved in reaching an objective area, the necessity of the aircraft to circle for extended periods before landing, and the large amounts of fuel needed to sustain the aircraft can result in the aircraft having to reduce its ACL. As a rule, the longer the deployment, the lower the ACL.

Type-Load Method

In any unit air movement, a number of the ACLs contain the same items of equipment and numbers of personnel. Identical type loads simplify the planning process and make the tasks of manifesting and rehearsing much easier. Used for calculating individual aircraft sortie requirements, the type-load method is the most common and widely accepted method of unit air movement planning. It requires consideration of load configuration and condition on arrival at a desired destination, rapid off-loading, aircraft limitations, security requirements *en route*, and anticipated operational requirements. The type-load method, therefore, is more detailed and is used in planning unit movements.

MARSHALING PLAN

After the air movement plan has been developed, backbriefed, refined (if necessary), and approved, the next plan to be developed is the marshaling plan. It supports the previous three plans. The tactical, landing, and air movement plans are used to determine the number of personnel and vehicles to be stationed at or moved through each airfield. The marshaling plan provides the necessary information and procedures by which units of the airborne force complete final preparations for combat, move to departure airfields, and load the aircraft. It also provides detailed instructions for facilities and services needed during marshaling. The procedures in this chapter assist airborne commanders and staffs in planning for marshaling and CSS.

The marshaling plan appears as an appendix to the service support annex of the airborne force OPOD or as an annex to an administrative or

logistics order. The G4 is the principal assistant to the commander for the marshaling plans of specific units. Marshaling begins when force elements are sealed in marshaling areas and terminates when the departure airfield control group (DACG) accepts the chalk at the alert holding area. Procedures are designed to facilitate a quick, orderly launching of an airborne assault under maximum security conditions in minimum possible time.

Preparation Before Marshaling

Units complete the following preparations before marshaling—especially for airdrops. Last-minute marshaling activities include briefing personnel, inspecting, preparing airdrop containers, issuing rations and ammunition, and resting.

As soon as a unit is notified of an airborne operation, it begins the reverse planning necessary to have the first assault aircraft en route to the objective area in 18 hours. The *N-Hour sequence* contains the troop-leading actions that must take place within a flexible schedule, ensuring that the unit is prepared and correctly equipped to conduct combat operations on arrival.

Rehearsals are always conducted at every echelon of command. They identify potential weaknesses in execution and enhance understanding and synchronization. Full-scale rehearsals are the goal, but time constraints may limit them.

Movement to Marshaling Area

Unit marshaling areas should be located near departure airfields to limit movement. Higher headquarters can either control the movement to the marshaling area completely, or it can get a copy of the march table and use it to control the traffic out of the assembly area, along the route of march, and into the marshaling area. Advance parties assign soldiers to areas.

The S4 of the unit to be marshaled notifies higher headquarters on the number of organic vehicles that the unit can furnish to move its personnel and equipment to the marshaling areas. This information and the personnel list furnished by the S3 must be available early enough during

planning to procure any other transportation required for the movement.

When marshaling areas are on airfields, they are temporarily placed at the disposal of the airborne unit's higher headquarters. The air base commander's permission is obtained by the tactical units that must conduct activities outside of the camp area.

Passive Defense Measures

Uncommitted airborne forces pose a strategic or operational threat to the enemy. Concentration of forces during marshaling should be avoided to keep impending operations secret and to deny lucrative targets to the enemy. Dispersal techniques include the following:

- Units *move* rapidly under cover of darkness to dispersed marshaling areas near air facilities.
- Commanders *control* movement to loading sites so most personnel arrive after the equipment and supplies are loaded on the aircraft.
- Commanders *prepare* for loading before arrival at the loading site.
- Commanders *avoid* assembling more than 50 percent of a brigade at a single point at any time.

Dispersal Procedures

The degree of dispersal is based on an intimate knowledge of the operation's problems and what is best for the overall operation. Regardless of the dispersed loading procedures, the airlift commander ensures that aircraft arrive over the objective area in the order required by the air movement plan. Depending on the situation, one of the following dispersed loading procedures is used.

Movement to departure air facilities moves airborne personnel and equipment to departure air facilities where airlift aircraft may be dispersed. *Movement to the ISB* is another procedure. Before the mission, airlift aircraft fly to an ISB to pick up airborne personnel and equipment. Personnel and equipment are airlifted to dispersed departure airfield the mission originates from these facilities.

A third procedure combines the above two. Airlift aircraft fly to ISBs for the equipment before the mission. The equipment is airlifted to the dispersed departure airfields and the mission originates from these facilities, or airlift aircraft stop en route at ISBs to pick up personnel. Crews load aircraft quickly so that the fewest possible aircraft are at the ISB at one time.

Selection of Departure Airfields

Departure airfield selection is based on the proposed air movement and the capability of airfields to handle the traffic. Marshaling areas near departure airfields are designated after the selection of departure airfields. For any specific situation or operation, one or a combination of the following factors can determine the selection:

- Mission.
- Ž Airfields (number required, location, and type).
- Runway length and weight-bearing capacity.
- Ž Communications facilities.
- Navigational aids and airfield lighting.
- Location of participating units and marshaling areas.
- Ž Radius of action required.
- Vulnerability to enemy action, including NBC.
- Other TACAIR support available or required
- Logistics support available, required, or both.
- Facilities for reception of personnel and cargo.
- Ž Facilities for loading and unloading of personnel and cargo.
- Facilities for dispatch of personnel and cargo.

Selection and Operation of Marshaling Camps

The marshaling area is a sealed area with facilities for the final preparation of soldiers for combat. Commanders select marshaling camps within the marshaling area based on the air movement plan and other considerations. Another way to avoid concentration of personnel is to time-phase the movement of soldiers from their home bases through the marshaling area to the departure airfield, minimizing the buildup of

forces. After departure airfields and marshaling areas are selected, loading sites are then selected near the airfields. The following factors are considered when selecting marshaling areas:

- Ž Distance to airfields.
- Time available.
- Ž Existing facilities.
- Availability of personnel and materials for construction.
- Ž Availability and access of maneuver and training areas.
- Communications requirements.
- Briefing facilities.
- Location of participating units.
- Ž Security or vulnerability to enemy action.
- Logistics support available or required.

Support Agencies

When the airborne brigades deploy and marshaling areas close, the DISCOM acts as the provisional logistics unit at the home station. The theater commander responsible for the AO provides the provisional logistics support unit for the ISB. If a support unit cannot preposition at the ISB, a support unit from the home station command is included in the advance party. Marshaling control agencies assist the airborne and airlift force in the execution of the operation.

To enable the majority of the airborne force to concentrate on preparing for planned operations, support agencies are designated by division headquarters to provide most of the administrative and logistics support. These nonorganic units and certain organic units not participating in the airborne assault are organized into a provisional unit known as the *marshaling area control group (MACG)*. The MACG commander is the principal logistics operator for the deploying force; he executes the logistics plan. Typical assistance provided by this unit includes—

- Transportation.
- Ž All classes of supply.
- Communications.

- Campsite construction, operation, and maintenance.
- Messing.
- Maintenance.
- Rigging.
- Recreation and other morale services.
- Local security personnel to augment the Air Force, when required.
- Health service support.

The *airlift control element (ALCE)* coordinates and maintains operational control of all airlift aircraft while they are on the ground at the designated airfield. This includes aircraft and load-movement control and reporting, communications, loading and off-loading teams, aeromedical activities, and coordination with interested agencies. The ALCE's support function includes activities that relate to the airfield.

The *DACG* ensures that Army units and their supplies and equipment are moved from the marshaling area and loaded according to the air movement plan. The DACG may be a provisional unit or nondeploying element of the deploying force. The deploying force or MACOM commander identifies who executes the DACG support mission.

The organization of the *arrival airfield control group (AACG)* is similar to the DACG's. When personnel, supplies, and equipment are arriving on aircraft and need to be moved to marshaling camps or holding areas, the AACG off-loads them. The AACG may be provided by a unit already located at the arrival airfield or an element of the deploying force that is with the advance party and positioned at the airfield. As EAD forces arrive, an air terminal movement control team (ATMCT) may replace the requirement for an AACG.

Outload Operations

Complex outload operations are more difficult because they are usually conducted at night under blackout conditions. Since most of the airborne units' vehicles are rigged for air delivery, airborne units rely on the supporting unit for transportation during outload. These requirements are closely related to and dictated by the loading plans developed for the operation.

Contents of Loading Plan

Loading preparations are included in the marshaling plan. Loading plans outline the procedures for moving personnel and HD loads from the alert holding area to plane side. They also outline the use of available materiel handling equipment. Loading plans are closely coordinated with the supporting airlift units.

Formulation of Loading Plan

A loading plan is formulated at joint conferences. It contains information about the number of personnel, amount of equipment to be airlifted, ACLs, and general sequence of movement.

Adherence to Loading Plan

Strict adherence to the loading timetable is needed. Loading of equipment and supplies must be completed in time to permit inspection, joint pretake-off briefing, and personnel loading by the designated station time.

Loading Responsibility

Loading responsibilities in the airborne operation are as follows. The airlift commander—

- Develops plans for specific loads and sequence of movement in conjunction with the unit being moved.
- Establishes and disseminates instructions for documenting and manifesting all cargo and personnel.
- Provides instructions for loading and unloading of aircraft and for tie down of cargo.
 - Parks aircraft according to the parking plan.
- Provides loading ramps, floor conveyors, tie downs, load spreaders, and other auxiliary equipment, such as operation ejection equipment.
- Prepares aircraft for ejection of cargo and safe exit of parachutists from aircraft in flight. Cargo to be ejected in flight is tied down by AF personnel.
- Ensures that an AF representative is present to provide technical assistance and supervise the loading unit during the loading of each aircraft.
 - Verifies documentation of personnel and equipment.

- Furnishes and operates materiel handling equipment required in aircraft loading and unloading if the Army unit needs it.

The airborne commander establishes the priority and sequence for movement of airborne personnel, equipment, and supplies. Further, he—

- Prepares cargo for airdrop, air landing, or extraction according to applicable safety instructions.
- Marks each item of equipment to show its weight and cubage and, when appropriate, its center of gravity. Ensures hazardous cargo is properly annotated on DOD Form 1387-2.

- Documents and manifests all loads of Army personnel and equipment.

Ž Directs and monitors movement of ground traffic to the departure airfield or loading area, and accepts delivery at the destination.

- Delivers properly rigged supplies and equipment to the aircraft according to the loading plan.
- Loads, ties down, and unloads accompanying supplies and equipment into and from the aircraft with technical assistance from an AF representative. Cargo to be ejected in flight is tied down and ejected by Air Force personnel.

Ž Assigns chalk leaders for each chalk.

Section IX. MOVEMENT OPERATIONS

Division movements must ensure units arrive at the right place, at the right time, and can accomplish their missions. An infantry division, without augmentation, will field 1,400 or more vehicles, depending on the type of division.

Divisions always execute tactical movements. There are no nontactical movements in a tactical environment, even moving from a sea or aerial port to a corps assembly area. Tactical movements assume enemy contact may occur *en route* or soon after arrival at the destination. The G3 plans and supervises tactical movements.

The division moves in five phases. Phase one includes movement of elements of the reconnaissance squadron, MP company, and ADA and engineer battalions to conduct reconnaissance and prepare the route for movement. Phase two includes movement of C² elements, ground maneuver brigades, DIVARTY, and battalion quartering parties of subordinate units. Phase three includes movement of the division rear CP, and quartering parties of the DISCOM, aviation brigade, and their battalions and companies. Phase four is the movement of the division main body. Phase five is closure of support elements along the march route.

TACTICAL ROAD MARCH

Infantry divisions normally plan, prepare, and execute tactical road marches as part of a

corps or higher echelon operation. The planning considerations for a tactical road march are—

Ž Missions on arrival and dispositions that best accomplish those missions.

Ž Nature and extent of the probable enemy interference.

- Present unit disposition.

Ž Available routes.

- March rates of elements.
- Time intervals between units.
- Impact of darkness or limited visibility.
- Flexibility and vulnerability of the drawn formation.
- Degree of TACON.

The mission following the move affects routes selected as well as organization of the march. Following the tactical road march, units either move into assembly areas or tactically deploy to complete follow-on missions. Selection of routes and march organization must expedite this.

The nature and extent of probable enemy interference impacts on the organization of march units and security operations during the march. For example, an air threat may require repositioning AD assets along the route and at choke points. A threat of route interdiction may require repositioning additional engineer assets

along the route of march. A threat from bypassed units or the threat of ambush may require increased reconnaissance and security forces along routes.

Routes and march organizations should allow units to conduct an orderly move from their current locations to march routes. This allows units to form into march organization and attain prescribed rates of march before entering the march route. Any changes to task organization and unit locations and dispositions should be considered when selecting routes and march organization.

Available routes will impact the march organization. The division normally plans to move on multiple routes to allow more rapid completion of the move, enhance dispersion, and aid security. If multiple routes are not available, the division must adjust its march organization to a single route. The division TSOP should include standardized march organizations for both single and multiple routes. This increases speed and simplicity in planning, preparing for, and executing tactical road marches. It also reduces the time required to prepare and issue orders.

Route planning includes selection of start point and release points. The start point provides all units of a march column a common point for beginning their integrated movement. When the division uses multiple routes, each has a start point. The start point should be easily recognizable on both a map and the ground, but not be in a defile, on a hill, or at a sharp curve. It should be far enough from assembly areas to allow units to organize and be moving at the prescribed rate when they reach it. Units must not move early or late to start points due to congestion.

The release point provides a common point for units to revert to the control of their commanders. Like the start point, it should be a point easily recognizable on both a map and the ground. It should not cause a unit to countermarch or go through other units to reach its area. Guides meet units as they arrive at the release point to guide them into their assembly areas, or units should deploy tactically for the follow-on mission if applicable.

When selecting routes, the G3 must consider using checkpoints and TCPs at critical locations along the route. The G3 uses them to monitor and

control progress along the route or routes of march.

Halts and refueling points must be planned along the route. The G3 must also allow time for refueling, maintenance, and rest halts on long road marches. Rest halts should be on terrain that is large enough to accommodate multiple march units. Alternate (on-order) holding areas should be specified for emergencies. This simplifies moving march units off the route of march should unforeseen events occur. For example, if the enemy interdicts a route, the G3 can direct march units into these holding areas until the route is repaired or they can be directed onto alternate routes. (See Figure 7-26.)

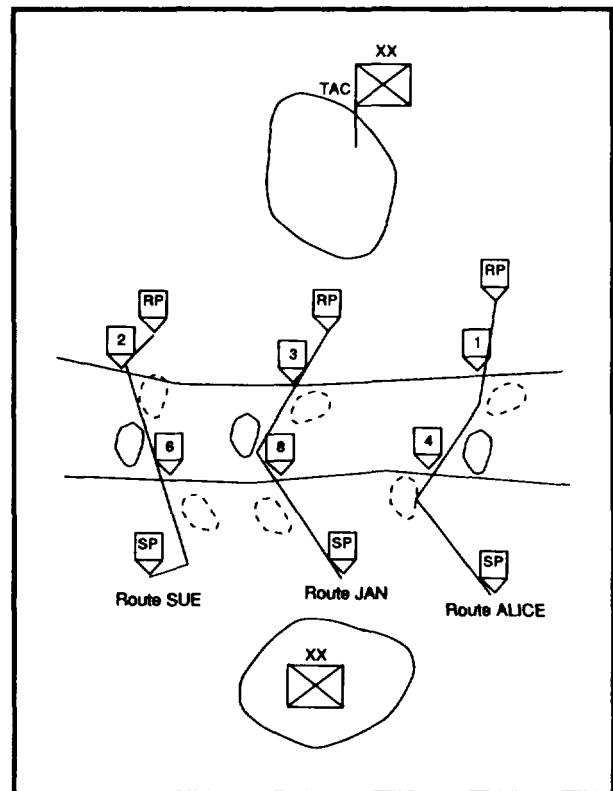

Figure 7-26. March units and holding areas

Rates of march are also important and vary with road and terrain conditions. Wheeled vehicles in column travel at the optimum speed of the slowest vehicles. Factors determining rates of march are—

- Grades, sharp turns, cities, towns, and other route restrictions.

Ž Surface conditions, such as dust, ice, mud, and snow.

Ž Condition of drivers and crews, including their training and experience.

- Condition of vehicles.
- Visibility conditions.

Rates of march for foot troops must be tempered by considerations of soldier load and terrain. As a rule, the total distance marched by soldiers in six hours decreases by 2 kilometers for every 10-pound increase in soldier load over 40 pounds. (See Figures 7-27 and 7-28.)

Average Rates of March for:	On Roads		Cross-Country	
	Day	Night	Day	Night
Foot Troops	4	3.2	2.4	1.6
Trucks, general	40	40 (lights) 16 (blackout)	12	8
Towed Artillery	40	40 (lights) 16 (blackout)	12	8

Figure 7-27. Rates of march

Soldier Load	On Roads		Cross-Country	
	Day	Night	Day	Night
40 pounds	24km	19km	14km	10km
50 pounds	22km	17km	12km	8km
60 pounds	20km	15km	10km	6km
70 pounds	18km	13km	8km	4km

Figure 7-28. Degraded rates of march

A second factor affecting rate of movement is terrain gradient. Distances-traveled may be reduced by half if march gradients exceed 10 percent. Units may exceed these guidelines, but risk a decrease in unit effectiveness. FM 21-18 provides additional information on fast marches.

The G3 controls the march by organizing the division into march columns, serials, and march units. When planning the tactical road march, march units of roughly uniform size should be used.

Infantry battalion packages are the division's basic combat elements and the principal building blocks for tactical planning. They are the first

elements to consider when organizing for movement and should march as serials in nearly equally sized time blocks to simplify planning. Some supporting units may precede the main body to establish refueling points, install communications, and prepare forward bases.

A serial of 55 to 65 vehicles generally corresponds to the size of a light infantry battalion moving in 5-ton trucks and organic vehicles. This 55 to 65 vehicle serial is divisible into company-sized march units. Its size is manageable for CSS commanders, movement planners, and traffic controllers.

Tactical control depends on the chain of command established. The force should be organized into manageable echelons which preserve unit integrity as much as possible. Movement groups, composed of vehicles from more than one unit, must have a single commander.

The TAC CP controls the division road march. It will normally be augmented with division transportation and PM representatives to help control the road march.

The G3 also must consider the type of tactical road march to use—the day march, limited visibility march, forced march, or shuttle march. Each has its own strengths, weaknesses, and planning considerations. Each may be conducted mounted or dismounted.

The division conducts the day march when there is little enemy threat. It permits faster movement and is less tiring for soldiers. Dispersed formations and ease of control and reconnaissance characterize the day march. However, it is more vulnerable to enemy observation and air attack.

The limited visibility march is characterized by closed formations, more difficult C² and reconnaissance, and slower rate of march. However, this type of march provides good concealment from enemy observation and air attack and exploits darkness to gain surprise.

Forced marches are characterized by speed, exertion, and a greater number of hours marched. Forced marches normally increase the number of hours marched rather than rate of march. The division conducts them only when tactically required since they decrease unit effectiveness.

Shuttle marches alternate riding and marching. Shuttling requires transporting troops, equipment, and supplies by a series of round-trips with the same vehicles. It can be accomplished by hauling a load an entire distance and then returning for another, or by carrying successive parts of a unit for short distances while conducting a foot march.

Planning

The G3 has staff responsibility for tactical road marches. The plans element at the main CP plans tactical road movements, and the TAC CP controls the march. The division rear CP supports the main CP during planning and the TAC CP during execution of the march by temporarily providing transportation and PM representatives to help control movement. The rear CP, in coordination with DISCOM and CSS representatives at the main CP, plans and coordinates march logistics support.

March Warning Order

Planning for tactical road marches begins with receipt of the corps order. As soon as possible, the G3 should issue a march warning order alerting units of the impending move. The warning order contains as much information as the G3 can provide. Based on the warning order, major subordinate commanders begin to plan, prepare, and conduct reconnaissance for the march.

Development of plans for the tactical road march follows the planning considerations listed above. Plan development culminates in issuing a road movement or an operations order.

The OPORD contains instructions for movement of units from one location to another within a stated time. Preparation of this order normally follows completion of reconnaissance. When available time and tactical conditions prevent detailed planning or reconnaissance, the division may prepare an initial march plan and issue FRAGOs to modify the plans as needed.

If conditions and time permit, information in the order includes—

Ž Destination and routes.

- Rate of march, maximum speeds, and march order.

Ž Start points and times.

- Halts, vehicle distances, and release points.
- Communications.

Ž Location of the commander.

- Strip maps.

The order also includes route or unit markers, TCPs, and checkpoints.

Staff Responsibilities

The G3 has staff responsibility to plan, prepare, and conduct tactical road marches. He prioritizes and allocates routes and resources, and synchronizes the march.

When corps or a higher headquarters directs the division to move, a corps order normally provides routes, times, assembly areas, and follow-on missions. The G3 plans element, with the assistance of the DTO, develops the division plan. This involves determining priorities of movement and development of movement tables. Use of standard march and task organizations in the divisional SOP can reduce time required to plan, prepare, and distribute orders.

The G3 dispatches liaison teams to units whose AOs include the final location to which the division is moving. Liaison officers obtain information and coordinate movement and terrain requirements.

The G2 conducts an IPB for the march. He identifies possible enemy interference and key terrain for likely interdiction points for the march. With the engineer terrain team, DTO, and PM, the G2 develops and recommends locations of TCPs to the G3. He also presents the effects of terrain, weather, and visibility on rate of march.

The division FSE plans and coordinates tire support for the conduct of the march. It coordinates with the rear CP of units through which the division will move, and obtains existing and planned FS coordination measures. It provides this information to the TAC CP's FSE to coordinate and clear fires during movement.

The ADA representative at the main CP coordinates AD protection with corps and with units through which the division is to move. The air IPB and early warning frequencies and

procedures from those units are key considerations. The division air defense officer recommends AD coverage to protect the division during the march to the G3.

The ADE, working with the G2, corps engineers, and engineer element of units through which the division will march, develops and recommends mobility requirements for the march. These include prepositioning of engineer assets along the march route.

The ADSO integrates communications and information systems requirements to support the march. These include signal support preceding march units for command and control of the march and follow on mission.

The PM coordinates MP support for road movement. This includes placement of traffic control elements to assist in movement through choke points and critical areas where units could easily get lost from their route of march. Military police may also assist in route marking to assist unit marches.

The NBC element coordinates NBC support. This includes NBC route reconnaissance and smoke use in deception or concealment at choke points. The NBC element plans for locations and priorities of hasty and deliberate decontamination points. It coordinates with engineers for route decontamination and the effects of enemy nuclear or chemical attack on primary and alternate routes.

The A²C² element coordinates airspace for the march. This includes use of airspace to support route reconnaissance, aviation brigade displacement, and incorporation of existing and planned airspace coordination measures into the division order.

The rear CP coordinates logistics support. It prepositions CSS assets prior to movement and arranges for support from corps or from units through which the division will march, and HN support. The rear CP also coordinates and integrates civil affairs.

Preparation

Preparation for the tactical road march begins during the planning process. On receipt of the movement order from higher headquarters,

the division begins reconnaissance, dispatches liaison teams to units through which the division will march, and requests required support and supplies from corps. Other preparations include-

- Movement of DTO and PM representatives from the rear CP to the TAC CP.

- Movement of the TAC CP to control the march.

- Dispatch of TCPs.

- Execution of any task organization changes.

- Unit preparations including refueling vehicles, receipt and distribution of supplies, and receipt and integration of any external support into march serials and units.

- Dispatch of communications support packages to support C².

- Dispatch of engineers, maintenance, and, if required, petroleum, oils, and lubricants (POL) support.

- Reconnaissance by unit commanders from their positions to the march start point.

- Dispatch of unit quartering parties or guides.

Execution

The division executes the tactical road march according to its movement or operations order and its SOP. Units move according to the movement tables minus the time required to reach their respective start points. Serial commanders monitor conduct of the march and submit reports to the TAC CP according to the division's SOP, order, and tactical situation.

March discipline is necessary for uninterrupted movement and reduced vulnerability. Traffic control points monitor traffic flow along routes. They report to the TAC CP and adjust the march as directed. For example, march units may be moved into holding areas while routes are repaired or units diverted to alternate routes.

Movement on multiple routes during periods of reduced visibility can increase traffic control problems. Major intersections, defiles, and detours along routes can also add to the problem. The G3 must request additional MP support when — organic assets are not sufficient.

Army aircraft are an efficient means of monitoring tactical road marches. Consistent with tactical security, air control teams can land and control situations until a ground control team arrives.

The TAC CP monitors movement through reports submitted by units and TCPs. Based on the movement or OPORD, the TAC CP commands and controls division movement and submits required reports to the corps. The TAC CP provides information to units through which the division moves. It resolves conflicts and issues instructions as required.

At the release point, guides assist units in clearing the route. The road march terminates when all units have cleared the march route and occupy their assigned positions for the follow-on mission.

Road Movement Table

The road movement table normally is an annex to the movement order. It contains information and instructions on march serials, including their identification serial numbers, rates of march, start points, time for crossing start points, critical points, and other details.

A march column may have difficulty maintaining a constant density, speed, and uniform distance between march units depending on the state of unit training, weather, light, road conditions, and the tactical situation. The addition of a safety time factor to calculations is often necessary.

Standard Infantry Division March Tables

The division uses the infantry battalion as the basic building block for planning tactical road marches. (Foot march planning is found in FM 21-18.) For example, a light infantry battalion has 35 organic HMMWVs. For planning purposes, it is assumed the battalion will have twenty-one 5-ton trucks available to conduct a mounted road march, a total of 56 vehicles. Nineteen other vehicles (from CS and CSS assets) move with the battalion, an average of 75 vehicles. At least 9 of these vehicles operate independently of the road march, either in

advance of it or trailing. The remaining 64 vehicles are subdivided into four 16-vehicle march units.

If road space or time is critical, planners may conduct a detailed road movement plan. A simplified road movement planning formula to expedite movement planning follows. It is based on the following data:

Ž Gap between vehicles is 100 meters for day moves and 50 meters for night or limited visibility moves.

- Rate of march is 30 kilometers per hour for day moves and 15 kilometers per hour for night or other limited visibility moves.

- Pass time for a march unit (up to and including 20 vehicles) is five minutes. (Actual pass time will be less when there are fewer vehicles, but to simplify planning and execution, the five-minute pass time per march unit is used here. This pass time includes a one-minute gap between march units.)

Ž A 5-minute time gap is planned between march units and a 10-minute gap, between serials.

Ž Pass times for serials include pass times of all its march units plus the five-minute gap between serials.

Therefore, a serial with five march units has a pass time of 30 minutes. This is five minutes pass time for each march unit and the five-minute gap following the last march unit and the next serial. (Five march units x five minutes + the five-minute gap.)

Standardized march units for each divisional unit are as follows.

Division HQ	3	Recon Sqdn	2
Inf Bde HQ	2	DISCOM HQ	2
Inf Bns	4	FSB	3
DIVARTY HQ	2	MSB	4
DS Arty Bn	4	Engr Bn	4
GS Arty Btry	2	ADA Bn	6
Avn Bde HQ	2	MI Bn	4
Atk Hel Bn	2	Sig Bn	7
Aslt Hel Bn	2	MP Co	2

The table indicates pass time for each march column. It applies for either day (30 kph) or night (15 kph) marches. To obtain total time, the pass time is added to the time distance factor for the route. For example, if the route is 90 kilometers, the time distance factor is three hours for day (30 kph) or six hours for night (15 kph). (Reference is FM 55-10.) The total time is shown below.

Day	
3 hours 40 min	pass time
+ 3 hours	time distance factor
6 hours 40 min	
Night	
3 hours 40 min	pass time
+ 6 hours	time distance factor
9 hours 40 min	

Standardized march columns on three routes and march units, serials and pass times are as shown in table below. Remaining divisional units are inserted into march columns as required by the situation and movement order. These include division headquarters elements, DIVARTY, DISCOM and the MSB, and remaining portions of the separate battalions.

ASSEMBLY AREA OPERATIONS

The division occupies an assembly area for a variety of reasons. These include preparation for offensive operations, reserve operations, or reconstitution.

The division will be assigned its assembly area by the corps or higher headquarters. The division organizes the assembly area based on the IPB and METT-T. An example of how a division might occupy an assembly area is at Figure 7-29.

The division normally occupies the assembly area task-organized for the follow-on mission. The G3 must ensure that the assigned assembly area contains sufficient space for the division to occupy and prepare for future operations. The division establishes two separate and distinct assembly areas with the assigned division assembly area. These are the division forward assembly area (FAA) and division rear assembly area (RAA). They are normally 10 to 15 kilometers apart. Normally, the clock method will be used for occupation. Division forces occupy the assembly area according to the TSOP. During the occupation of all assembly areas, 12 o'clock is always forward and is the side nearest the enemy. The main CP controls the FAA and the rear CP controls the RAA.

Route One	March Units/Serials	Route Two	March Units/Serials	Route Three	March Units/Serials
Inf Bde HQ	2/1	Inf Bde HQ	2/1	Inf Bde HQ	2/1
Inf Bn x 3	12/3	Inf Bn x 3	12/3	Inf Bn x 3	12/3
DS Arty Bn	4/1	DS Arty Bn	4/1	DS Arty Bn	4/1
FSB	3/1	FSB	3/1	FSB	3/1
Engr Bn	1/1	Engr Bn	1/1	Engr Bn	1/1
ADA Bn	2/1	ADA Bn	2/1	ADA Bn	2/1
MI Bn Co	1/1	MI Bn	1/1	MI Bn	1/1
Sig Bn Co	1/1	Sig Bn	1/1	Sig Bn	1/1
Total: (in each case) 26/10 (3 hrs, 40 min)					

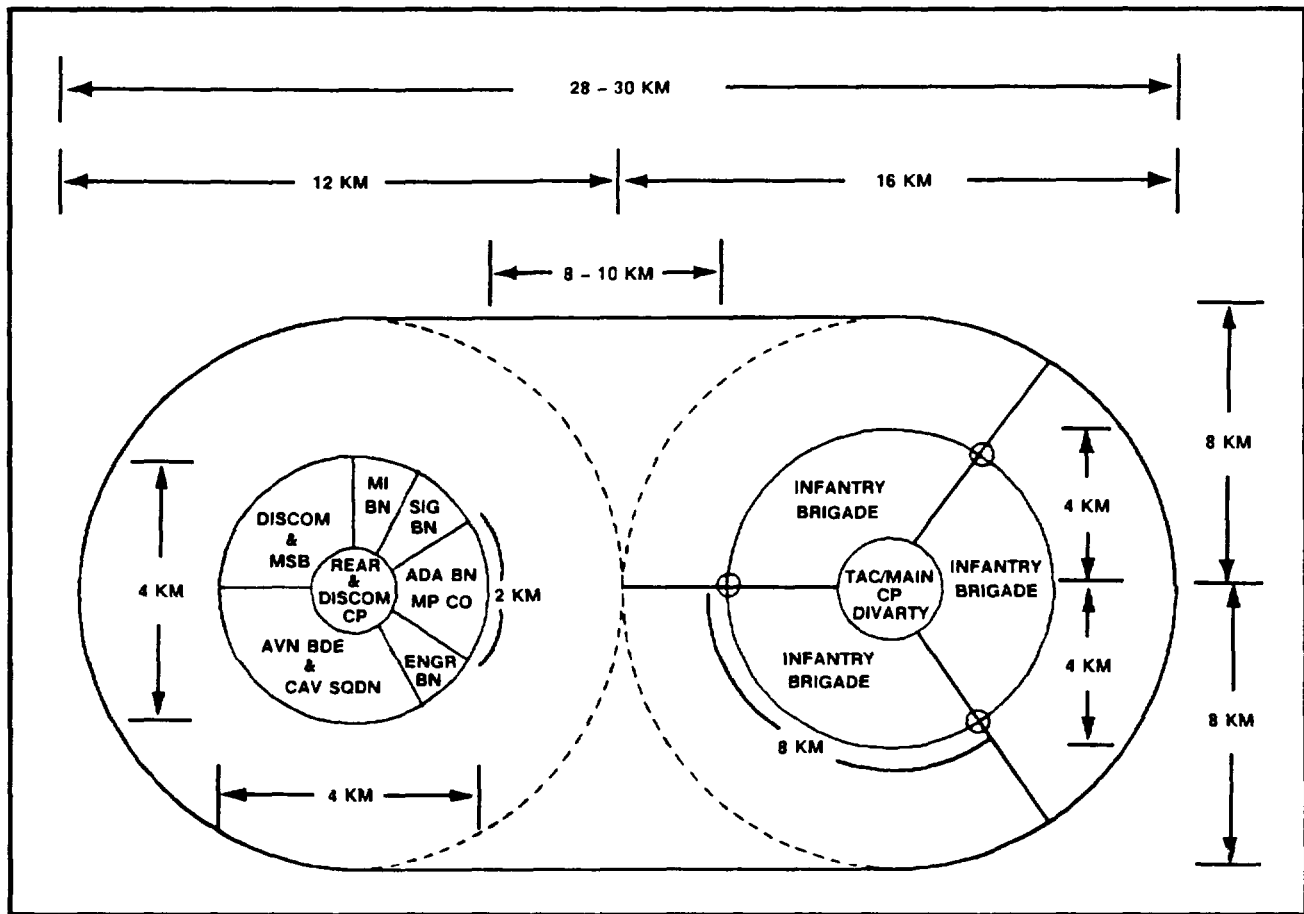

Figure 7-29. Corps-assigned division assembly area

The FM is normally occupied by the following elements.

UNIT	LOCATION
TAC CP and main CP (collocated)	Center Sector
DIVARTY	Center Sector
Inf Bde	10-2
Inf Bde	2-6
Inf Bde	6-10

The RAA is normally occupied by the following elements.

Rear and DISCOM CP	Center Sector
ADA Bn/MP Co	11-1
Engr Bn/Chem Co	1-2
Avn Bde/Cav Sqdn	2-6
MI Bn	10-11
DISCOM/MSB	6-8
Sig Bn	9-10

The division occupies the assembly area in phases as discussed in the previous section on tactical road marches. Guides meet units at release points and direct them to their positions in the assembly area. Units move from release points to their positions in the assembly area without stopping.

Each CP ensures occupying units establish perimeter security. The division plan and graphics establish coordinating points between units to ensure gaps do not exist on the perimeter and to coordinate fire support.

The perimeter of the assembly area can be equated to the FEBA in a defensive sector. This is where elements of the division conduct their close operations. The division's security area is outside the perimeter to the limits of the assembly area assigned by the higher headquarters. In this area

the division conducts counterreconnaissance actions to protect the force from enemy ground reconnaissance and to detect threats.

Routes into and out of the FM and RAA are secured by the units through which the routes pass. The division occupation plan establishes NAIs and assigns surveillance responsibilities. The main CP in the FAA coordinates and synchronizes the security actions of both the FAA and the RAA.

As in rear operations, each unit in the assembly area must be prepared to conduct Level I responses to rear area threats. Both the FAA and the RAA designate a Level II response. The division designates a Level III (TCF) response to significant threats. Division intelligence assets are employed to support the security of the assembly area and support division OPSEC. Ground surveillance radars, communications interceptions, and direction finding systems are employed as part of the counterreconnaissance effort.

The intelligence system also continues to update IPB products for the follow-on mission. The all-source production section continues to coordinate with higher and adjacent units to update the enemy situation. Dependent on the situation, division-level reconnaissance assets may be used to further develop combat information and intelligence for the follow-on mission.

Maneuver forces conduct security operations as directed by the division. If the division is occupying an assembly area in the corps rear, it may be required to provide a response force for corps rear. The main CP coordinates this action with the corps rear CP.

Section X. ARMORED-LIGHT OPERATIONS

This chapter focuses on the use of armored forces in support of the infantry division, specifically an armored brigade supporting an infantry division. Detailed information on armored-light operations is found in FM 17-18.

Employing light units with armored units can be a combat power multiplier. Armored-light unit operations effectively use the infantry division's ability to operate in restrictive terrain, such as urban areas, forests, and mountains. This maximizes the force's survivability and capabilities.

Fire support for the RAA is a concern. The division may position artillery with the RAA to provide responsive fires *or* position artillery, especially 155-millimeter artillery, in the FAA to range the RAA and beyond. Attack helicopters from the aviation brigade in the RAA may also provide fire support to the RAA.

Engineers continually improve survivability positions within the assembly area. They also assist in conducting reconnaissance for follow-on missions. The division engineer and ADE coordinate with higher and adjacent units to ensure the division knows the location of obstacle zones and belts. For defensive operations, the engineers, in coordination with the G2, determine the location and status of enemy obstacles and disseminate this information to division elements.

Air defense of the assembly area is coordinated with the corps AD effort. Divisional FAAD assets are employed throughout the assembly area. Priority is provided to the RAA and the aviation brigade. The AD officer, in coordination with the G2, prepares and coordinates the air IPB. The division positions its FAAD assets and employs them to counter the threat.

Division CSS assets continue to man, arm, fix, and sustain the soldier and his equipment. Depending on the follow-on mission, priority is class V distribution.

The division continues to refine its plan for the follow-on mission. Rehearsals of the follow-on mission are conducted in the assembly area to the extent possible.

The armored-light force should be mutually supporting, based on the commander's concept of employment, to ensure assets of both forces are integrated and synchronized. This chapter discusses the division commander's considerations in planning and executing tactical operations with armored forces.

EMPLOYMENT CONSIDERATIONS

The purpose of employing armored and light forces together is to capitalize on the unique strengths of each type of force while minimizing

its limitations. To accomplish this, commanders must understand the capabilities and limitations of each force and synchronize all combat, CS, and CSS assets.

The augmentation of an armored brigade to an infantry division is a combat power multiplier for the division only if three conditions are met. First, use of the armored brigade must support the division mission. Division commanders must ensure the tactics, techniques, and procedures used by their forces and the armored brigade are compatible. Artillery, engineer, AD, intelligence, attack helicopters, signal, and divisional CSS assets must be properly coordinated with the armored brigade to support armored-light operations.

Second, the armored brigade must bring its own logistics support. The armored brigade should be OPCON to the division. This relieves the division of supporting the brigade. The infantry division's FSBs are not able to support the armored brigade with fuel, ammunition, and repairs.

Third, the commander must remember the differences in tempo between light and armored forces and use these differences to his advantage. Differences in mobility change the way the infantry division fights. The armored brigade's agility allows it to move quickly. It depends on mobility and fire power to survive. Integration of speed and mobility is vital when conducting operations as an armored-light force.

Capabilities and Limitations

The employment of a mixed force must be based on sound METT-T analysis. By maximizing capabilities and minimizing limitations, commanders can effectively integrate armored and light forces. A discussion of capabilities for armored forces and considerations for minimizing limitations follows.

Armored Force Capabilities

Specifically, armored forces can operate as attack or counterattack forces and accomplish rapid movement in exploitations and pursuits. Further, they can-

- Seize terrain and penetrate or envelop enemy defenses or strongpoints.

• Conduct defensive operations by dispersing over great distances and by concentrating rapidly. They can also defend from strongpoints.

• Rapidly exploit success in the offense or defense, including the effects of nuclear, chemical, and conventional fires.

- Conduct delaying actions against larger enemy armored forces.
- Conduct security missions.
- Provide organic air defense against low-altitude hostile aircraft.

Armored Force Limitations

Armored forces depend mainly on radio communications. This makes them vulnerable to EW reconnaissance. However, understanding the commander's intent, doctrine, drills, and control measures for the operations ensures that execution of plans is less disrupted when radio communications break down from jamming or inoperable systems.

Armored forces have a high consumption rate of supply items, especially classes III, V, and IX. Anticipation of these supply needs, integration of supply assets into the BSA at optimum times, and extensive use of LOGPACs can reduce this burden.

Armored forces are vulnerable to antiarmor weapons and mines. Proper integration of dismounted infantry and use of artillery, terrain driving, and extensive reconnaissance to locate and target enemy antiarmor positions and minefields reduce this vulnerability.

Because of the limited number of dismounts available in armored units, these units have difficulty defending positions against enemy infantry. When armored forces are positioned to defend on mechanized avenues of approach, they should be augmented with infantry to reduce this vulnerability.

The armored brigade brings armored protection, mobility, and firepower to the infantry division. The division can use these capabilities to exploit success or reinforce the defense. The integration and synchronization of these capabilities can overwhelm a numerically superior force.

Task Organization

Cross attachment of an armored brigade to an infantry division must be thoroughly considered. Planners must consider the capabilities and limitations of the combined force with respect to the—

- Size and mission of the force.
- Location of the deploying unit in relation to its parent unit.
- Support capability of the deploying force.
- Source of support for the deploying force.
- Self-sustaining capability of the armored force.

Options for task organizing an armored division brigade to support an infantry division are, in priority—

- Separate armored brigade OPCON to an infantry division.
- Armored division brigade OPCON to an infantry division.
- Armored division battalion OPCON to an infantry brigade.

The recommended command relationship for an armored brigade supporting a light division is OPCON. Under this relationship, the division is not burdened with the heavier brigade's logistics support. The division staff must plan for the increased requirements for terrain, movements in the rear area, and for the increased logistics support structure.

When requesting the support of an armored brigade, the division should routinely expect to receive a brigade task-organized as shown in Figure 7-30. The armored division provides additional assets to the armored brigade within its capability. Additional division assets are three heavy equipment transporters (HETs) (3,500 - gallon tankers), two MSE nodes, and one MP platoon. This is the minimum essential organization required to support the infantry division. This is what the parent armored division should provide the armored brigade and still remain capable of conducting and supporting armored division operations. Normally, additional augmentation for the armored brigade comes from corps if the parent armored division is committed.

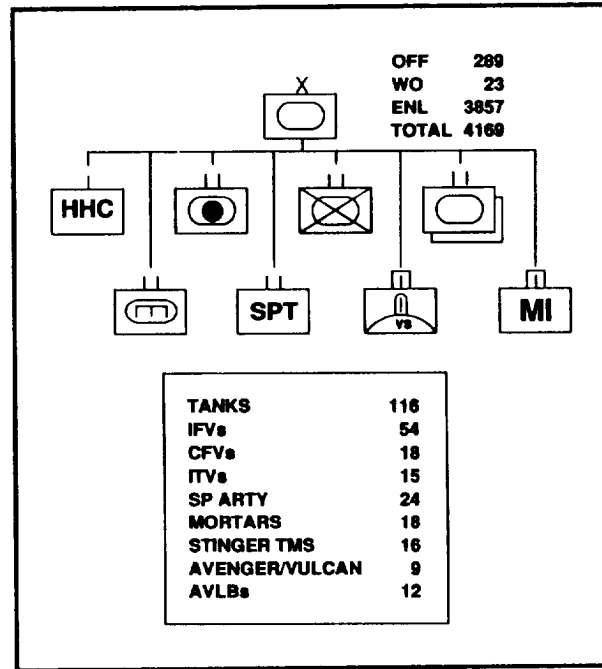

Figure 7-30. Armored brigade

PLANNING CONSIDERATIONS

The effective employment of a force with both armored and light elements requires detailed planning. Mutual planning, development of orders, rehearsals, and coordination between respective commanders and staffs must take place. Critical areas in the planning process include the command and support relationship, composition of CS and CSS support, and effective use of terrain. A common SOP or understanding of each unit's SOP is essential to synchronizing all combat, CS, and CSS units. A discussion of specific planning considerations follows.

Intelligence

Detailed intelligence is critical to the success of armored-light force integration. Intelligence requirements for each force must be understood and integrated into the IPB process. Armored forces orient on unit concentrations, tank and antitank locations, counterattack routes, armor obstacles, EAs, and artillery and AD assets. Both forces' PIR and DSTs must be combined, compared, and explained to both staffs in detail. The R&S plans of both units should be jointly developed and coordinated. The armored force mainly

uses its long-range observation devices to conduct reconnaissance. Armored force systems provide enhanced mobility, range, and protection when contrasted to light infantry assets. These enhancements must be integrated into the intelligence plan.

Maneuver

Either the armored or light force can fix the enemy while the maneuver force attacks. In either case, the armored force requires adequate terrain to maneuver. Some important considerations follow.

Armored forces are best suited to open and mixed terrain. Mobility and organic firepower make it easier for mechanized and armored forces to disperse and rapidly concentrate at the decisive point on the battlefield.

The difference in operational tempo between light and armored units must always be a consideration, including the scheduling of rehearsals. It may dictate an early rehearsal time to allow both forces to take part.

Both units' direct and indirect fires should mutually support each other. The armored brigade can use its long-range direct fires to provide suppression and overwatch fires for the light division. The light division should plan to use the armored force's long-range antiarmor fires. In armored-light operations, differences in equipment may dictate different techniques in marking TRPs.

Fire Support

The armored force must recognize that dismounted infantry operations focus on stealth, which could preclude preparation and other preliminary fires. Planners must integrate available fire support for each force into the fire plan. Planners must be familiar with the organization, capabilities, and limitations of all forces involved. During planning and preparation phases, a liaison team should facilitate the synchronization of fire support. Restrictive fire control measures must be jointly developed and understood by everyone.

Air Defense

Commanders should direct their attention to the ADA resupply requirements. Centralized

planning is required to orchestrate ADA support for armored-light organizations. The division can consolidate ADA units to provide more dense coverage around critical targets. Armored forces provide excellent coverage and capability in air defense and can carry the resupply of Stinger missiles.

Mobility and Survivability

The division G3 and engineer must develop a common obstacle plan, and consider using light infantry to clear choke points and obstacles for the armored force. Division planners must also consider weapons' disparities in range, their impact on prepared obstacles, and use of terrain during battle handoff to an armored force. The priorities of M/S may be different for each force. The light force must be prepared to take full advantage of armored force engineer assets. When light forces breach obstacles for armored forces, planners make sure the breach is large enough for the widest vehicle in the operation.

Combat Service Support

FMs 17-18 and 63-2-1 provide detailed CSS planning information for armored-light operations. CSS requires an understanding of the current, ongoing, and forecasted needs of both forces. Commanders must be able to cross-level CSS to support overall support requirements and be prepared to receive CSS augmentation from the corps support group. The division can coordinate use of transportation assets of the armored force to facilitate this cross leveling. The light division emphasizes replacing parts; the armored unit emphasizes repair. This requires continuous attention throughout the operation. The armored force performs maintenance continuously. The light commander must understand this requirement and provide an opportunity for such maintenance. Also, armored forces can provide the light force with limited water, resupply, and casualty evacuation.

Command and Control

The directing headquarters defines the authority and responsibility within the armored-light force by designating command relationships. The armored and light force must exchange LOs. The planning process is jointly conducted and the development of orders and overlays is

coordinated. Backbriefs are required at brigade level of combat, and at CS and CSS units, to ensure timing, synchronization, and understanding of intent. Standard operational terms and symbols must be used, and codes, recognition signals, and SOIs exchanged. The directing headquarters may need to set up a retransmission site to compensate for the shorter range of the light unit's communications equipment.

Nuclear, Biological, and Chemical

The light division is more limited in its decontamination capabilities than the armored force. The mobility of the light division is affected by the need for soldiers to carry protective clothing in addition to their standard load. The use of armored unit vehicles should be planned to assist in transporting NBC equipment. An armored battalion has expedient devices and water-haul capabilities that can offset light force shortfalls.

TACTICAL MOBILITY

Infantry units use terrain to attack when and where the enemy least expects it and to force him to fight on terrain that puts him at a disadvantage. The augmentation of the infantry with an armored brigade occurs when the infantry commander decides the terrain provides an advantage or an armored brigade is needed to overcome a terrain disadvantage.

The abilities of an armored brigade to move rapidly, penetrate enemy defenses, and kill armor with its firepower are the greatest capabilities it brings to the infantry division.

To obtain synchronization of infantry and armored forces, the infantry commander must coordinate movement of the armored brigade with the maneuver units of the division. He must provide maneuver space for the armored brigade to the objective if it is part of the attack. If it is not possible to attack simultaneously with other maneuver forces, the infantry division commander must decide—

- How much separation to accept prior to the commitment of the armored force.
- How much of the armored force to commit and keep close to the infantry.

- What obstacles or fortifications along the armored maneuver route require infantry to expedite movement of the armored force.

The infantry division can attain increased mobility when it obtains dedicated transportation assets. A discussion of options for providing dedicated transportation follows.

Corps Transportation Assets

The ideal TOE for movement of an infantry division is one light-medium truck company per infantry brigade. This organization has sixty 2 1/2-ton trucks, and ten 5-ton tractors with stake and platform beds. The company has a haul capacity of 1,700 personnel or 1,300 personnel and 276 short tons of supplies in one lift. At approximately 20 passengers per each 2 1/2-ton truck, each infantry battalion could move its companies with 18 trucks (with the other 2 for the support platoon). Of course, tactical expediency may dictate overloading each truck with personnel. This is a METT-T decision based on safety and mission requirements.

The flexibility gained by attaching these companies to an infantry division is extremely important. With this single attachment, the infantry division commander increases his ability to tailor his forces and his tactics.

The infantry division commander can allocate the 2 1/2-ton trucks and stake and platform trucks to synchronize armored-light operations. The only liability is that the infantry division organization cannot support this augmentation. Recovery and maintenance augmentation will be required to support the truck companies. In terms of firepower each truck carries a ring mount and a .50 caliber heavy machine gun. These can be used to provide additional firepower during movement.

Infantry Mounted on a Tank Unit

It is possible to ride infantrymen on the tops of armored vehicles. As a rule, a tank battalion can carry a rifle company of an infantry battalion. Task organizing armor and all infantry provides greater agility and flexibility when committing forces. All tanks have troop-carrying capability; however, strict safety guidelines are essential. (See FM 17-18.)

Mounting infantry on an armored unit is a viable, but a last-resort, solution. Safety is an obvious concern. Continuous exposure to the elements is debilitating to soldiers riding on tanks. Retrograde operations make it difficult to mount and dismount infantry on armored vehicles.

When tanks and infantry must advance or withdraw rapidly, infantrymen may ride on tanks. Infantrymen are extremely vulnerable to antitank, artillery, and small-arms fires and ambushes. It is preferable that infantry ride in trucks or mechanized infantry vehicles. However, commanders can use an armored force to avoid marching dismounted infantry over long distances in emergency circumstances.

Army Aviation

The use of Army aviation assets to move infantry depends on the mission. When a mission requires air assault of infantry, the division may have to request additional aviation assets from corps. Heavy aviation cargo assets support the resupply operations to the armored brigade.

Host Nation Support

If tactical constraints preclude using dedicated transportation, the G5 may be able to arrange for contracting of vehicles under agreements with the host nation.

TACTICAL EMPLOYMENT

Assign complementary missions to each force is the guiding principle for employing armored and light forces. The infantry division can expect to conduct tactical operations with armored units in all combat environments. The most common employment of armored forces by infantry divisions occurs when terrain and vegetation favor use of infantry, but an enemy may have small numbers of motorized, mechanized, or armored units.

Under the proper circumstances, the infantry division normally receives one armored brigade from the corps. The brigade normally comes with additional task-organized maintenance, class III, and class IV.

The armored-light force can conduct a multitude of missions and tasks. (See FM 71-100.)

Examples of offensive and defensive missions and tasks follow.

Armored-light operations in the offense include light missions of movement to contact, attack, and raid which are supported by armored tasks such as reserve, overwatch, counterattack, attack by fire, covering force, and deception. When the infantry division is conducting an attack (Chapter 3), the armored force can support it as a mobile reserve to conduct counterattacks.

During the planning phase of the deliberate attack as described in Chapter 3, the infantry commander perceives the possibility of an enemy counterattack and requests augmentation of an armored brigade to be a reserve or counterattacking force to counter this potential threat. (See Figure 7-31, page 7-68.) The corps commander agrees and augments the infantry division with an armored brigade. The infantry commander positions the armored brigade forward. He coordinates for the rapid movement of the armored brigade with corps and the attacking armored division. If the enemy attacks the initial objectives (FOX and WOLF), the infantry TAC CP directs the armored brigade to positions which will counter enemy efforts. Success depends on the ability of the armored-light forces to ensure the uninterrupted conduct of their air assault to secure river crossing sites and the movement of the corps main attacking force.

Armored-light operations in the defense include light missions of defend, delay, and withdrawal. Armored tasks to support these mission include counterattack, reserve, covering force, overwatch, reinforce, and detachment left in contact.

During the planning of the defense (see Chapter 4), the commander recognizes a weakness in his defense and requests an armored brigade from corps to provide him a reserve. The corps commander agrees with the division commander and augments the division with an armored brigade. The armored brigade is OPCON to the infantry division. The armored brigade is positioned to rapidly counterattack enemy penetrations or to reinforce infantry positions as required, (See Figure 7-32, page 7-68.)

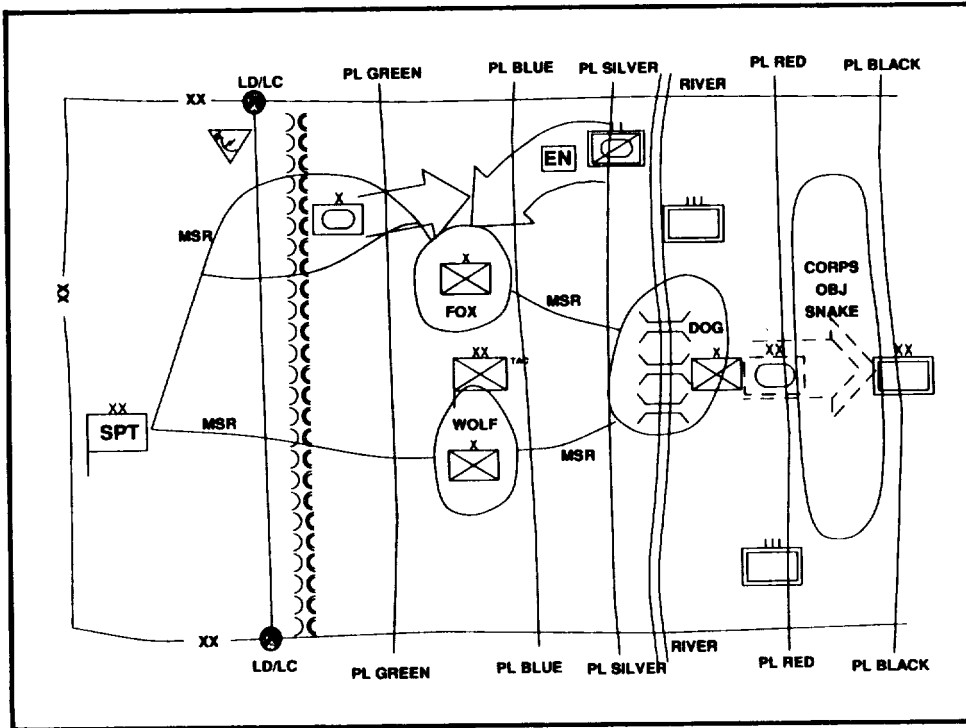

Figure 7-31. Armored-light offensive operations

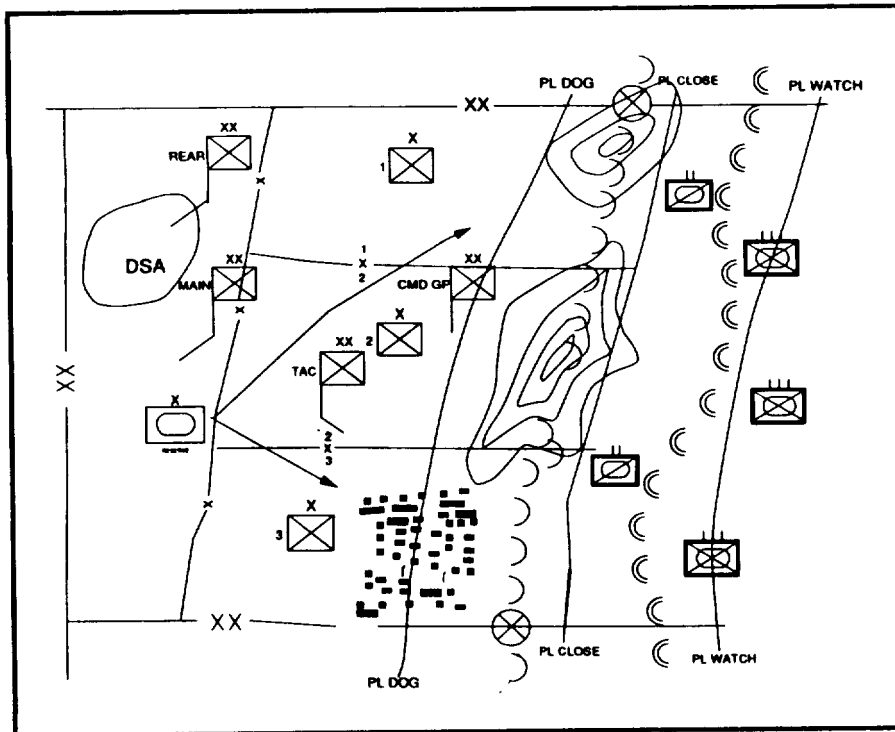

Figure 7-32. Armored-light defensive operations

UNIT ARMORED SYSTEMS

Figures 7-33 through 7-49 illustrate typical systems found in an armored brigade slice. Other pieces of equipment maybe present, depending on the mission and task organization. Knowledge of their organization, equipment capabilities, and limitations is a key element in preparing for battle.

M577 Command Post Carrier

The M577 CP carrier is a full-tracked light-weight carrier used as an operational staff office and command post. It is organic to all armored and mechanized divisions. It is the primary C² vehicle at the division TAC CP. The M577 is intended primarily for operations over cross-country terrain. It is also amphibious and can cross lakes and streams. It accommodates a driver and a four-man team to perform CP functions.

M1 Abrams Tank

The M1 Abrams tank is the Army's primary ground combat weapon system for closing with and destroying enemy forces using mobility, firepower, and shock action. Its special armor, compartmentalization of fuel and ammunition stowage, automatic fire detection and suppression system, and high agility and mobility provide crew protection levels which exceed those of any other tank. The M1A1 Abrams has a 120-millimeter smoothbore cannon, a NBC microclimatic cooling system, thermal sight, laser rangefinder, and full stabilization to provide a combat vehicle capable of operating under all climate and light conditions, as well as in an active chemical environment. (See Figure 7-34, page 7-70.)

M60A3 Tank

The M60A3 is an improved version of the M60 series tank. Improvements include gun stabilization, a laser rangefinder, a solid state computer, and a thermal shroud which enhance its first-round hit capability. A tank thermal-imaging sight extends the fighting capabilities of the M60A3 during periods of reduced visibility. (See Figure 7-35, page 7-71.)

M213 Bradley Fighting Vehicle

Bradley fighting vehicles provide a full-track, lightly armored fighting vehicle for mechanized infantry, and a vehicle for screening, reconnaissance, and security missions for scout and armored cavalry units. Both the infantry fighting vehicle (IFV) and cavalry fighting vehicle (CFV) have two-man turrets which mount the 25-millimeter automatic stabilized cannon, its primary armament, supported by the TOW anti-tank guided missile system, and the 7.62-millimeter coaxial machine gun. The IFV has, in addition, six (M2A2 IFV has only two) 5.56-millimeter firing port weapons positioned along the side and rear of the vehicle. Its mobility is comparable to the M1 tank. The IFV carries a nine-man squad—commander, gunner, driver, and six squad members. (See Figure 7-36, page 7-71.)

M113 Armored Personnel Carrier

The M113 is an aluminum-armored, full-tracked personnel carrier designed to transport troops, equipment, and cargo during combat operations. It has span suppression liners, armored external fuel tanks, an upgraded engine and transmission to accommodate the added weight, and fining points for bolt-on armor. The M113 family of vehicles is used in numerous roles including infantry and engineer squad carrier, mortar carrier, missile carrier, CP, MEDEVAC carrier, and maintenance support vehicle. (See Figure 7-37, page 7-72.) Because of its mobility, firepower, and armored protection limitations, the M113 cannot fulfill the role of a fighting vehicle.

M901 Improved Tube-launched, Optically Tracked, Wire-guided (TOW) Vehicle (ITV)

The M901 ITV is the TOW missile weapon carrier in mechanized infantry units. The M901 is an M113 fitted with an elevating two missile-launcher TOW turret that allows the missiles to be fired from de filade with the gunner under protection.

Lifting arms raise and lower the launcher pod. It incorporates TOW day and night sights as well as a 12-power, target-acquisition sight that can detect tanks at more than 4,200 meters on a normal day. (See Figure 7-38, page 7-72.)

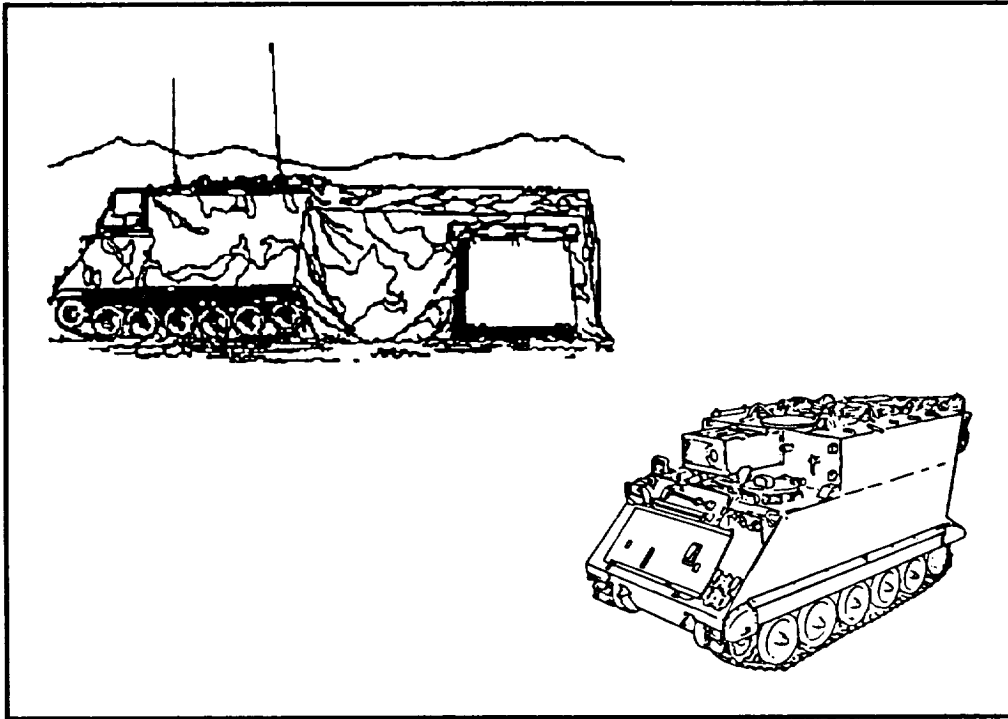

Figure 7-33. M577 command post carrier

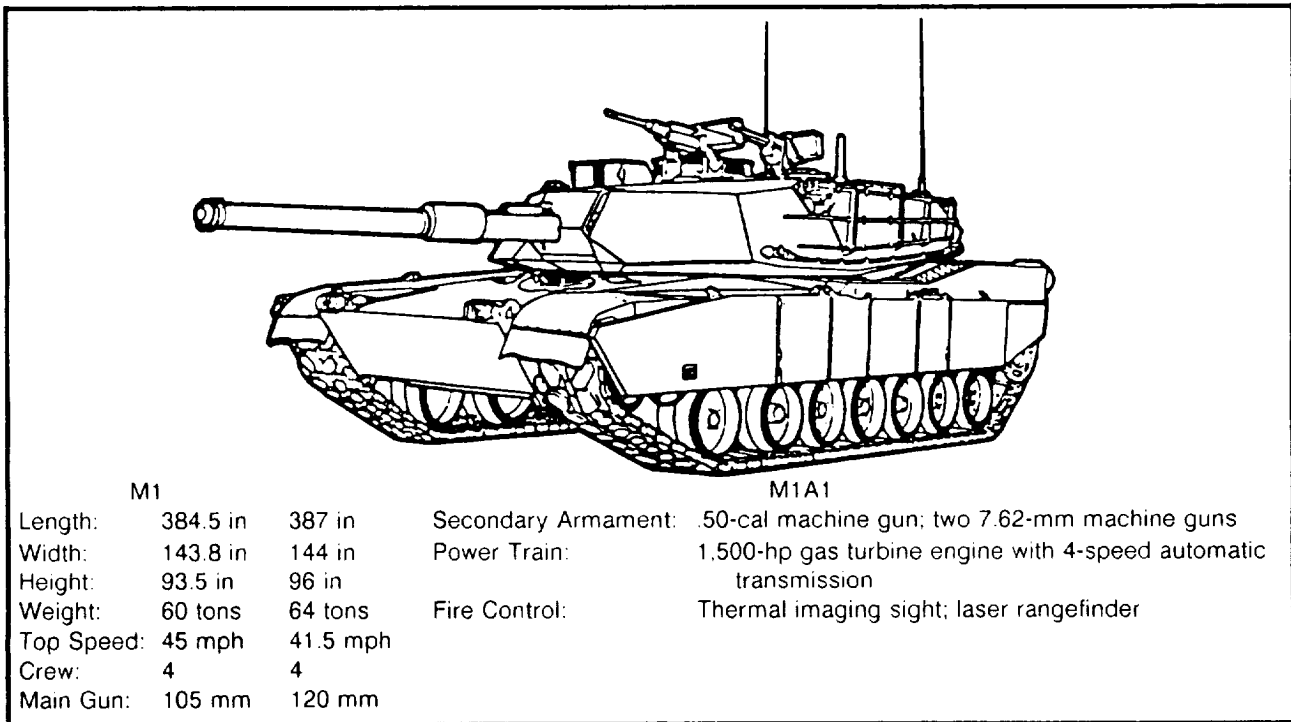

Figure 7-34. M1 Abrams tank

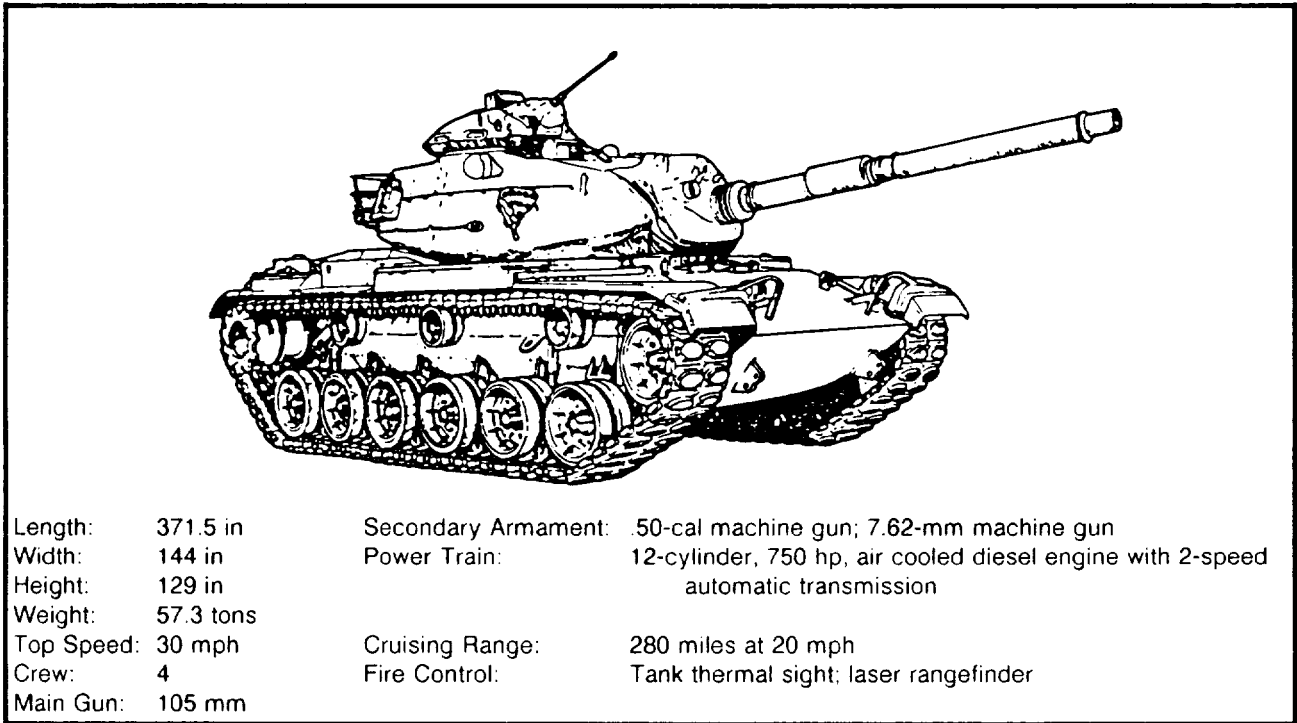

Figure 7-35. M50A3 tank

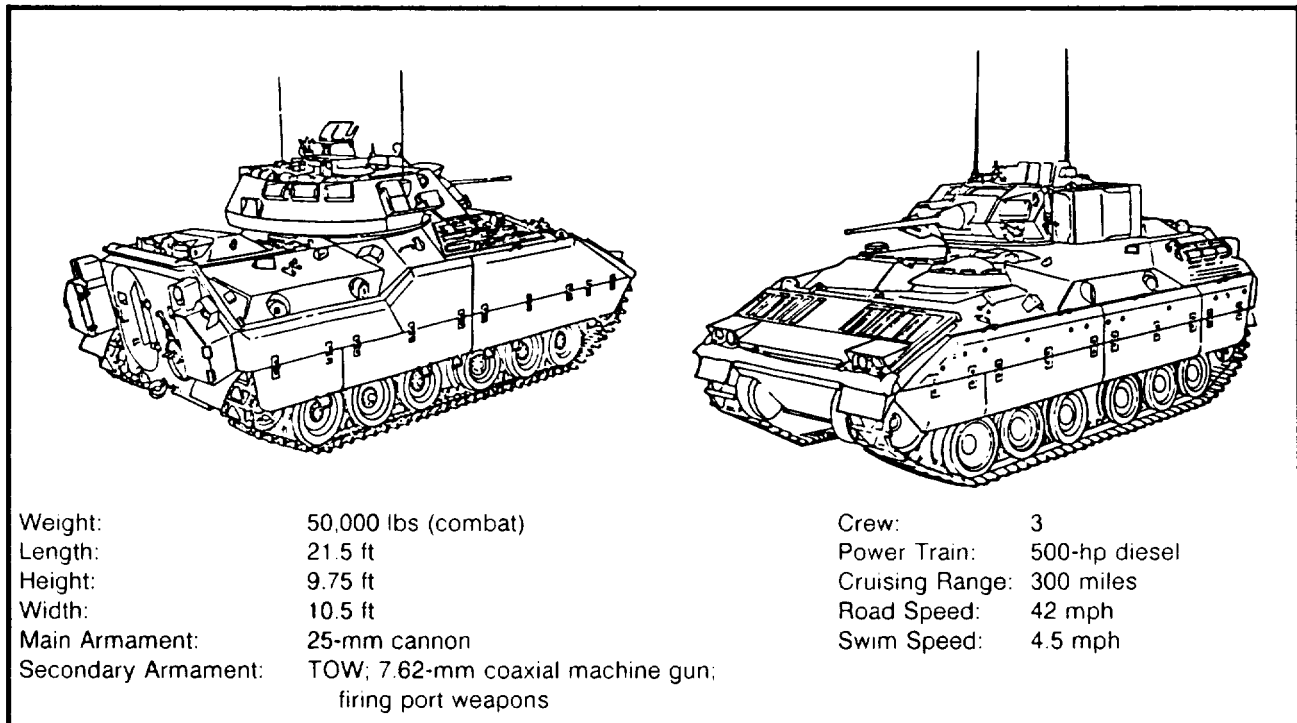

Figure 7-36. M213 Bradley fighting vehicle

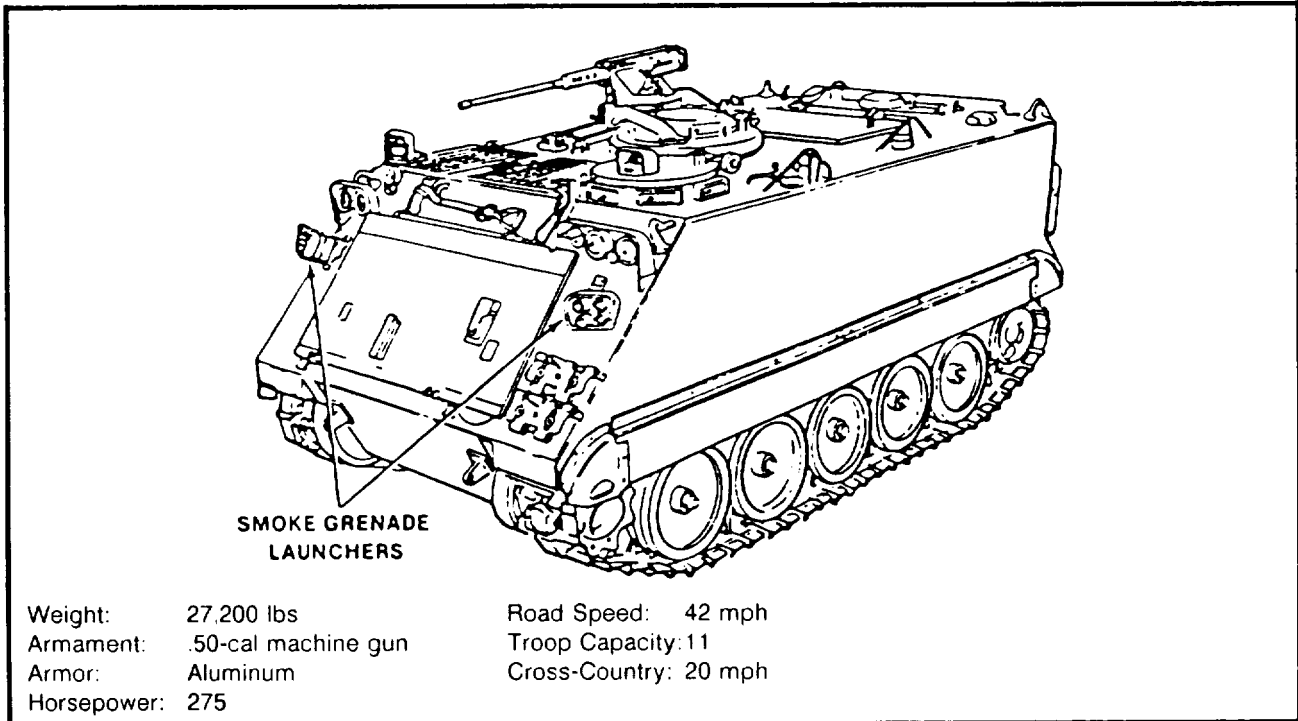

Figure 7-37. M113 armored personnel carrier

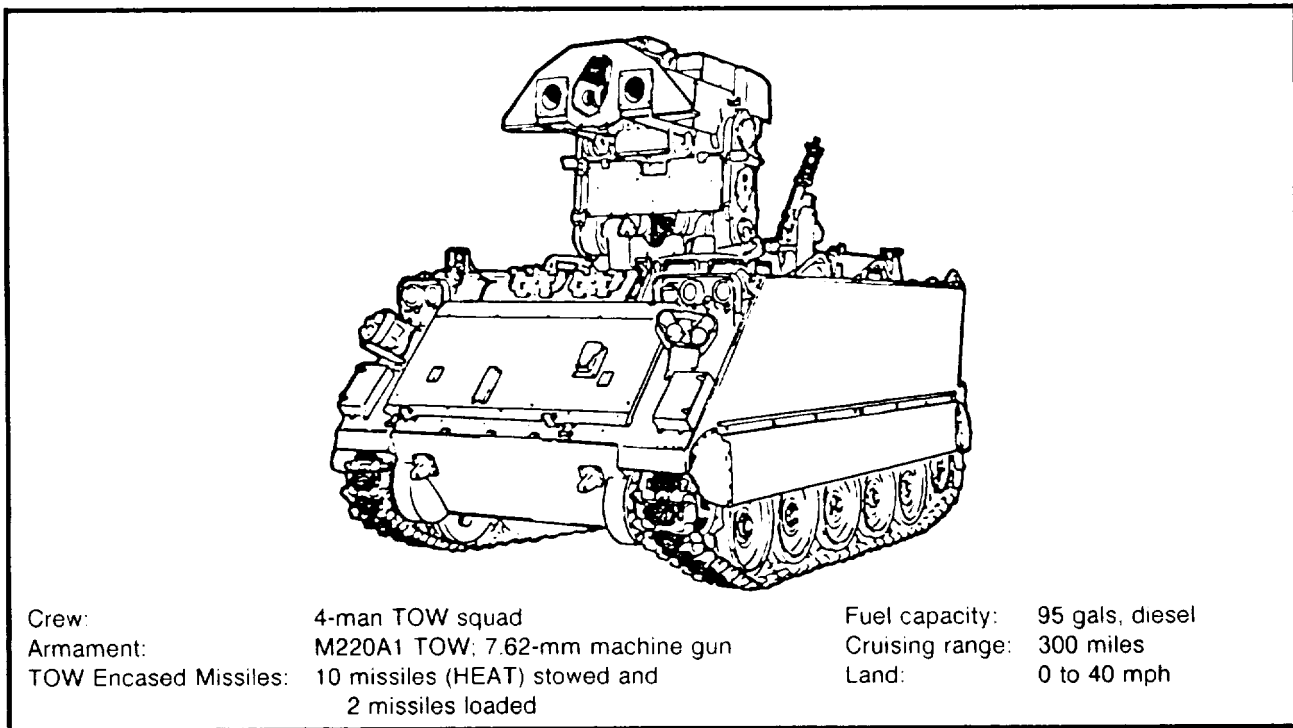

Figure 7-38. M901 improved TOW vehicle

M30 107-millimeter Mortar; M106 Mortar Carrier

The 107-millimeter mortar has a minimum range of 920 meters and a maximum range of 6,800 meters. Ammunition available includes HE, white phosphorus, illumination, chemical, and smoke rounds. The 107-millimeter mortar round provides area coverage of 20 meters by 40 meters. Maximum rate of fire is 20 rounds per minute with a sustained rate of two rounds per minute.

The M106 mortar carrier is an M113 armored personnel carrier modified to carry the 107-millimeter mortar on a specially designed mount. It is an armored, full-tracked, self-propelled vehicle capable of swimming streams and small bodies of water. A .50-caliber machine gun is mounted on the cupola for the vehicle commander's use. The mortar and its components can be removed from the carrier for ground-mount firing. The base plate, bridge, and rotator assemblies of the ground mount are stowed outside the carrier. The M106 has a crew of five and has stowage space for 93 mortar rounds, 54 fuzes, 600 rounds of .50 caliber, and 720 rounds of 7.62 millimeter. The M106A1 carries 88 mortar rounds. (See Figure 7-39, page 7-74.)

M109A2/A3 Self-propelled Howitzer

The M109A2 is an improved version of the M109 self-propelled howitzer. The M109A3 is a depot-modified M109A1 with the same performance capabilities as the production M109A2. The M109 provides primary indirect fire support to the maneuver brigades of the armored and mechanized infantry divisions. The M109A2/A3 can fire both conventional and nuclear munitions. (See Figure 7-40, page 7-74.)

Multiple Launch Rocket System

The MLRS is a free-flight, area fire, artillery rocket system. Its primary missions are counterfire and SEAD. It supplements cannon artillery fires by delivering large volumes of firepower in a

short time against critical, time-sensitive targets. The basic warhead carries improved conventional submunitions. (See Figure 7-41, page 7-75.)

Firefinder Radars—Artillery Locating Radar AN/TPQ-37; Mortar Locating Radar AN/TPQ-36

Firefinder radars locate and bring immediate fire upon enemy mortar, artillery, and rocket-launching positions. Firefinder radars function by spotting enemy projectiles in flight and mathematically backplotting their trajectory. The position of the weapon is reported in grid coordinates fed automatically into artillery fire direction centers, enabling them to target the enemy weapons with guns, rockets, or other ordnance. (See Figure 7-42, page 7-75.)

Bradley Stinger Fighting Vehicle

The Bradley Stinger fighting vehicle (BSFV) is the current line-of-sight forward heavy family of FAAD systems. The BSFV provides short-range air defense to forward area combat elements and other critical assets from attack by low-altitude hostile aircraft. (See Figure 7-43, page 7-76.)

Avenger Air Defense Weapon System

The Avenger is the line-of-sight rear (LOS-R) component for the FAAD system. Avenger converted to MANPAD systems operates forward (in light and special divisions), and a normal configuration Avenger operates in brigade rear areas. In armored divisions, the Avenger platoon should allow the forward divisional AD assets, such as the BSFV, to fight forward to provide depth. The Avenger platoon should be employed to protect critical rear area assets such as maneuver reserves, field artillery, C², and logistics facilities. Avenger can also provide coverage for choke points along the route of march or provide convoy defense for units moving forward. It is imperative that Avenger not become involved in the direct fire fight and disengagement criteria is understood to ensure survivability.

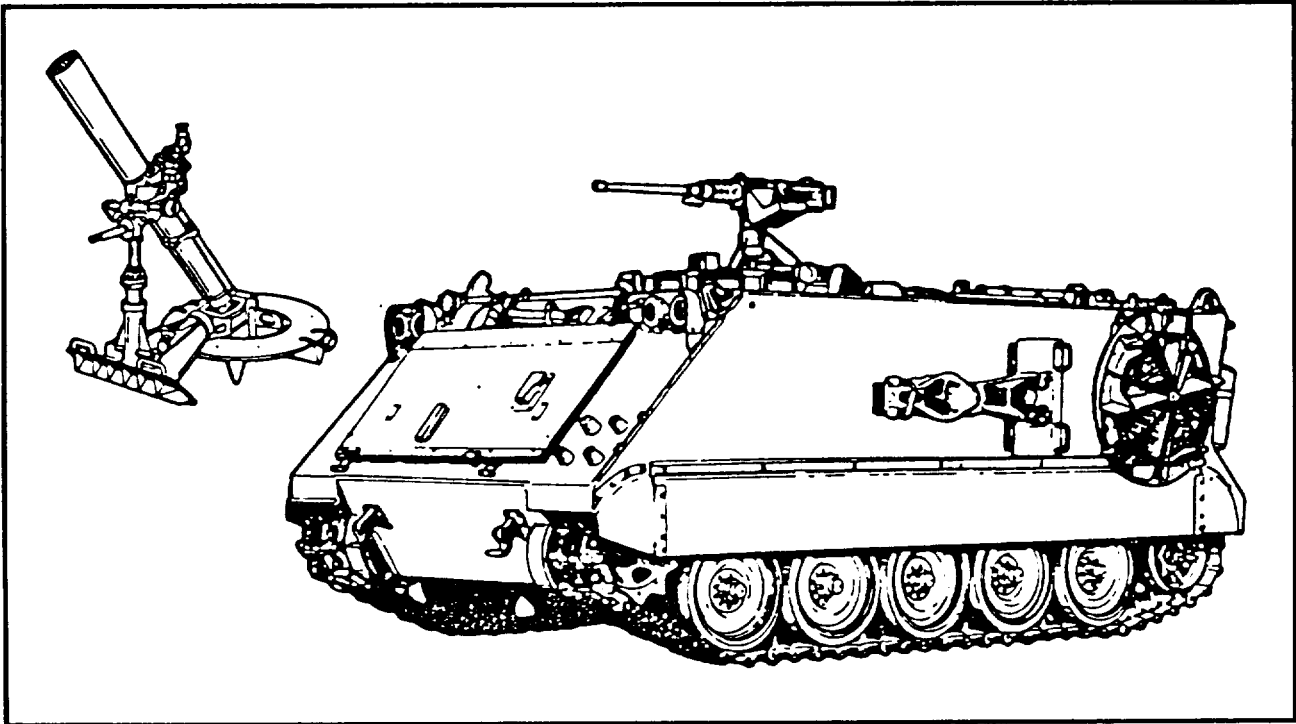

Figure 7-39. M30 107-mm mortar;M106 mortar carrier

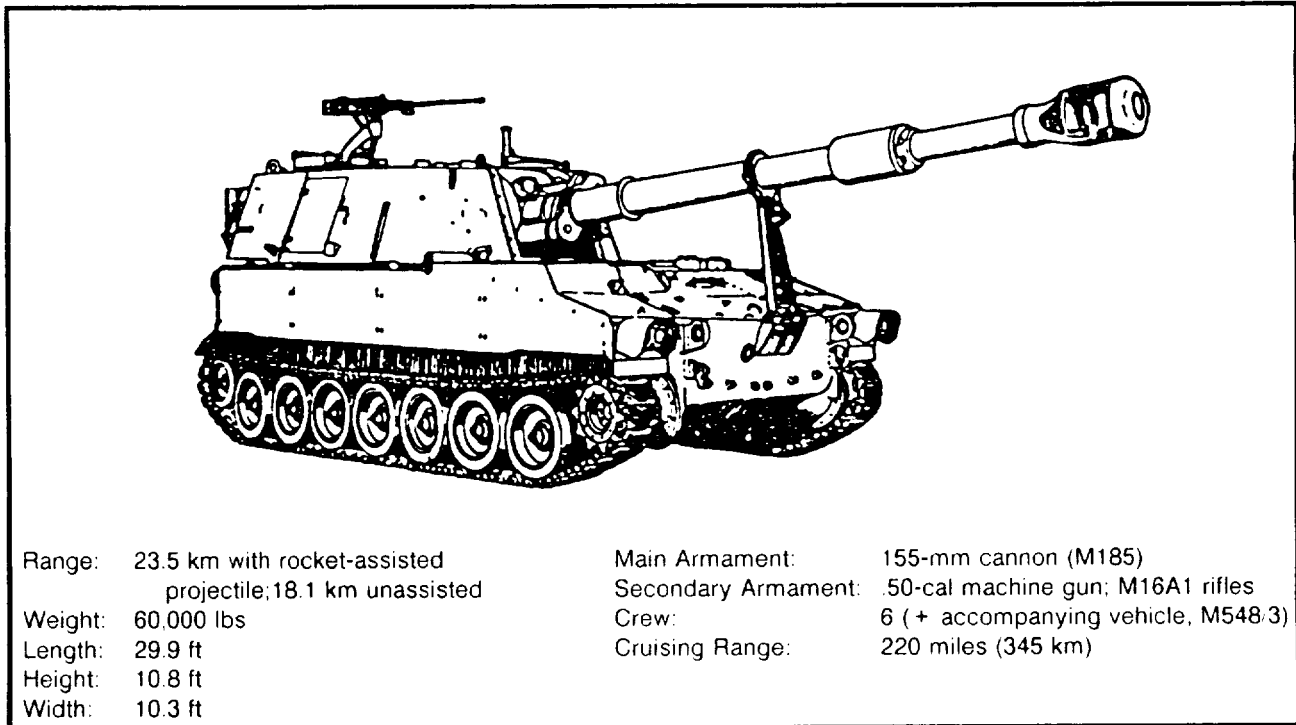

Figure 7-40. M109A2/A3 SP howitzer

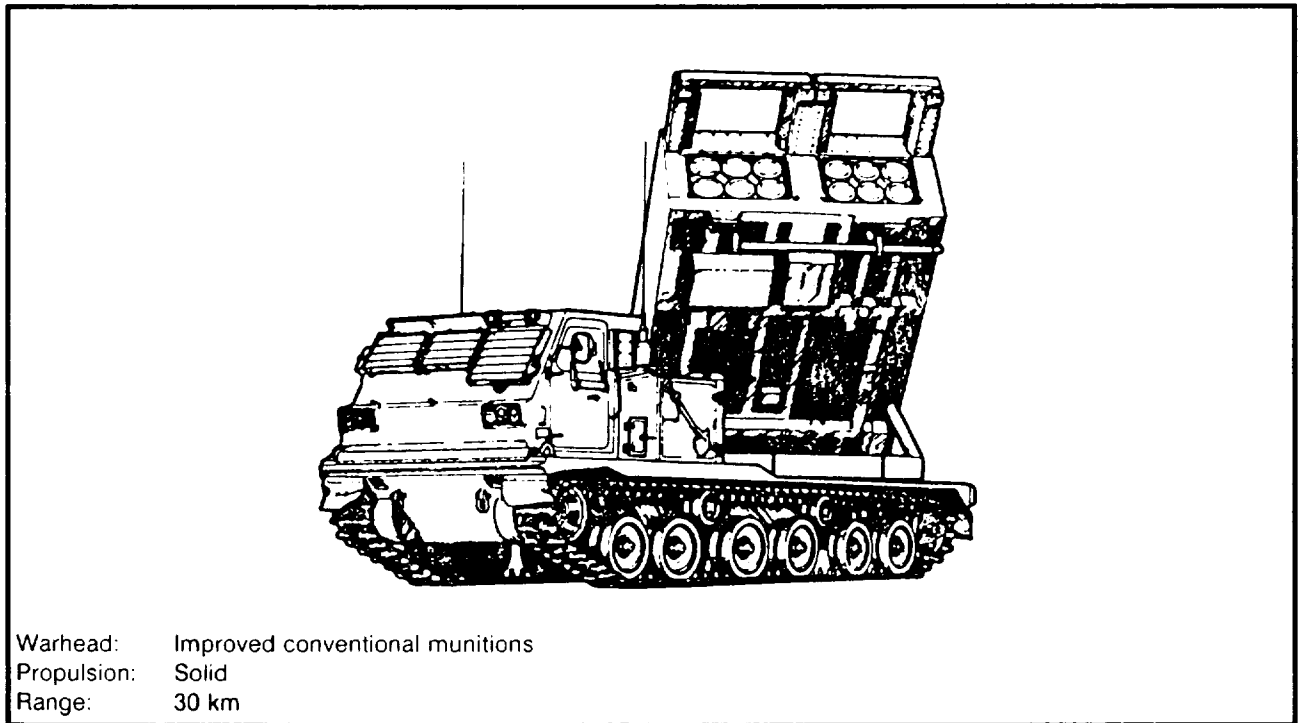

Figure 7-41. Multiple launch rocket system.

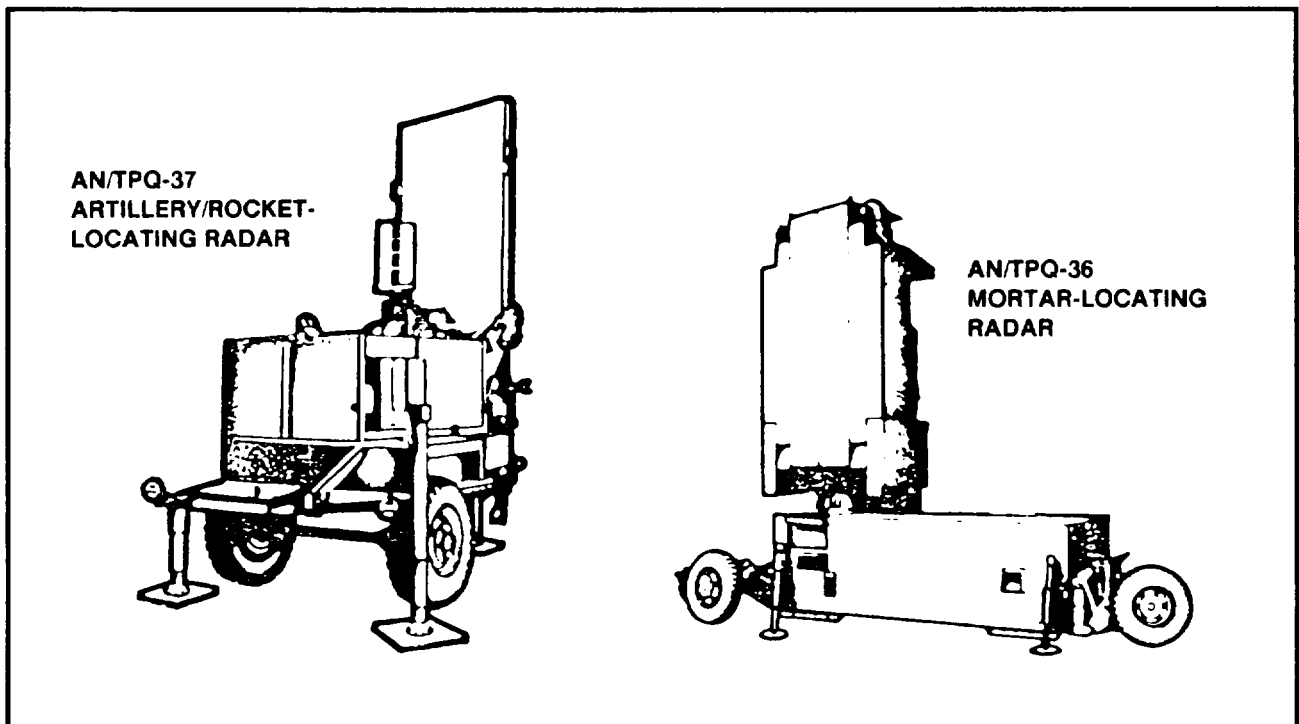

Figure 7.42. AN/TPQ-37 and AN/TPQ-36 Fire finder radars

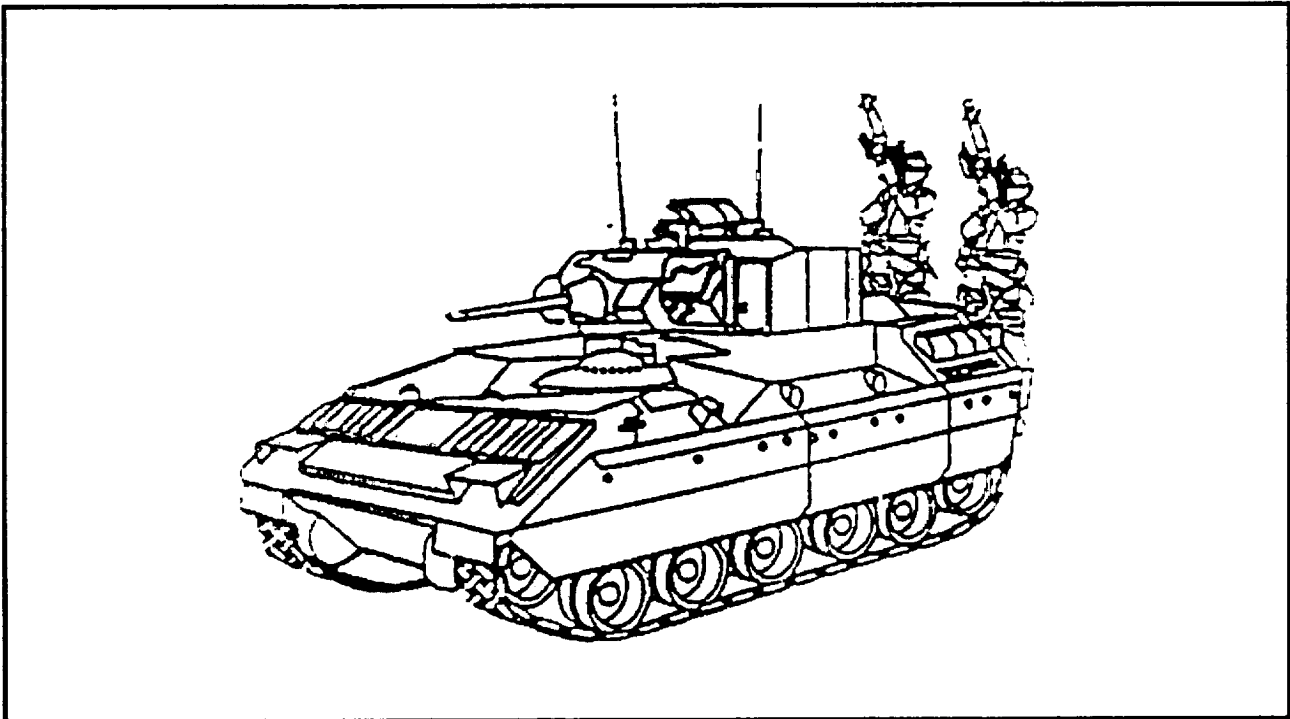

Figure 7-43. Bradley Stinger fighting vehicle

The Avenger team can conduct stationary or mobile operations. Under degraded operations or mission requirements, the Avenger team can revert to a MANPAD configuration. The major components of the Avenger are a rotatable turret with two standard vehicle missile launchers (SVML), a gun system (.50 caliber machine gun), a forward looking infrared (FLIR), a laser range finder (LRF), identification friend or foe (IFF), and a remote control unit (RCU). (See Figure 7-44.)

M113 Mounted Smoke Generator

The armored division chemical company smoke platoon has an organic capability to smoke large areas. The platoon has two squads with three smoke vehicles per squad. There are six smoke generators per squad (see Figure 7-45). This vehicle provides some protection to the crew and gives them the mobility to keep up with mechanized forces.

M9 Armored Combat Earthmover (ACE)

The M9 armored combat earthmover is used for a variety of missions. (See Figure 7-46, page 7-78.) The M9 ACE is a highly mobile, tracked, amphibious, armored, earthmoving vehicle that

can move, survive, and work with the flow of battle, responding immediately to the maneuver commander's need for—

- Elimination of enemy obstacles.
- Creation of obstacles to enemy maneuver.

Ž Preparation of fighting positions for the fighting forces.

Ž Expedient antitank ditching.

- Maintenance of roads and supply routes.

It enables digging, dozing, hauling, scraping, and grading farther forward on the battlefield than ever before.

Armored Vehicle Launched Bridge

The AVLB is used in assault crossings of short gaps by the heavy brigade. (See Figure 7-47, page 7-78.) The AVLB is suitable for spanning narrow streams, antitank ditches, craters, canals, partially blown bridges, and similar obstacles. If the banks and the bottom of a stream or gap permit, the AVLB bridges can be "stacked" to provide 90 to 100 feet of crossing. The AVLB can be used with components of the class 60 bridge to construct rafts.

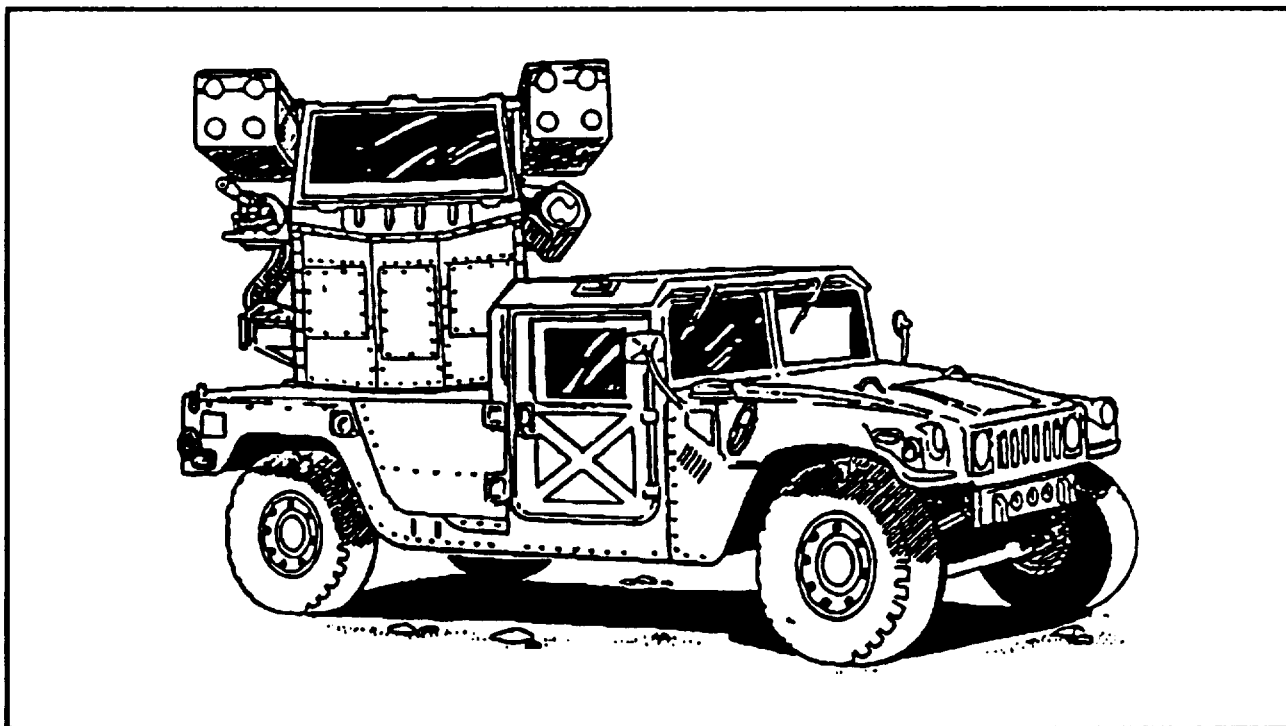

Figure 7-44. Avenger air defense weapon system.

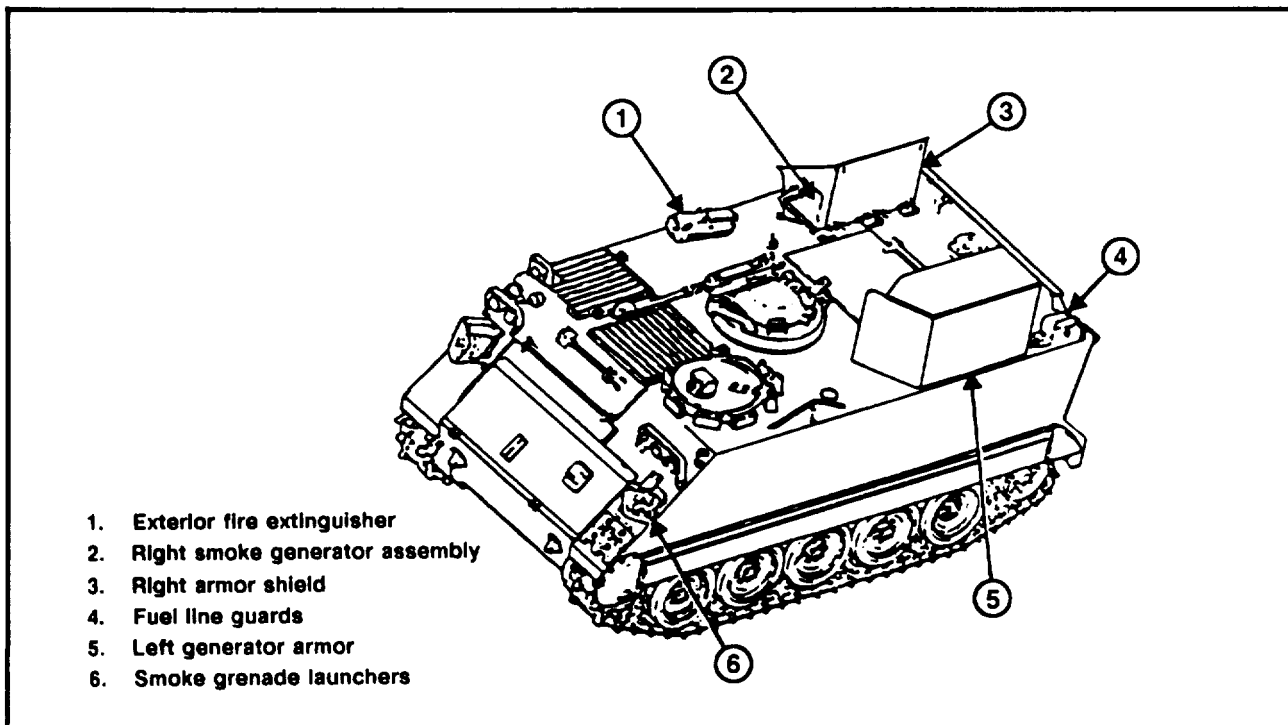

Figure 7-45. M113-mounted smoke generator

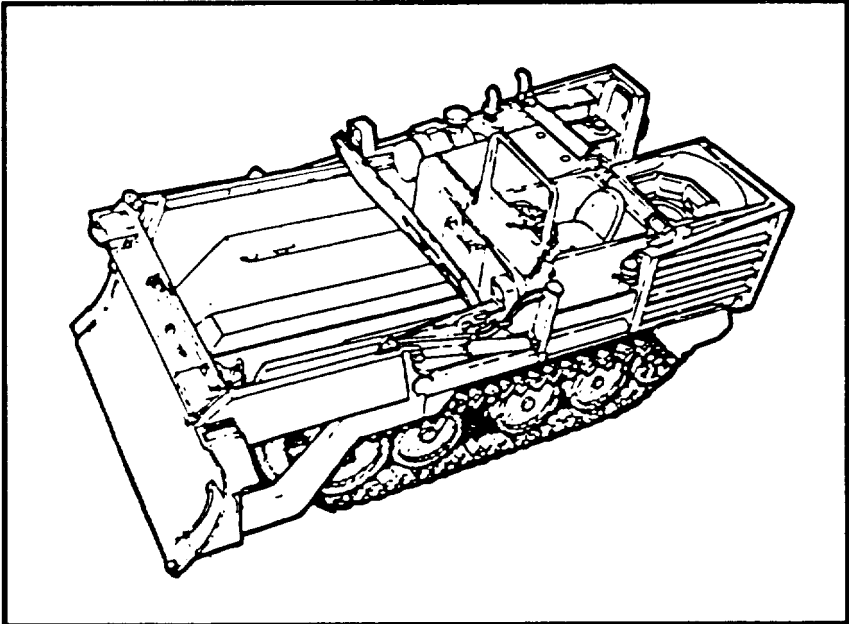

Figure 7-46. M9 armored combat earthmover

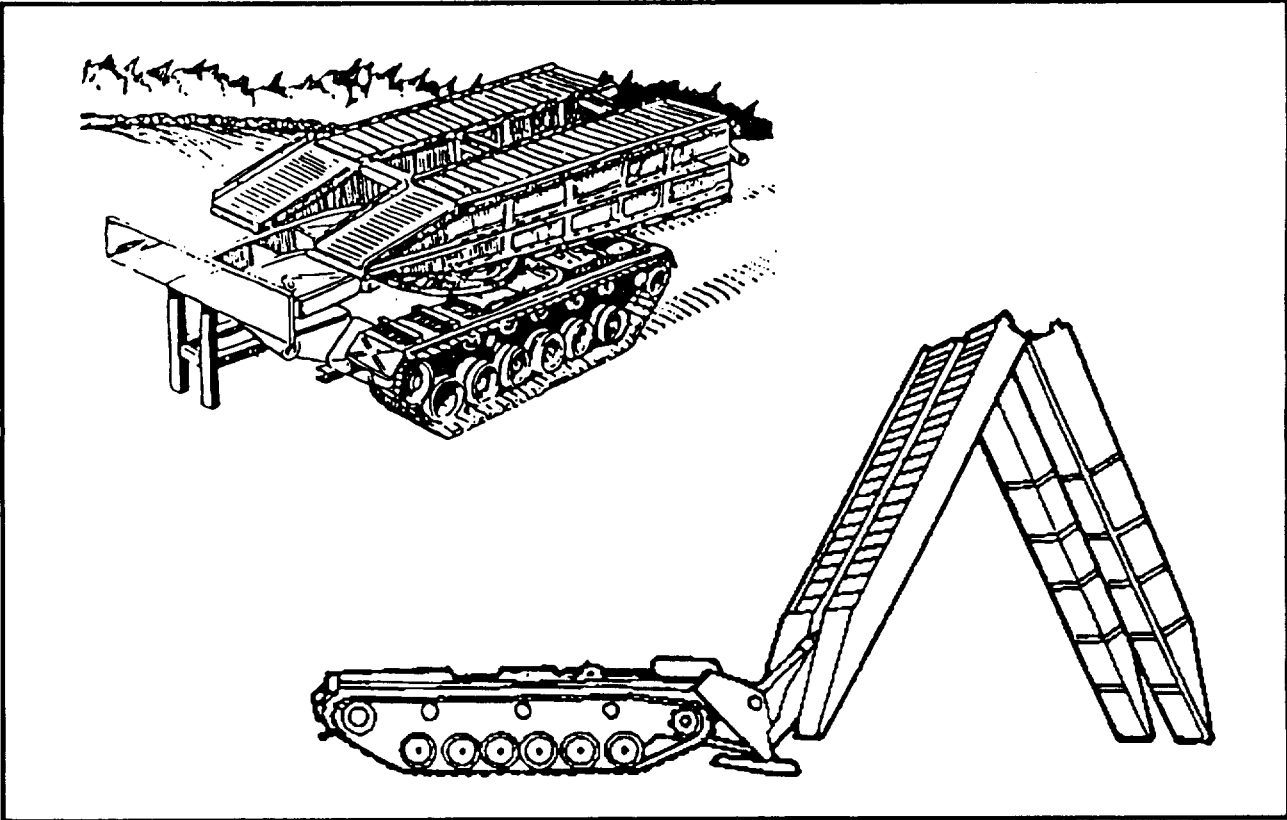

Figure 7-47. Armored vehicle launched bridge

Small Emplacement Excavator

The primary mission of the front loader small emplacement excavator (SEE) wheeled tractor FLU 404 (DSL four with excavator and front loader) (Figure 7-48) is to dig small-sized combat emplacements for crew-served weapons positions and CPs, and individual fighting positions for units in the MBA. It is not well suited for digging in vehicles.

The SEE is a rubber-tired, diesel engine-driven, multipurpose engineer vehicle, equipped with a bucket loader attachment at the front and backhoe attachment in the rear. The SEE has a

hydraulic-driven front end loader, a backhoe, and a family of driven tools, such as a drill, hammer, and chain saw.

Heavy Expanded Mobility Tactical Truck

The heavy expanded mobility tactical truck (HEMTT) is a 10-ton, eight-wheel drive, tactical truck with tandem front and rear axle (Figure 7-49). This vehicle has five body styles: cargo, two types of tractor styles, wrecker, and fuel tanker. The 10-ton HEMTT is an assemblage of commercial components and meets high priority ammunition and fuel transport needs and requirements for the MLRS.

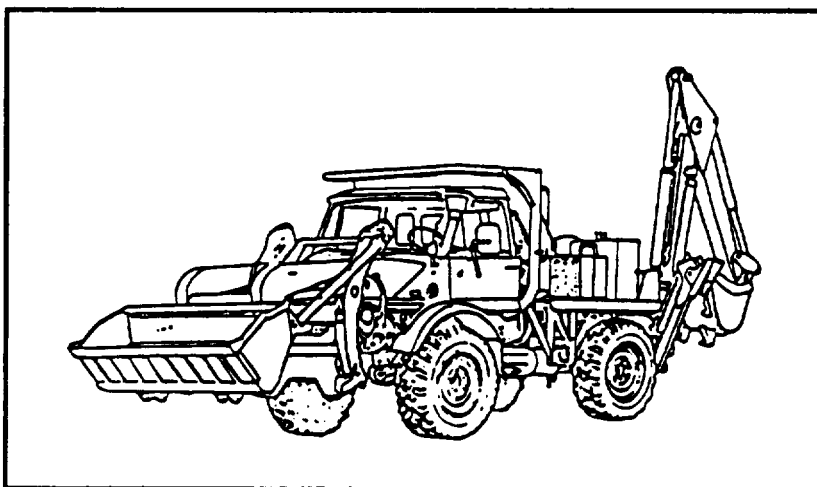

Figure 7-48. Small emplacement excavator

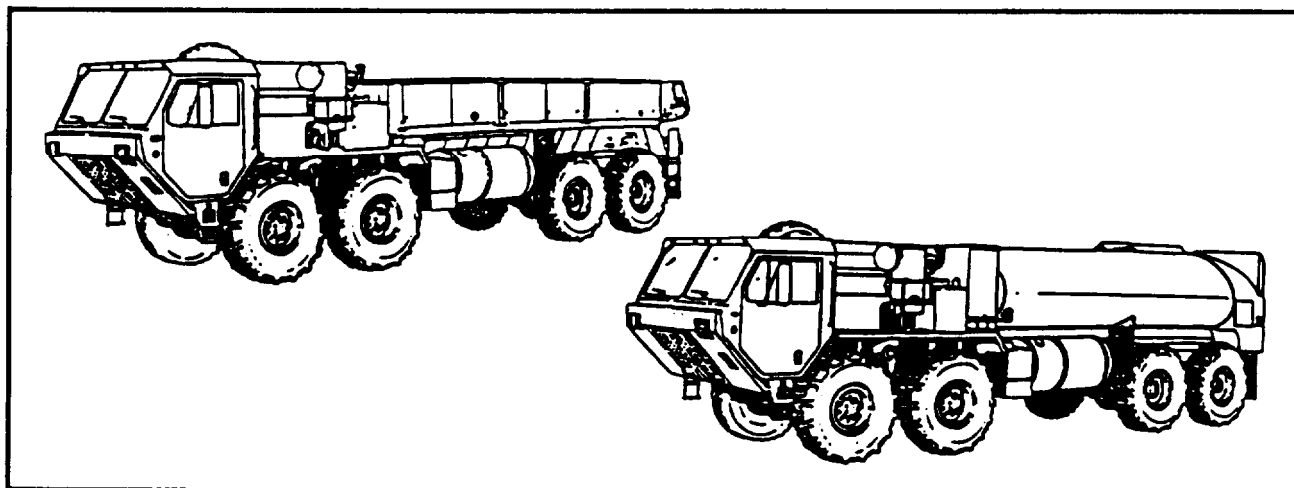

Figure 7-49. Cargo and fuel HEMTT

Section XI. TWO-BRIGADE DIVISION OPERATIONS

The concepts presented in this section apply to a two-brigade division across the conflict spectrum. Higher headquarters' primary concern must be the two-brigade division's mission. A two-brigade division reaches its culminating point sooner than a three-brigade division. FM 100-5 defines a culminating point in terms of an attacking force. However, the principle also applies to the defender. There will come a time when the defending two-brigade division has suffered sufficient losses, extended its lines, or maneuvered back to less beneficial terrain. Then the division has reached its culminating point. It begins to lose cohesion or is unable to defend to the conditions or intent of its original orders—even though it may still be a viable combat force capable of some division-level missions. The corps commander must be aware of this culminating point concept for both the offense and defense when war-gaming courses of action. He must assign appropriate missions with realistic aims and expectations.

Massed and accurate fires are key to destroying the enemy. This is especially true for infantry divisions. The corps must consider providing additional artillery, attack helicopter, and CAS and AI support to the two-brigade division. Fires become the killer mechanism; maneuver forces help create conditions which enhance massed fires. Massed fires can compensate for the lack of a large reserve or a missing maneuver brigade.

This section describes how a two-brigade division may be employed and how it fights. This type of division consists of two organic ground maneuver brigades and appropriate corps DS and GS CS and CSS assets. A third organic maneuver brigade is available.

Functions and systems of divisions with two brigades or three or more brigades are essentially the same. The two-brigade division has two ground maneuver brigades. A three-brigade division fights as a two-brigade division when one of its brigades has been task-organized to another HQ, has been destroyed, or is reconstituted.

Current divisional doctrine missions also apply to the two-brigade infantry division. However, some employment considerations apply only

to the two-brigade division. A two-brigade division fights best when higher headquarters assigns it realistic missions.

Not all two-brigade divisions are task-organized in exactly the same way. A typical two-brigade division has—

- Two ground maneuver brigades with three infantry battalions each.

Ž An aviation brigade with only one AHB in the infantry divisions and three in the air assault divisions.

- A cavalry squadron with two air cavalry troops and only one ground troop.

Ž A DIVARTY with only two 105-millimeter towed battalions, one 155-millimeter towed battery, and a target acquisition attachment.

- An ADA battalion consisting of two AD batteries with nine Vulcans and 20 Stinger teams in each battery.

- An engineer battalion, headquarters company, and two combat engineer companies. (Three is normal.)

- A MI battalion with one—

- Collection company.

- Intelligence and surveillance company.

- Long-range surveillance platoon.

- Quickfix platoon (OPCON).

- A DISCOM with a main support battalion, two FSBs, and an aviation intermediate maintenance (AVIM) company. One task-organized FSB with supporting MSB contact teams and supply and service elements is missing.

MANEUVER

Corps should assign a two-brigade division missions which are consistent with its reduced combat power and flexibility. Such missions should attempt to minimize the two-brigade division's deficiencies and capitalize on firepower and maneuver capabilities. (For example, the two-brigade division loses the flexibility inherent in having a strong reserve.)

Some missions appropriate to the structure and capabilities of the two-brigade division in the offense are—

- Movement to contact (in leading corps in restrictive terrain against dismounted infantry).

Ž Corps reserve.

Ž Supporting attack and feints.

- Follow and support.

Ž Deep operations in support of a corps attack.

Missions appropriate in the defense are—

Ž Corps reserve.

- Area defense in economy of force role.
- Rear area security and counterreconnaissance operations.

Ž Spoiling attack or raids.

Figure 7-50, page 7-82 and Figure 7-51, page 7-83, illustrate concepts of a two-brigade division employed by corps in offensive and defensive operations. Figure 7-52, page 7-84, and Figures 7-53 and 7-54, page 7-85, represent techniques for employing a two-brigade division's maneuver assets.

The division commander must take every advantage of the strengths and synergy of his division. He must make full use of all combat multipliers in combat, CS, and CSS units (organic and supporting). He must form a small, strong, and mobile reserve to provide tactical flexibility and to offset a decrease in ground maneuver combat power. He can best do this by designating the aviation brigade as a maneuver brigade headquarters or augmenting the reconnaissance squadron. Both units have the C² capabilities to become the divisional reserve. Since the division lacks reserve strength, the concept of maneuvering or massing fires is critical for reserve operations. Designation of a small, but strong and mobile reserve is the key to the division's ability to retain flexibility. Rapid massing of air, aviation, and artillery fires at the critical point alters the combat power ratios where the reserve is needed. This compensates for the lack of a large ground reserve.

Techniques for the employment of the two-brigade division are relatively unaffected by the absence of a third brigade. The loss of one-third of the division's maneuver and firepower is in part

offset by simplified C² due to decreased span of control of support requirements.

In the defense, the corps must assign missions based on the enemy and terrain consistent with the two-brigade division strengths. Depending on the situation, the aviation brigade or division cavalry squadron, augmented with an infantry company, may be the best choice to form a reserve or counterattack force. The use of the division cavalry squadron as a reserve must be weighed against other security operations. In all cases, the reserve should be augmented with an infantry unit (battalion and below).

The two-brigade division's deep operations are not different than those of the full division. The principal concern for both is the volume of deep attack missions. Without corps support, heavy reliance is placed on GS 155-millimeter battery, an AHB, and whatever AI sorties are available. Deep attack missions are then scheduled fires or allocated missions rather than having specific assets dedicated to them. The priority of GS fires is close operations' main brigade, deep operations, and then the supporting effort brigade. The division G3 must establish priorities (for example, deep targets which would preempt main effort brigade fires).

When the aviation brigade is designated a maneuver headquarters, the commander must provide the personnel and equipment to plus-up the organization for continuous operations (CONOPS). The aviation brigade, even when augmented, may be limited in its ability to perform CONOPS more than 24 to 72 hours. This is due to maintenance and crew rest requirements, and the possible need to run all aircraft into maintenance phase at once. The division reconnaissance squadron should be augmented with an infantry unit. With only one ground cavalry troop, the squadron cannot effectively perform reconnaissance and security missions. The addition of an infantry company provides flexibility and combat power for ground operations. It provides a stronger economy of force element, maneuver force, or reserve. The two-brigade division commander will have to accept some decrement or risk in rear security, or reserve operations. With limited assets, the focus must be on the close operations. Other areas become economy of force operations.

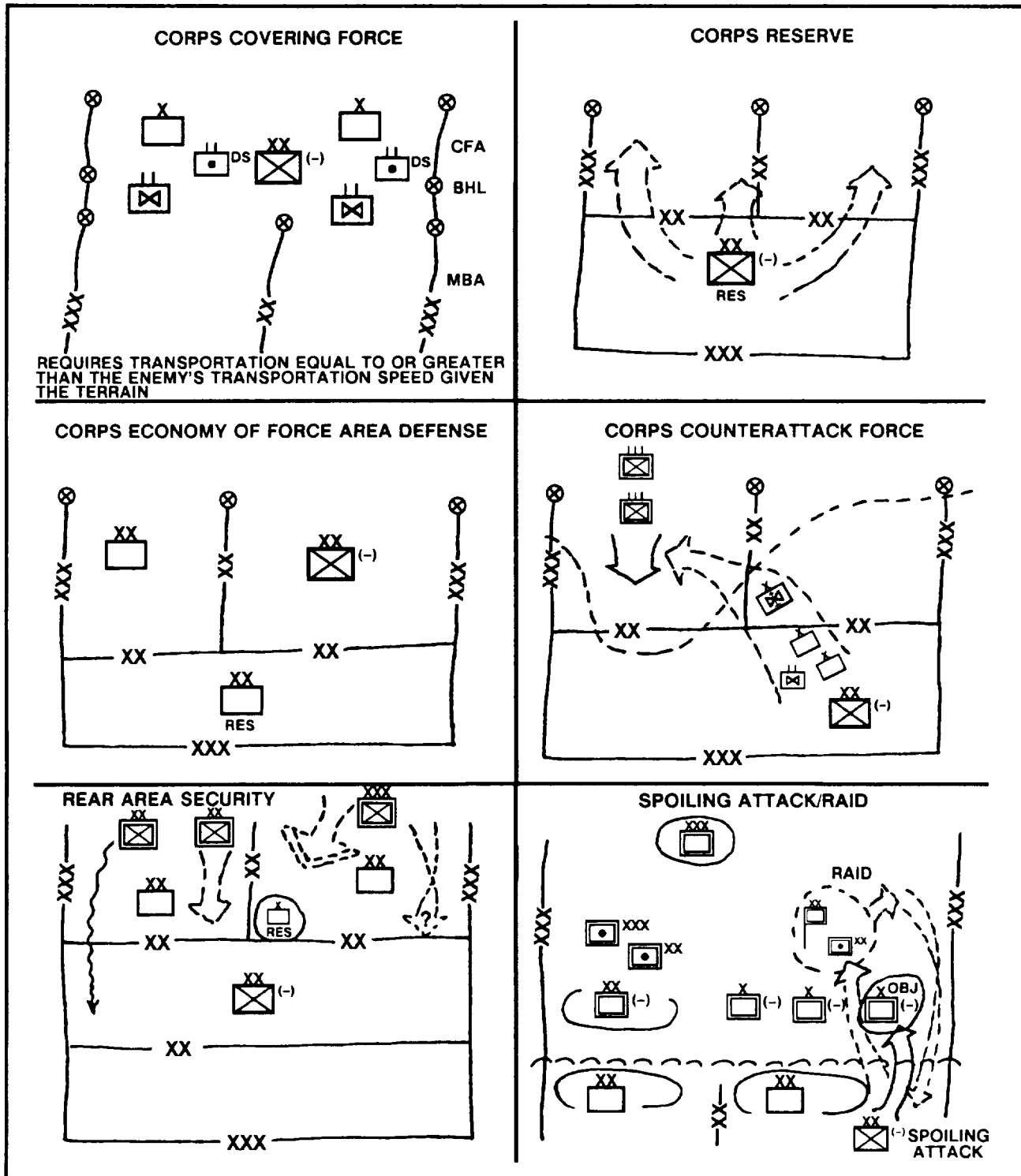

Figure 7-50. Corps defense: two-brigade division missions

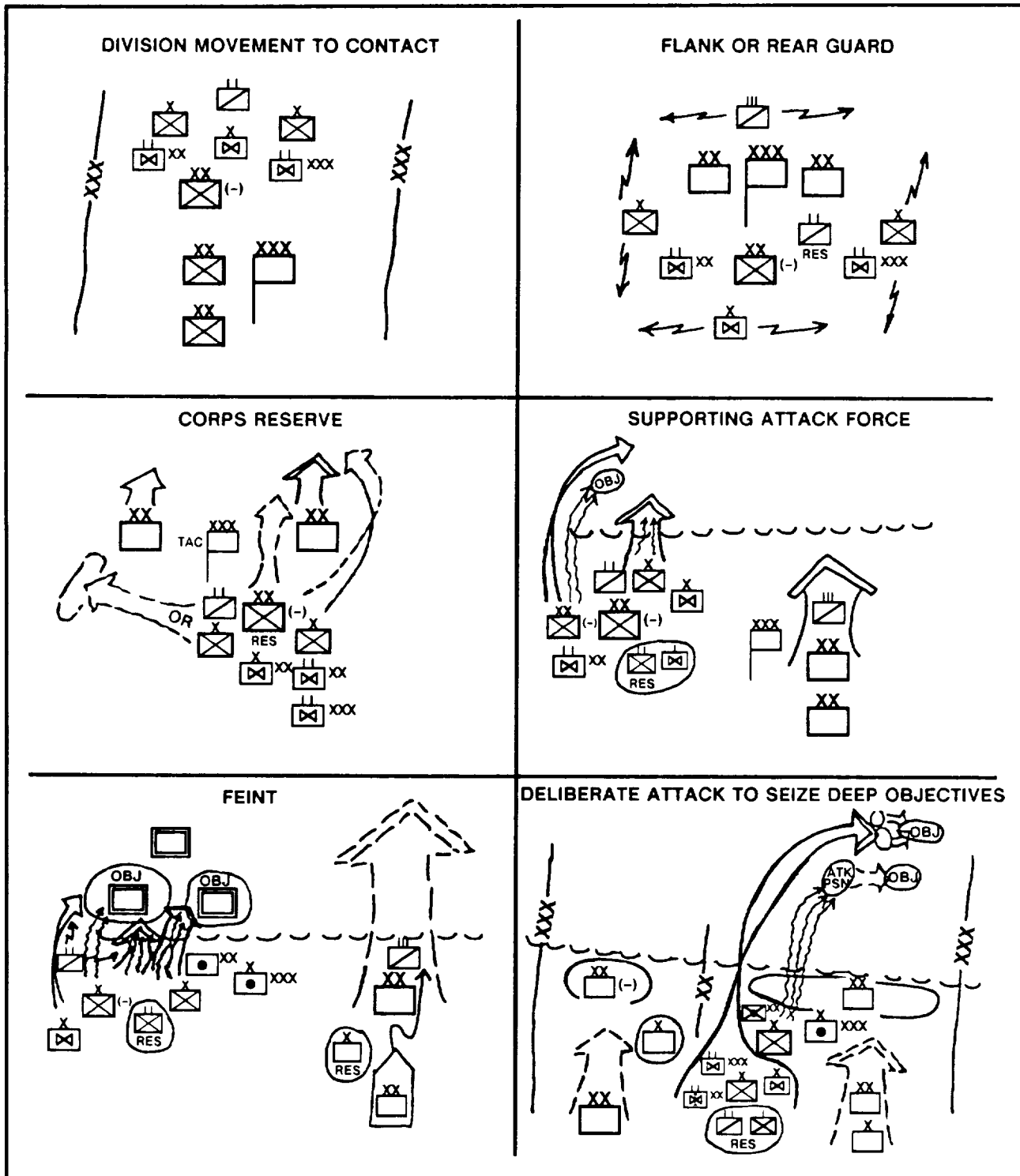

Figure 7.51. Corps offense: two. brigade division missions

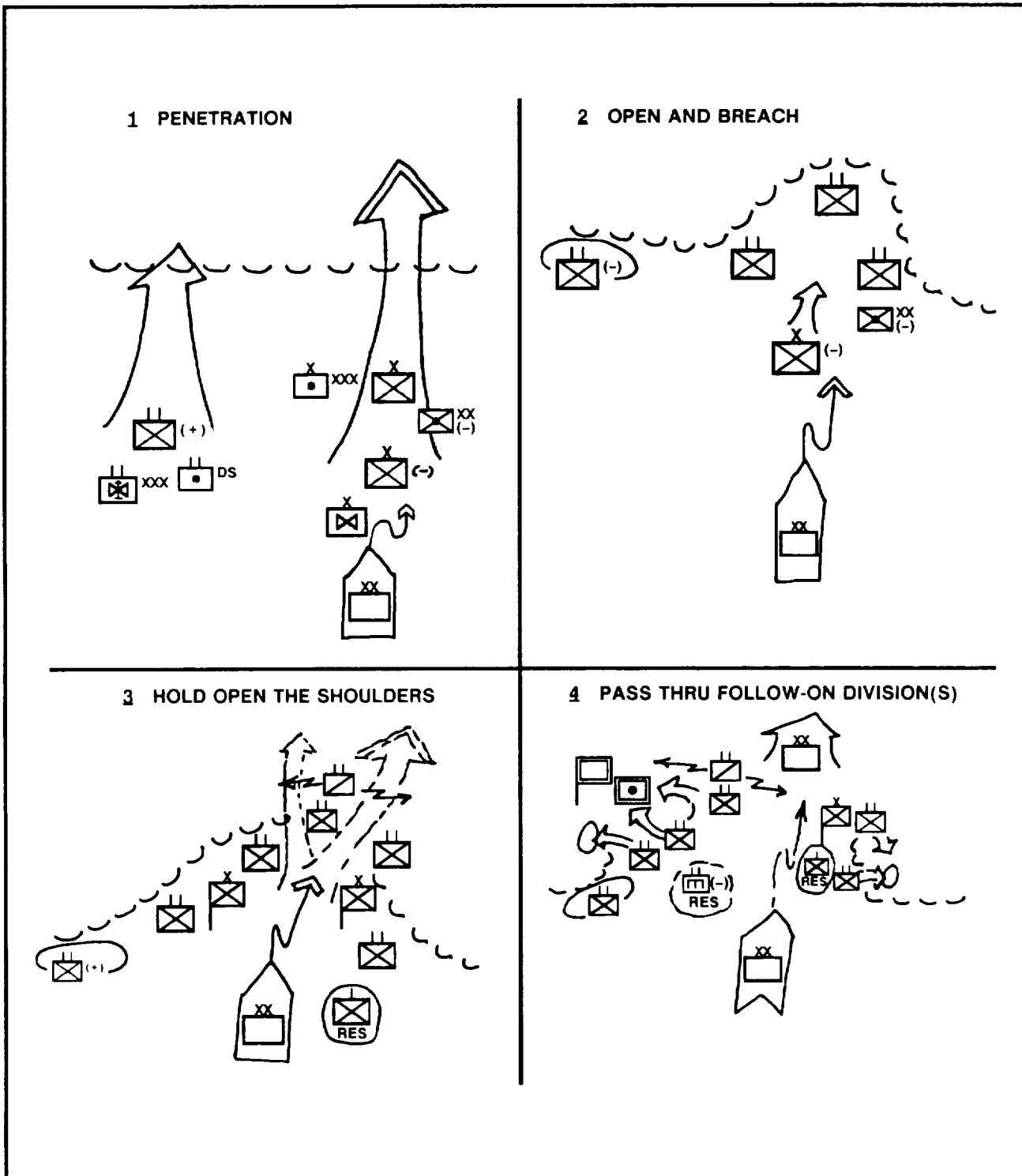

Figure 7.52. Two-brigade division: offensive techniques

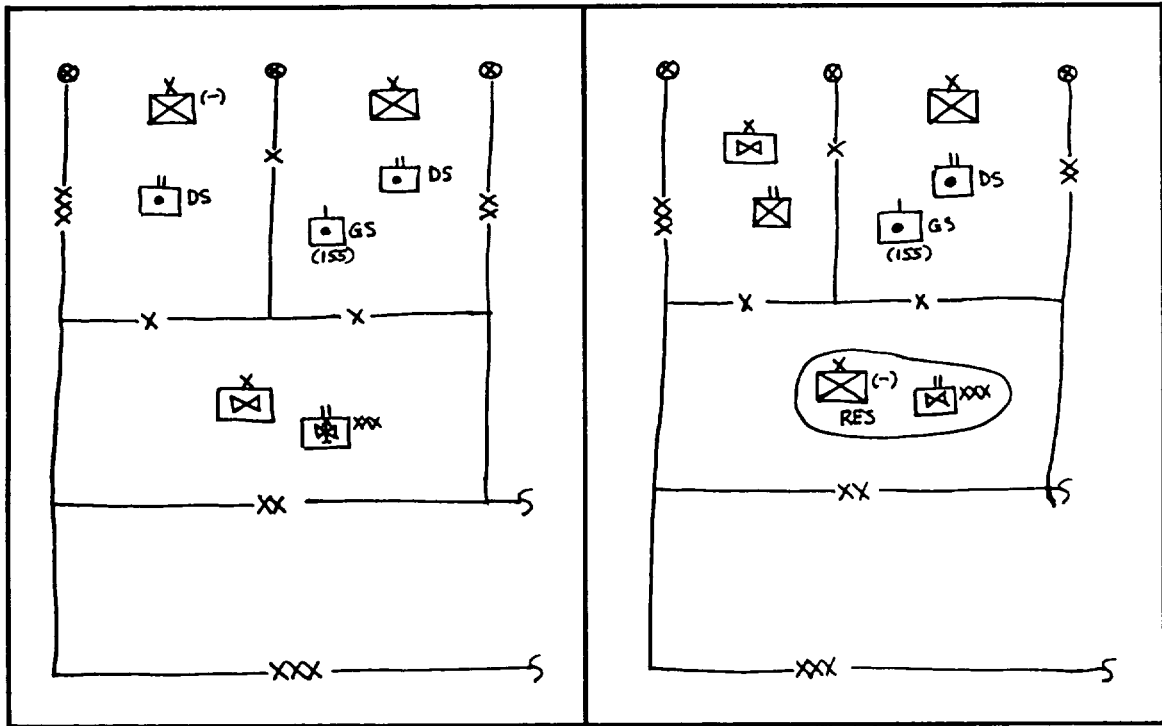

Figure 7-53. Two-brigade division: defense in sector

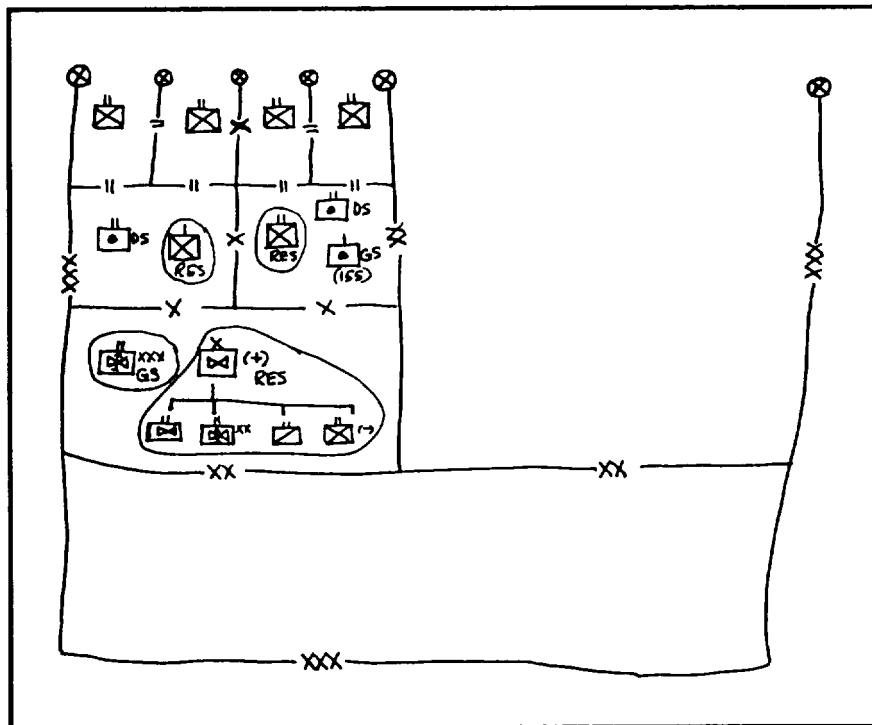

Figure 7-54. Two-brigade division: defense in sector (economy of force mission)

FIRE SUPPORT

The two-brigade division normally has only two DS field artillery battalions (one battalion DS to each infantry brigade and one 155-millimeter towed battery in the division). The division 155-millimeter towed battery is retained in GS of the division. Corps should attach at least two artillery battalions to the two-brigade division. The division should then reinforce the main effort brigade with a reinforcing corps battalion, reinforce the supporting effort brigade with its 155-millimeter battery, and retain one corps FA battalion in general support. If a corps FA brigade supports the division, each brigade receives one reinforcing battalion. The divisional 155-millimeter FA battery is attached to the corps battalion supporting the main effort. The FA brigade (-) is then retained in GS to the division. If the division receives a FA brigade (-), the DIVARTY commander recommends task organization to the division commander who approves the plan.

MOBILITY AND SURVIVABILITY

The division's three combat engineer companies provide direct support to each ground maneuver brigade. Corps should provide one OPCON corps wheeled engineer battalion with one CSE company attached and delegates authority to subassign missions. These corps engineers provide GS engineer mission support and weight the main effort with one additional corps company. The reserve is given one corps engineer platoon.

AIR DEFENSE ARTILLERY

The division ADA battalion will probably be short of FAAD systems. With a smaller division

AO and one less brigade, there may be little decrement in ADA coverage and support. However, the division may assume more risk to achieve weapons systems mutual support and weight the main effort or priority. This is not a problem when the USAF has achieved air superiority. If not, the corps must provide ADA assets to protect the division and brigade rear area as well as corps support units.

INTELLIGENCE

Intelligence assets in the two-brigade division are used the same as for a three-brigade division. Organic assets are appropriate for all missions. Interface with corps and brigades is unchanged. The two-brigade division's military intelligence battalion is employed in the same manner as a full-strength division's MI battalion. The MI battalion is at full strength unless one MI company team was task-organized to the missing brigade. The corps must provide synchronized situation intelligence development since the light division's organic assets are not as robust as an armored division's MI battalion.

COMMAND AND CONTROL

The two-brigade division's C² can fight up to five maneuver brigades. There is no direct impact on the brigade division's command and control. Commanders acknowledge the lack of a triad of subordinate maneuver C² headquarters for doctrinal tasks like main, supporting, reserve, or follow and support with other elements for security and TCF operations.

COMBAT SERVICE SUPPORT

Since DISCOM has a MSB and a FSB for each ground maneuver brigade, the level of support provided division forces remains the same.

ENVIRONMENTAL CONSIDERATIONS

This chapter discusses military operations in a variety of environments. They are military operations on urban territory (MOUT), and amphibious, cold weather, and jungle operations. River crossing operations are also discussed.

MILITARY OPERATIONS ON URBAN TERRAIN

The tremendous growth of urban areas worldwide has reduced the amount of open, maneuverable terrain available to attacking or defending forces. Many urban areas have grown together to form giant urban obstacles extending for many kilometers. These areas are generally located on or near traditional movement corridors in regions rich in natural or industrial resources. They play an important role in the economic and political life of many countries. Consequently, there are many areas of the world where attack or defense of a city maybe required.

Division commanders and staffs must understand the problems and complexities of MOUT. Doctrine applicable to the open battlefield is equally applicable to the urban battlefield. The decision-making methodology used to develop and war-game courses of action remains the same. Only the factors of METT-T change. Commanders and staffs must know and understand the unique challenges of the urban battlefield. The urban battlefield is characterized by isolation. Because of this isolation, the urban battle requires psychologically strong leaders with positive attitudes. However, the MOUT battle is the type of fighting at which properly supported infantry units excel. FMs 90-10 and 90-10-1, the current doctrinal references for MOUT, are written for battalion and lower levels. This section provides division-level commanders and staffs a summary of MOUT tactics, techniques, and procedures.

Role of the Infantry Division

The division can expect to conduct both offensive and defensive operations in urban areas. With proper training, equipment, force protection, and leadership, the infantry division can effectively defend against armored forces. In conjunction with armored forces, the division can

also conduct offensive operations against a combination of armored and light forces. The division may defend urban areas to—

- Control avenues of approach.
- Act as a combat multiplier by freeing more mobile armored forces to act as a reserve force as part of a corps or Army plan.
- Retain key transportation or economic centers.
- Protect or hide the force.
- Deny strategic or political objectives to the enemy.

As commanders and staffs conduct the mission analysis for MOUT, they must consider—

- Ž Different IPB requirements.
- SpecialC² requirements.
- Ž Unique task organization requirements.
- Ž Fire support capabilities and limitations.
- Weapons effectiveness.
- Ž Special considerations for health service and logistics support.
- Special equipment for urban operations.
- Control measures.

A discussion of each of these considerations follows.

Intelligence Preparation of the Battlefield

The IPB process for the urban battlefield follows standard doctrinal methodology. However, the nature of urban warfare requires additional information not normally generated in the IPB process. This includes—

- Ž Information on underground passages, such as sewers, subways, heating tunnels, and water and

electrical conduits which might be used by enemy or friendly forces for intracity movement.

- Information on water supplies and electrical power generation and distribution systems.

City maps and aerial photographs denoting building heights, overhead obstacles, bridges (and their locations and capacities), hospitals, and other special purpose buildings.

- A detailed building and bridge analysis, and information on building survivability and structural integrity.

- Grid or area shutoffs for power, water, gas, and other utilities,

- Information on factories and other types of industry which might impact operations, including refineries, rail yards, heavy equipment suppliers, industrial complexes, and medical facilities. (The G2 must conduct a careful analysis to determine if use of these facilities will assist or hinder operations.)

- Information on communications systems which might aid C² or the control of which might deny a hostile populace or enemy the ability to rapidly disseminate information. (These include telephone systems, radio and television transmitters, and microwave and satellite relay facilities.)

- Information on local civil authorities, political leaders, and the population. Planning for refugee problems and evacuation is critical to both offensive and defensive operations. A detailed civil affairs action plan is essential.

Command and Control

Urban combat is one of the most difficult missions infantry forces may be given. Terrain isolation is its dominant characteristic. Centralized planning and decentralized execution of MOUT is critical. Command and control of urban operations is exacerbated by terrain isolation and difficulties in communicating by tactical radio. Planning for C² must include the use of all communications systems. This includes existing telecommunications systems and TACSAT radios to link division, brigades, and battalions; FM radios; and tactical wire. The use of other devices, such as RPs, sensor strings, or remote video links, may

provide the commander real-time intelligence and can also be used to call for and adjust fires.

Task Organization for Combat

In developing effective task organizations for MOUT, commanders and staffs must recognize the unique challenges of urban warfare. Conventional task organizations may not be effective. For example, due to difficulties encountered in population and refugee control within an occupied city, additional CA support may be required. These assets may have to be provided down to brigade or lower levels. A defending division, augmented with armored forces, may opt to use them as a mobile counterattack force within a city or as part of a blocking force on a major avenue of approach. They may also be assigned a mission outside of the city to interdict the attacker's LOCs. Combat support assets, such as engineers and MI assets, may also receive nonstandard missions.

Fire Support Capabilities and Limitation

Urban terrain increases the difficulty of FS planning and execution. Man-made structures can be obstacles to effective artillery fire support, masking effective fire (even when high-angle fire is used). Positioning of DS artillery may be limited to large parks and athletic fields and may require positioning outside of a city to provide massed fires inside or on avenues of approach to the front. Batteries may have to be in nonstandard firing configurations to fit urban terrain. They may also have to operate in a direct fire mode in the offense to reduce enemy strongpoints. Subordinate maneuver units may have to rely on organic mortars for much of their indirect fire support. In both the defense and offense, the division should use a standard building marking system to assist in calling for and adjusting fire support by aircraft. In the defense, this system may actually include marking building tops. Building locations should be pinpointed using GPS to facilitate precision fire support. Additionally, there may be more RFAs, such as areas near hospitals, churches, and shrines. Information on these areas must be disseminated to the lowest levels.

Weapon Systems Effectiveness

Leaders must give special consideration at brigade and battalion level to the positioning and

use of organic weapon systems. The restrictive nature of city streets may make it impossible to position TOW and Dragon antitank systems so as to achieve the 65-meter minimum arming distance and still place effective fire on enemy armored vehicles. When fired at defensive positions in buildings, the warhead in these and other antitank missiles makes them less effective than 105-millimeter howitzers or 90-millimeter recoilless rifles (available from supporting engineer units). Time and proximity fuzes enhance the effectiveness of artillery fired at the enemy on rooftops and behind barricades. If 155-millimeter or 8-inch self-propelled howitzers are available to the division in the offense, they are effective direct-fire weapons, particularly against bunkers and entry points.

Tanks and BFVs can be extremely effective in the city in supporting both offensive and defensive operations. Tank main guns generally do not make good entry-point holes in buildings, but can prove effective when fired at point targets. High-explosive ammunition should be used in most cases. Tanks can destroy steeples, tall chimneys, and other structures containing enemy artillery observers. The tank's greatest value may be its mobile machine gun support to maneuvering infantry. With two 7.62-millimeter and one .50 caliber machine guns, two tanks have the mobile machine gun firepower of an infantry company.

The division can use attack helicopters at night to detect and eliminate the enemy in strongpoints. If terrain permits, they can also provide precise fire support. Like armored forces, attack helicopters can play a decisive role in interdicting attacking enemy forces and their LOCs.

When the division defends strongpoints, antitank mines will be more difficult to emplace and conceal in urban areas; consequently, their effectiveness will be degraded. The use of antipersonnel mines inside buildings may be more effective. More information on weapons effectiveness is found in FMs 90-10 and 90-10-1.

Health Service and Logistics Support

The number of casualties will be high in the city battle and the difficulty of evacuation greater. Aerial evacuation will be extremely

difficult and even impossible in some areas. To deal with these challenges, trauma treatment centers, with doctors, may need to be positioned well forward in the offense, or established throughout the city in the defense. Medical care and evacuation are critical to maintain the morale and confidence of soldiers. Combat lifesavers will need to be supplemented with additional medical supplies because casualties will be higher and evacuation times likely increased. Medical evacuation routes and casualty collection points may be more difficult to coordinate due to obstacle belts and battle-induced rubble.

Logistics support is greatly affected by the city battle. Logistics must support changes in demand which occur during the attack or defense of a city. The division will experience major increases in demand for small arms, grenades, 40-millimeter projectiles, mines, mortar ammunition, light antitank weapons, and demolition equipment. Due to changes in consumption rates, units may not properly forecast their ammunition requirements. As a result, resupply must be pushed, not pulled. Where possible, supplies and ammunition must be stockpiled in the defense. Conversely, the division must make every effort to interdict an attacker's LOC to slow and defeat his attack. This may require positioning small units outside a city prior to an attack. Large numbers of displaced persons can also adversely affect the division supply system.

Special Equipment Requirement

A division fighting in a city may need special equipment. At battalion level, this may be shotguns, body armor, additional sniper weapons, and more concussion, smoke, and fragmentary grenades. A description of special equipment can be found in FMs 90-10 and 90-10-1. At the division level, additional communications assets may be required. Infantry divisions do not have sufficient wire and telephones to effectively "wire-in" a city defense. Since such assets may not be available, the division may require additional TACSAT radios to improve communications.

Control Measures

Combat in urban areas requires the same control measures as operations in other terrain. However, in the urban fight, some control measures

will be easier to identify while others may be more difficult. These include—

- Frontages and zones of action.
- Boundaries.
- Checkpoints and contact points.
- Phase lines.

Ž Objectives.

Frontages and Zones of Action. In the offense, brigades are normally assigned relatively narrow zones of action, based on enemy strength, size of buildings, and level of expected resistance. An attacking brigade task force could be assigned a frontage of from 6 to 12 city blocks. Frontages and zones of action influence formations.

However, in the urban battle, commanders should maintain a significant reserve well forward. The reserve can add momentum to the attack, exploit success, repel counterattacks, and protect flanks and the rear from enemy action.

Boundaries. Boundaries should be easily identifiable. No strict rules apply to boundaries, except one unit should control approaches. In dense urban areas, boundaries may be placed on one side of a street to give a defending unit responsibility while buildings on the opposite side are occupied by another unit. Boundaries may also be placed to allow one unit to include both sides of a street. Boundaries should never divide a major avenue of approach. Assignment of boundaries must be the result of careful terrain analysis.

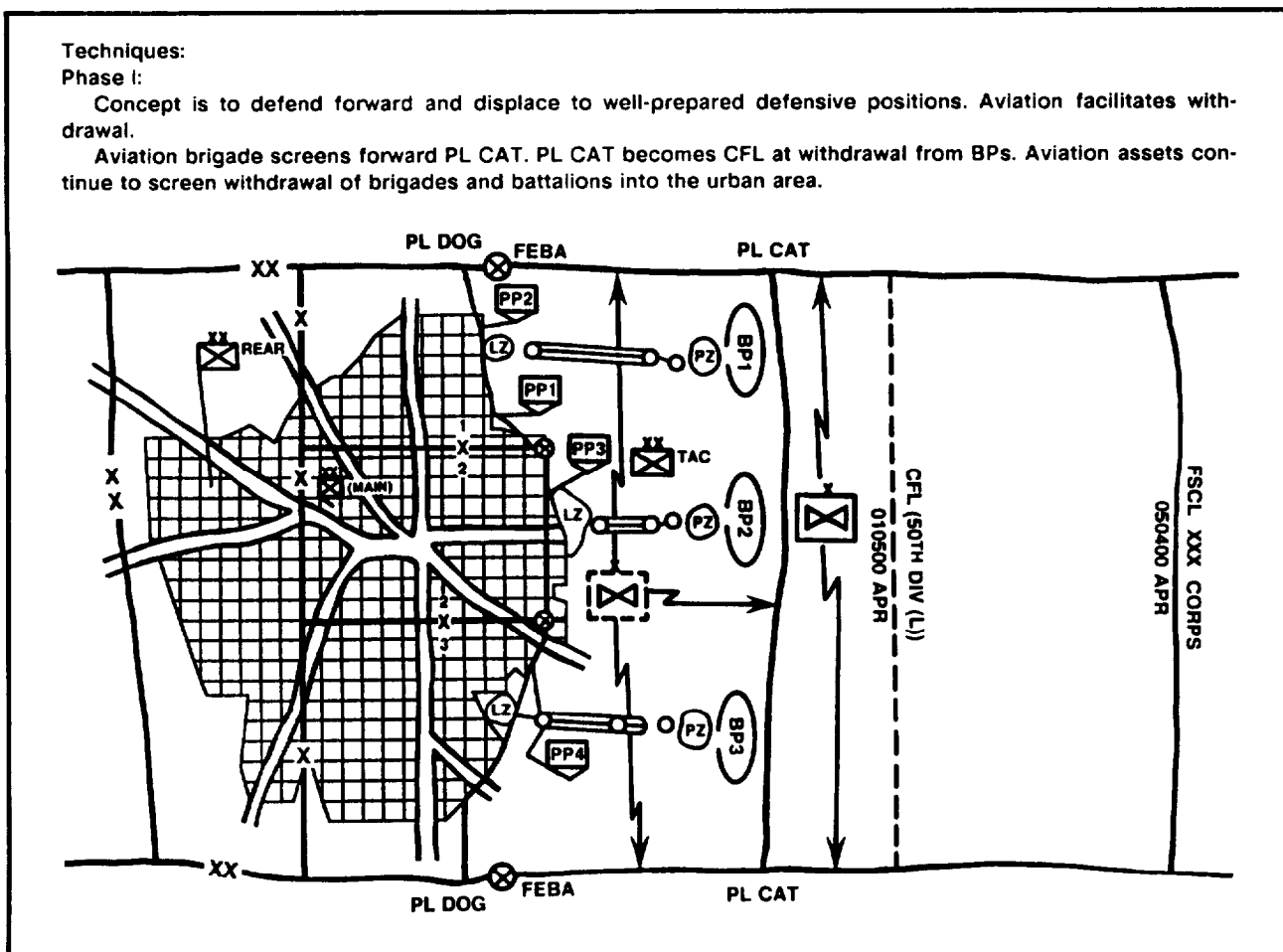

Figure 8-1. Example defensive MOUT operation: phase I

Checkpoint and Contact Points. Street corners, buildings, railway crossings, bridges, and other easily identifiable features can be assigned as checkpoints or contact points. As in any operation, these are critical, specific points where the commander desires units to make physical contact.

Phase Lines. Phase lines increase control in both the offense and defense. In the offense, they assist in regulating the advance of attacking forces and synchronizing the battle. In the defense, they assist in reporting enemy penetrations and may be used to trigger command decisions. Streets, rivers, and trolley and railroad lines make easily recognizable phase lines.

Objectives. In the urban fight, objectives can take on several characteristics. They can be terrain, such as a principal building, or a specific area, such as a petroleum tank farm. They can also be several buildings located around a major intersection. If the commander's intent is to clear in zone up to a specific point, a limit of advance may be more appropriate than an objective.

Defensive Operations

Built-up areas present obstacles to an attacking force while providing the defender an advantage and some protection. A small, well-prepared force in an urban defense can defeat or hold off a much larger attacking force. Strongly constructed cities give the defender a decided advantage. Each building or group of buildings is a potential strongpoint. With additional construction and the use of barricades, mines, and booby traps, an urban area can become a veritable fortress. Under some conditions, elements of the division may hold built-up areas while the remainder of the division defends from adjacent restrictive terrain.

The following are techniques and guidelines for defensive MOUT operations:

• *Establish* defenses in depth in built-up areas. The defense must start far forward and include approaches to the urban area.

- *Integrate* adjacent terrain into the defense.

• *Use* security forces operating in depth to counter enemy ground reconnaissance and infiltration.

- *Use* restrictive missions and detailed control measures to facilitate decentralized execution.

- *Employ* the combined arms team to maximize individual unit capabilities.

- *Maintain* a strong, mobile reserve to counter-attack and block penetrations.

Figures 8-1 and 8-2 are examples of defensive MOUT operations.

Offensive Operations

A detailed study of an urban area and enemy dispositions in and around it forms the basis for planning the attack. As in any attack, planning must provide for both maneuver and fire support. Attacking forces may be an infantry-heavy assault force and a tank-heavy enveloping force. Coordinated fires support both forces. The enveloping force—

- Prevents the enemy's escape.
- Prevents reinforcements from entering the city.
- Provides direct FS for the direct assault force.
- Protects the assault force from counterattack.

The assault force clears the city of enemy resistance and links up with the enveloping force. The attacker has the advantage of maneuver to isolate an urban area. Then, he can either press the attack or contain the defender and perhaps force him to capitulate without a direct attack. The attacker selects his best point of entry and can attack from any direction. He can choose to bypass strongly defended buildings and contain or isolate the defenders.

The following are proven techniques and guidelines for conducting offensive MOUT operations:

- *Attack* a built-up area only as the last resort, and only when major advantage accrues through its seizure or control.

- *Know* the characteristics of urbanized terrain and advantages and disadvantages it offers to either attacker or defender.

- *Attack* where the enemy is weak—hit his flanks and rear simultaneously.

- *Require* detailed planning by subordinate commanders to enhance decentralized execution and minimize C² problems during an attack.

Phase II:

Phase II is an enlargement of the urban area.

Division assigns alphanumeric designations to each block. Brigade is responsible for numbering all buildings, dwellings, houses and structures. No fire areas (NFAs), hospitals and cultural and religious areas, are preserved.

Once inside the urban area, far sides of blocks (enemy side of the street) are the CFL during withdrawal. Brigade develops CFL, division consolidates.

Boundary shift for 1st brigade is behind PL BIRD to brigade rear boundary.

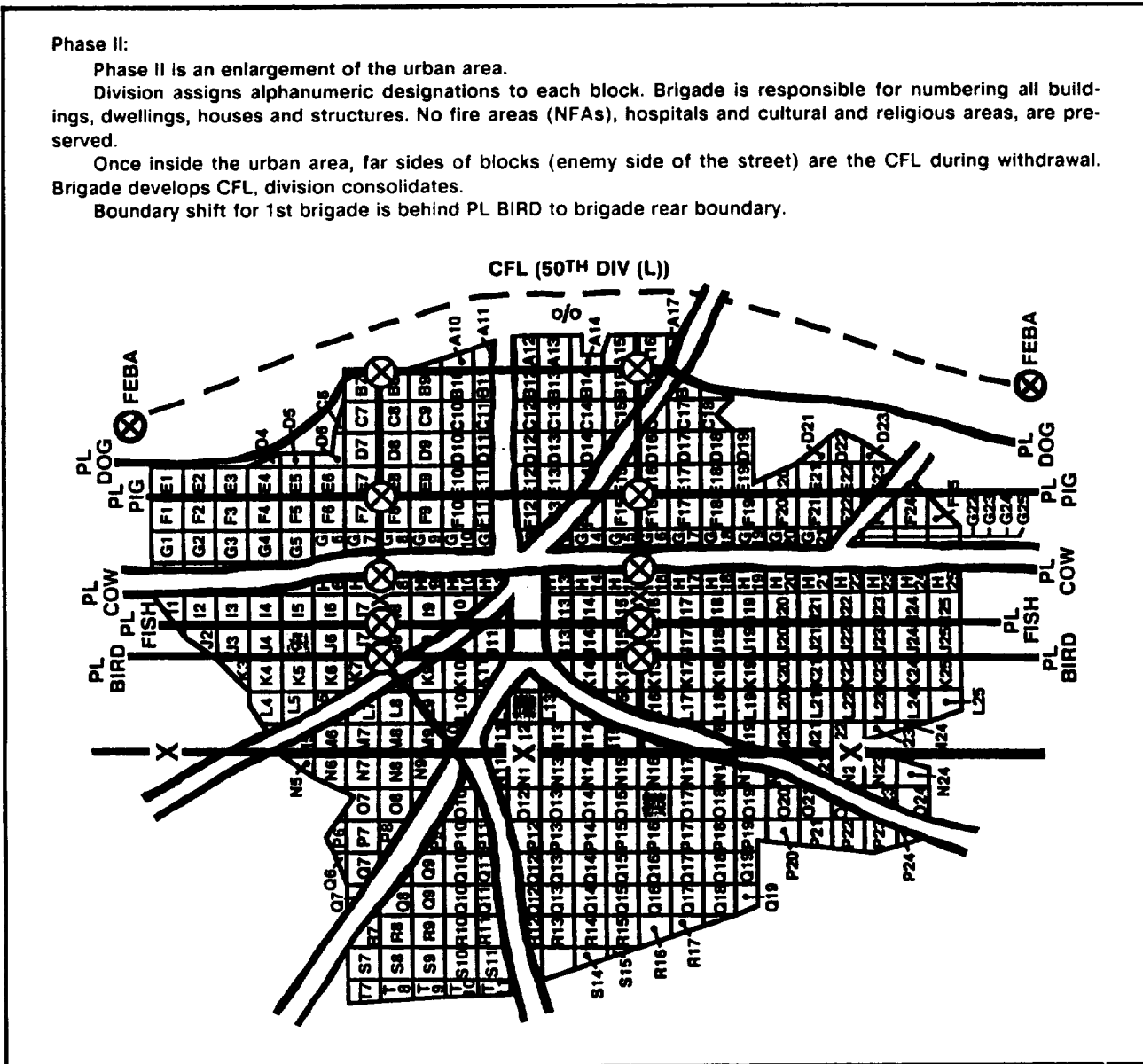

Figure 8-2. Example defensive MOUT operation: phase II

- *Employ* combined arms team to maximize capabilities and minimize vulnerabilities.
 - *Dissipate* an enemy's strength by causing him to react to demonstrations, feints, or ruses.
 - *Maneuver over* approaches to a built-up area with smoke protection and overmatching fires.
- Ž *Reduce* strongpoints with fires where possible, then keep moving, and secure them with follow-on forces.

- Ž *Cut* lines of communications and defeat the enemy through isolation.
- Ž *Attack* at night to gain surprise and maximize the night technology advantage of US forces.
- Ž *Keep* the attack continuous until defenses have been splintered once momentum has been gained.

Figures 8-3, 8-4, and 8-5 are examples of offensive MOUT operations.

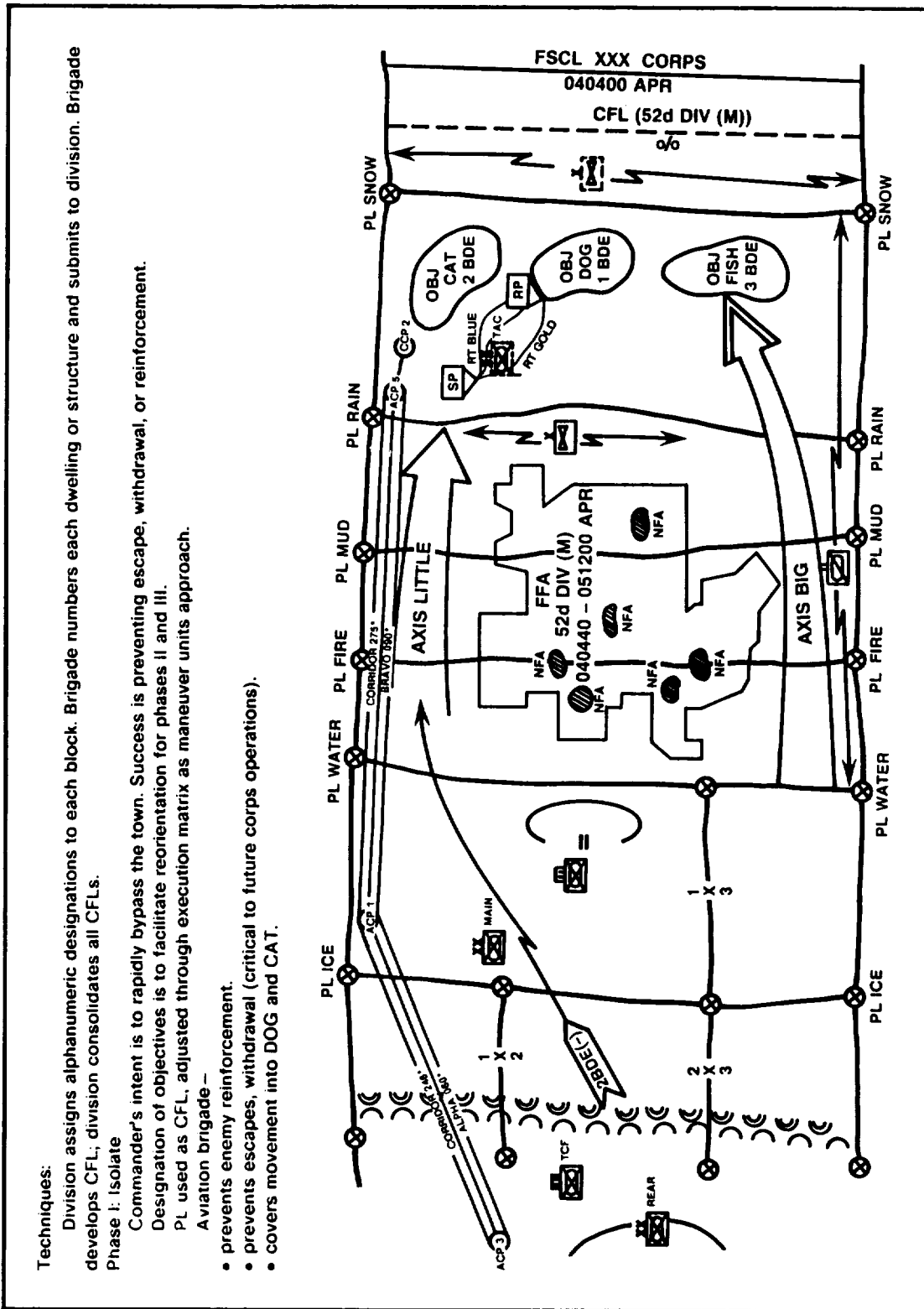

Figure 8-3. Example offensive MOUT operation: phase I

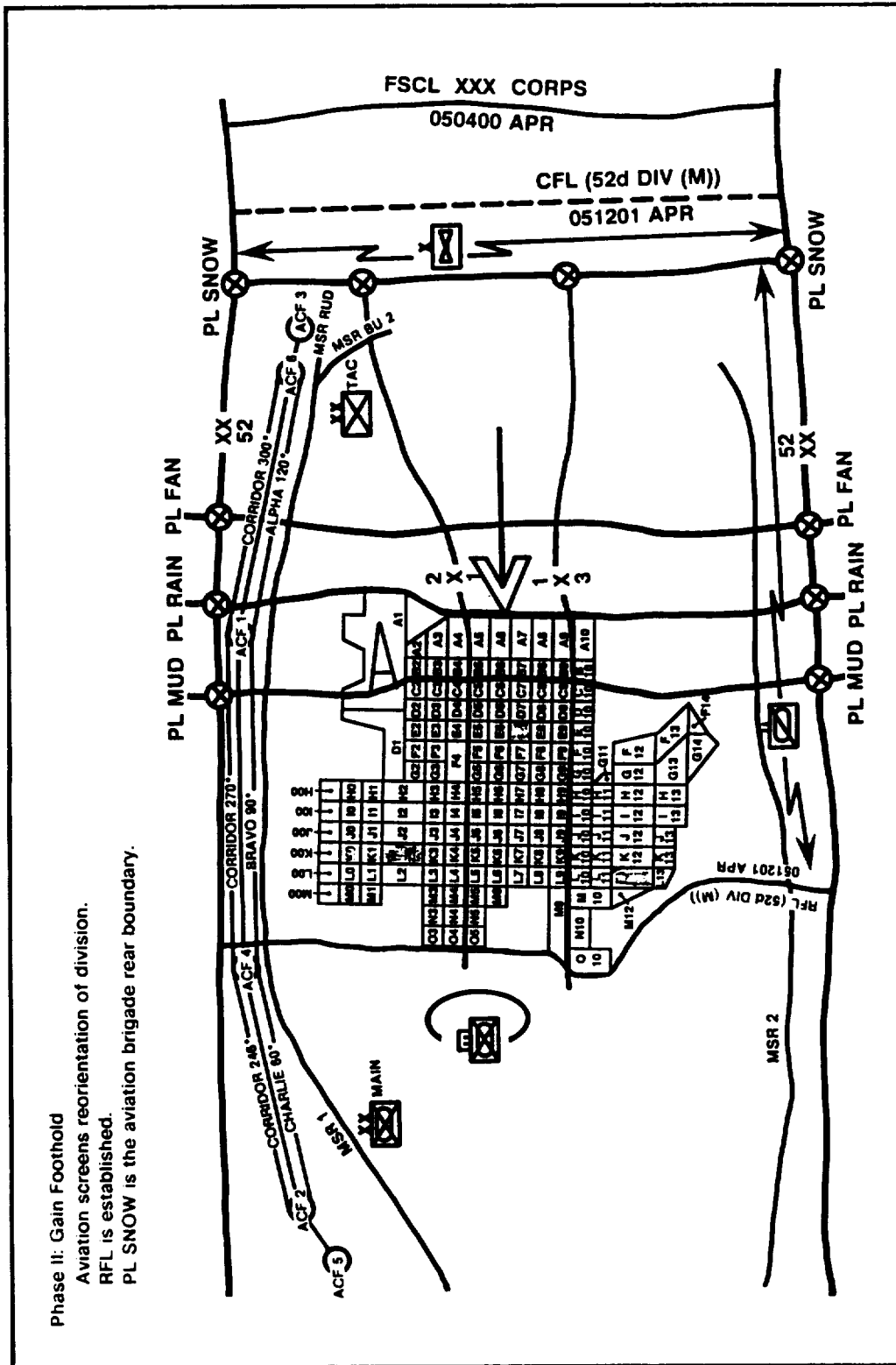

Figure 8-4. Example offensive MOUT operation: phase II

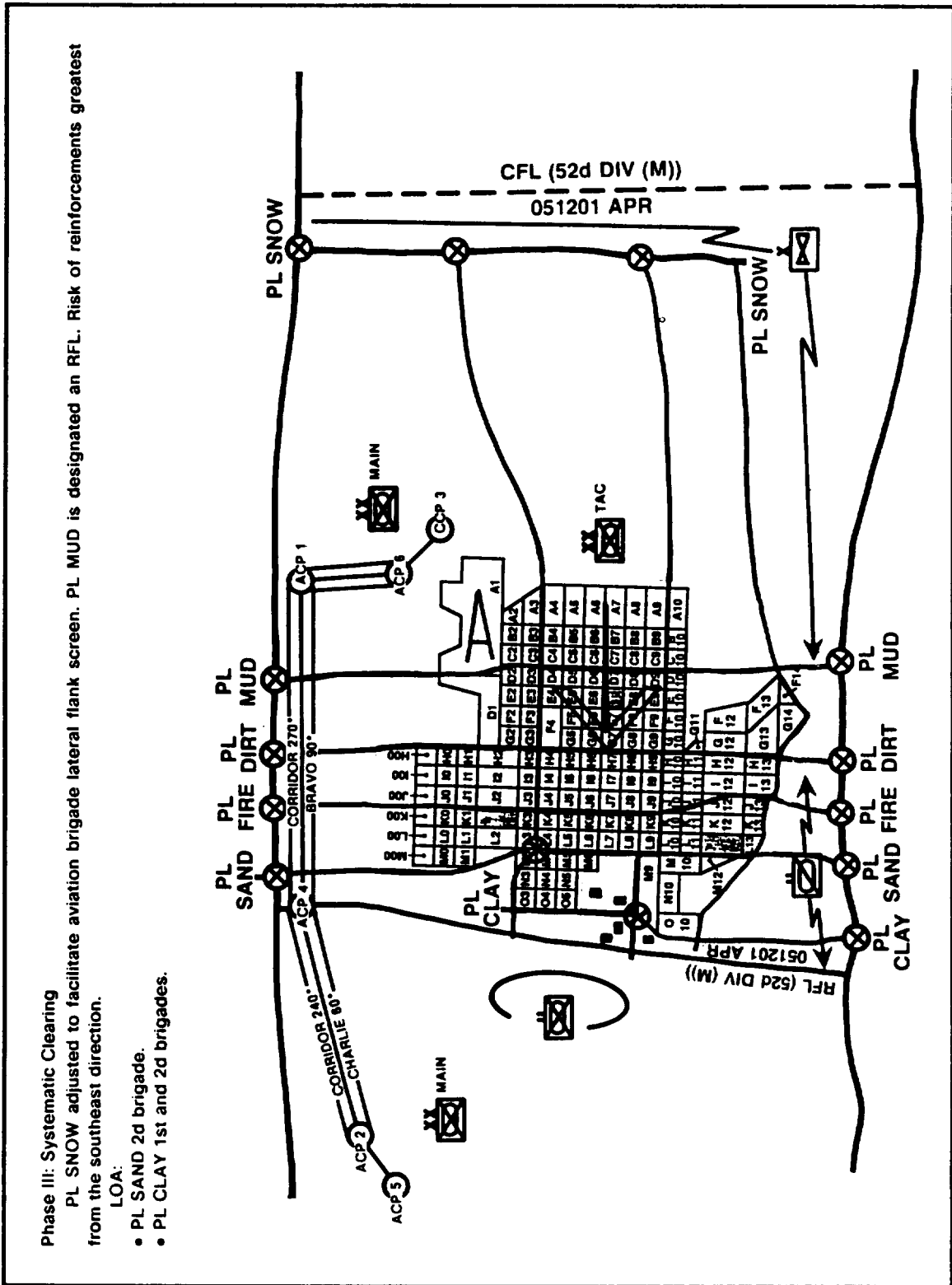

Figure 8-5. Example MOUT operation: phase III

Attacks in MOUT normally have three phases. *Phase I* is isolation of the city and seizure of terrain features dominating approaches. The division secures positions outside the built-up area from which to support entrance into the city itself. The tactics and techniques for this phase of the operation are similar to those of attacks against other well-organized enemy positions.

In *phase II*, the division advances to the edge of the built-up area and gains a foothold, while eliminating the defender's observation and direct fires on approaches into the area. From the foothold area, the attacking unit penetrates on a narrow front with tanks and infantry leading where possible. Supporting fires on the entry point focus on this frontage and on preventing attacks from the flanks. Assaulting forces can expect to encounter barricades, antitank obstacles, mines, boobytraps, and antitank fire. The probability of success increases if the assault is launched from an unexpected direction during periods of limited visibility, or under cover of smoke.

Phase III varies from a systematic, block-by-block, house-to-house reduction of the built-up area to a rapid advance with clearance of only critical areas and buildings. Phase III begins without pause after the completion of phase II. Clearance and seizure techniques depend on METT-T.

When the built-up area is large and heavily fortified, and the mission requires a methodical house-by-house, block-by-block clearance operation, the division should divide the area into brigade zones of responsibility. Each subordinate unit must clear its zone completely, leaving no enemy to its rear.

There may be occasions, such as the US intervention in Panama in 1989, where light forces deploy in support of national objectives to eliminate a hostile military or oppressive paramilitary force. Under such circumstances, a large percentage of the population may actually be sympathetic to the policy and objectives of the United States. Restrictive ROE normally characterize this type of action, which may be part of a NEO. In such cases, a graduated response may be warranted. This may include a demonstration using the precision fires of AC-130s, AH-64s, or field artillery in proximity to, but not actually on,

hostile forces in an attempt to convince them to capitulate.

Operation JUST CAUSE provides several excellent examples in which a graduated response resulted in the surrender of enemy forces. In one instance, US Army Rangers used the precision fire of an AC-130 to convince a Panamanian garrison to surrender. The garrison commander was directed to call other Panamanian units and report what he had seen. The result was the surrender of several other units without a direct confrontation. In addition to preserving life on both sides, a graduated response may also assist in building or retaining the sympathy of a local population by limiting physical damage and loss of life. A graduated response maximizes economy of force.

AMPHIBIOUS OPERATIONS

Infantry divisions participate in amphibious operations as part of the Army component of a joint amphibious task force. Joint Publication 3.02 series and FM 31-12 set forth the fundamental principles, doctrine, and procedures for the Army component of a joint amphibious task force, including preparatory training.

An amphibious operation is an attack on a hostile shore launched from the sea by naval and landing forces. It includes the following phases—planning, embarkation, rehearsal, movement, and assault.

The Army landing force is the Army component of the joint task force. The composition and size of the Army component varies with the type of amphibious operation, the force's mission, and the environment. The Army landing force is made up of basic tactical organizations. They vary in size from the lowest echelon capable of semi-independent operations to a field army. The force may include elements of a division, a complete division, or several divisions of the same or different types. Assault divisions are those divisions of the landing force that execute assault landings.

Armored, infantry, light infantry, or mechanized divisions are normally surface assault divisions. However, infantry divisions are best suited for use as surface assault divisions because of their suitability for movement in transport ships and ship-to-shore assault craft and aircraft. They

also require less logistics support initially. The large numbers of heavy vehicles in mechanized and armored divisions require more landing ships for movement and landing. They have a continuing requirement for large amounts of logistics support.

Mechanized and armored divisions are well suited for landing over secured beaches. They can advance rapidly inland in exploitation or pursuit. Airborne and air assault divisions are not normally surface assault forces in amphibious operations due to their unique, long-range deployment capabilities. In amphibious operations, C³ is vital. All components of the force prepare and coordinate detailed plans.

Amphibious Task Force Objective, Area, and Mission

The amphibious objective area is the AOR the establishing authority assigns to the amphibious task force commander. It includes land, sea, and air space for operations.

The division's mission usually includes an area or areas it must seize within the objective area. The commander and component commanders select general courses of action for those objectives.

The mission for the Army component is to accomplish the larger task force mission. However, when the purpose is invasion or tactical maneuver, the mission must also include preparations for the land campaign after the amphibious operation places the force on the hostile shore. Commanders must consider the need for the rapid landing of follow-up units to exploit beyond the beachhead.

Basic Considerations for Operations Ashore

The Army landing force commander translates the assigned mission of the Army force into specific objectives ashore. The objectives influence the size and composition of the force and the scheme of maneuver. The scheme of maneuver, fire support, and phasing of the operation make up the landing force commander's concept of operations. Before deciding on a scheme of maneuver, he must consider conditions in the

amphibious attack and their effect on force organization.

Development of Combat Power Ashore

The landing force develops combat power progressively. The force can exert only a small fraction of its total combat power initially. Small units fighting independently, supported by naval guns, missiles, and tactical aircraft, initiate the attack. Land combat power gradually increases until the entire landing force is ashore, functioning as a cohesive organization and exerting its maximum combat power. The echeloning of the landing plan should provide for the orderly development of combat power.

Rapid and aggressive action maintains the momentum of the assault. Commanders must reduce delays to the absolute minimum. Using dispersed forces in amphibious operations aggravates problems in achieving mass, C³, and combat and administrative support.

Echeloning for Landing

The rate of landing and development of combat power ashore depends on several factors. The most important are—

- Availability of shipping and landing craft, amphibious vehicles, and helicopters as ship-to-shore movement means.
- Capacity of the landing beaches and zones.
- Degree of enemy resistance to the landing.
- Extent of fire support provided the landing force.
- Terrain, weather, and sea conditions in the landing area.
- Need for balance among combat, CS, and administrative support units.
- Area available ashore for maneuver and dispersal.

These factors influence the rate of landing and, thus, the composition of the assault echelon. The number and types of available amphibious assault ships and means for ship-to-shore movement may also limit the materiel the force can land initially. The commander must include only

essential personnel, equipment, and supplies in the assault echelon.

He must also organize his force to reinforce assault units for self-sufficiency. Division planners should schedule units and supplies and equipment not needed early in the assault for later arrival in the objective area.

Forces executing landing and initial onshore operations are structured according to the commander's concept for the attack. This concept, the nature and extent of enemy defenses, and the terrain determine troops and fires to use in the assault, in support, and in reserve.

Normal control and support from the next higher echelon is initially absent. Each command echelon should be capable of independent operations until the next higher echelon is ashore and can assume responsibility for control and support. In the interest of speed, mobility, flexibility, and economy of force, attachments should be those essential to independent operations.

To support the concept of operation, the organization for landing must provide—

- Maximum shock effect at the point of landing and cumulative shock effect in the direction of the objectives.
- Depth to the assault for flexibility and a sustained buildup of combat power as the attack develops.
- Dispersion consistent with other requirements.
- Flexibility sufficient to exploit weaknesses in enemy defenses.
- Timely establishment and use of both tactical and administrative support systems ashore.
- Tactical integrity of subordinate organizations.

Reinforcement requires attaching units to subordinate organizations to achieve unity of command. Attachments are for a specified or unspecified time, until a certain event has taken place, or for the duration of the landing. A unit is under the control of the organization to which it is attached during landing. Thereafter, it reverts to the control of its parent or other organization. The headquarters making attachments for the landing designates the approximate landing time (or

sequence). The organization to which a unit is attached schedules the unit ashore. The landing force commander makes attachments for a landing when a unit must land early to prepare for subsequent operations. He may also do this if he does not want to delegate command authority to subordinate commanders. Examples of attachment to an assault division are a battery from the corps artillery brigade, or elements of a construction unit which must make early reconnaissance.

The organization for movement and landing of the force has three echelons:

- The *advance force echelon* includes elements of the landing force included in the amphibious task force advance force.
- The *assault echelon* is made up of the assault elements and reinforcing elements. The latter land on a nonscheduled basis on beaches or in landing zones already secured by landing teams. Assault shipping transports the assault echelon.

• The *follow-up echelon* consists of elements not required in the assault echelon. Assault shipping or follow-up shipping (or both) transport the follow-up echelon.

Phasing of the Attack

The commander must consider the rate of landing of tactical and support forces to phase a land offensive. Phasing which calls for exploitation out of the beachhead must be realistic. The commander must phase the assault in his concept of operations. Subordinate leaders then designate objectives and phase lines to implement the concept.

Decentralized execution characterizes the initial phase of an amphibious assault. The commander should not reduce the speed of his rapid and decentralized attacks by attempting to reestablish centralized control too quickly. On the other hand, he should not expose his forces to the danger of defeat by hesitating to reestablish this control when it is necessary.

Fire Support

A major difference between land and amphibious operations is the landing force's initial dependence on nonorganic fire support. Until FS lands on shore and is ready to carry out its

mission, the force depends on naval, missile, and aircraft fires. When organic FS is established ashore, aircraft, missiles, and naval fires revert to their normal support roles.

The dependence on nonorganic FS influences the selection of initial objectives and maneuver. Naval guns, missiles, and aircraft are ideally suited to support dispersed tactical formations. The commander can use them anywhere (within limitations imposed by the sea, weather, and the maximum range of naval guns).

Reserve

The reserve in an amphibious attack may consist of fires, maneuver elements, or a combination of both. The commander will usually withhold a portion of the initial assault force to provide security to the landing force and flexibility to the assault. This portion of the force lands when and where the commander desires to best influence the tactical situation as it develops ashore. It is, in effect, a landing force reserve.

Within the division, use of the reserve may be limited during the initial assault. Then, all assault teams deploy to achieve maximum shock effect. The division commander can influence the action ashore with reinforcing elements which land on a nonscheduled basis. While afloat, reinforcing units are also a reserve force.

Commitment of the reserve is more complex than in normal land operations. While the reserve is afloat, the nonavailability of landing craft, amphibious vehicles, or helicopters, and the time required for debarkation and movement ashore, delay its commitment. Therefore, commitment of these forces must be anticipated far enough in advance to compensate for this time.

If the reserve is afloat in landing craft or amphibious vehicles, or on a ship with helicopters standing by, the ship-to-shore movement of other elements of the landing force may be delayed for lack of suitable landing means. Landing of the reserve by surface means requires availability of a suitable landing beach.

Because of the decentralized nature of initial operations ashore, it may be difficult to coordinate the landing of the reserve with operations ashore. When there is no longer any advantage in

keeping the reserve afloat, it should land and take positions ashore. The commander should not order this until the assault force has seized sufficient area ashore to permit dispersion of the force.

Because the outcome of operations ashore may be unclear, the commander should maintain maximum flexibility of his reserve force until a specific need for its commitment arises. The reserve should be able to take over the assault mission of committed units and should have plans for this contingency. It should have adequate attachments including a shore party. Plans should provide a means for landing the reserve in an assault role.

The commander may favor retaining a higher-echelon reserve in base areas; he can transport it to the objective area in aircraft if there is a shortage of assault shipping or congestion in the objective area. The commander should plan to use fires held in reserve for contingencies, to support forces ashore, and to aid exploitation.

Beachheads and Corresponding Landing Areas

The process of choosing beachheads and landing areas begins with considering potential sites. The selection of beachheads and landing areas, and the concept of operations ashore are closely interrelated. The commander and staff must consider them concurrently.

A beachhead is an area extending inland from the water's edge which, when secured, will permit continuous landing of troops and materiel and provide maneuver space for further operations ashore. The landing force commander determines which beachheads are suitable for operations.

Each echelon of command in the landing force must establish a secure and effective beachhead. Establishment of a beachhead is a condition to achieve during the assault, not an end in itself. The final beachhead will generally conform to the landing force lodgment area (as derived from analysis of the amphibious task force mission).

The landing force commander must tentatively select beachheads for the next subordinate landing force command echelon. For example, when the landing force is a corps, the corps commander must consider possible division

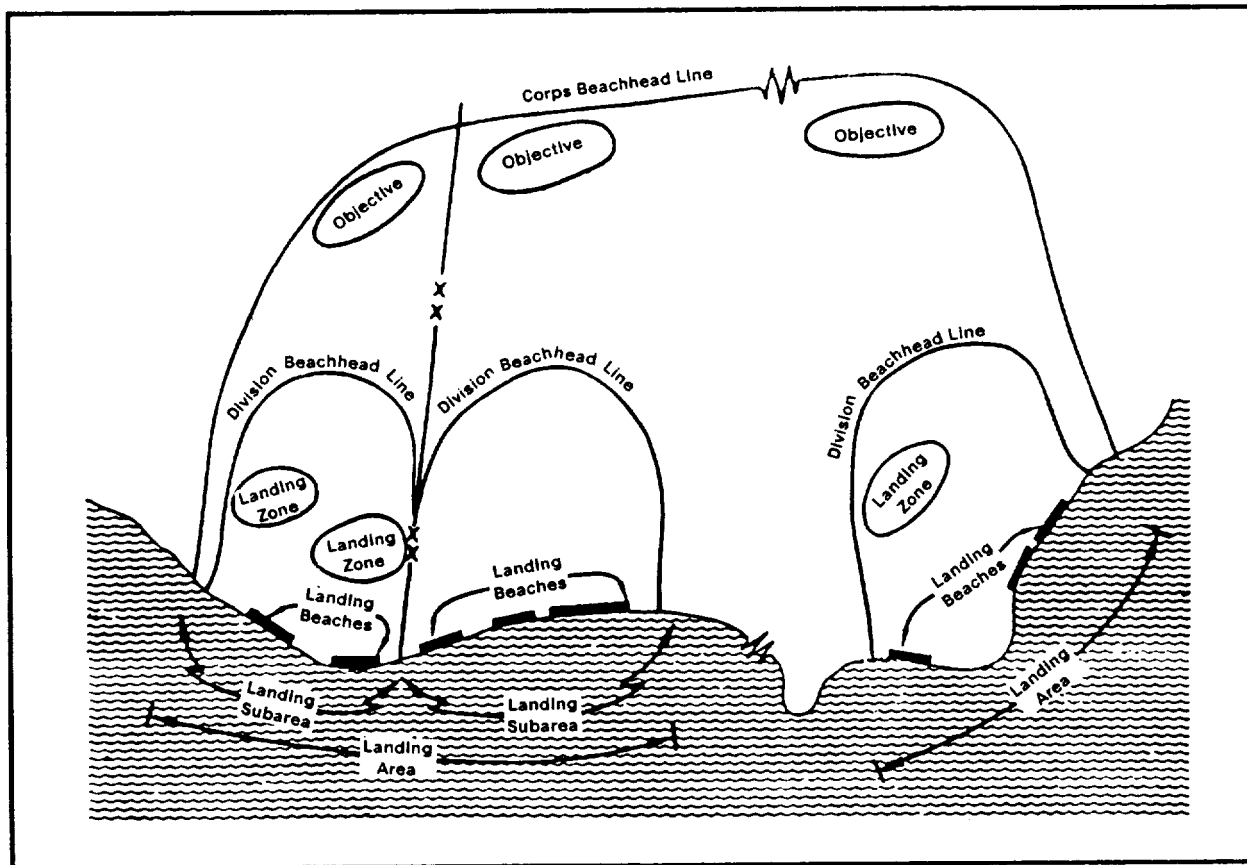

Figure 8-6. Beachheads and landing areas (schematic)

beachhead lines. Beachheads may be either separate and dispersed; or they may be zones of action defined by a boundary, within the beachhead of the next higher echelon. (See Figure 8-6.)

A landing area is that part of the objective area within which an amphibious task force conducts landing operations. It includes:

- The beach.
 - Approaches to the beach.
 - Transport and FS areas.
- Ž The air occupied by close supporting aircraft.
- The land included in the advance inland to the initial objective.

When two or more divisions execute assault landings, they use more than one landing area, or divide the shoreline within a single landing area into two or more landing subareas. After selecting

a general landing area, the landing force commander divides the usable shoreline into zones of action for subordinate echelons. He selects landing beaches within the assigned zone of action to support his scheme of maneuver ashore.

The landing areas selected must satisfy both naval and landing force requirements. Considerations are the—

Ž Ability of naval forces to support landings and subsequent operations.

Ž Degree of shelter from unfavorable sea and weather conditions.

- Suitability of the beach for the assault ships and craft employed.

- Extent of mineable waters and conditions affecting the ability of the enemy to defeat mine countermeasures.

- Capabilities and dispositions of the enemy.

- Feasibility of improving unloading facilities, including early seizure and rehabilitation of the port.

Ž Suitability of the landing area for ease of tactical maneuver ashore to attain rapidly the final objective.

Ž Suitability of landing sites.

- Nature of terrain inland from the beaches.

Ž Adequacy and accessibility of routes away from the beaches.

- Suitability of the area for administrative support activities.

The naval component commander delineates the sea areas and air space required to establish each beachhead the landing force commander has selected. The amphibious task force commander designates the combinations of sea and beachhead areas as possible landing areas. He also indicates their relative desirability.

In developing his concept of operations ashore, the landing force commander selects primary and alternate landing areas from among those the amphibious task force commander has designated. He maintains continuous liaison with interested commands regarding constraints on operations. He selects those landing areas which will best aid in accomplishing the landing force mission. He then coordinates his final selections with other component commanders and the amphibious task force commander. He ensures their concurrence with the selected landing areas—given the abilities of sea and air forces to support these operations.

Concept of Operations Ashore

After determining suitable landing areas, the landing force commander outlines his primary and alternate concepts of operations ashore. The offensive ashore to seize objectives on the ground is the end for which the amphibious assault is the means.

Naval and air components must be able to support the concept of operations. This is a prerequisite to detailed planning. The landing force commander's concept of operations must be detailed enough to reflect—

Ž Basic assumptions.

Ž Designated objectives.

Ž General scheme of maneuver.

Ž Formation for landing in task organization.

Ž Beachhead lines.

Ž Ship-to-shore movement means.

Ž Fire support.

- Plans for any subsidiary operations.

When other component commanders concur with the landing force commander's concept of operations, he issues planning guidance to his subordinates.

Armored-Light Considerations

Armored divisions normally are not used in the assault phase of an amphibious assault. However, in certain situations, armored units (brigade sized or smaller) are landed with infantry to seize key terrain in the landing area.

In large-scale amphibious operations, infantry may secure a beachhead followed by an armored division or a brigade to increase firepower, mobility, and shock effect. Cavalry and air cavalry units may undertake reconnaissance and security missions before, during, or after the assault landing. Ground cavalry units usually conduct operations during and after the landings. They maintain contact between widely separated landing forces or may seize lightly defended objectives.

Basic Considerations for Units

Planning for amphibious operations begins with receipt of a directive from higher headquarters and continues for the duration of the operation. Planners must consider—

Ž Mission and concept of operations of the landing force.

Ž Enemy disposition and capabilities.

Ž Terrain, weather, and hydrography of the landing area.

- Troops, tanks, ships, assault and utility helicopters, and landing craft available.

- Logistics-over-the-shore (LOTS) capabilities available.

The directive for an amphibious operation, intelligence reports, and information about available shipping are the basic tools with which to begin planning. Essential to planning is the continuing receipt of intelligence and timely requests for additional intelligence products.

Preparation of Tentative Plan

An armored unit OPCON to an infantry division participates in preparing the division's plan. Specifically, the unit commander considers armored or mechanized units in detail and makes recommendations on—

- The total number and type of armored units to employ.
- Task organization.
- Ž Missions and objectives.
- Ž Place and manner of landing.
- Ž Time of landings.
- Ž Coordination with naval gunfire air, artillery, infantry, and engineers.
- Antitank protection.
- Ž Special measures for communication, supply, and maintenance.
- Ž Special requirements.
- Requirements for assault shipping and landing craft.

Organization for Combat

Armored battalions may be under the division's control or attached to a brigade. Commanders may employ them as a unit, attach one or more companies to infantry battalions, or employ them as the nucleus of a tank or armored task force. Commanders cross load key weapons systems and units to minimize complete capability loss.

The landing force commander must resolve the requirements to separate tactical units on the one hand and centralize or distribute support elements on the other. He must specify how to do this in his plan for combat. He must review this issue continuously during the operation. Command relationships may be in effect before embarkation or on landing, depending on the landing plan.

Landing Plans

The most important point of a landing plan is that it must support the scheme of maneuver of the landing force ashore. Some basic considerations for armored units are—

Ž They must be ashore early to assist dismounted infantry in seizing initial objectives rapidly or to perform reconnaissance and security.

- They are a valuable weapon in protecting landing forces from early attack by mechanized forces.

Ž If they land early, armored units tend to reduce casualties among the dismounted infantry. They are a morale factor in early stages of the assault.

Ž Armored units should land early when the mission demands tanks as part of a task force.

- Key pieces of equipment and units are cross loaded to avoid complete loss of capability.

Armored units or vehicles may land in a scheduled wave or by the on-call method. This method is appropriate when conditions ashore are unsatisfactory for the landing of vehicles and the beach must be prepared for landing. The method selected should best suit the situation. It should also be the most efficient method of ship-to-shore movement. The division may organize armored units for the landing by either of two methods:

Ž Units are attached to a brigade landing team for the landing and assault of the beach.

Ž Units remain under the command of the armored unit commander until they have landed. Attachments to accomplish task organization may become effective upon landing or as stated in orders.

Embarkation Plans

The use of large-capacity landing craft and ships, and the time required in loading and unloading, demand detailed planning for embarkation. The anticipated tactical employment of the division determines the type and number of helicopters landing craft and landing ships required. Several factors govern the determination of the type of landing vehicle, including—

- Scheme of maneuver.

- Characteristics of the beaches.
- Presence or absence of offshore obstacles.

When possible, tactical considerations should govern the planned use of shipping. However, available shipping will seldom support the tactical plan without adjustment.

When shipping assignments have been made, unit embarkation officers prepare ship-loading forms and submit them to the ship's commanding officer for approval. When approved, they constitute the final loading plans and govern the loading of the ship. Changes can be made only with approval of the ship's commanding officer and the commanding officer of the troops concerned. Unit leaders should refer disagreements to the next higher level of command for resolution.

The DTO is responsible for division surface movement planning. Navy and Marine Corps personnel may be attached to maneuver battalions to serve as unit embarkation officers.

Logistics Plans

The division's tactical plan (and the logistics plans of higher echelons) determines logistics requirements. No rule determines the supplies which units carry and those higher echelons provide. The division determines the equipment and supplies each echelon will carry. It bases its directives on the overall plans for the operation and previous usage factors. Means of logistic support depends on the—

- Duration of the operation.
- Shipping available.
- Ž Type of operation.
- Estimated date of arrival of supply shipping.
- Ž Method and means of unloading.
- Ž Size of the objective.

During the planning phase, units must procure supplies and equipment required for training, embarkation, and initial phases of the actual operation.

Units must obtain fuel, ammunition, rations, repair parts, and special supplies and equipment.

This includes waterproofing equipment, cold weather equipment and clothing, special munitions, and vehicle accessories or attachments.

Shipping

The type of shipping available to the division affects landing. Ships suitable for landing armored vehicles are landing ships and landing craft. Ships differ in their capabilities, cargo, and troop capacity. The commander can develop final embarkation loading plans only after studying characteristics of the ships used. These characteristics are described in the ships' characteristics pamphlets. Direct liaison with ships' officers will also provide information.

Preparation for Embarkation

Unit embarkation officers and Navy commanders prepare loading and embarkation plans for units before the arrival of assault shipping at the embarkation point. Vehicle crews and maintenance personnel embark with their vehicles.

For each ship, the commanding officer of troops and the ship captain's representative arrange other details of embarkation. These include—

- Ž Assignment of personnel to billets and working parties.
- Ž Stowage of fuel, lubricants, and maintenance materiel so that these items are available for servicing vehicles and weapons.
- Organization of security and messing procedures aboard ship.
- Provisions for use of ships' equipment and personnel to assist in servicing equipment *en route*.
- Ž Provisions for en route training if feasible.

Embarkation

Units must maintain unit integrity as they embark. Normal organization for combat must remain unchanged. The landing ship, docks (LSDs) and landing ship, tanks (LSTs) because of their greater capacity, assist in maintaining unit integrity. To expedite the loading operation, personnel must be familiar with different methods of ship loading. This often requires extensive training.

Movement to the Objective Area

All personnel must understand their duties and be thoroughly familiar with the overall plan. Each leader must know the relationship of his mission to the overall plan in the amphibious attack. Briefings for personnel emphasize the—

• Mission.

• Scheme of maneuver.

• Details of the beach assault.

• Procedure for the ship-to-shore movement.

• Location and methods of communication with CPs, liaison personnel, and the naval control organization.

• Condition of beaches, nature of obstacles, beach exits, terrain inland, and terrain trafficability.

• Plans for location of maintenance and supply facilities ashore.

• Enemy situation.

Unit leaders should disseminate to all personnel intelligence information received during the movement. Vehicles should be loaded so they are accessible for servicing during the voyage. Designated personnel must plan, schedule, and perform daily servicing and final preparation for combat. This includes—

• Prestarting checks.

• Daily running of engines.

• Constant preventive maintenance on armament and communications equipment.

Ship-to-Shore Movement

Landing craft and landing ships influence the ship-to-shore movement of units. If a waterborne deployment of combat units is necessary to seize defended beaches, assault forces land from dispersed shipping in waves of small craft and amphibian vehicles over widely separated beaches. Heavy forces should land early so they may facilitate the infantry's seizure of initial objectives.

Personnel should preload in landing crafts, utility (LCUs) or landing crafts, mechanized (LCMs), which then launch from LSDs in the unloading area. Landing craft then assemble and proceed as a group to the LD. They either deploy

and cross in scheduled waves, or layoff in a designated area awaiting the order to land in on-call waves.

Because of the shallow draft of the LCU and LCM, vehicles should make a relatively dry landing. However, they need guides—individuals, markers, or buoys—to ensure they reach shore without striking mines or other obstacles.

Once ashore, armored units join infantry units. These task-organized units will execute the beach passage, seizing enough ground to protect the beach from small-arms fire. These units continue to expand the beachhead and execute the mission in accordance with the force commander's intent and OPORDs.

Time and Place of Landing

In an amphibious operation, armored units are needed as soon as the initial wave of assault troops land; therefore, they should land at the earliest possible time. Armored units may land in advance of, or with, the infantry against an undefended beach. However, a beach strongly defended by antitank weapons and obstacles prevents an early landing.

The commander must select a place and time of landing that supports the scheme of maneuver. The type and number of ships and crafts available to transport the force may determine where the unit lands and the rate of buildup ashore. The beach gradient, offshore reefs or sandbars, navigability of approach lanes, and waters surrounding the objective also influence choice of the landing site. Beach soil should be trafficable and its gradient gradual. It must have enough routes of egress to sustain momentum. It should support the scheme of maneuver. Offshore reefs barring passage of heavy landing craft, a poor gradient for beaching, poor trafficability, or the need to emplace causeways will delay the landing of armored forces.

Breaching teams must overcome or breach minefield and obstacles before the main unit landings. This minimizes losses and sustains the momentum of the attack. They should avoid natural or manmade obstacles offshore, on the beach, or inland or should select a site where they can breach the obstacle most easily.

In selecting the landing site, the commander must consider trafficability inland from the beach. Terrain inland should provide ample maneuver area, a suitable road net, and cover and concealment.

Obstacle Clearance and Breaching

Navy and landing base specialists must clear beach and underwater mines and obstacles rapidly. Navy underwater demolition teams clear underwater obstacles seaward of the highwater mark, usually during the preassault phase. The landing force clears mines and obstacles inland from the highwater mark. Time seldom permits removal of all obstacles. Only certain routes across beaches will be clear for passage early in the landing. It is often necessary to alter the prescribed landing formation and submit to some canalization during the beach passage. To reduce lateral movement to reach the cleared lanes, units on the beach must immediately relay information to commanders of LSTs and appropriate control vessels. This enables units afloat to land as closely as possible to the cleared lanes. Lanes selected should correspond to planned landing points. They must ensure—

- Sufficient breadth to accommodate vehicles.
- Sufficient numbers to permit rapid egress from the beaches.

~ Access to a road net or trafficable area.

~ A minimum of lateral movement after units have landed.

- Identifiable landing points leading to cleared lanes.

These lanes are of primary importance. If armored forces are used, their personnel and equipment should assist in clearing them. Reconnaissance personnel join with engineers to form teams. They assist in the demolition and removal of obstacles and selection and marking of lanes. They also guide vehicles through lanes. Other support includes the tank-mounted bulldozer, landing vehicle, engineer or combat engineer vehicles for obstacle removal, and armored vehicles for obstacle destruction and team protection. Analysis of specific obstacles determines the organization of mine and obstacle breaching teams.

Breaching teams should land with the leading waves, often with the first wave. Each team clears at least one vehicle lane 18 to 24 feet wide.

Guiding Vehicles Ashore

Landing conditions may require units to cross reefs, tidal flats, or other areas covered by shallow water. Operators must guide vehicles around obstacles. An amphibian tractor can guide vehicles ashore after debarkation. If this method is used, a guide vehicle should be designated well in advance of the landing to allow for briefing and communications planning.

A crewman may dismount and become a guide by wading ahead of the vehicle. This method is slow, especially if the water is deep or the bottom is rough. Guides are vulnerable to hostile fire. This method is satisfactory for short distances only.

Passage of the Beach

To avoid congestion and losses at the waterline and on the beach, units must carefully plan and coordinate passage of a beach area. They must conduct it aggressively. Liaison, reconnaissance, and breaching teams must perform their tasks quickly and thoroughly. As the vehicles emerge from their landing craft, guides meet them and direct them through cleared lanes to points from which they will support the attack. Armored units may support the infantry beach assault with small-arms fire from machine guns while engaging hard targets with main guns. Bulldozer tanks or combat engineer vehicles cover openings and entrances to emplacements. They aid in breaching operations inland. They can help improve the newly seized beaches if the tactical situation ashore permits.

Integrated assault teams transported in vehicles can make mass landings against undefended beaches. They can debark from landing ships directly onto the beach and attack inland.

During ship-to-shore movement, unit commanders should receive information by radio from their reconnaissance and liaison personnel ashore. This includes such information as the condition of the beaches, progress of beach clearance efforts, and recommendation of the best beaches for vehicles to land on. After landing, these

personnel meet vehicles at the edge of the water. They inform commanders of the best routes across the beach. Guides then lead them through the cleared lanes.

If intelligence is complete, no mines are on the beach, and hydrographic conditions are favorable, armored units may land in the first wave. They should land from two to five minutes ahead of the initial wave of infantry. The commander must time the landing and the initial wave of troop-carrying craft precisely to obtain maximum effect from shock and firepower. He should provide infantry support early on in the assault. If there is heavy enemy resistance at the waterline, armored units should land in a line formation to exert maximum firepower on the enemy.

Rehearsal

The rehearsal of the amphibious operation is critical. Participating forces should conduct one or more exercises under conditions approximating those anticipated for the actual operation. Units should conduct rehearsals according to a plan which approximates the plan for the actual operation. Responsibility for rehearsal planning is the same as for preparing the actual operation plan.

WINTER AND COLD WEATHER OPERATIONS

Extreme cold weather conditions pose significant operational problems for infantry divisions. In more temperate climates, many conditions discussed in this chapter have a minimal operational impact. In the cold, however, these same conditions are a matter of life and death. Proper equipment, training, and strong leadership can overcome cold weather problems and complications. Winter and cold weather operations include operations in snow, any cold region of the world, the far north, and in northern latitudes. World Wars I and II and the Korean War all included cold weather operations. Ten German divisions operated under arctic conditions in northern Finland in World War II in an area about 400 miles wide, while the Russian Army used 47 divisions in winter operations against Finland in 1939. Future global or regional conflicts may require divisional operations in a winter or cold weather environment. FM 90-11 is the Army's base doctrine on cold weather operations. This

chapter provides an overview of environmental considerations for such operations.

The Commander

Commanders must approach operations in cold weather in a positive manner, exploiting advantages and reducing disadvantages as much as possible. They must emphasize the feasibility of operations, and transmit their confidence to their subordinates.

Commanders face no changes in doctrine or principles and, in general, use tactics suitable for the terrain. However, operations in cold weather regions pose additional difficulties which greatly complicate C², maneuver, FS, and CSS missions.

Although the fundamental principles of warfighting apply, special characteristics of operations in cold weather increase commanders' responsibilities. Commanders must consider the use of special clothing and equipment and expedients and improvisations for living and moving in the cold. With proper training, suitable equipment, and effective, resourceful leadership, light infantry divisions can operate without significant loss of strength or effectiveness in the cold.

Winter and Cold Weather Considerations

Whiteout

A whiteout is an atmospheric phenomenon in which the light from the sky is about equal to that of the snow surface, and a uniformly white glow appears to engulf observers. Whiteout occurs over an unbroken snow cover and beneath a uniformly overcast sky. Blowing snow can also cause whiteout. Shadows, the horizon, and clouds are no longer visible. Observers lose depth perception and become disoriented. They can only see very dark and nearby objects. These conditions affect observers in the air as well as on the ground and increase soldier fatigue.

Greyout

Greyout occurs over a snow surface during twilight conditions or when the sun is close to the horizon, and when the sky is overcast with dense clouds. Surroundings have an overall greyness. The absence of shadows causes a loss of depth perception, increasing the hazards of landing aircraft, driving a vehicle, or even walking. Under

certain greyout conditions, drivers find it almost impossible to distinguish the road from a ditch or snowbanks along the roadside. Greyout is similar to whiteout. In greyout conditions, the horizon is distinguishable; during a whiteout, it is not. This condition can be overcome by the use of night observation devices by pilots, drivers, and soldiers.

Ice Fog

Ice fog is a phenomenon common in inhabited areas when temperatures drop below -35°F. At these temperatures, stagnant air cannot hold the water vapor produced by human activities; the vapor materializes as ice fog. Sources of water vapor include vehicle and aircraft exhaust, steam from heating systems, and even air from humid rooms. In the field, such fogs may appear over troops, bivouac areas, motor parks, airfields, convoys, and gun positions, disclosing the location of military activity. Ice fog can obscure a gunner's vision even with a thermal sight. When combined with soft snow blown up by muzzle blast, the condition may require a gunner to move to another position after the first shot. Ice fog can limit or negate the effectiveness of night vision devices (NVDs).

Snow Cover

Snow cover can increase the possibilities for movement and operations of suitably equipped and trained light infantry troops. It will significantly reduce the mobility of a force which lacks proper equipment and training. Snow cover reduces vehicle mobility, and snow over 1 meter deep will stop all wheeled vehicle movement. Wheeled vehicles can operate on established roads and in rear areas only. Full-track vehicles with low ground pressures are best for movement over snow-covered or muddy terrain. Deep snow often limits depth in combat missions because movement is slow. Snow depths over 24 inches will almost entirely stop movement on foot without the aid of snowshoes. Reconnaissance by patrols on skis, snowshoes, or in light oversnow vehicles should precede unit movement. Reconnaissance reports should include information on snow depth and ice thickness. Snow and ice increase the maintenance requirements of equipment and weapons systems. Snow cover reduces the effect of all weapons fires. The effects of field

artillery or mortar fire are significantly reduced by deep snow.

Ice Cover

The freezing of rivers, lakes, and swamps can increase the possibilities for maneuver. Waterways that are normally obstacles in summer can become frozen routes of advance and LOCs in winter, making extensive cross-country movement possible.

Extreme Cold

Extreme cold slows activities by numbing soldiers and increasing the need for maintenance of weapons and materiel. Activities which normally require only minutes may require hours in extreme cold. Oversnow movement is extremely slow and requires periodic stops to set up warming tents for the thawing of water and rations and for soldiers to combat the effects of numbing cold. Troops require special clothing and heated shelters and some equipment and supplies must be protected against freezing temperatures. Soldiers must winterize their weapons and vehicles with special lubricants. The commander must consider these factors in his planning. Proper planning and suitable clothing, supplies, equipment, shelter, transportation, and intensified training can reduce the effects of extreme cold.

Extreme cold affects equipment by making metal very brittle. Increased breakage of parts occurs in all types of weapons. Extreme cold also decreases ammunition velocity and accuracy. Bringing a cold weapon into a warm shelter causes condensation on the weapon which will freeze and cause a malfunction when it is taken back outside into the cold. Consequently, weapons are normally left outdoors unless brought in for maintenance.

Daylight and Darkness

Winter in arctic and subarctic regions brings decreased daylight and in some areas no daylight. Conversely, summer has long periods of daylight. The commander must not regard unusually long periods of either daylight or darkness as a bar to operations. In some situations, these conditions will actually aid operations.

Low-Population Density and Transportation Routes

Settlements, supplies, quartering facilities, and LOCs are normally limited in arctic regions. Their control or destruction may be critical. Roads and railroads may be limited and those that exist usually are vulnerable to enemy action. In addition, climatic conditions may greatly affect their use.

Lakes and waterways may either aid or hinder operations. They can be used as natural routes of communication or airstrips if covered with ice of sufficient thickness; however, drifted and hard-packed snow may make landing on ice difficult and require engineer preparation of an airstrip. In the summer, waterways may be either major barriers or LOCs. Many rivers and streams are glacier-fed and carry great volumes of water and silt in summer. The amount of water may vary considerably during any 24-hour period. This is particularly true near a river's source when daytime temperatures are warm and nighttime temperatures are near freezing. Careful reconnaissance is required to determine changes in water volume throughout the day.

Mapping and Navigation

Lack of landmarks, large forested areas, periods of reduced visibility, difficulty of cross-country movement, and large magnetic declination variations (in extreme northern and southern latitudes) increase the difficulty of land navigation in some regions. Maps may be unreliable, or nonexistent. Therefore, GPS and aerial photographs become an important source of terrain information. With proper planning, engineer topographic units can convert aerial photography into photomaps. Unless the aerial photographs are properly laid out, annotated, and referenced to known survey points, they will not be accurate enough for navigation and indirect fire weapons.

Weather Variations

Sharp variations in weather are common in cold weather operations. These include severe frosts, mild spells, thaws, rain, sudden freezing, snowstorms, strong winds, and dense fogs. Rains can halt an attack by making off-road movement

impossible. Conversely, a hard freeze can make a defensive position vulnerable by converting soft lowlands, or even rivers, into avenues of approach.

Accurate weather forecasts are essential to guard against the harmful effects of weather and to seize tactical advantage. The division weather section and its weather prediction capabilities are extremely important. The commander must consider favorable conditions of even short duration as a combat power multiplier over the enemy.

Seasonal Transition

Climatic changes are abrupt as seasons change. A frozen river may become a major obstacle as the ice breaks. Temporary roads and airfields disintegrate, and permanent ones become unusable. Rivers flood. Terrain changes rapidly. Winter field fortifications can become unusable. In the arctic, areas underlain by permafrost become bogs in summer. When possible, air reconnaissance should be used to determine possible routes for movement.

The freezing season is shorter and has less effect on movement than the break-up season. The best time for operations is when ground and waterways freeze sufficiently, but before deep snows arrive. Careful planning is essential. In winter, clothing and shelter must protect against cold; in summer, they must protect against water and insects. Large numbers of mosquitoes are common in arctic regions during warmer months. They can severely impact operations if troops are not properly equipped. Camouflage patterns also must be altered.

Delayed Responses

Extreme cold increases the time required to perform even simple tasks. Everything is done at a slow pace and takes considerably more time. Troops conducting movement require additional time to adjust clothing and equipment and, many times, must set up warming tents en route. In cold weather, soldiers must be supervised to ensure they consume sufficient quantities of food and water. Soldiers often resist performing routine hygiene functions due to the extreme cold. The establishment of buddy teams within an organization can assist in reducing cold weather injuries.

Operations

Errors or miscalculations in planning extreme cold weather operations may be disastrous, and corrective action, difficult. Synchronizing air and ground forces is more difficult in the cold.

Planning for logistics support must include increased fuel, shelter, and clothing requirements; the need for special equipment; and the need to modify standard items. Plans must provide for alternate means of supply and for increased use of air transport in supply and evacuation. Soldiers will be able to move only the minimum of essentials. Austere living and self-sufficiency are critical to economy in the use of supplies.

Reconnaissance

Operations in extreme cold are vulnerable to ambush and delaying tactics. Reconnaissance ahead and to the flanks of an advancing column is critical. Detailed reconnaissance before committing the main force avoids delay, misdirection of effort, fatigue, and unnecessary exposure of troops to the cold. Reconnaissance troops must be mobile, but still carry life support equipment. They must maintain communication with the main body at all times.

Security

Short hours of daylight and storms may restrict enemy air operations. However, the weather may also limit air and ground observation of the enemy. Dense forests provide a natural screen against air observation for elements not using roads or familiar trails. In open snow-covered areas, the use of a white covering for clothing and equipment increases protection against observation.

Extreme cold decreases the importance of water obstacles. However, concentrated artillery fire, air bombing, or deliberately placed demolition charges may turn frozen areas of water back into obstacles or traps. One foot of solid ice will carry light tanks while 3 to 4 feet of ice will support virtually any load. Snow over 18 inches deep will limit or completely stop use of wheeled combat vehicles except on cleared roads. It may also hamper operation of track vehicles.

Mines improperly placed will be ineffective in heavy snow as tanks press them deeper into snow without exploding them. If used, mines should be placed on a hard surface underneath the snow.

Offensive Operations

The commander must consider climatic conditions and sudden weather changes in planning offensive operations. Heavy snow may fall during an operation, restricting movement and mobility. It can also hinder movement of the enemy's reserve. A sudden thaw may prevent cross-country movement and cut off troops from adjacent friendly forces. Fog and low clouds can develop quickly and obscure observation. The commander should receive frequent weather reports to aid in decision making before and during operations.

If possible, the attacks should avoid heavy forests and snowdrifts. Terrain corridors between wooded areas are preferable to stream valleys, as the latter usually contains deep snowdrifts. The objectives of the attack are critical terrain features which dominate the roads leading away from the enemy's position. Their seizure will normally prevent withdrawal, reinforcement, or resupply and may cause the enemy's eventual surrender or annihilation.

Defensive Operations

In general, reasons for assuming the defense apply in all environments. Maneuver units may have to assume the defense due to extreme cold weather phenomena such as breakup, freeze-up, severe snowstorms, and extremely low temperatures. Units may deliberately assume the defense to tempt (or compel) the enemy to attack under unfavorable conditions such as through long, narrow passes, deep snow, or across obstacles where movement is difficult and firepower ineffective. This forces the enemy to fight under exhausting conditions while the defender occupies better shelter and has shorter supply lines.

The commander uses extensive reconnaissance to find the enemy flanks and rear and prevent surprise attacks. Highly mobile units should be used to harass the enemy's rear, forcing him to use combat forces for security tasks. They cut LOCs and destroy his bivouacs, supplies, and other installations. Destruction of the enemy's shelter places him in immediate jeopardy. This

can permit taking the offense as soon as the situation allows.

Wide frozen streams and lakes afford little or no cover to the attacker and provide excellent fields of fire for the defender. Under mild temperatures, keeping the ice of these lakes and streams broken up for a distance of 20 to 30 feet from shore creates a difficult obstacle. Heavily wooded areas and open areas relatively free of snow favor the attacker. Special attention must be paid to these areas and they should be defended in strength and in depth.

In conditions of extreme cold, the organization of a position requires special tools and explosives. Ordinary entrenching tools are ineffective. The location of a defensive position on the crest of a hill or ridge will usually be effective. Enemy tanks and personnel will have difficulty ascending a steep slope covered with snow.

The defender holds his most mobile troops in reserve. Because of difficulties in movement, the commander should keep his reserves closer to the probable area of employment. Maneuver units normally counterattack against the flank of an attacker. In deep snow, the enemy may be unable to change his orientation in time to meet a counterattack on his flank by mobile forces.

The defender continually improves LOCs. He opens paths between frontline positions and rear areas, and in the directions of reserve employment. The commander should position reserve units to cover thoroughfares to prevent use by the enemy.

DESERT OPERATIONS

The term desert covers a broad spectrum of arid environments, ranging from the rolling sands of the African Sahara to the mountainous and wadi covered American Mohave. These areas have certain characteristics which affect military operations: lack of water, limited vegetation, large areas of sand, extremes in temperature, and brilliant sunlight. FM 90-3 is the Army's base doctrine on desert operations. This section does not describe how to conduct desert operations, it provides an overview of the impact of the desert environment on men, equipment, and military operations.

The Desert Environment

Mountainous deserts have scattered ranges or areas of barren hills or mountains separated by dry, flat basins. Most of the infrequent rainfall occurs on high ground and runs off rapidly in the form of flash floods. These create deep gullies and ravines, and deposit sand and gravel around the edges of the basins.

Rocky plateau deserts have relatively slight relief and extensive flat areas with solid or broken rock at or near the surface. They may have shallow, but sharply defined, steep-walled valleys, called wadis. Although their flat bottoms and concealment may seem attractive as CP locations, wadis can be extremely dangerous to soldiers and equipment because of flash flooding after rains.

Sand or dune deserts are extensive flat areas covered with sand or gravel. Areas may be totally flat for several kilometers. Plant life may vary from none to scrub brush over 6 feet high. Temperatures may exceed 100°F during the day and fall to near freezing at night.

Impact on Operations

Mobility

The key to success in desert operations is mobility, clearly evident in ground operations in Operation DESERT STORM. The tactics employed to achieve victory over Iraq were wide, rapid flanking movements similar to those Field Marshal Rommel and Field Marshal Montgomery demonstrated in North Africa. Trafficability and cross country movement are critical to the tactics of desert operations.

Trafficability and cross country movement are generally good. However, salt marshes can create no-go conditions during the wetter season. Sand can bog down traffic and make foot movement slow and exhausting. The steep slopes of dunes and rocky mountains can make vehicular movement impossible. The wadis create cross-compartmented terrain, with their banks steep and unconsolidated. When it rains, wadis become dangerously rushing streams of water, turning flat lake beds into seas of mud. In rocky terrain, sharp angular debris punctures tires easily. But, overall, movement is mostly uninhibited. With

ample fuel and water resources, units can go around these natural, as well as man-made, obstacles.

With the desert's loose surface material, movement can be easily detected because of the flying sand and dust. In an actual engagement, this cloud may obscure a unit, thus protecting it from direct fire as it advances. But the element of surprise is probably lost.

Moving at night may be the logical choice. The dust is still there, and vehicles (which should be widely spaced) can get separated. But there is no worry about enemy detection from the sun's rays reflecting on glass, mirrors, or metal. This can give away movement and positions at distances of up to 20 kilometers.

With the ability to make fast wide flanking movements, a unit can encircle and cut off enemy forces. The Israeli forces under General Ariel Sharon did just that to the Egyptian Third Army in the 1973 War. The British did the same to the Italians in North Africa in January 1941. In Operation DESERT STORM, the night-fighting AH-64 helicopters, combined with field artillery fires, were an unbeatable team. An armored force raced to the Euphrates River and attacked Republican Guard positions, cutting off and destroying Iraqi divisions.

Land navigation is a challenge during movement in many arid regions. There are few landmarks to key on, and maps and even photos can become dated quickly, especially in the sandy deserts where dunes migrate. The GPS with the small lightweight GPS receivers (SLGRs) is a major aid for desert operations.

Refuel and resupply operations require periods in which forces assume the defense, but only temporarily. Compared to rocky plateau topography, the flat sandy desert topography that is characteristic of Saudi Arabia is not conducive to defense. In mountains and canyons, a defensive posture can be favorable. Controlling the passes can essentially close off vast areas to an attacker and make it extremely costly for him.

While a unit is in the defense, it needs both ground and air reconnaissance to detect movements at long range and as early as possible.

Obstacles must be placed in all types of topography, primarily to slow advances and channel columns. Neglecting these security measures in the flat sandy regions can lead to disaster.

Reports from commanders in DESERT STORM indicate that the enemy was engaged early and at the maximum ranges of weapons systems. In some cases, observed fires had to be used because the enemy could move so quickly. OH-58 helicopters, used with AH-64s and long-range artillery systems, were the means to this end. But, generally, the Iraqis moved little, and unobserved fires, using IMINT, resulted in substantial kills.

Observation and Fields of Fire

Observation and fields of fire are generally excellent in most desert areas. Open terrain and a predominantly clear atmosphere offer excellent long-range visibility and permit direct fire weapons to be used to their maximum ranges. However, range estimation by "gut feeling" may be subject to error. The effective ranges of weapons can easily be reached. Correct estimation of maximum ranges is critical for all weapons, especially for wire-guided munitions.

There are two primary considerations when using weapons in the desert environment: longer-range observation, and fields of fire at the maximum effective ranges. Rapid heating and cooling of the atmosphere can hinder these factors, however, and causes distortion of ranges to the aided and unaided eye. Mechanical and electronic means, such as ground surveillance radars and laser range finders, must be used to verify estimated ranges. Weapons must be bore sighted and zeroed more frequently at standard ranges.

The desert is not absolutely flat, so weapons are sited to provide mutual support. Dead space may be a problem. Even though the landscape appears flat, closer inspection may show it to be undulating with relatively deep wadis and depressions. These areas must be covered by indirect fire.

When on the offense, attacks should be initiated with the sun at or near the attacker's back whenever possible. This eliminates most shadows that degrade optical weapons guidance and make visual target acquisition difficult.

When there is no usable dominant terrain available, observation may be accomplished from the air.

Other visibility problems are caused by heat distortion, which results from heat waves at the desert surface. Heat distortion causes images to shimmer, making positive identification difficult and degrades depth perception. Also shines and reflections must be avoided. Range finders to verify correct distances and bracketing techniques with large adjustments can aid to hit an enemy target with artillery.

If optical vision is hopelessly distorted, radars can be valuable and they are unlikely to be affected by the haze of midday heat. However, radars are almost useless in sandstorms.

Image intensification, which depends on the phase of the moon at night, is also of limited value in sandstorms. If there is no moon, artificial illumination outside the field of view of the system is used. Since thermal imagery devices depend on the difference between ambient temperature and equipment temperature, they are more useful at night than during the day. Because of the distinct advantages, they should be used as the primary sighting systems for vehicles so equipped.

Observation of fires, especially direct fires by tanks, may be difficult due to dust clouds. Correction of field artillery fires, especially those of larger pieces, may be complicated by dust hanging in the air following the impact of ranging rounds. Forward observers should consider placing initial rounds beyond a target rather than short of the target.

Cover and Concealment

Cover and concealment are generally scarce in the desert. The flat sandy deserts provide little if any natural cover or concealment, especially from aerial attack or reconnaissance. Ground concealment and protection from fire can be found behind dunes or in wadis. When using wadis for ground concealment, soldiers must be aware of the potential for flash floods.

Some arid regions have vegetation that can provide limited concealment from ground observation. In rocky, mountainous deserts, cover and concealment are best behind boulders and in crevasses. Daytime vehicular movement eliminates nearly any possibility of surprise, as dust

trails created by the traffic can be spotted for miles. At night, noise and light discipline is critical. Both sounds and light travel great distances because of the unobstructed flatness and atmospheric stability. Camouflage can be very effectively employed to improve on natural cover and concealment.

Obstacles

Natural obstacles do exist in the desert, and arid regions are well suited for man-made obstacles. The wadis and steep slopes of escarpments, mountains, hills, and dunes hinder cross country movement. Sand dunes may stretch for miles and prevent direct movement across their length. These sand dunes are often more than 100 feet high and consist of loose sand with high, steep downwind faces that make vehicular traversing next to impossible. In the DESERT STORM area, the salt marshes have a crusted top that deceives vehicle drivers. These dry lake beds can become obstacles, especially in the wetter seasons when the water table is higher. A top crust forms on the surface, but below the crust, the soil is moist, similar to marsh conditions. The surface looks like it will have good trafficability, but the crust collapses with the weight of a vehicle, which becomes mired. The high premium on fuel and time makes it costly to go around these natural obstacles. Aerial reconnaissance immediately before any large movement is highly advisable because sand dunes migrate with shifting winds; they may not be where maps or even photographs show them.

Sandy deserts are ideal for employing minefield. Although windstorms can reveal previously buried mines, these mines can still channel movement and deny access to certain areas. The battles of the Bi'R Hacheim Line and El Alamein were influenced by minefield. Other obstacles include ditches, revetments, and barriers made by bulldozing sand mounds or by blasting in rocky mountainous areas to close passes. The Bar Lev Line along the Suez Canal is an example of such a barrier.

Key Terrain

Key terrain in the desert can be any man-made feature, a mountain pass or a source of

water, and, of course, high ground. Because there are few man-made features in the desert, those that do exist can become important, perhaps even key.

Roads and trails are scarce in the open desert. Complex systems beyond simple commercial links are not necessary. Routes joining oil or other mineral deposits to outlet collection points supplement these road systems. Wells, pipelines, refineries, and quarrying and crushing plants may have strategic and tactical importance. Pipelines are often raised off the ground, inhibiting movement. Rudimentary trails exist in deserts for use by minor caravans and nomadic tribesmen. Ancient posts and forts, usually in ruins, invariably command important avenues of approach. They frequently dominate the only available passes in difficult terrain.

Passes through steep topography are also likely to be key, again because they are so few. The North African campaigns of World War II focused on the control of passes, specifically the Sollum and Halfaya. In the Sinai Wars between Egypt and Israel, the Mitla, Giddi and Sudar passes were key. In Afghanistan, control of the mountain passes provided the Mujahideen safe haven from the Soviets. The oasis, where wells exist, become important for water resupply. The high ground is always a fair bet for key terrain. The relative flatness and great distances of some deserts, such as in Iraq, make even a large sand dune a dominant feature.

Avenues of Approach

Avenues of approach are not clearly defined in arid regions. The vast, relatively flat areas permit maneuver from virtually any direction. This point became obvious to units establishing defensive positions in Operation DESERT SHIELD. Wide envelopments are possible, as demonstrated in the DESERT STORM ground campaign. Modern sensor technology, limited natural concealment, and improved observation make the element of surprise a challenge. Yet, surprise was achieved during DESERT STORM. Iraqi commanders were shocked when they discovered US tanks in their perimeters.

Fuel is the major limitation when considering avenues of approach. The great distances a unit

must travel to outflank enemy positions require huge amounts of fuel and complicate resupply. In mountainous and canyon topography, avenues are much more limited; the wadis and the valleys are likely to be the only possible access routes. Any roads that do exist are probably in the valleys. Nevertheless, none of the considerations outlined above are reasons to preclude the use of such tactics.

Techniques for Operating Vehicles

The best time to drive on sand is at night or early morning when the sand is damp and traction is better. By reducing tire pressure, vehicles may gain some traction. However, prolonged driving on partially deflated tires will overheat the tires and break down the sidewalls. Loads must be evenly distributed and operators must apply good driving skills to avoid harsh jolting of tires and extreme wear on tracks, wheels, springs, and shock absorbers.

Sandy deserts may be broken up by wind-blown dunes. Crossing dunes requires careful reconnaissance. Units should stay on the upwind side if possible. The wind may have built up sand around small scrubs forming small hills. Wheeled vehicles should not attempt to move through areas where this has occurred. Salt marshes, found in many deserts, are normally impassable, especially those with a dry crust of silt on top. A surface crust will cover some sandy areas, which may impede travel.

Vehicles should carry at least enough pierced steel planking or galvanized iron for the driving wheels. Sand mats are also effective; these are made of canvas, preferably with lateral strips of metal for strength and traction. Other essential emergency equipment includes jacks, jack blocks, tow ropes, shovels, axes, and picks for use in vehicle recovery. Winch-equipped vehicles should not normally lead movements.

JUNGLE OPERATIONS

Jungles occur in tropical and semitropical areas throughout the world. The US Army has a long history of fighting in jungles—in World War II, Vietnam, and, most recently, in Panama. Because Army contingency plans include many operations in jungle areas, jungle warfare for infantry division remains a distinct possibility.

FM 90-5 is the Army's base doctrine for jungle operations.

Jungle Environment

Jungles are characterized by dense vegetation, high temperatures (averaging 78 to 95°F), high humidity (90 percent), and heavy rainfall (1,000 centimeters or 400 inches per year). In jungles that are close to the equator, seasons are nearly alike, while further from the equator there are distinct wet (monsoon) and dry seasons.

Types of Jungles

Primary jungles are tropical forests with well-established trees. Primary jungles include tropical rain forests and deciduous forests.

Tropical rain forests have large trees whose branches interlock to form canopies. Canopies may form at two or three different levels, and prevent sunlight from reaching the jungle floor. As a result, there is little undergrowth. This makes movement by foot easier than in other types of jungles. However, extensive above-ground roots, hanging vines, and soggy ground makes vehicular travel difficult. Observation from the air is nearly impossible and ground observation is limited.

Deciduous forests are found in subtropical zones. In wet seasons, trees have their full foliage, while in dry seasons much of the foliage dies. Trees are less dense than in the rain forest, with more sunlight and rain filtering to the jungle floor and, consequently, more undergrowth. In the wet season, observation from the air and ground is limited and movement is more difficult. In the dry season, observation and trafficability improve.

Secondary jungles occur where the ground has been repeatedly exposed to sunlight, primarily at the edge of a primary jungle and in areas where jungles have been cleared and abandoned. Secondary jungles are overgrown with weeds, grasses, canes, and other vegetation. Foot movement is difficult, and ground observation is limited to a few meters.

Common Jungle Features

Jungle areas are not characterized solely by trees and undergrowth. In the tropics and

subtropics, local areas in the jungles have special characteristics. These areas include swamps, savannas, bamboo thickets, and active or abandoned cultivated areas.

Swamps occur in low jungle areas or depressions with poor drainage where water can gather. Movement is normally limited to foot and small boats. Air and ground observation is limited.

Savannas are broad, open jungle grasslands in which trees are scarce and grasses thick and broad-bladed. Vehicle movement is easier in savannas than other jungle areas, but movement by foot is slow and tiring because of the tall, sharp-edged, dense grass. Observation varies from poor to good.

Bamboo grows in jungles throughout the tropics. Large stands of bamboo can obstruct vehicle movement. Troop movement through bamboo is slow, tiring, and noisy.

Cultivated areas include rice paddies, plantations, and small farms. Generally, observation is less restricted in cultivated areas. Ease of movement varies. Rice paddies are flat fields that are flooded during part of the year through a series of dikes and irrigation ditches. Paddies hinder foot movement when wet and generally prevent vehicle movement whether wet or dry. Plantations are large farms where tree crops like rubber and coconut are grown. The ordered rows of trees generally allow easy movement. Small farms are created by cutting down and burning off existing jungle vegetation. Crops are grown for a few years, then the farms are typically abandoned. These abandoned farms may hinder movement when they become overgrown.

Operations

Combat in the jungle is characterized by long periods of developing the situation and looking for the enemy, followed by short periods of violent and sometimes unexpected fighting. Jungle combat involves fewer conventional attacks and defenses, and more ambushes, raids, and meeting engagements. Heavy vegetation reduces observation and fields of fire, which makes high ground less significant as key terrain. Roads, rivers and streams, fording sites, and landing zones will likely be key terrain. However, the operational

orientation remains on the enemy, rather than on retaining or controlling terrain.

The range of TOWs and Dragons is very limited in the dense jungle vegetation. Artillery fire support is difficult to observe and adjust. TACAIR and helicopter weapons systems provide an alternative to conventional artillery fire support.

Navigation and Mobility

Topographic survey of jungle areas is mainly by air. Jungle maps will show large terrain features, but do not always show smaller features such as gullies, small swamps, and intermittent streams. Older maps may be inaccurate, especially in depicting trails and clearings that can be overgrown rapidly. Aerial photographs and information from patrols, local inhabitants, and others who have been in the area, can help update maps.

Heavy vegetation makes land navigation more difficult. Use of the compass and an accurate pace count are vital. If available, the best source of navigation is the GPS. Movement through the jungle is difficult and slow. Thick vegetation and lack of roads hinder vehicle movement. Dense vegetation, heat, and rugged terrain cause troops to tire quickly.

Communications

The jungle environment has a negative effect on communications. The dense foliage reduces the range of both visual and sound communications. Radio range is reduced, typically by 10 to 25 percent, due to thick foliage and rugged terrain. Rain and humidity can cause communications equipment to fail. Laying wire for communications takes more time. Aircraft may be needed to assist in wire-laying operations.

Offensive Operations

The jungle environment poses several challenges for the attacker. Thick foliage hinders seeing the battlefield and requires the coordinated use of security patrols, air and ground reconnaissance, and movement. The momentum and speed of an attack are difficult to maintain. Thick vegetation makes it difficult to move and accurately fire heavy weapons. The

jungle does, however, provide concealment for infiltration. (See Figure 8-7.)

Defensive Operations

The density of jungle foliage impedes detection of approaching enemy forces and slows movement in reaction to an attack. Because foliage limits fields of fire and decreases visibility between positions, defensive positions normally must be closer together. The defending force must use OPs and NVDs to provide early warning, especially against infiltration attempts. (See Figure 8-8.)

Combat Service Support

Lack of roads in the jungle hinders resupply and evacuation. Air transport is critical for resupply but not always available. Soldiers must be able to move with only the minimum of essential supplies. Austere living and self-sufficiency may be critical to jungle operations.

RIVER CROSSING OPERATIONS

Infantry divisions may be required to conduct river crossings during both offensive and defensive operations. However, infantry divisions require extensive augmentation of engineers, FS, AD, chemical (smoke), MP, EW, and aviation (both lift and attack). FM 90-13 is the foundation for the conduct of river crossings.

Offensive River Crossing Operations

River crossing operations facilitate moving division units across the water obstacle so that there is minimum impact on the division's ability to move and project its combat power. Infantry divisions cross rivers via air assault, airborne, hasty river crossings, or deliberate river crossings. Divisions normally conduct river crossings as part of a corps operation.

Planning Considerations

The focus of offensive river crossing operations may be to destroy the enemy's defense in depth along with securing a bridgehead. If a bridgehead is to be used as a control measure, it must be large enough to accommodate the force and facilitate continuation of the operation.

Generating combat power across the river is crucial. Crossings should be conducted on as wide

Techniques:

Greater dependency on GPS and aerial observers as land navigation aids. Aerial observers provide course and route guidance.

Graphics tied to terrain features.

Phase lines may be used as a permissive fire coordination measure. Shifting from one phase line to another is event-driven. Flexibility and control of indirect fires is accomplished through an execution matrix. Boundaries are beyond maximum effective range of enemy and friendly direct fire weapons. Boundaries and restrictive fire control measures are positioned to allow immediate suppression missions, force protection, and security.

Control is achieved by assigning responsibility for an AO. Brigades identify objectives within commander's intent and available intelligence. In this scenario, 2d brigade in the north lacks information and intelligence on enemy strength and location. The 1st brigade in the south has better information. Aviation initially screens across the entire front. A boundary change occurs (affecting aviation) when 2d brigade crosses PL SKUNK.

Permissive fire control measures are facilitated during movement by a combination of aerial observers and GPS. The control measure is designated by GPS location plus a specified distance. Lacking favorable conditions, greater reliance is placed on aerial observers.

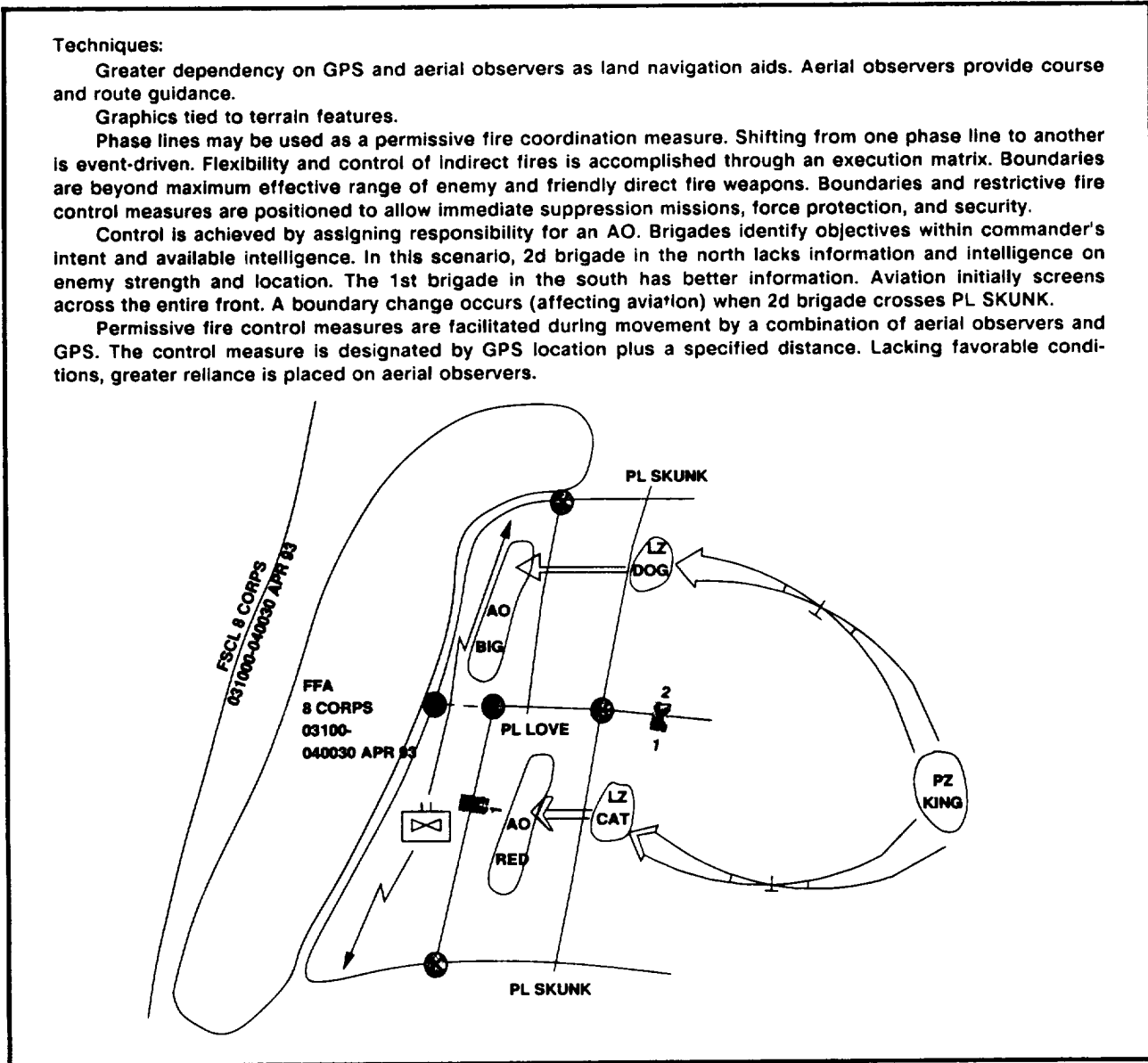

Figure 8-7. Example offensive jungle operations

a front as possible, using as many crossing sites as possible. Crossing at night, during reduced visibility, using obscurants, and developing a deception plan are all means to reduce the vulnerabilities inherent in river crossing operations.

Throughout a river crossing operation, the crossing force must be capable of defeating or blocking anticipated enemy reaction, including counterattacks, on the far bank. Plans must provide for a rate of crossing and buildup of combat

power on the far bank that exceeds the rate at which the enemy can concentrate against the force. The crossing force secures sufficient space (bridgehead) on the far bank to provide adequate maneuver room and a depth sufficient to successfully conclude the river crossing operation.

Corps normally retains approval authority for river crossing operations to ensure that flanks are tied in with adjacent units. A further reason for corps control of the bridgehead planning is that

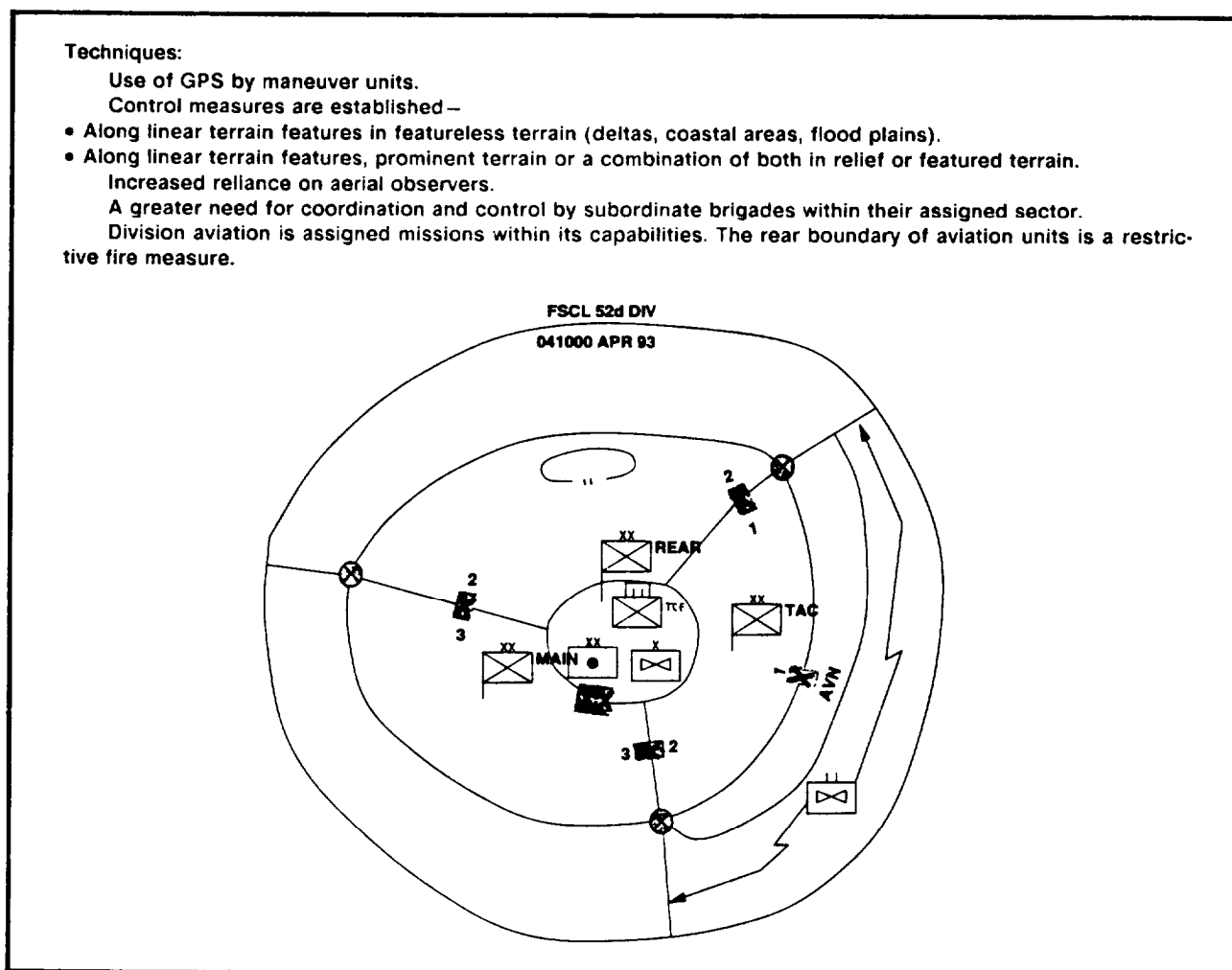

Figure 8-8. Example defensive jungle operations

although the actual assault is conducted by the divisions, substantial corps assets (such as artillery and engineers) are normally attached to the divisions to provide the necessary means to carry out the crossing.

Although a bridgehead line is the normal graphic used to designate the forward boundary of the bridgehead on maps or overlays, other combinations of graphics may be used, depending on the degree of control desired by the control headquarters. In lieu of a line, a series of key terrain features that mark the desired trace may be shown as objectives, thereby defining the bridgehead. A combination of a line and objectives may also be used.

The area comprising the division zone within a corps bridgehead is called the division objective area. It is bounded by the corps bridgehead line in zone, the division's flank boundaries, and the river itself.

Provision should be made for flank security of the bridgehead by tying the ends of the bridgehead line into the river obstacle itself. Where possible, flanks should include good defensible terrain.

A river crossing plan may be a separate OPLAN or OPORD or it may be an annex to an OPLAN or OPORD. If the primary or sole task is to secure a bridgehead, it is normally prepared as an OPLAN or OPORD. If not, an annex is

prepared. In either case, the format resembles a complete order. Divisions routinely phase their river crossing operations.

METT-T will determine force ratios, but for river crossings in the offense, a greater than 3 to 1 ratio is normally required. However, under extremely favorable circumstances, it may be possible to cross a river and secure the entire objective area (the bridgehead) in a single sustained attack. This type of crossing and securing of the area in one phase may be feasible when the enemy is incapable of significantly delaying the advance of forces making the initial assault crossings or of disrupting subsequent operations.

An offensive deliberate river crossing has four phases. They are distinct in planning, but there is no pause between them in execution:

- Phase I. Advance to the river.

ŽPhase II. Assault across the river.

- Phase III. Advance from the exit bank.

ŽPhase IV. Secure the bridgehead line.

(See FM 90-13.)

Synchronization

Engineer Assets. Corps engineer assets, to include combat engineer battalions and assault bridge companies, will be placed OPCON or DS to the division under the C² of an engineer group headquarters. Additionally, assets may be received from in-place US or allied nations. In the latter case, extensive liaison will be required between attacking forces and those in-place.

Chemical Unit Smoke Operations. Chemical operations provide large-area, long-duration smoke to conceal emplacement of crossing means, such as bridges or rafts. They also support deception by drawing attention to a false crossing site.

Fire Support. Fire support must be integrated into the overall maneuver plan. Supporting fires available to river crossing operations may include field artillery, attack helicopters, CAS, and perhaps naval gunfire. The main missions for the FS systems in river crossing operations are to—

- Destroy and suppress enemy direct and indirect fire.

- Isolate the crossing sites and the bridgehead.

ŽProvide interdiction fires, particularly against movement of enemy reserves.

ŽProvide illumination and smoke.

- Suppress and destroy enemy air defenses and C² facilities.

- Deliver scatterable mines to protect the flanks, support the defense of the bridgehead, and restrict enemy activity in the vicinity of the obstacle.

Air Defense. River crossing operations are highly vulnerable to enemy air attack. Their vulnerability is caused by—

- Restriction on the movement of the attacking friendly forces.

ŽConcentration of forces in the buildup for the operation.

- Exposure of personnel and equipment to enemy observation while crossing the river.

ŽDifficulty and delay which may be involved in crossing the river.

ŽNatural avenues of low-altitude air attack that rivers afford.

These vulnerabilities and the importance of the river crossing to the overall operation require that lead divisions be given a high priority for allocation of corps air defense assets.

Movement Control. The aim of the movement control plan is to speed movement across the river and maintain the momentum of the operation. To accomplish this, a maintenance and refuel site should be established on the friendly side of the river. This will help maintain the momentum. The plan requires detailed coordination between movement control agencies and maneuver forces, to include in-place forces and corps where applicable.

Crossing sites are normally selected by the brigade commander. Division may specify crossing sites when a certain location is critical to the tactical concept. The factors of METT-T determine the number of crossing sites. Depending on

available resources, it is desirable that each assault battalion have at least one good assault crossing site in its zone. Control of the crossing sites generally reverts to the corps on movement of the lead division's essential CS and CSS assets across the obstacle.

Deception operations include feints, demonstrations, ruses, and displays. The objectives of the division deception effort are normally part of a corps deception. Deception considerations include:

- Concealing the location and strength of force buildup.
- Concealing the location of the proposed crossings and, within it, the main effort.
- Causing the enemy to reveal his defensive fires.
- Causing the enemy to shift his fires from the main effort.
- Causing the enemy to commit reserves improperly against the bridgehead or to delay commitment of reserves.

Deception measures must be plausible to the enemy. A feasible course of action discarded in the planning may provide a good basis for a deception plan.

Retrograde River Crossing Operations

A retrograde river crossing is a special operation that requires detailed planning and support. Normally, the extent of the water obstacle and the enemy situation will dictate just how the crossing will be accomplished.

A retrograde river crossing is usually conducted when enemy advances threaten to overwhelm the division. The commander responds to this situation by directing the execution of some form of retrograde operation. While executing a retrograde operation, the division may be subjected to possible enemy pursuit. In such a situation, the retrograde river crossing may be conducted to accomplish one of two objectives:

- To establish a new defense on the exit bank of the river.
- To continue the retrograde to new defensive positions designated beyond the obstacle.

Retrograde river crossings are not merely offensive river crossings conducted in reverse. Retrograde river crossings are characterized by the following:

- Detailed planning and centralized control.
 - Enemy control of maneuver initiative.
 - High risk to friendly forces.
- Use of delaying forces to impede the enemy's advance and to trade space for time at the crossing sites.
- Forces on the exit bank providing defensive and overmatching fires.

The retrograde river crossing should be conducted with the same amount of detailed planning that is associated with a deliberate offensive crossing. For planning purposes, the crossing operation is divided into three distinct actions: delay, defense, and crossing. Even though these actions are distinct, they take place concurrently on the battlefield.

The *delay's* primary purpose is to trade space for time. The time gained allows the main body of the corps to move across the river. The corps elements not engaged in the delay execute a planned retirement or withdrawal and cross the river as quickly as possible. These elements are assigned various missions within the crossing area or in the defense which is established on the exit bank. The movement of these elements toward and across the river should be consistent with the overall retrograde being conducted by the entire corps. This is required to preclude the enemy's early detection of the actual crossing sites.

The commander will direct that delay operations continue until delay forces reach the battle hand-over or holding line. At this time, the units which have repositioned and occupied assigned defensive positions on the exit bank assume responsibility for the battle. The delay force then disengages and begins its rearward crossing.

The establishment of a strong exit bank defense in each divisional sector is undertaken concurrently with the execution of delay operations. The defense of the exit bank must be as strong as possible with the available troops. The primary

mission of the defense is to overwatch the crossing of the forces remaining on the far side of the river.

Once defense forces are directed by the commander to assume responsibility for the battle, they are expected to defeat, or at least contain, the enemy in a specified area. This is essential for the successful completion of the crossing. As units engaged in delay operations negotiate the crossing, they are incorporated into the defense or are directed to prepare to assume the delay mission if further retrograde operations are warranted.

Because friendly forces control both banks of the river for some period prior to the operation, existing bridges and crossing sites should be continually improved and repaired. All available tactical bridging and rafting within the corps should be installed or prepositioned to the rear to supplement existing crossing means.

The activity begins with the actual crossings of CSS elements. These units evacuate all non-essential supplies and engage in prestocking the delay and defense forces. The crossing sites within the rear area should be fully operational early in the retrograde to allow elements not involved in the delay to cross the river at the

earliest possible time consistent with the tactical situation.

Operations within the retrograde crossing area are characterized by—

- Rapid and controlled flow of traffic across the river.
- Maximum use of concealment and dispersal.

Ž Coordinated crossing of equipment and supplies.

Ž Coordination between the defense and delay forces for use of crossing sites by the latter.

The difficulty of command, control, and coordination of retrograde crossings requires a clearly understood delineation of missions and tasks between the delaying, defending, and support forces.

Since the enemy has the maneuver initiative, it is essential to employ deception operations as an integral part of the plan. Deception should be planned and executed to deceive the enemy regarding the retrograde. The deception story should seek to conceal the location and extent of crossing operations.

FUTURE TECHNOLOGY, SHARPENING THE WARRIOR'S EDGE

This chapter provides a brief overview of the military application of existing and developing technologies. In general it looks out 5 to 10 years, and covers a range of equipment programmed for fielding, some still in development. These technologies will enhance the capabilities of the light force in both war and operations other than war.

The emphasis of technology developments for infantry forces are: command and control, sensing, lethality, survivability, and human performance and endurance. This application of science and technology is designed to help light forces operate more efficiently for longer periods of time, and in adverse climatic conditions. It will make them more lethal without significantly increasing soldier load. It will enable them to detect a threat at much greater distances during periods of limited visibility. Finally, it will help them to survive the more lethal, high technology battlefield of the future, and afford leaders a much clearer picture of the battlefield.

COMMAND AND CONTROL

The revised Army tactical command and control system (ATCCS) automation concepts will allow command and control from anywhere on the battlefield. Commanders must be able to see and understand the battlefield, communicate intent, issue orders, and synchronize the fight. ATCCS provides the commander a tool for managing large amounts of data and the ability to track both friendly and enemy status on a near real-time basis. ATCCS also provides the ability to prepare, coordinate, and disseminate plans, orders, graphics, and reports much faster than ever before.

Horizontal and vertical integration across all functional areas (maneuver, FS, AD, CSS, IEW) will provide for force level information, a common friendly picture, and automated OPORDs and overlays. This integration adds significant combat power to light forces by providing access to joint FS systems.

Global positioning sensors with single channel ground and airborne radio systems (SINCGARS) will include small automated display terminals at platoon, company, and battalion levels. This greatly enhances situational awareness, which in turn assists in battle synchronization and fratricide prevention. GPS with SINCGARS, integrated into maneuver control system electronic map capabilities, will provide the commander with near real-time disposition of friendly forces on an automated electronic map.

An automated smart handset will enable the SINCGARS user to dial directly into the MSE circuit switch.

Improved SINCGARS data capability, integrated with MSE packet network, provides common data distribution capability at all levels and a seamless data distribution architecture.

Integrated broadcast intelligence information services, with common communications and data processor that distributes information over packet network to MCS, will allow users to provide a common enemy picture, correlated intelligence, and a single source distributed enemy display.

The soldier's computer is a fully portable, lightweight, hands-free computer system designed for the individual soldier. This system will extend C³ down to the soldier level. Components of the computer include:

- Helmet-mounted display, which provides nearly the same image resolution as a desktop computer monitor.
- Pocket-sized computer.
- Hand-held input device, which works similar to a mouse or joystick and requires the use of only one thumb.
- Radio local area network (LAN), which can transmit voice or data bits.
- GPS, which permits the soldier to view a map depicting friendly, enemy, and his own position on the battlefield.

SENSING

The diffusion through a membrane (DITAM) apparatus will provide soldiers with a fast, easy-to-use hand-held device that is capable of detecting several hazardous substances, such as chemical warfare agents and fungal toxins simultaneously. Several of the devices will fit in the pocket of the BDU.

The individual soldier-operated personal acoustic detection system (ISOPADS) extends the soldier's useful listening range during patrols or perimeter defense operations. The ISOPADS has no electronics or batteries, has a highly directional capability, is passive (no emission signals), and can be hand held.

The fluorescent target detection (FTD) system uses a laser-induced fluorescence to detect ground-based military equipment, and has the potential for detecting chemical substances. The FTD system can detect chemical-contaminated surfaces, mines and explosives, and weapons and motorized equipment. The system can be either aircraft-mounted, vehicle-mounted, or carried by the soldier.

The biological and chemical agents detector, when fielded, will give the Army its first true biological detection capability, sensing a variety of toxins and pathogens as well as the traditional chemical agents. The detector will be man-portable, modular in design to incorporate new technology, battery-powered, and capable of displaying both the hazard class and an estimate of concentration.

LETHALITY

The multipurpose individual munition (MPIM) is an individual soldier weapon that will augment the M72 series and AT4 light antiarmor weapons. The weapon will be shoulder-fired and have the ability to defeat armored personnel carriers and incapacitate enemy personnel entrenched behind masonry structures and inside bunkers.

The Javelin is a man-portable antitank system designed to provide high lethality against conventional and reactive armor and will be a direct replacement for the Dragon. The Javelin uses "fire and forget" technology, which allows the gunner to fire and immediately take cover.

Additional special features are the top-attack or direct-fire mode, integrated day/night sight, dual warhead, and imaging infrared seeker. The target lock-on and soft launch feature allows the Javelin to be fired from enclosures and covered fighting positions. The Javelin is scheduled for fielding in July 95.

The family of fuzes for mortars replaces some 20 fuzes in the inventory. This three-fuze family for all mortars simplifies battlefield logistics, provides dual safety arming features, and reduces production costs through commonality of parts. The three fuzes are ballistically similar and form a complete family of fuzes usable with all mortar ammunition (60 millimeter, 81 millimeter, 120 millimeter, and 4.2 inch). The family consists of the M734 multioption fuze, M745 point-detonating fuze, and electronic time fuze.

Efforts continue to increase the lethality of small arms for the individual soldier on the battlefield. Projects include improvements to the M24 sniper weapon system, a 30-millimeter semi-automatic grenade launcher, and the M16A3 rifle with optical sights.

FIRE SUPPORT

There are two FS projects under development that could have a significant impact on light forces. They are the lightweight, towed, 155-millimeter howitzer and the high-mobility artillery rocket system (HIMARS).

The lightweight howitzer will replace, in part, the M198 howitzer. The system will have a crew no larger than the M198 and will be capable of low- and high-angle fire in all directions (6400 roils). The howitzer will be air-transportable and air-droppable from USAF aircraft and lifted by the CH47 helicopter. The weapon will fire all current and developmental 155-millimeter ammunition and will use a prime mover from the family of medium tactical vehicles (FMTV). The howitzer is programmed for production in FY 98.

The HIMARS answers the need for a lighter-weight, more deployable rocket and missile launcher that can be sent anywhere in the world to provide the maneuver commander lethal, long-range fires at the beginning of a conflict. The HIMARS will be transportable by C-130 and larger AF aircraft. It will fire the MLRS family of

munitions and have a maximum crew of three. It should enter production in FY 99.

SURVIVABILITY

In response to the proliferation of friendly and enemy lasers on the battlefield, the Army has developed eye protection for use in magnified optical devices. The M22 binoculars have been fitted with laser protection filter assemblies. Filters will also be installed in the optical sights of a number of weapons systems. These filters do not significantly reduce image clarity. Other technology may soon be available to counter modern lasers.

The ultra lightweight camouflage netting system is made with a close-knit fabric that is virtually snag-free as opposed to the current lightweight camouflage screening systems (LESS). A garnish material is sewn on top of the fabric to give it the appearance of natural vegetation. The garnish material has the same visual and radar properties as the current LESS. This system offers effectiveness equal to or better than the current system with approximately a 50 percent reduction in weight and volume, and a 40 percent reduction in installation time.

Security and force protection enhancement resources is an assembly of components designed to enhance personnel security. These components provide equipment for the detection, assessment, delay, and response to security threats. A combination of military and commercial components have been integrated into a system specially designed for operations other than war. Components include passive infrared, seismic, active infrared, and rapidly deployable detection sensors; razor tape concertina; low-light intensified cameras for remote assessment; NVDs for manual assessment of intrusions; and secure hand-held radios.

HUMAN PERFORMANCE AND ENDURANCE

The soldier system represents the effective integration of the individual soldier with material, operations, training, environment, and leadership. The system consists of all items or equipment worn, carried, or consumed in the field, and all controllable factors that affect how well a soldier performs his mission. The major

components of the system are food, clothing and protective equipment, shelters, weapons, and communications devices. Weapons and communications will be covered in separate sections.

Current emphasis is on developing combat clothing and individual equipment (CIE) which will improve the soldier's capability to counter emerging battlefield threats. Research and development is focused on the design of lighter weight equipment, ballistic and laser eye protection, and improved chemical protective clothing.

The Army has recently developed two training devices that will interface with the multiple integrated laser engagement system (MILES). They are a hand grenade and an M18A1 claymore mine. These devices are nonexplosive and provide visual and audible indications of action. These are very cost-effective devices that will enable soldiers to learn the casualty-producing effects and capabilities of these weapons.

Ongoing efforts to improve quality of life for soldiers include improved kitchen, laundry, shower, and other collective support equipment. Efforts also focus on items for the individual which will enhance quality of life in the field. Several items were provided to the troops in Southwest Asia which improved both their effectiveness and quality of life, such as flameless ration heater, improved operational ration items, and the five-soldier crew tent.

The soldier integrated protective ensemble (SIPE) is a modular fighting ensemble for the soldier, expected to be fielded by the year 2000. The SIPE will include an integrated helmet with individual communication system, weapons interface, ballistic and laser eye protection, respiratory and aural protection, and microclimate conditioning and power unit. The advanced clothing system will include uniform, body armor, handwear, footwear, and load carrying equipment. The SIPE will enable the soldier to communicate when out of earshot, shoot from the hip, and encapsulate for NBC operations. SIPE will provide protection from multiple battlefield hazards, including ballistic, flame, directed energy, and biological and chemical threats.

APPENDIX
**EXAMPLE TACTICAL STANDING OPERATING PROCEDURE
(TSOP)**

(Classification)

HEADQUARTERS

(Location)

(Date)

(Date)

DIVISION (____)

(_____) DIVISION (____) TACTICAL STANDING OPERATING PROCEDURE (TSOP)

Section I. GENERAL

A-1. Purpose. This TSOP prescribes guidance for the conduct of sustained tactical operations. Specifically, it standardizes those recurring operational routines, procedures, and responsibilities executed by both organic and supporting organizational elements throughout the division.

A-2. Application and Scope. This TSOP covers only wartime operations after deployment. It does not repeat doctrine, tactics, or techniques that are provided in FMs, technical manuals (TMs), and mission training plans (MTPs). It applies to all organic, assigned, attached, and OPCON units. It also applies to all supporting units operating in or occupying areas within the division's area. All TSOP provisions apply except as modified by operations orders and plans. No provision shall replace good judgment and common sense.

A-3. Directed Supporting Documents.

a. This TSOP and all subordinate TSOPs incorporate all current provisions of FMs, TMs, Army and division regulations, standardization agreements (STANAGs), joint agreements, and status of forces agreements.

b. Each division staff section will develop and implement standard tactical SOPs which will govern procedures for their functional area. Staff section tactical SOPs will conform to the procedures contained in this SOP.

c. Each MSC will publish a TSOP that supports and conforms to the division TSOP. The division chief of staff will approve MSC TSOPs.

A-4. Proponency. The division COB and MSC executive officers are the proponents for their respective TSOPs, Ensuring compliance with established tactical standing operating procedures throughout the division is a command responsibility which commanders and staffs at all levels must monitor.

A-5. Changes.

a. Changes are submitted through the appropriate coordinating staff officers to the CofS.

b. The CofS coordinates the changes.

c. The division commander is the approval authority.

Section II. COMMAND AND CONTROL PROCEDURES

This section prescribes operating procedures for command and control of the division. (This section is not all inclusive.) It establishes the basic guidelines for procedures and the operation of command posts. Subordinate units will develop their own internal command post SOPs to conform to guidance provided in this SOP.

A-6. Succession of Command.

a. Succession of command for the division is: CG, ADC-M, ADC-S, and CofS.

(1) The new commander notifies the next higher headquarters and all subordinate headquarters of the change of the division commander.

(2) Succession is automatic upon death, capture, or evacuation of the commander. The CofS should be notified as soon as possible to publish assumption of command orders.

b. Command of MSC units are assumed by the executive officer unless directed otherwise (for example, senior battalion commander).

A-7. Alternate Command Posts.

a. The division's alternate main command post is the aviation brigade main CP.

b. The alternate command post for the division's main CP is activated upon the following:

- The division main CP's surviving elements inform the command net of attack or destruction and the inability to function.
- A unit or element reports that the division's main CP has been destroyed and verification has been established.

c. If the main CP is destroyed or otherwise inoperable, the following units or organizations assume the functions listed below until the main CP is regenerated and operational.

<u>Main CP Function</u>	<u>Designated Alternative</u>
Command Center	Aviation Brigade
G3 Ops/Planning/ A ² C ²	Aviation Brigade
G2 Ops/ASPS	MI Battalion
FSE	DIVARTY
Engineer	Engineer Battalion Staff
ADA	ADA Battalion Staff
NBC Element	DISCOM NBC Section
ADSO	Signal Battalion

d. The TAC CP's alternate command post is the command group. Activation criteria are the same as in paragraph A-7b.

e. The rear CP alternate command post is the DISCOM CP, then the MSB command post.

A-8. Command Post Shift Cycles. All division and MSC command posts conduct staggered shift changes. Shifts of duty are 12 hours in duration. Change of shift briefs will not disrupt continuous performance of CP functions.

A-9. Displacement Operations.

a. Command post displacement for all division and MSCs is by echelon so that command and control of subordinate forces is uninterrupted.

b. Prior to movement, A and B echelons must have redundant capability to perform the functions of the CP.

A-10. Security.

a. Each command post is responsible for establishing its own security.

b. Off-shift personnel sleep in or near fighting positions surrounding the CP.

c. Fighting positions are designated 360° around the CP.

d. CP security elements, when used, establish a security zone 3 to 5 kilometers around the CP. The following operations are conducted to interdict enemy ground forces:

- Road checkpoints.
- Patrols.
- LPs and OPs.
- Employment of sensors.
- Employment of ground surveillance radars.

e. The CP operations NCO coordinates the employment of the security force.

f. Access to a command post is normally controlled by limiting access to one entrance and checking identification.

g. Additional security measures are implemented as the situation dictates.

A-11. Orders and Plans.

a. Unless otherwise stated, "Zulu" time is used in all division operations orders.

b. The ADC-M, ADC-S, CofS, and G3 have authority to issue warning orders in the CG's name.

c. The main CP G3 operations element provides sequential numbers for all division written orders. The S3 operations of all subordinate and supporting units issue orders numbers for their commands.

d. The ADC-M, ADC-S, CON, and G3 have the authority to approve and issue written FRAGOs in the CG's name. The TAC and rear CP should obtain an order number prior to issuing a written FRAGO from the main CP.

e. The following procedures apply for publication of orders.

(1) The G3 has overall responsibility for orders and plans.

(2) Staff sections review and sign annexes, if they are submitted for separate distribution. If they are distributed with the order, annexes are not signed.

(3) The division sends verbal FRAGOs by the most expeditious means available (followed by hard copy and overlay through couriers).

(4) The division uses the following guide for annexes:

- Annex A — Task Organization.
- Annex B — Intelligence.
- Annex C — Operations Overlay/Concept of Operations.
- Annex D — Engineer.
- Annex E — Army Aviation.
- Annex F — Fire Support.
- Annex G — Air Defense.
- Annex H — A²C².
- Annex I — Electronic Warfare.

- Annex J — Signal Operations.
- Annex K — Operations Security (OPSEC).
- Annex L — Deception.
- Annex M — Psychological Operations.
- Annex N — NBC Defense/Smoke Operations.
- Annex O — Military Police.
- Annex P — Rear Operations.
- Annex Q — Service Support.
- Annex R — Movement.
- Annex S — Civil Affairs.

f. Acknowledge receipt of operations orders to the issuing CP. Subordinate units submit one copy of all orders and overlays to division tactical operation center (TOC) G3 operations. MSCs and staff elements reproduce additional copies for internal use and distribution.

g. When the division is not committed to combat operations, the elements listed below receive copies of the OPLANs for the upcoming operations. This list is used only when there is sufficient time to reproduce and distribute a complete order. When the division is committed to combat operations, this listing will not be used.

<u>Copy Number</u>	<u>Addressee</u>	<u>Copy Number</u>	<u>Addressee</u>
1	CG	14	MI Bn
2	ADC-M	15	Signal Bn
3	ADC-S	16	MP Co
4	CofS	17	HQ Comdt
5	Bde	18	G1
6	Bde	19	G2
7	Bde	20	G3
8	DIVARTY	21	G4
9	Avn Bde	22	G5
10	DISCOM	23	PM
11	Recon Squadron	24	Corps HQ
12	ADA Bn	25-26	Attached Units
13	Engr Bn	31-35	Spares/Adjacent Units

h. The division uses FRAGOs and warning orders when it is committed to combat operations. Written copies go only to those commanders and staff officers with a requirement to know. (NOTE: To prevent fratricide, changes to scheme of maneuver and fires must be transmitted to all division units.

i. The proliferation and copying of orders is kept to *the absolute required minimum at all times*.

All orders and plans are identified by the type (such as OPOrd or FRAGO) and numbered sequentially from the beginning of the calendar year (OPOrd 15-93 is the fifteenth OPOrd issued in 1993).

(1) The CofS maintains a historical file of all orders (one copy) issued by the division HQ and those received from higher and adjacent HQ. All other copies remaining in the HQ are destroyed within five days after the complete execution of the base order.

(2) After issuance of the division order, any Army or corps level orders in the HQ are placed under the control of the CofS.

k. Phase lines from higher HQ are not renamed.

l. On division operations maps and orders, the division objectives (for the brigades) are used. The related corps objective (to the division) is shown in parentheses before or above the division-specified

objective. When necessary for clarity in verbal conversation, both names are used. Divisional brigades incorporate this procedure into their TSOPs. To ensure clarity, operational graphics are labeled as follows:

- (1) Objectives and engagement areas (people).
- (2) Division--explorers or Early American heroes:
 - 1st brigade—cartoon characters.
 - 2d brigade—presidents.
 - 3d brigade—Civil War generals.
 - Aviation brigade—World War H generals.
- (3) Areas of operation and assembly areas (places):
 - Division—cities.
 - 1st brigade—battles.
 - 2d brigade—colleges.
 - 3d brigade—states.
 - Aviation brigade—parks.
- (4) Routes/axis of advance (animals):
 - Division—big game.
 - 1st brigade—fish.
 - 2d brigade—farm animals.
 - 3d brigade—insects.
 - Aviation brigade—birds.
- (5) Phase lines and LZs and PZs (things):
 - Division—trees.
 - 1st brigade-cars.
 - 2d brigade—jewels
 - 3d brigade—weapons.
 - Aviation brigade—metals.
- (6) Routes (colors):
 - Division—red, white, and blue.
 - 1st brigade—black.
 - 2d brigade—purple.
 - 3d brigade—brown.
 - Aviation brigade—green.

m. The division's orders group assembles to receive or disseminate oral or written orders. Orders group members assemble by organic transportation at a location and time designated by the commander. The commander may call one of three different orders group compositions, depending on the situation.

<u>Orders Group A</u>	Orders Group B	Orders Group C
CG with cmd group	CG	CG
Bde CDRs	ADC-M	ADC-M
	ADC-S	ADC-S
	G3	CofS
	Bde CDRs	All MSC CDRs
	Avn Bde CDR	All primary staff
	Div Arty CDR	
	Recon Sqdn CDR	

The orders group designees normally do not bring subordinate commanders and staff to orders group locations. Temporary local security is provided by vehicle drivers.

Section III. STANDING OPERATING PROCEDURES

A-12. Task Organization. The following routine task organization of organic division elements represents the division's standard combined arms fighting organization for combat. This grouping applies until specifically changed by verbal or written OPORDs, FRAGOs, or warning orders. This task organization is the basis for all division movement, and tactical employment planning.

<p><u>1st Bde</u></p> <p>_____ Inf Bn _____ Inf Bn _____ Inf Bn _____ FA Bn (DS) _____ Engr Co (DS) _____ FSB (DS) _____ ADA Co _____ MI Tms</p>	<p>2d Bde</p> <p>_____ Inf Bn _____ Inf Bn _____ Inf Bn _____ FA Bn (DS) _____ Eng-r Co (DS) _____ FSB (DS) _____ ADA Co _____ MI Tms</p>	<p><u>3d Bde (Res)</u></p> <p>_____ Inf Bn _____ Inf Bn _____ Inf Bn _____ FA Bn (DS) _____ FSB (DS) _____ ADA Co _____ MI Tms</p>	
<p><u>Avn Bde</u></p> <p>_____ Atk Bn _____ Aslt Co _____ Aslt Co</p>	<p><u>DIVARTY</u></p> <p>_____ 155 Btry</p>	<p><u>DISCOM</u></p> <p>_____ MSB</p>	<p><u>DIV Troops</u></p> <p>_____ Recon Sqdn _____ Engr Bn(-) (Lt) _____ MI Bn _____ ADA Bn _____ Sig Bn _____ MP Co _____ Div Band</p>

A-13. Division Control Methods and Procedures.

a. Liaison Officer and NCO Procedures.

(1) Under the supervision of the chief of staff, the division employs three organic LO teams to provide nonreciprocal liaison functions from the division to the following units:

- Right adjacent unit.
- Main effort brigade.
- Higher headquarters.

(2) Allied and US Marine forces that are supporting or adjacent to the division exchange reciprocal LO teams. The division first provides the supporting effort brigade team, then the main effort brigade team.

(3) Administrative support is provided for LO teams or individuals by the receiving headquarters, to include:

- Accommodation and rations.
- Maintenance, fuel, and lubricants.

(4) Before departing the parent headquarters, the LO team—

- Obtains maps, call signs, overlays, and orders for upcoming operations.
- Understands the commander's intent.
- Gets current operations status from the operations center.
- Checks all staff sections for information to forward to higher or adjacent headquarters.

- Notes any task organization changes.
- Obtains written copies of FRAGOs, warning orders, CONPLANS, and OPLANS (when available).
- Gets phone numbers, secure fills, and radio frequencies.
- Notifies the chief of staff of the team's departure.

(5) On arrival at the receiving unit, the LO team—

- Reports to the receiving unit chief of staff or G3 and briefs them on the parent unit's current situation, status, location, and plans.
- Contacts the parent unit, informing it of the team's arrival (receive update if required).
- Reviews the receiving unit's situation and identifies problems.
- Exchanges information with each receiving unit staff section as required.
- Informs the chief of staff of the team's anticipated departure.
- Obtains required or available copies of FRAGOs, warning orders, CONPLANS, and OPLANS for subordinate units of the receiving headquarters.

(6) When returning to the parent unit, LOs brief the parent unit's chief of staff or XO on the following information pertaining to the supporting headquarter's status, including as a minimum—

- Upcoming operations and mission requirements for the supported unit (CONPLANS, OPLANS, and FRAGOs).
- The commander's intent for current and future operations.
- The current and projected priorities for CS and CSS.
- Changes in task organization and organization for combat.
- Updated unit locations.
- Any other specific information required by the parent unit commander.

b. *Standard Operational Brevity Code Words.* During all radio and wire communications, all units under division control use the following operational code words to shorten transmission time. (NOTE: Although secure equipment is available, the division must be able to operate under nonsecure conditions caused by equipment failure, compromise, and so forth.)

Bandits: Unit, vehicle, or enemy aircraft positively identified as enemy (observer gives direction to bandit).

“Bandits to the east”

Bingo: Switch to 2d alternate frequency.

Bogey: Unidentified aircraft (observer gives direction to bogey).

“Dynamite, dynamite, 2 bogies north”

Candles: Artificial illumination.

“Request candles, B71”

Chatter: Communications jamming.

“Chatter on my internal”

Cold: Area clean of enemy.

Disk: Zone or area reconnaissance.

“Execute disk, A14, B63, B41, A38”

Dump TIRS: Terrain index reference system (TIRS) has been compromised. Cease use until further notice.

Dynamite: Air defense warning that alerts the force of aircraft inbound or attacking NOW. Passed on the command net, used in connection with Bandit or Bogey. Requires immediate response.

Established: Unit has consolidated to position at the designated control measure.
"Established A21"

Fallout: Warning for arrival of radioactive fallout.

Fix: Send your location to me.
"Fix, out"
"Send me the location of _____"
"Fix T3J22, out"

Flash, flash: Clear the net immediately, critical traffic follows.

Gas: Chemical attack.

Geiger chase: Radiological survey or monitor.
"Geiger chase N21 to W33"

Geiger sour: Area monitored or surveyed is contaminated.

Geiger sweet: Area monitored or surveyed is not contaminated.
"From A21 to W33, geiger sour"
"D51 is geiger sweet"

Get: Put specific person designated by call sign on the radio.
"Get G26, out"

Guidons: Net call—subordinates answer to branch and unit sequence: Infantry, armor, artillery, engineer, by unit numeric designation; companies in letter sequence; and platoons in numeric sequence.

Hostile: A unit, vehicle, or aircraft positively identified as enemy.

Hot: Area occupied by enemy.

HUSH: Levels of signal security.
HUSH One: Free net
HUSH Two: Directed net
HUSH Three: Directed net with radio listening silence imposed

Jailbreak: Radio listening silence is lifted.

Klick: Refers to a kilometer; one klick equals one kilometer (one grid square on a 1:100,000 or 1:50,000 scale tactical map).

Long Run: Movement by alternate bounds.

Middleman: Radio relay.

Module: Field artillery standard ammunition package consisting of a battalion six improved conventional munitions (ICM).

Move or moving: The order to move or displace: acknowledgment that a unit is moving.

Nothing heard: Station called does not (or did not) answer.
"X79, this is T22, Nothing heard, out"

Orders: Oral orders to follow, prepare to copy, put the call sign principal on the radio (GET).

Plot: General enemy and friendly summary and commander's assessment; a quick and informal exchange of information between commanders and operations officers; not a formatted report.

Present: Call sign principal report to specified location
"F37 present at N26, 30 minutes"

Run-in: Code word used by moving unit during a rearward passage of lines to warn friendly units that it is "running" toward them and that enemy forces are pursuing it.

Set: Used during maneuver to indicate that the sender (bounding unit) has completed its bound and is prepared to overwatch from its present position. See Established (above).

Silence: Absolute radio silence imposed on all net users.
(Say 3 times)

Stand to: A time at which a unit has achieved a readiness condition in which it is fully prepared to fight. (Readiness condition (REDCON) One)

Switch: Change to alternate frequency. (Specify which frequency by frequency designation or the call sign of the commander of the frequency to be used.)
"Switch ALPHA JULIET" (Antijamming)
"Switch N5F32" (The unit frequency whose commander is N5F32)

c. Terrain Index Reference System.

(1) The division uses TIRS to provide a quick and accurate method to control the maneuver of units, pass out control measures, and prepare a change in mission FRAGO. It is used with checkpoints, phase lines, and other graphic control measures.

(2) The user pinpoints the location by shifting on a horizontal-vertical scale from the TIRS point to the locations.

(3) On secure radios, use TIRS in the clear. Example: "From Y17, Right 1.5, up .5." (The listener finds point Y17, then measures 1.5 kilometers to the right or east and .5 kilometers up or north to find the desired location.)

(4) On nonsecure radios, encode the numerical portion of the TIRS.

(5) TIRS is established from higher to lower. TIRS are designated by the G3 for both the current and future area of operations. Subordinate HQs may establish supplemental TIRS. TIRS is always alphanumeric. The first character is the only letter and is allocated as follows:

Div TAC/Main CPs	A	Avn Bde	O,P
Div Rear CP	B	Div Recon Sqdn	R
1st Bde	C,D,E,F	DIVARTY	S
2d Bde	G,H,I,J	Atchd/OPCON Units	T,U,V,W
3d Bde	K,L,M,N	Div Spares	X,Y,Z

(a) Do not use TIRS to request fires. Use only target numbers or grids.

(b) Subordinate division units use only TIRS that were established by division.

(6) If a TIRS map or overlay is lost, captured, or compromised, the responsible HQ reports the code words "Dump TIRS (*echelon code*)" to higher HQ. Full notification and reestablishment of a new TIRS is a command action. The echelon code indicates the highest level of TIRS that was compromised: DISTANT = division, BELOW = brigade, BASE = battalion, and CELLAR = company.

d. Division Recognition Techniques.

(1) **Combat Vehicle Marking System.** The division's combat, CS, and CSS vehicles are marked for rapid identification from the rear and sides. This facilitates control during battle by enabling quick and easy visual identification of units on the battlefield. Associating unit identification with vehicle markings assists in the reconstitution of forces and prevention of fratricide. This section prescribes standard symbols used to mark vehicles within the division. Marking of vehicles is accomplished within the following restrictions:

- Only standard chemical agent resistant coating (CARC) paint are used for marking (black and sand).

- Markings apply to all specified vehicles within the organization.

~ Markings consist of numbers and chevrons of the style and size described in this section and locations are standardized. Medical vehicles are marked IAW AR 750-1.

(2) **MSC Vehicle Markings.** Vehicles of the division MSCs are identified by a combination of a single half-chevron and a two-digit numeric identifier. MSC identifiers always begin with a zero and have a single half-chevron placed immediately adjacent and to the right of the numeric identifier. Division assigned MSC numeric identifiers are:

00\ Div HHC
 01\ 1st Bde
 02\ 2d Bde
 03\ 3d Bde
 04\ Avn Bde
 05\ DIVARTY
 06\ DISCOM

(3) **Unit Identifiers.** The following digits/symbols are assigned to units within the division:

<u>ID</u>	<u>Unit</u>	<u>ID</u>	<u>Unit</u>	<u>ID</u>	<u>Unit</u>
00\	Div HHC	03\	3d Bde	05\	DIVARTY
01\	1st Bde	7	_____ Inf	1	_____ FA
1	_____ Inf	8	_____ Inf	2	_____ FA
2	_____ Inf	9	_____ Inf	3	_____ FA
3	_____ Inf			4	155 Btry
02\	2d Bde	04\	Avn Bde		
4	_____ Inf	3	_____ Atk Bn	/3	_____ ADA Bn
5	_____ Inf	4	_____ Aslt Co	/1	_____ Engr Bn
6	_____ Inf	5	_____ Aslt Co	06\	DISCOM
				/6	MSB/FSBs
/7	_____ MP Co				
/2	_____ Recon Sqdn				
/4	_____ MI Bn				
/5	_____ Sig Bn				

(4) **Marking Size.** The size of the vehicle markings is shown below. The space between the numbers and half-chevrons is 2 inches. Side and rear markings are placed on doors or other flat surfaces and remain unobstructed by equipment, camouflage nets, or other miscellaneous items. Marking location and size may be adjusted to accommodate the type of vehicle.

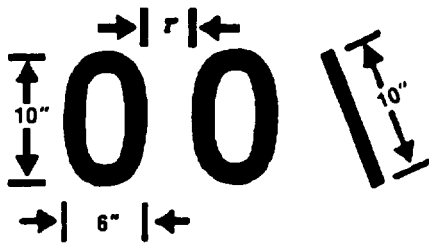

Dimensions of Side Markings

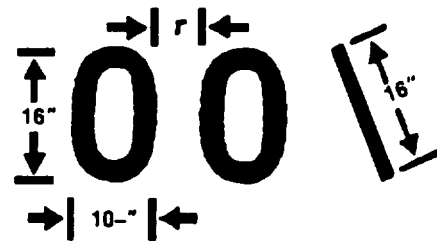

Dimensions of Rear Markings

(5) Separate Battalions/Squadrons and Companies. Vehicles assigned to divisional units are identified by a half-chevron and a two-digit numeric identifier combination. The first digit of the two-digit identifier designates the battalion/squadron and the second digit identifies subordinate company/troop/battery-sized units. The accompanying half-chevron identifies the vehicle as belonging to a divisional separate battalion/squadron or company. These half-chevron identifiers are placed immediately adjacent and to the left of the numeric identifiers. Divisional unit identification markings are as follows:

- /1 Engineer Battalion
- /2 Recon Squadron
- /3 ADA Battalion
- /4 MI Battalion
- /5 Signal Battalion
- /6 Division Main and Forward Support Battalions
(NOTE: /60 = MSB; /61 = 1st FSB; /62 = 2d FSB; /63 = 3d FSB)
- /7 MP Company

(6) Company/Troop/Battery Markings. Company, troop, and battery level units are assigned the following numbers:

- 0 HHC/HHT/HHB
- 1 A Co/Troop/Battery
- 2 B Co/Troop/Battery
- 3 C Co/Troop/Battery
- 4 D Co/Troop/Battery

(7) Platoon Markings. Platoons (or sections) are identified by the application of a single or double directional chevron. They are applied along with the battalion and company equivalent identifiers. Platoon identifiers are as follows:

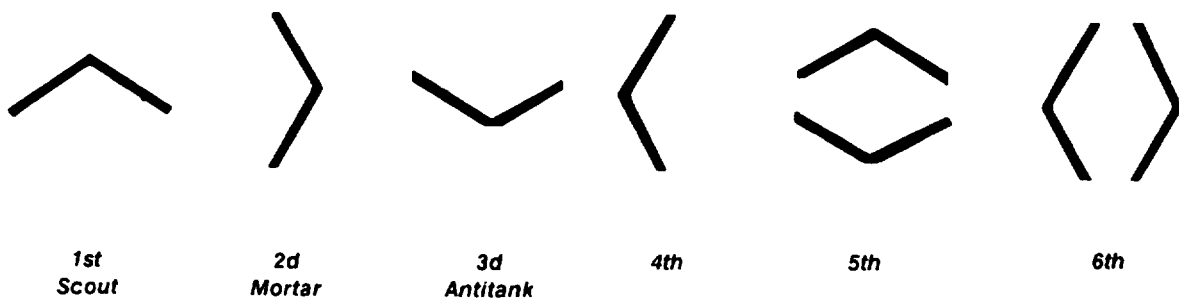

(8) Vehicle Top Markings. Each combat vehicle in proximity to CAS missions or when directed displays one VS17 panel on top of the vehicle. Panels are removed after the CAS missions if air superiority is not maintained. Chemical lights are placed on top of all vehicles for night recognition by friendly aircraft. Three lights are placed horizontally on any flat open surface, protected from observation by enemy forces.

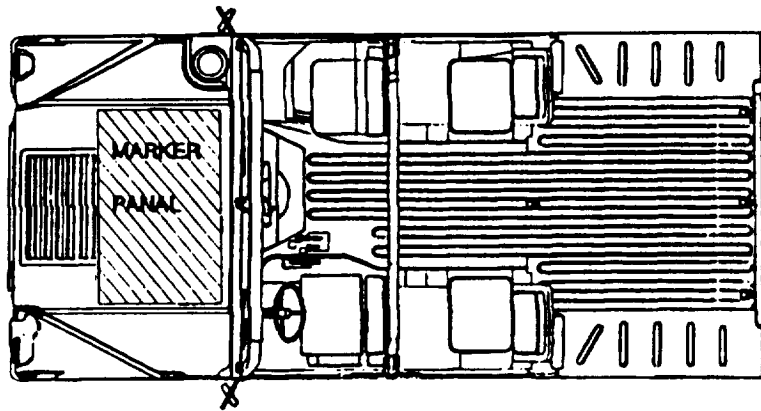

Marker Panel

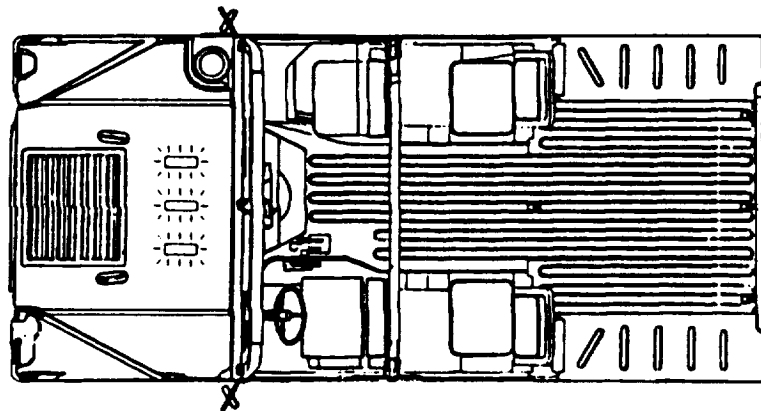

Chemical Lights

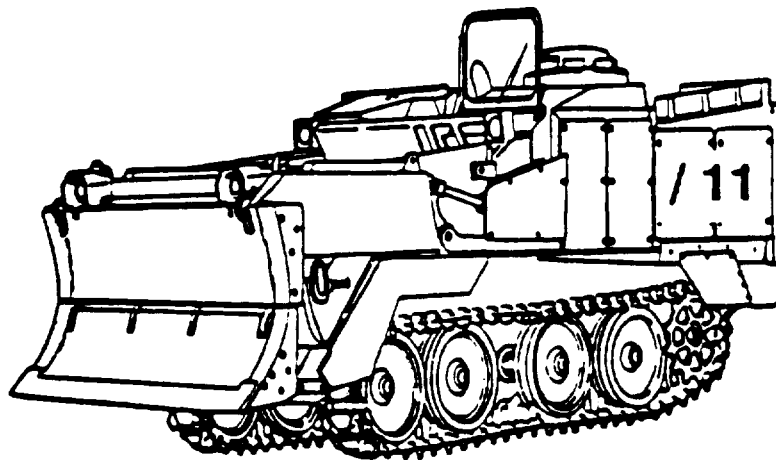
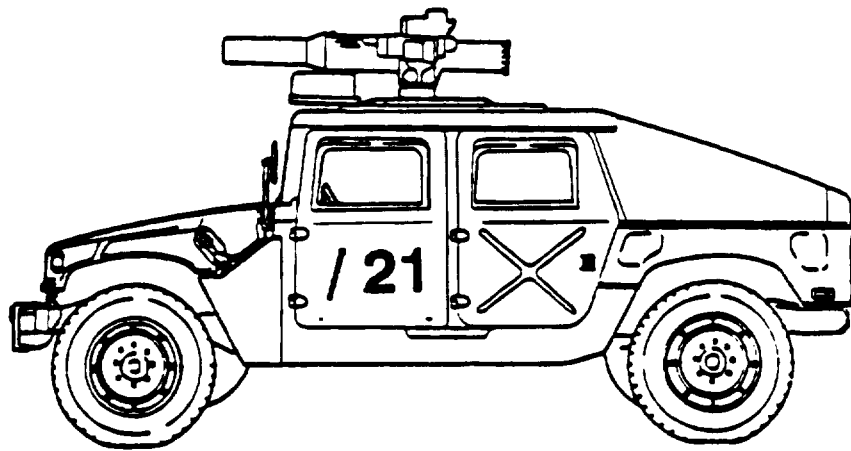
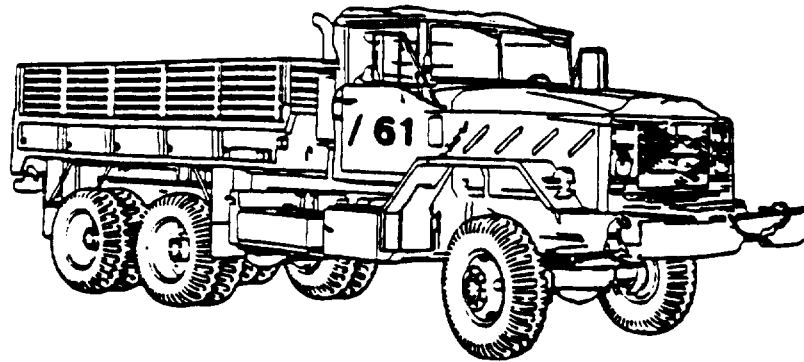

Examples of Vehicle Marking System

e. Signals. The following standard signals are established and used throughout the division to direct the indicated actions.

(1) Hand and Arm Signals, Tactical Formations.



COLUMN. Raise and extend the arm overhead. Move it to the right and left. Continue until the formation is executed.



STAGGERED COLUMN. Extend the arms so that upper arms are parallel to the ground and the forearms are perpendicular. Raise the arms so that they are fully extended above the head. Repeat.



TRAVELING. Extend the arm overhead and swing it in a circle from the shoulder.



TRAVELING OVERWATCH. Extend both arms and raise them up and down.

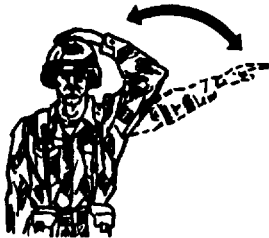

COVER MY MOVE. Extend one arm up to 45-degree angle. Bend the arm and tap the helmet. Repeat.



VEE. Raise the arms and extend them 45 degrees above the horizontal.



HERRINGBONE. Extend the arms parallel to ground. Bend the arms until the forearms are perpendicular. Repeat.



WEDGE. Extend the arms downward and to the sides at an angle of 45 degrees below the horizontal, palms to the front.



LINE. Extend the arms parallel to the ground.



COIL. Raise one arm above the head and rotate it in a small circle.



ECHELON LEFT. Extend the right arm and raise it 45 degrees above the shoulder. Extend the left arm 45 degrees below the horizontal and point toward the ground.



ECHELON RIGHT. Extend the left arm and raise it 45 degrees above the shoulder. Extend the right arm 45 degrees below the horizontal and point toward the ground.

(2) Hand and Arm Signals, Tactical Actions.



JOIN ME, FOLLOW ME, or COME FORWARD. Point toward person(s) or unit(s); beckon by holding the arm horizontally to the front, palm up, and motioning toward the body.

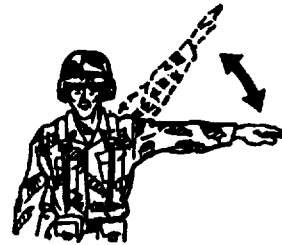

MOVE TO LEFT. Extend the arm to the left and raise it up and down.

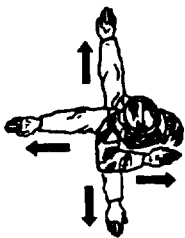

DISPERSE. Extend either arm vertically overhead; wave the arm and hand to the front, left, right, and rear, with the palm toward the direction of each movement.

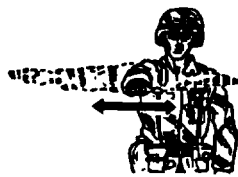

ASSEMBLE or RALLY. Raise the arm vertically overhead, palm to the front, and wave in large, horizontal circles. *NOTE:* Signal is normally followed by the signaler pointing to the assembly or rally site.



SLOW DOWN. Extend the arm horizontally sideward, palm to the front wave the arm slightly downward several times, keeping the arm straight. Do not move arm above horizontal.



INCREASE SPEED, DOUBLE TIME, OR RUSH. Raise the fist to the shoulder, thrust the fist upward to the full extent of the arm and back to the shoulder. Repeat rapidly.



CLOSE UP. Extend both arms parallel to the ground, palms uppermost, then move the arms upward and inward toward the head.



ADVANCE or MOVE OUT. Face the direction of movement; hold the arm extended to the rear; swing the arm overhead and forward in the direction of movement (hold at the horizontal), palm down.



FIX BAYONETS. Simulate the movement of the right hand in removing the bayonet from the scabbard and fixing it on the rifle.

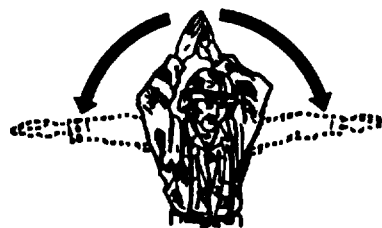

OPEN UP. Extend the arms overhead, palms inward, then slowly lower arms to a horizontal position.



ENEMY IN SIGHT. Hold the rifle in the ready position at shoulder level. Point the rifle in the direction of enemy.



TAKE COVER. Extend the arms at a 45-degree angle from the side, above the horizontal, palm down, and then lower the arm to the side.



HALT or STOP. Raise the hand upward to the full extent of the arm, palm to the front. Hold that position until the signal is understood.



AIR ATTACK. Bend the arms with forearms at a 45-degree angle. The forearms are crossed. Repeat.

(3) Hand and Arm Signals, Patrolling Actions.



MAP CHECK. Point at the palm of one hand with the index finger on the other hand.



PACE COUNT. Tap the heel of boot repeatedly with an open hand.



RADIOTELEPHONE OPERATOR FOR WARD. Raise the hand to the ear with the thumb and little finger extended.



HEAD COUNT. Tap the back of the helmet repeatedly with an open hand.



DANGER AREA. Draw the hand, palm down, across the neck in a throat-cutting motion from left to right.



FREEZE. Raise the fist to head level.

(4) Hand and Arm Signals, NBC Attack.



NUCLEAR BIOLOGICAL CHEMICAL ATTACK. Extend the arms and fists. Bend the arms to the shoulders. Repeat.

f. Alarms and Warning Procedures.

(1) The probability or likelihood of enemy attack or contact is signaled by warning color codes. These color codes apply to all combat action operations:

White: Attack or contact is not likely.

Yellow: Attack or contact is likely.

Red: Attack or contact is in progress or is imminent.

(2) Chemical attack is signaled by a continuous series of three short vehicle horn sounds, metal-on-metal, and electronic chemical alarms and the words "gas, gas, gas."

(3) Air attack is signaled by words "dynamite, dynamite, dynamite" with general direction. Continuous sounding of vehicle horn augments voice warnings.

(4) Indirect fires are signaled by words "incoming, incoming, incoming."

g. Threat Condition. Threat conditions in the division area of operations are developed by the G2 based on enemy capabilities, actions, sightings, and assessments of terrorist factors. THREATCONs dictate appropriate adjustments to security plans and manning level of CP or base defenses. Subordinate commanders may designate higher THREATCONs based on the local situation.

(1) The THREATCON is a two-digit warning which is passed laterally and vertically within the division's rear area to ensure receipt. The first digit is numeric (1-5) and is based on the overall threat while the second digit is alphabetic (A-D) and is based on terrorist assessments.

(2) The THREATCON is based on the enemy’s capabilities as shown by the intelligence preparation of the battlefield (IPB), the past and present actions of enemy forces in the rear area, and any sightings of threat forces in the rear area. A level of 1 indicates the lowest assessment of threat while 5 indicates the highest threat assessment:

- 1 Enemy capability
- 2 Enemy sightings in area
- 3 Enemy activity in area
- 4 Attack probable
- 5 Attack imminent

(3) In determining the threat condition, the assessment factors of existence, capability, history, trends, and targeting are considered.

(a) Alpha indicates a low assessment with existence and capability as factors.

(b) Bravo indicates a medium assessment, adding history or trends as a factor. Bravo is used when an increased and more predictable threat of terrorist activity exists.

(c) Charlie indicates a high assessment with existence, capability, trends, and targeting as factors. Targeting is not specific while history may be a factor. Charlie is used when an incident occurs or when intelligence indicates an imminent terrorist action.

(d) Delta indicates an imminent assessment with specific targeting a factor. Delta is normally used to localize warning to the specific target area.

Example: THREATCON 2C would indicate a generally low level of overall threat coupled with a high terrorist threat.

h. *Readiness Condition.* All division elements use the following readiness criteria in terms of time to state current readiness status, or to direct the attainment of a specific readiness status in anticipation of combat operations.

- REDCON One: I am fully ready to execute the assigned mission now and will initiate execution on receipt of orders.
- REDCON Two: I can be ready to execute an assigned mission in 15 minutes.
- REDCON Three: I can be ready to execute an assigned mission in 30 minutes.
- REDCON Four: I can be ready to execute an assigned mission in one hour.
- REDCON Five: I can be ready to execute an assigned mission in _____ hours. (Specify number if more than one hour).

i. *Example fixed Call Signs.* Upon enemy contact, the division communicates with the following fixed call signs using secure communications. The division uses nickname, historical phone directory, or call sign listing. Names listed here are examples only.

Div	BATTLE	Recon Sqdn	SCOUT
Div Aslt CP	BATTLE WHISKEY	DIVARTY	GUNNER
Div Main CP	BATTLE XRAY	DISCOM	MULE SKINNER
Div TAC CP	BATTLE YANKEE	Engr Bn	SAPPER
Div Rear CP	BATTLE ZULU	MI Bn	DAGGER
1st Bde	DRAGON	ADA Bn	SKY SWEEPER
2d Bde	BAYONET	Sig Bn	SPARKS
3d Bde	BULLDOG	MP Co	SHERIFF
Avn Bde	EAGLE		

<u>Element</u>	<u>Suffix</u>
Commander	6
ADC-M	63
ADC-S	64
CofS/XO	5
Deputy	Suffix + Bravo (for example, 3B)
C S M	7
G1/S1	1
G2/S2	2
G3/S3	3
G4/S4	4
G5/S5	8
Scout	29

<u>Element</u>	<u>Suffix</u>
FSE/FSCoord	30
CHEM/NBC	31
ALO/FLO	32
A ² C ²	33
ADE/Engineer	34
ADSO/Signal	9
PMO	35
IG	36
PAO	37
SJA	38
Chaplain	39

<u>Element</u>	<u>Suffix</u>
Surgeon	40
G3/AIR	3 ALPHA
LO	LIMA
Assault CP/Operations	WHISKEY
Main TOC/Operations	X-RAY
TAC/Operations	OSCAR

<u>Element</u>	<u>Suffix</u>
Rear/Operations	ZULU
NCS	NOVEMBER
Driver	DELTA
Pilot	PAPA
RTO	ROMEIO

Platoon Net Designations

1st Plt/Scouts	Red
2d Plt/Mortar	White
3d Plt/Support	Blue
4th Plt/Maintenance	Green
Antitank Plt	Gold
Communications Plt	Orange
Medical	Black

Platoon Member Designations

Plt Ldr	6
Plt Sgt	7
1st Sqd	1
2d Sqd	2
3d Sqd	3
4th Sqd	4

Company/Troop/Battery Prefixes

A Company/Troop/Battery	A
B Company/Troop/Battery	B
C Company/Troop/Battery	C
D Company/Troop/Battery	D
SVC Battery	E
HHC/HHT/HHB	F

Company Suffixes

CO	6
XO	5
1SG	7
1st Plt Ldr	16
2d Plt Ldr	26
3d Plt Ldr	36
AT Sec Ldr	46
Mortar Sec Ldr	56

Attached/Cross-Attached Suffixes

Armor	T
Mechanized	M
Engineer	E
GSR	R
ADA	A
Attack Helicopter	H

Note: If you are a tank company commander (C Company), cross-attached to a light infantry battalion, your call sign will be CT6. This avoids the confusion of having two C Companies in the net.

A-14. Tactical Road Movement.

a. *Responsibility.* All tactical road movement planning is the responsibility of the G3 operations, located at the division's main CP. The tactical CP controls tactical movements.

b. *Planning Factors for Mounted Movement.* (Planned for standard task organization.)

(1) Rate of March:

- All weather, hard surface roads, four-lane limited access—30 mph or 48 kph.
- All other roads—20 mph or 32 kph.
- Congested urban areas—12 mph or 20 kph.
- Blackout—10 mph or 16 kph.

(2) Intervals:

Ž Between vehicles: Daylight meters. During hours of darkness and within city or village limits—25 meters.

- Between march units: two minutes.

Ž Between serials: five minutes.

(3) Convoy Composition:

Ž Ten to twenty-four vehicles per march unit (maintain tactical integrity).

- Two to five march units per serial (maintain tactical integrity).
- Maximum five serials per convoy (maintain tactical integrity).

(4) Halts. Periodic rest and maintenance halts planned and conducted for 20 minutes after the first 2 hours; 10 minutes every 2 hours thereafter.

(5) Illumination. Vehicles in a convoy have their lights on low beam. Blackout driving is in effect forward of the light line.

(6) Convoys moving in the same direction pass one another only with permission from the tactical CP.

(7) Reports. MPs call in all convoy reports (lead vehicle crossing point) at start point (SP), TCPs, and release and other critical points within five minutes of unit crossing.

(8) Convoy Control:

• Prior to the division SP, two-person elements from the PM, DTO, DISCOM MCO, engineer battalion, and ADA battalion deploy forward to the TAC CP to help coordinate and adjust the movement plan as it is being executed. Once the movement is complete, these personnel return to their normal command post.

- MSCs are provided a block time for movement.
- Subordinate commanders appoint serial and march unit commanders.

Ž Disabled vehicles are left to the side of the route of march for pickup by trailing maintenance and recovery elements.

(9) Security. At least one alert air guard or observer is posted per vehicle during movement and weapons are oriented for 360-degree engagements.

c. *Planning Factors for Tactical Foot Marches.*

(1) Rate of March:

- Daytime on road—4 kph.
- Daytime cross country—2.4 kph.
- Limited visibility on road—3.2 kph.
- Limited visibility cross country—1.6 kph.

(2) Individual Soldier Load. The *maximum* load during approach marches is 72 lbs and the maximum individual fighting load is 48 lbs. Each company-sized unit has at a minimum one HMMWV with trailer for carrying supplies and equipment.

(3) March Formation. The division standard march formation is a staggered column of two's with one tile on each side of the road unless otherwise specified.

(4) Halts. A 15-minute halt is made after the first 45 minutes of marching. Afterwards, a 10-minute halt is made every 50 minutes,

(5) Length of March. Normally, the distance covered in a 24-hour period is from 20 to 30 kms marching from five to eight hours at a rate of 4 kph.

d. *Standard Orders of March for Tactical Movement.*

(1) The division conducts tactical movements on one, two, or three routes. The standard order of march for each route is as follows.

(a) One route of march:

Maneuver Brigade	MI Battalion
Main CP	Aviation Brigade
2d Brigade	ADA Battalion (-)
DIVARTY (-)	Signal Battalion
3d Brigade	MP Element
Engineer Battalion	DISCOM
Rear CP (LSA)	

(b) Two routes of march:

<u>Route A</u>	<u>Route B</u>
Maneuver Brigade	Maneuver Brigade
DIVARTY	Main CP
Engineer Battalion	Maneuver Brigade
Rear CP (LSA)	MI Battalion
Aviation Brigade	ADA Battalion (-)
Signal Battalion	MP Element
	DISCOM

(c) Three routes of march:

<u>Route A</u>	<u>Route B</u>	<u>Route C</u>
Maneuver Brigade	Maneuver Brigade	Maneuver Brigade
DIVARTY	Main CP	Engineer Battalion
MI Battalion	Aviation Brigade	ADA Battalion (-)
MP Element	Rear CP (LSA)	Signal Battalion
	DISCOM	DISCOM

(d) Standard orders of march are subject to redesign based on the nature of future operations and METT-T.

(2) Nondivisional units task-organized to support an organic division unit (DS, attached, OPCON, assigned) move with the supported unit. All others are inserted into the march order as the situation dictates.

e. *Route Priorities.*

(1) Movement of tactical units and unit displacement have priority over other moves. Other priorities are established as follows:

Priority

- 1 MEDEVAC
- 2 Combat unit
- 3 Combat support
- 4 Combat service support
- 5 CSS resupply moves in order of transportation priority
- 6 Combat moves to rear assembly areas
- 7 Combat support units moving rearward
- 8 CSS moves to rear
- 9 Infiltration moves (moves without clearance)

(2) The brigade's S4 denotes routes in the brigade's sector (except MSR) and reports their status through the FSB to the DISCOM MCO.

(3) The DTO, in coordination with the PMO, develops the highway regulation plan and the traffic circulation plan.

f. *Refugee and Host Nation Traffic Movements.*

(1) Refugee and host nation traffic is routed on secondary roads (other than MSR) when possible.

(2) Movements of HN traffic (10 or more vehicles or 100 or more personnel) must be coordinated with the DTO prior to movement.

(3) In concert with host nation's law enforcement personnel, division MPs assist, direct, and or deny movement of host nation traffic and refugees.

A-15. Assembly Area Occupation and Composition. (Also applies to occupation of attack positions.)

a. The division establishes two separate and distinct assembly areas within the corps' assigned division assembly area, a forward assembly area (FAA), and the division rear assembly area (RAA). They are normally 10 to 15 kilometers apart.

b. During the occupation of all assembly areas, 12 o'clock is always forward, and forward is the side nearest the enemy.

c. Units occupying the division RAA report to the rear command post. Other elements report to the G3 operations at the main CP.

d. The division occupies assembly areas in the following manner:

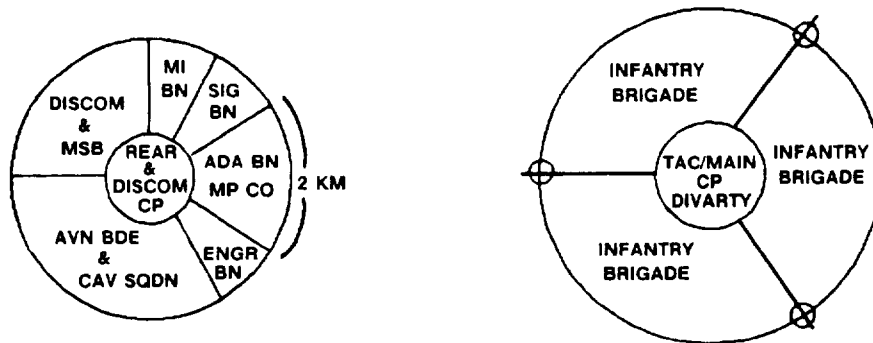

Corps assigned division assembly area.

- e. The division forward assembly area is occupied by the following elements:

TAC CP and Main CP (collocated)	Center Sector
1st Bde	9-12
2d Bde	12-3
3d Bde	3-6
DIVARTY/Recon Sqdn	6-9

A-16. Preparation for Combat.

- a. *Personal Combat Equipment Checks.*

(1) General Guide for Combat Uniforms. They must—

- Not break noise discipline.
- Not break light and camouflage discipline.
- Remain functional.

(2) General Rules:

- Tape or tie down everything that jingles or makes a sound during movement.
- Tape or blacken everything that is shiny.
- Button pockets to prevent items from getting lost, water or dirt from getting into pockets, and branches from snagging and ripping pockets.

ŽEnsure all personnel wear combat uniforms during tactical training missions, alerts, and combat missions.

- Use this SOP as a checklist.

(3) Boots:

- Have boots polished (not high gloss).
- Tuck excess laces into boots so that the laces do not catch roots or branches and the soldier does not trip over them.
- Blouse trousers into boots.

(4) Right Cargo Pocket. Carry all sensitive information—maps, notes, operation orders, communications-electronics operation instructions (SOIs)—in the right cargo pocket. If the soldier becomes a casualty, this sensitive information can be quickly removed.

(5) Ammo Pouches. Wear on the sides of the body to get lower in the prone position.

(6) Ammo Pouches (Magazines):

- Place loaded magazines upside down in the ammo pouches to prevent water and dirt from fouling the magazines.
- Place empty magazines right side up in ammo pouches. With empty magazines upright and loaded magazines upside down, you should be able to tell the difference between magazines without looking or, in the dark, by feeling them with one hand.

(7) Ammo Pouches (Grenades):

ŽAlways carry grenades in an appropriate container (for example, ammo pouches, grenade bag). Never carry them exposed and avoid placing grenades on the shoulder straps of load-carrying equipment (LCE).

- Do not carry smoke grenades on load-bearing equipment if you carry a rucksack. Keep them in your rucksack. Smoke grenades are not fighting grenades; under most circumstances there is time to draw them from the rucksack.

(8) Ammunition. Use a tracer-ball mix depending on the mission. (Leaders can use tracers to direct fire and aerial support.) If possible, when using a mix of tracer and ball, the last three rounds in each magazine should be tracer to remind the firer that he is nearly out of ammo.

(9) Rifle:

- Test-fire all weapons before the mission. After test-firing, do not tear weapons down again for cleaning or they will have to be test-fired again.
- Tape weapon swivels to prevent noise.
- Carry weapon-cleaning equipment on your person or in the butt of the rifle.
- Extract rounds in the chambers of weapons each morning and wipe them down because condensation (dew) may cause malfunctions.
- Check weapon and bore for any obstruction.
- Keep the reduced-visibility sight up during periods of darkness.

(10) Bayonet. Wear it on the prominent hand side of your body.

(11) Canteen:

- Before a mission, fill canteens completely to prevent water-sloshing sounds. Check for water purification tablets.
- Cover all broken NBC canteen caps with tape and have a pull tab on the tape to quickly remove it, even with gloved hands.
- Turn the loop made by the plastic piece connecting the cap to the canteen into the body to prevent branches from catching it.

(12) LBE Harness:

- Do not place anything bulky on the prominent side LCE shoulder strap that interferes with quickly getting the butt of your weapon comfortably into the pocket of your shoulder. This means that right-handed and left-handed soldiers have different LCE configurations.
- To cut down the number of entangling lanyards, secure more than one piece of equipment by the same lanyard. For example, the cord for pace-counting beads may also secure a whistle or compass or both.

(13) Compass:

- Secure by a lanyard anywhere comfortable and within easy reach.
- Ensure everyone issued a compass carries it.

(14) First Aid Pouch. Use the excess plastic at the opening of the first aid bandage to pull the bandage out of the pouch.

(15) Flashlight:

- Use colored filters on all flashlights forward of the division TAC CP.
- Connect the flashlight to the harness with a lanyard to prevent its loss.

(16) M258A1/M291 Decontamination Kit. Store in rear outside pocket of protective mask carrier.

(17) Protective Mask Carrier:

- Tape or blacken shiny parts.
- Tape down or remove mask ID tag to prevent noise.

(18) Sleeves. Wear sleeves down to protect and camouflage the arms.

(19) Dog Tags. Tape together to prevent noise. Use the standard Army issue breakaway chain.

(20) Face. Camouflage according to the colors and patterns of the area of operations and proper procedures for camouflaging.

(21) Helmet. Do not put anything on the chin strap that will interfere with the strap unsnapping.

(22) Protective Clothing Identification. For ease of identification, place a green strip of tape with abbreviated rank and last name printed in black over the right breast pocket flap and in the center of the back.

(23) Night Vision Devices (NVDS). Ensure NVDS are operational and have spare batteries.

b. *Personal Uniform and Equipment.*

(1) Worn:

- Battle dress uniforms (BDUs).
- Pistol belt with suspenders, two canteens, two ammunition pouches, first aid pouch, bayonet (diagram, page A-28).
- Ballistic helmet (Kevlar, see diagram on page A-29).
- Protective mask with M258A1 or M291 kit (training or M58 kit).
- Nerve agent antidote kit, Mark I, and CANA.
- Individual weapon.
- Field jacket and gloves (*).
- Wet weather parka and trousers (*).
- Overshoes (*).
- Protective clothing (as required by MOPP level) (*).
- Identification (ID) Card. ID tags around neck.
- M8 and M9 chemical detector paper.

(2) Rucksack (with individual soldier):

- One set of BDUs.
- Socks and underwear (minimum of two sets).
- Toilet articles.
- Entrenching tool (attached on side).
- Sleeping bag.
- One sleeping pad.
- Individual combat carrying equipment (ICCE) pack
- Two each MREs.
- Protective clothing.

(3) "A" bag (stored):

- Two sets of BDUs.
- Extra socks and underwear (minimum of three sets each).
- One pair of combat boots.
- One blanket, wool.
- Hood, cold weather.
- Parka, cold weather with liner.
- Scarf, wool (if not worn).
- One bag, barracks.
- One bag, waterproof.

*If not worn, items are packed in the "A" bag (duffle bag).

(4) Equipment. The diagrams below and on page A-29 show LBE equipment, helmet, and MOPP uniform.

c. Individual and Vehicle Checklists.

(1) Uniform:

- Protective mask.
- LCE complete.
- First aid packet complete.
- Ž Canteens full, with M17 drinking cap.
- Mask, with hood, M258 A1 or M291 kit in rear outside carrier pocket; Mark 1 kit convulsant antidote nerve agent (CANA), nerve agent pretreatment pyridostigmine (NAPP), and M8 or M9 paper in carrier.
- Helmet with camouflage cover and band.
- Individual weapon with magazines.
- Dog tags around neck, and ID card.

(2) Small-unit Leader:

- Map with current overlay.
- Current SOI.
- Ž Leader's packet, including:
 - Unit TSOP.
 - Markers.
 - Notebook.
 - Demonstration card.
 - EPW capture tags (DA Form 5976).
 - Call for fire card.
 - NBC warning and reporting (Graphic Training Aid (GTA) 3-6-3).
- Compass.
- Ž Binoculars
- Ž Dosimeter.

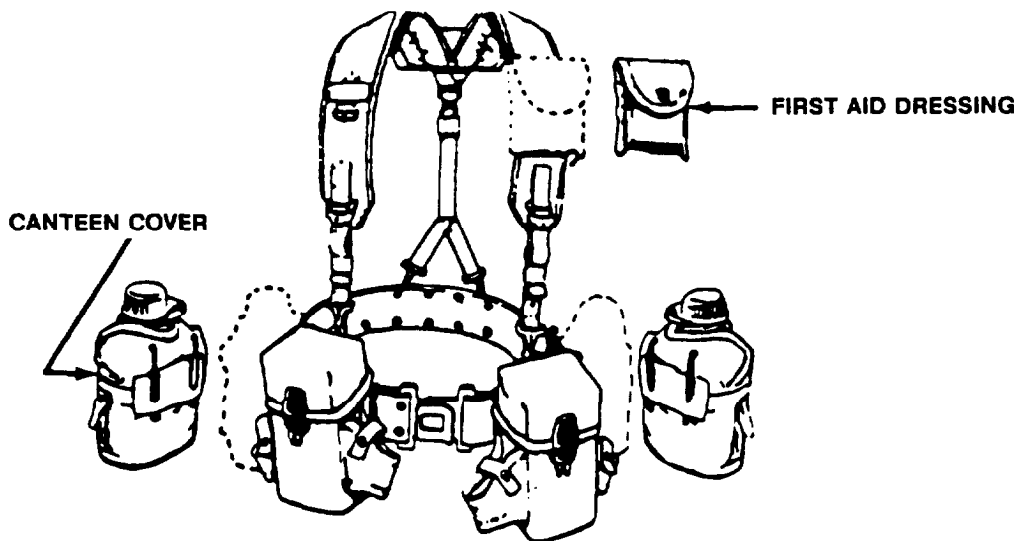

Individual uniform and equipment

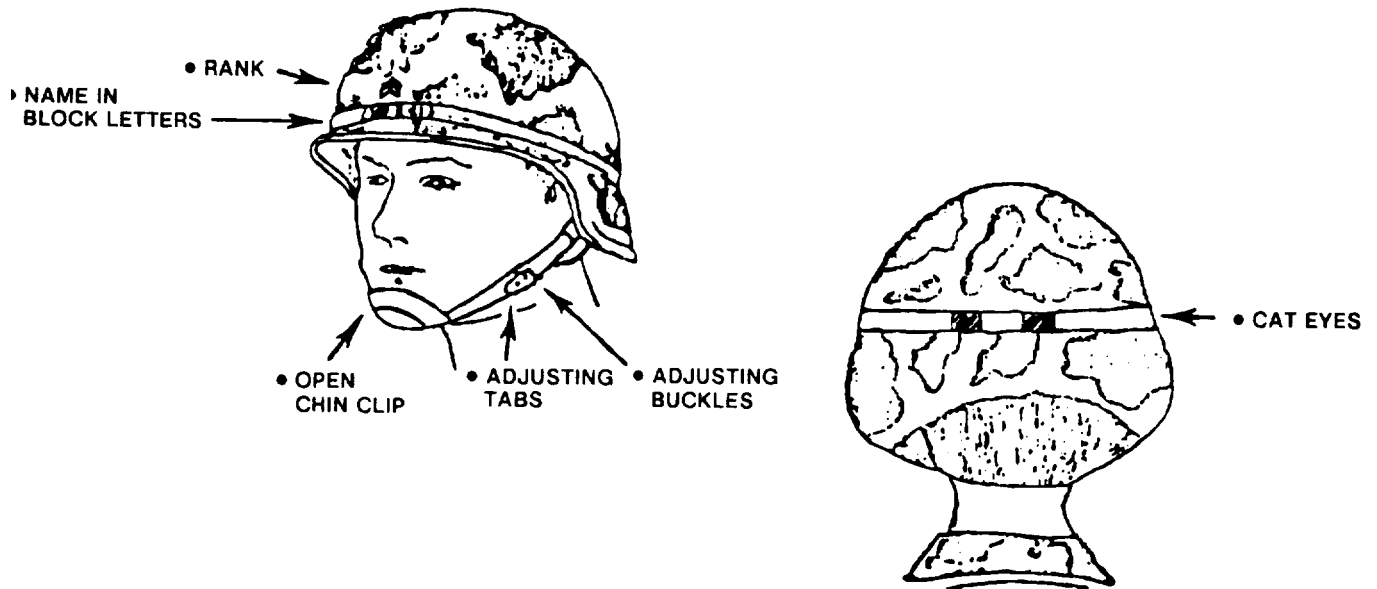

Helmet configuration

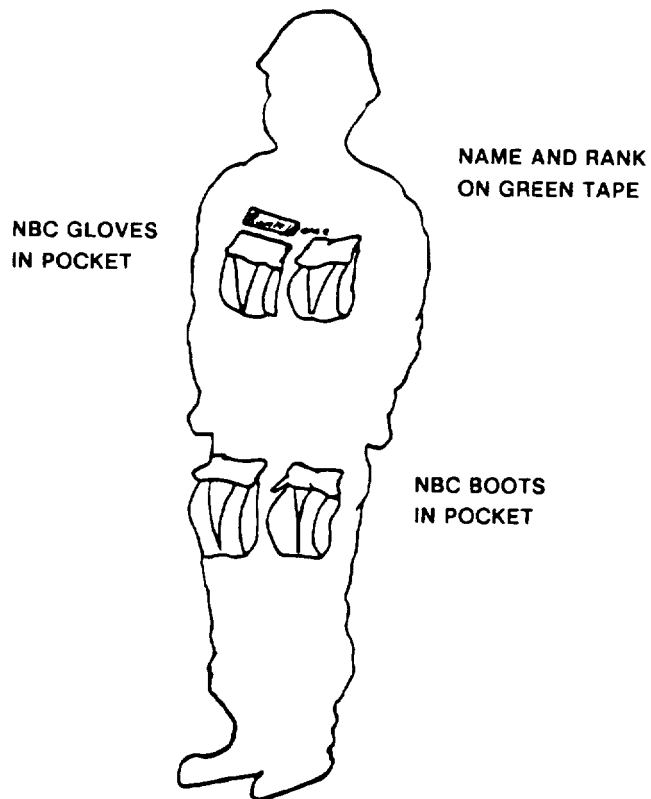

MOPP uniform

(3) *Vehicle Checks.*

(a) *General:*

- Loaded according to load plan.
- Topped off.
- POL package products plus weapons oil.
- Ž Water can full.
- MRE stowed.
- Weapons cleaning kits.
- Vehicle maintenance equipment stowed according to TM, and clean and serviceable.
- First aid kits complete,
- Ž Operator manuals on hand.
- Ž M11/M13 decontaminating apparatus (DAP) filled.
- M256A1 kit present.
- M9 paper present.

(b) *Automotive:*

- Preoperations check complete.
- No fuel leaks.
- Fire extinguishers sealed, tagged, and updated.
- Ž Fuel filters drained and checked.
- Ž Oil levels correct (engine and transmission).
- Ž Battery levels correct and cables secure.
- Air filters clean.
- Tires serviceable with correct tire pressure.
- Spare tire serviceable.
- Lights operational.
- Tire chains complete.
- Cooling system.
- Cold start system operational.
- No exhaust leaks.
- Interiors clean and orderly.
- All gauges functional.

(c) *Armament System:*

- Firing circuits operational.
- Sights clean, uncovered, and operational.
- Thermal imaging sight operational.
- Traversing and elevation system functional
- Ž Weapon's safety functional.
- Ž Ammo serviceable and stowed.
- Crew-served weapons:
 - Clean and functional.
 - Spare barrels, cleaning tools, bolts, and ruptured cartridge extractors present.
 - Headspace and timing set on M2 machine gun.
 - Machine guns properly mounted to include lock and pins.

- Binoculars.
- ŽCamouflage nets and supports.
- Compasses.
- ŽNight vision goggles with spare batteries.

(d) Communications Equipment:

- Radios:
 - Operational.
 - Secure and functional.
 - Proper frequencies set.
 - Matching units set.
 - Antennas tied down.
- Crypto variables present.
- Batteries present.
- TA312/TA-1 present with batteries and operational.
- SOIs complete.
- ŽAN/GRA-39 complete with batteries and WD-1 spools.
- TA1035 with WF16 operational.

(e) NBC Equipment:

- Protective clothing complete.
- Protective mask has the following accessories:
 - Helmet cover.
 - M258A1 or M291 decontamination kit.
 - M8 and M9 detector paper.
 - Anti fogging kit.
 - Hood.
 - NAPP tablets.
- ŽMask and hood serviceable with extra filters.
- Nerve agent antidote kit (NAAK) and CANA.
- ŽVehicles:
 - M11/M13 decontamination apparatus mounted.
 - Four 1-quart cans of DS2 issued per vehicle. Store in .50-caliber ammunition can (two DS2 per can).
 - M8A1 series automatic chemical agent alarm mounted and operational.
 - M229 series refill kit issued for each M8 alarm.
- ŽNBC defense equipment:
 - One complete and serviceable M256A1 chemical agent detector kit issued per platoon.
 - IM-174 series radiacmeters issued—one per platoon.
 - IM-931147 radiacmeters issued—two per platoon.
 - Two sets of batteries issued and serviceable for each IM174 series radiacmeter.
 - PP-157A radiac chargers issued (one per platoon).
 - NBC contamination markers present.

A-17. Other Tactical Operating Procedures.

a. *Link-up Operations.*

(1) Coordination Checklist (not in priority):

- Command relationship of units and the effective time.
- Enemy situation and obstacle plans.
- Mutual recognition system.
- Ž Communications plan.
- Schemes of maneuver and graphic control measures.
- Ž Fire support and fire support control measures.
- Primary and alternate link-up points.
- Ž Requirements for liaison exchange.
- Actions to be taken upon linkup.
- Ž Assistance required.
- Alternate plans if initial linkup fails.

(2) Assistance the stationary unit can normally provide:

- Guides.
- Ž Lanes through obstacles or airhead.
- Traffic control.
- Limited logistics, medical, and maintenance support.
- Ž Information on recent enemy activity.

(3) Assistance the moving unit can normally provide:

- Limited logistics, medical, and maintenance support.
- Fire support.

b. *Relief-in-Place Operation.*

(1) Coordination Checklist (not in priority):

- Ž Time for the relief.
- Routes, guides, link-up points.
- Assembly areas and positions to be occupied.
- Liaison, reconnaissance, advance parties.
- Ž Fire support coordination and control measures.
- Obstacle plans.
- Passage of command.
- Ž Call signs.
- Frequencies.
- Recognition signals.
- Ž The disposition of relieved unit supplies (POL, ammunition, rations) that the relieved unit

will not take with it.

- Reconnaissance and surveillance plan.

(2) Sequence of Events (for relief in contact and not in contact).

(a) On receipt of the corps warning order, procedures for tactical road movement go in effect. The division recon squadron conducts route reconnaissance from division's present location to the area of operations of the unit to be relieved. Makes initial linkup with unit being relieved.

(b) The division's tactical CP follows to collocate with the tactical CP of unit being relieved. It establishes link-up points for MSC coordination parties.

(c) *Passage of Command.* The incoming division commander assumes command of the sector and operational control of all nondivisional units within the sector at the established SP time for the relieving unit to begin moving from a rear assembly area to conduct the relief.

c. *Forward Passage of Lines* (applies only when enemy forces are not within direct or indirect fire range of the in-place unit).

(1) Coordination Checklist (not listed in priority):

- Time for the passage.
- Routes, guides, and link-up points.
- Assembly areas.
- Liaison, reconnaissance, and advance parties.
- Passage corridor SP and RPs through in-place unit.
- Fire support (direct and indirect).
- Obstacle locations and lanes.
- Passage of command.
- Call signs.
- Frequencies.
- Recognition signals.
- ADA coverage and weapons control status.

(2) *Sequence of Events.* The tactical CP moves to collocate with the tactical CP of unit being passed through and establishes link-up points for brigade coordination parties and begins coordination.

(3) *Passage of Command.* The passing division assumes tactical control (TACON) of the unit it passes at the established SP for movement out of a rear assembly area to begin the passage.

d. *Rearward Passage of Lines.*

(1) *Sequence of Events.* The recon squadron coordinates the following:

- Location of in-place units and obstacles throughout the in-place unit's area.
- Tactical disposition of passing unit.
- Location of the battle hand-over line.
- Location of rear assembly area, and routes out of rear assembly area (if not provided by corps).
- Passage lanes and passage points to support the scheme of maneuver.
- The contact point for each passage lane and guide requirements.
- Routes to each contact point.
- The route from each passage lane to the rear assembly area.
- Detailed locations of units and obstacles.
- Locations of rally points.
- Combat service support responsibilities.
- Arrangements for additional reconnaissance.

(2) *Passage of Command.* Tactical control of the passing unit passes to the stationary unit at a designated time established by higher headquarters or at a time coordinated between the two units.

(3) *Sequence of Passage:*

- Rear command post with MP company.
- DISCOM.
- Main command post.
- Engineer battalion.
- ADA battalion.

- MI battalion.
- Aviation brigade.
- DIVARTY.
- Reserve (if not committed).
- Supporting effort brigade with attachments.
- Tactical CP.
- Command group.
- Main effort brigade.

(4) Isolated or Cut-off Units or Individuals. Units or individuals that are isolated, cut off, or forced to conduct passage of lines through an area or unit other than as previously coordinated use the following procedures:

ŽAttempt radio contact.

•Establish contact with the stationary unit using challenge, password, and recognition signals in SOIs.

ŽConduct passage as situation dictates.

(5) Hasty Passage (Run-in). Run-in is used when the enemy's actions prevent the execution of a previously coordinated passage.

(a) The run-in unit disengages and moves to rally points to prepare for passage.

(b) On the radio, the run-in unit provides—

- Complete call sign.

- Prowords "run-in, run-in."

ŽNumber of personnel and vehicles in the passing element (in the clear).

ŽTransmission authentication. (Sample run-in message: "This is W7N36, run-in, run-in, twelve/one, I authenticate DELTA, FOXTROT.")

(c) Retransmit the above data until receiving a reply or completing passage.

(d) The moving unit stays on clearly defined routes; it conducts run-ins with vehicles' headlights on, weapons oriented toward enemy, and vehicle recognition signs facing friendly units.

e. *River Crossing Operations.*

(1) Crossing Force Headquarters (CFHQ):

- Location: Division TAC CP. When available a corps' engineer group CP collocates with the division's tactical CP.

- Crossing force commander: ADC-S.

- Crossing force engineer: Senior engineer element commander.

(2) Crossing Area Headquarters:

- Crossing area commander: brigade XO.

- Crossing area engineer senior engineer supporting the brigade.

A-18. Air Defense Artillery (ADA) Procedures.

a. *Air Defense Warning (ADW).*

(1) ADW RED: attack imminent or in progress.

(2) ADW YELLOW: attack probable.

(3) ADW WHITE: attack not likely.

b. *Weapons Control Status (WCS).*

- (1) WEAPONS FREE: Fire at any aircraft not positively identified as friendly.
- (2) WEAPONS TIGHT: Only fire at aircraft positively identified as hostile. (Any ADA unit losing communication with higher ADA HQ will assume weapons hold status.)
- (3) WEAPONS HOLD: Do not engage except in self-defense.

c. *Hostile Criteria.* An aircraft is considered hostile when—

- (1) It is visually identified as an enemy.
- (2) It attacks friendly forces or facilities by—
 - Discharging smoke or spray.
 - Air-dropping soldiers without prior coordination.
- (3) It maneuvers to attack friendly forces or facilities.
- (4) It meets any additional hostile criteria published in OPLANs or OPORDs.

d. *Rules of Engagement.*

- (1) Division is not Committed. Division ADA weapons are restricted to self-defense engagements only.
- (2) Division is Committed. Division rules of engagement will be established. Commanders may establish a more restrictive weapons control status for engaging in the sector. However, they may not impose a less restrictive status. Small arms for air defense will be controlled and operated under weapons tight status.

e. *Early Warning System.*

- (1) The division ADA early warning system is the manual SHORAD control system (MSCS).
- (2) Early warning is broadcast on unit command nets and on the division's air defense early warning net.
- (3) The division ABMOC uses the SHORAD grid matrix (page A-36) to transmit hostile aircraft information.
- (4) The center point of this grid matrix is published in the division OPLAN or OPORD.

Example: (See SHORAD grid matrix.)

- You are located in Kentucky.
- The ABMOC transmits: "Track ###, hostile, Lewis-5-5, northwest, few, helicopter."
- You know that two to four enemy helicopters are headed towards you and are about 20 kilometers away.

IGOR	HAWAII	INDIAN	JAMICA	KERATE	LASER	MAPLE	NELSON
LOSON	HATRET	INFANTRY	JAMES	KENNYOT	LAVA	MADE	NEON
LINGER	HAWAII	INSEANO	JAPAN	KENOTHA	LESION	MATRIE	NEPTUNE
GLACIER	HAWA	INSECT	JASPER	KENTWAY	LEMON	MESIC	NEUTRON
GOLD	HAZEL	INVASER	JAVELIN	MILDGAB	LEOPARD	MERLUPE	NEVADA
LEADON	HEMLOCK	IOWA	JELLO	KING	LEWIS	METESA	NIAGRA
GRILLA	HENRY	IRISH	JERSEY	KIOWA	LICORICE	MERICO	NICHOLAS
GRANITE	HICKORY	IRON	JESSICA	KIWI	LILAC	MIAMI	NILE
GRANTY	HOLLY	IRQUOIS	JEWEL	KLOWDING	LIME	MIDAS	NITRO
GRAY	HOOD	ISRAEL	JOCRET	KHANN	LINCOLN	MUNT	TOMAS

SHORAD grid matrix

Track format gives:

- ID (hostile, unknown, or friendly).
- Location (in 10-kilometer grid plus 1-kilometer grid increments, read right and up).
- Heading.
- Raid size-one, few (two to four) or many.
- Aircraft type (jet, prop, or helicopter).

A-19. A²C² Operating Procedures.

a. The division's A²C² element in the main CP is the division's authority for deconfliction of airspace to support current and future operations.

b. Subordinate commanders must coordinate with the division's A²C² element.

c. Brigades are responsible for coordinating air routes and air axis to firing positions which provide minimal conflict with indirect fire weapons.

d. **A²C² Control Measures.** Effective date-time groups (DTGs) will be annotated within each plotted control measure.

(1) Low-level transit route (LLTR).

(2) Air control point (ACP).

(3) Standard use Army aircraft flight route (SAAFR), SAAFRs are used to control division organic and supporting rotary wing transiting through the division and corps rear area. SAAFRs are defined by interconnecting ACPs of 2-kilometer width. They extend from ground level to 500 feet above ground level (AGL).

(4) Air Axis. Air axes are used for maneuvering through brigade boundaries. Air axes are defined by interconnecting ACPs of 4-kilometer width. They extend from ground level to 100 feet AGL.

(5) Restricted operations zone (ROZ).

(6) Weapons free zone (WFZ).

(7) High-density airspace control zone (HIDACZ).

(8) Identification, friend or foe (IFF). Switch-off and switch-on lines will be coordinated and distributed by the A²C² cell.

e. *Airspace Control Orders (ACOs) Dissemination.*

(1) Dissemination Cycle.

<u>Dissemination Time</u>	<u>Valid Period</u>	<u>Number (10 OCT)</u>
2400Z	0300-1059Z	10
0800Z	1100-1859Z	10A
1600Z	1900-0259Z	10B

(2) Division ACO. A²C² control measures are disseminated by ACOs as shown below.

Precedence.

ACO No.

Valid from _____ to _____ .

Section A. Additions or changes to ACPs.

Section B. SAAFRs.

Section C. Air axes.

Section D. LLTRs.

Section E. Coordination altitude.

Section F. Minimum risk routes (MRRs).

Section G. ROZs.

Section H. Weapons free zones (WFZs).

Section I. HIDACZs.

Section J. IFF switch off and IFF switch-on line.

Section K. Weapons control status (WCS).

Section L. Remarks or additional control measures.

A-20. Signal Procedures.

a. Operations.

(1) Call signs and frequencies change daily at 1200 hours (local time), unless in contact with enemy forces. Call signs and frequencies will not change when any brigade-sized element is engaged with enemy forces.

(2) CP's priorities for signal support and installation are:

- CNR.
- ŽTACSAT.
- MSRT.
- ŽMSE phones, fax, and CT.
- MCS.
- ŽTACFIRE.

b. Supported Unit's Responsibility.

(1) Coordinate with the signal battalion on procedures to pick up its signal support teams.

(2) Provide logistics to signal support team.

(3) Include the signal team chief on all new site reconnaissance and planning meetings. Provide the signal team chief advance notice prior to relocation to accomplish coordination with the signal battalion.

c. Signal Support Team Responsibility.

(1) Install, operate, and maintain multichannel and TACSAT.

(2) Coordinate signal support requirements with the unit's signal officer.

d. Mobile Subscriber Equipment.

(1) The division COMSEC office of record (DCOR) will distribute U and M keys MSRT and U key MCS to unit brigade signal officers.

(2) Keys will be tagged as follows:

U110X (on the KYK-13 or KYK-15)

U= Key Tape

110 = HUS Location

X = Edition

(3) Keys will change over on the last day of each month at 1200 hours.

(4) The frequency plan for MSRTs will be downloaded from a radio access unit (RAU) at location and time directed by the signal battalion.

(5) Each command post and staff section is responsible for the installation of its section's MSE equipment. Sections lay their MSE wire or cable up to the supporting signal unit junction box and hook up and tag the wire at both ends with subscriber information (section number, subscriber listing, J-box number, and pair number).

(6) MSE Support Allocation:

<u>Unit/CP</u>	<u>SEN</u>	<u>LEN</u>
TAC	2	
Main	2	

Unit/CP	<u>SEN</u>	<u>LEN</u>
Rear		1
Maneuver Bde Rear	2	
DIVARTY	2	
Avn Bde	1	
MI Bn	1	
ADA Bn	1	
Engr Bn	1	

e. *Combat Net Radios.* All radios will be operated in the secure mode. While in the secure mode, fixed call signs may be used, If it is necessary to operate in a nonsecure mode, only call signs or suffixes contained in SOI will be used.

f. *FM Communications.*

(1) Primary FM nets:

• *Command:* for commanders only.

• *Operations net:* for commanders, G3s, and S3s only. G3 operations at the main CP is the NCS.

• *Intelligence net:* for intelligence gathering. G2 operations at the main CP is NCS.

• *Rear operations net:* for G2, G3, FSE, TCF, and MP. NCS is the operations cell in the division rear CP.

• *Administrative/logistic net* for G1 and G4 operations. The CSS cell at the division rear CP is NCS.

(2) Vinson Guidance.

(a) Vinson is used by the NCS to distribute variables over the FM radio.

(b) Units and staffs will coordinate with their signal support element to ensure their MX-10579 or other electronic counter-countermeasures (ECCM) fill devices are marked and loaded with the correct variables before operation. Information concerning net descriptions, call signs or suffix, frequencies, signs and counter signs, smoke and pyrotechnics, frequency hopping, variables, and supersession information is contained in basic generator unit (BGU) or electronic notebook (EN).

(c) Division command and operations nets use division-wide transmission encryption key (TEK) and key encryption key (KEK).

(d) Subordinate units use unique Vinson—TEK fills. All FM nets internal to that respective unit use the TEK in Vinson fill position two.

(e) Organic division units cross-attached within the division receive new parent units TEK via manual-remote keying (MK). Subordinate elements receive these variables via MK or automatic-remote keying (AK) operations.

(f) Units not assigned to the division coordinate with the ADSO or their new parent unit for issue of TEKs and KEKs.

(3) Generation of Cryptovariables. The signal battalion is responsible to ensure that cryptovariables are generated and distributed to all major subordinate commands and separate battalions in the division.

(4) Division Variable Storage:

- Fill position one: division command net TEK.
- Fill position two: all battalion command nets TEK.
- Fill position three: all brigade command nets TEK.
- Fill position four: the corps command net TEK.

- Fill position five: currently assigned for permanent use.
- Fill position six: the division rekeying variable (RKV) storage.

(5) Variable Changeover:

• All CNVs will be changed every Friday at 1500 hours local time. Whenever possible, all CNVs will be changed physically using a KYK-13/KYX-15. MK operations will be performed only when absolutely necessary.

- The division RKV will be changed manually.
- Units will use their specific variable on their internal nets.

(6) All non-SINCGARS radios will operate “new squelch on.”

(7) Retransmission or relay priority is to—

- Unit command net.
- Unit operations net.
- Unit intelligence net.
- Unit administrative or logistics net.

g. *Radio Teletype (RATT).*

(1) TSEC/KB-84A is set at 150 words per minute.

(2) Upon deployment, MSCs enter GP NET using organic RATTs until arrival of supporting signal battalion’s RATTs.

(3) Place RATT stations no closer than 200 meters from the command post.

h. *AM Voice Operation (long-range command net).*

Activate only on order of the division’s main CP TOC or the division’s TAC CP.

i. *Courier.*

(1) The signal battalion schedules and resources daily courier operations.

(2) The courier route from division TOC includes the division TAC CP and rear CP, the MSCs, all separate battalions, and all units attached or OPCON.

(3) The signal battalion and the tactical situation determine the courier schedule.

(4) The signal battalion coordinates air courier operations directly with the aviation brigade operations.

(5) Commanders, staff officers, and LOs traveling between CPs will also act as couriers if required.

j. Wire. Priority of wire installation is as follows:

- Main command post—G3 operations element, command center, G2 operations, and others.
- Division TAC CP-G3 operations cell, intelligence, FSE, and engineer-chemical cell.

k. *Tactical CP Radio Nets.*

<u>Element</u>	<u>Priority Nets</u>	<u>Element</u>	<u>Priority Nets</u>
ADC-M	Div Cmd Net Corps Cmd Net	G2	Div Intel Corps Intel
G3	Div Cmd Corps Cmd	FSE	DIVARTY Cmd Fire Direction 1

l. *Command Group Radio Nets.*

<u>Element</u>	<u>Priority Nets</u>
CG HMMWV	Div Cmd Corps Cmd

m. *Main CP Radio Nets.*

<u>Element</u>	<u>Priority Nets</u>	<u>Element</u>	<u>Priority Nets</u>
Cmd Ctr	Div Cmd Corps Cmd	FSE	DIVARTY Cmd Fire Direction 1 Div Ops
G3 Ops	Div Cmd Corps Ops	A ² C ²	Avn Bde Cmd ADA Bn Ops AD Coord
G3 Plans	Div Cmd Bde Ops	NBC	Div Ops
ADSO	Sig Bn Ops	Div WX	Div Intel Avn Bde Weather Net AF Weather Net
ASIC	Div Intel MI Bn Ops		
G2 Ops	Div Intel Corps Intel		

n. *Rear CP Radio Nets.*

<u>Element</u>	<u>Priority Nets</u>	<u>Element</u>	<u>Priority Nets</u>
ADC-S	Div Cmd DISCOM Cmd	G1/G4/DTO	Div A/L DISCOM A/L Div Cmd COSCOM Ops
ADSO	Sig Bn Ops	PMO	MP Ops
G2/G3/FSE	Rear Ops Div Cmd Div Rear Intel Fire Direction 1	G5	Rear Ops

A-21. Intelligence and Security Procedures.

a. *General Security Procedures.*

(1) Sweep evacuated command posts, buildings, bivouac areas, and assembly areas to ensure no classified or sensitive material is left behind.

(2) Guard classified equipment and material (such as overlays, documents, vehicles) 24 hours daily when they cannot be secured.

b. *NAI and TAI Designation Procedures.* Division NAI designations are controlled and maintained by the G2 or S2.

<u>Origin</u>	<u>Description</u>
Division	Numeric only (1—30)
(TAC, main, rear)	
1st Bde	Begin with A (A1, A2)
2d Bde	" " B "

<u>Origin</u>	<u>Description</u>
3d Bde	Begin with C (C1, C2)
Avn Bde	" " H "
Recon Sqdn	" " V "
DIVARTY	" " F "
Engr Bn	" " E "
DISCOM	" " D "
MI Bn	" " M "
ADA Bn	" " Z "

c. *Document Security.*

(1) Do not carry or distribute written classified tactical orders forward a battalion CP. Top secret material will always be under armed guard and in the possession of an individual with a top secret clearance.

(2) Remove classified material immediately from personnel wounded or killed in action to prevent its capture or compromise.

(3) Do not permit classified material, except SOIs, to be carried in aircraft flying over enemy lines.

(4) Emergency Destruction of Classified Material.

(a) Personnel carrying classified material will be prepared to destroy that material in the event of imminent capture. The senior leader present will make the decision to destroy it.

(b) Each CP vehicle will have thermite grenades in a readily available and marked location. Every member of the CP will be familiar with destruction plans and how to use the thermite grenades.

(5) Actions on Loss or Compromise of a Classified Document.

(a) Conduct an immediate, thorough search if a document is missing.

(b) Inform higher headquarters by fastest secure means if information which impacts on tactical operations has or may have been compromised. Precedent is immediate.

d. *Personnel Security.* Commanders report absent without leave (AWOL) personnel who have access to classified information to G2 at the division's main CP.

e. *Counterespionage, Countersabotage, Countersubversion, and Disaffection.*

(1) Report all known or suspected activities to the G2.

(2) Report enemy propaganda. Forward copies of leaflets through your S2 as soon as possible.

(3) Segregate from other EPWs those personnel apprehended in the act of espionage, sabotage, or subversion or found in circumstances which indicate they were employed covertly by the enemy.

f. *Enemy Prisoners of War.*

(1) Use the five "Ss" (search, silence, segregate, safeguard, and speed to the rear) when processing EPWs.

(2) Tag EPWs and documents and material of possible intelligence value providing the minimum following information: DTG, location of capture, capturing unit, and circumstances of capture.

(3) Escort EPWs to the unit EPW collection point. Do not take EPWs near CPS, TOCs, FDCs, or radios.

(a) Committed brigades establish an active, and designate one future, EPW collection point near the MSR or SR. The division PM recommends the location, and one future location, of the division EPW collection point to the division G3 for approval.

(b) Units subordinate to brigades must guard and evacuate captured EPWs to brigade collection points. The division PM is responsible for transporting EPWs to the division collection points.

(c) Capturing units evacuate wounded EPWs to battalion aid stations. The unit will evacuate treated and released EPWs to the EPW collection point at brigade.

(4) Conduct tactical interrogation at the unit level only for information of immediate tactical value. Do not unnecessarily delay evacuation of EPWs to expert interrogators.

(5) Treat EPWs in the following manner to aid in follow-on interrogation:

- Screen for NBC contamination and decontaminate as required.
- Give medical aid as necessary.
- Give food and water only to sustain life. EPWs should not be given comfort items such as candy or cigarettes.
- Report their capture by the fastest means.
- Ensure guard and escort personnel are firm but fair when dealing with EPWs. Do not allow other friendly personnel to conduct unnecessary conversations with the EPW.
- Evacuate EPWs in the following priority: field grade or higher ranking officers; intelligence, security and chemical personnel; and other EPWs.

(6) After interrogation, evacuate EPWs in the following categories:

• Category A: EPWs that are of most interest, including general officers and those with knowledge of intelligence, NBC, psychological warfare, logistics, communications, and cryptographic operations.

• Category B: EPWs with some limited intelligence value.

• Category C: EPWs with no immediate tactical value.

• Category D: EPWs with no intelligence value.

g. Captured Documents and Equipment.

(1) Sort captured documents and equipment into these established categories:

• Category A: Documents and equipment with immediate tactical or strategic value.

• Category B: Cryptographic items.

• Category C: Items of lesser value to intelligence.

• Category D: Items with no apparent value.

(2) Report enemy equipment which is new, unusual, or NBC-related or documents that appear to be of immediate tactical value.

(3) Tag captured documents and evacuate them by the fastest means. Do not mark or deface documents. Do not destroy captured documents unless recovery by the enemy is imminent. Never destroy captured medical supplies or equipment. Report any destruction of captured material.

(4) Contact G4 for EOD assistance in the recovery and evacuation of captured ammunition and explosives. Report as with other captured materiel.

h. *Use of Challenge and Password.*

- (1) All assigned or attached units will use challenges and passwords found in current divisional SOI.
- (2) Challenge and password changes are at 1200 hours each day

i. *Reconnaissance and Surveillance.*

- (1) All units will conduct reconnaissance patrolling unless otherwise directed. Units will routinely be assigned R&S responsibilities by the division.
- (2) MSCs or separate battalions in contact should report information or intelligence derived from patrols to the G2 at the TAG CP. Others report to G2 at the division's main CP immediately after mission completion and debrief.
- (3) Committed MSC consolidates battalion-level plans and submits them to the G2 at the TAC CP not later than one hour after the MSC occupies a static position. Other elements submit directly to the main or rear CP G2 as appropriate.

A-22. NBC Procedures.

a. *Mission Oriented Protective Posture (MOPP).*

- (1) The division will designate the minimum MOPP level. Subordinate commanders and leaders may increase or decrease the MOPP level as required but will not decrease the MOPP level below the established minimum level.
- (2) MOPP Uniform.
- (a) MOPP 0.
- Mask and hood—carry on soldier's body.
 - Overgarment—carry in rucksack.
 - Overboots—carry— in rucksack.
 - Gloves—carry in rucksack.
- (b) MOPP 1.
- Mask—carry on soldier's body.
 - Overgarment—worn.
 - Overboots—carry in MOPP pocket.
 - Gloves—in MOPP jacket pocket.
- (c) MOPP 2.
- Mask—carry on soldier's body.
 - Overgarment—worn.
 - Overboots—worn.
 - Gloves—in MOPP jacket pocket.
- (d) MOPP 3.
- Mask—worn.
 - Overgarment—worn.
 - Overboots—worn.
 - Gloves—in MOPP jacket pocket.

(e) MOPP 4.

- Mask—worn.
- Overgarment—worn.
- Overboots—worn.
- Gloves—worn.

(3) Mask only. Mask only is a “by exception” level. This condition applies to soldiers in vans, tanks, and similar shelters who are protected from transfer hazard (but not from vapor hazards). Soldiers do not wear protective overgarments or rubber gloves as long as they are protected from direct skin exposure to liquid or solid contamination. (NOTE: Do not use the “mask only” posture when blisters or persistent nerve agents are present.)

b. *Required NBC Teams.* Each unit down to battalion level will establish the following NBC teams to support tactical operations:

- NBC control party.
- Radiological monitoring and survey teams.
- Chemical survey team.
- Chemical monitoring team.
- Decontamination team.

c. *NBC Alarms and Warnings.*

(1) Standard alarms within the division for NBC attack are—

- Vocal: “GAS, GAS, GAS” for suspected chemical or biological attack; “FALLOUT” for arrival of radioactive fallout.
- Sound: metal on metal.
- Visual: (see Hand and Arm Signals, A-14e(1)).

(2) Chemical Threat Warning. The chemical threat warning system reflects the latest intelligence estimate regarding the enemy’s NBC activity. The G2, division chemical officer and G3 recommend the chemical threat serial based on intelligence estimates and reports. The NBC element is responsible for disseminating the serial.

(3) Chemical Threat Serial.

	<u>Probability of Attack</u>	<u>Minimum MOPP Level</u>
0	None	0
1	Low	0
2	Medium	1
3	High	2

d. *NBC Reporting Procedures.* Notify the division’s main CP immediately of the enemy’s first use of NBC weapons. Use prescribed NBC-1 message format and transmit to the NBC element. Two positive M256 detector tests constitute positive identification of chemical agents.

e. *Marking Contaminated Areas.*

(1) The unit detecting the contamination will mark NBC contaminated areas, using the standard marking signs prescribed in FM 3-3 (see NBC marking signs) and report the location to the NBC element. Request assistance in NBC reconnaissance through the NBC element.

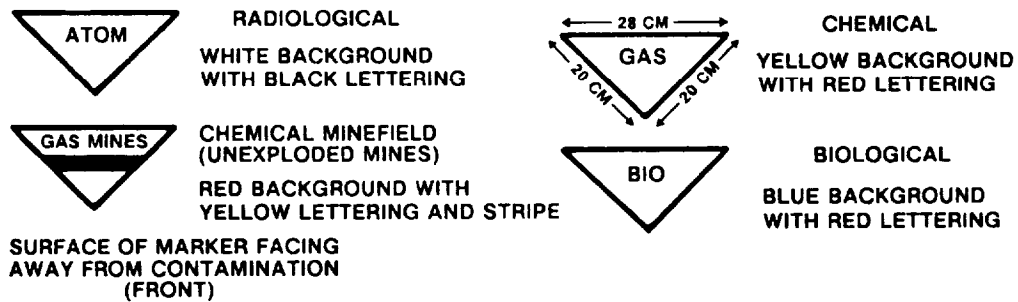

NBC marking signs

(2) Commanders may elect not to mark contaminated areas to obtain a tactical advantage, but they must advise any unit assuming responsibility for the area of contamination.

(3) Changes in the status of contaminated areas will be reported to the NBC element.

A-23. Engineer Procedures.

- a. The assistant division engineer (ADE) directs the missions of general support (GS) engineers.
- b. Priority of transport of class IV and V material to the obstacle site is as follows:
 - Organic engineer units.
 - Supported unit.
 - Other units as directed.

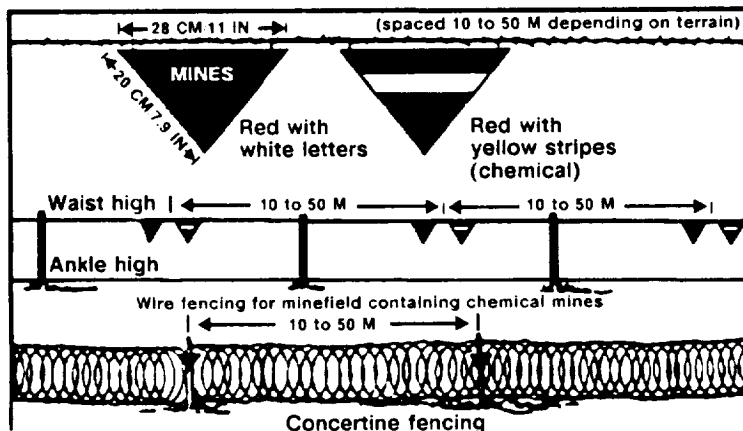

Standard minefield markings

c. Countermobility Procedures.

(1) Obstacle Identification Minefield marking—wire fencing with STANAG 2889 minefield signs. At a minimum, units should make a temporary marking and send a minefield report (see page A-91) with a description of any temporary marking method. The follow-on engineer unit will replace any temporary markings with standard markings according to STANAG 2889.

(2) Scatterable mine procedures.

(a) Long-duration scatterable minefield are emplaced only on approval of the division commander, the ADC-M, CofS, or G3.

(b) MSC commanders may employ short-duration (anything under six hours) scatterable minefield inside division-approved obstacle zones.

d. *Supported Unit Responsibilities.*

(1) Units guard all targets within their sector of responsibility.

(2) Units cover with fire all obstacles within their sector of responsibility.

e. *Route Maintenance and Repair (Mobility).* The division rear CP coordinates requirements for route maintenance, rear area damage control, and prioritization of engineer effort with the ADE at the main CP.

f. *Division Standard Obstacle Packages.*

(1) Triple Standard Concertina (300 meter).

<u>Description</u>	<u>Number</u>	<u>Wt</u>	<u>Cube</u>
Pickets, Long (U)	160	1584	188.8
Tape, Barbed (Dispenser)	4	128	3.6
Pickets, Short (U)	4	16	.24
Concertina, (Roll)	59	1818	64.9
Staples	317	<u>634</u>	<u>65</u>
		4114	322.54

(2) Abatis (20-in diameter trees) Bridge Demolition (2-lane class 60).

<u>Description</u>	<u>Number</u>	<u>Wt</u>	<u>Cube</u>
Explosive, C-4	173 lb	173	3.6
Detonating Cord	1000 ft	77	.6
Time Fuze	20 ft	5	.1
Nonelec Caps	19	neg	neg
Elec Caps	1	neg	neg
Fuze Lighter	1	neg	neg
Mine, AT M15	8	398	9.5
Mine, AP M16	8	<u>90</u>	<u>1.6</u>
		743	15.4

(3) Road Crater M-180.

<u>Description</u>	<u>Number</u>	<u>Wt</u>	<u>Cube</u>
Demo Kit, M180	5	895	32.20
Mine, AT M15	6	294	7.00
Mine, AP M16	4	<u>45</u>	<u>.79</u>
		1234	39.99

(4) Road Crater Standard (31x18x6 Ft).

<u>Description</u>	<u>Number</u>	<u>Wt</u>	<u>Cube</u>
40lb Shape Charge	7	455	13.10
40lb Crater Charge	7	364	9.66
1 1/4 lb C4	7	neg	neg
Detonating Cord	350 ft	27	.90
Time Fuze	20 ft	neg	neg
Elec Delay Caps	1	neg	neg

<u>Description</u>	<u>Number</u>	<u>Wt</u>	<u>Cube</u>
Elec Caps	1	neg	neg
Nonelec Caps	1	neg	neg
Fuze Lighter	1	neg	neg
Mine, AT M15	6	294	7.08
Mine, AP M16	4	<u>45</u>	<u>0.79</u>
		1185	31.53

(5) Row Minefield M-15 (200 x 0.5) Three Strip Surface Laid.

<u>Description</u>	<u>Number</u>	<u>Wt</u>	<u>Cube</u>
Mine, AT M15	110	5390	131.5

(6) Survivability Positions (30 Positions).

<u>Description</u>	<u>Number</u>	<u>Wt.</u>	<u>Cube</u>
Sheet 3/4" Plywood	15	960	30.0
Pickets, short (U)	120	480	7.2
Sandbags, Unit	6000	<u>1500</u>	<u>60.0</u>
		2940	97.2

(7) Demolition Pack.

<u>Description</u>	<u>Number</u>	<u>Wt</u>	<u>Cube</u>
Explosive C4	173 lb	173	3.6
Detonating Cord	1000 ft	154	1.2
Time Fuze	20 ft	10	.2
Nonelec Caps	19	neg	neg
Elec Caps	1	neg	neg
Fuze Lighter	1	<u>neg</u>	<u>neg</u>
		327	5.0

g. Engineer Obstacle Numbering System.

(1) The division ADE establishes obstacle zones and obstacle restricted areas to support division tactical operations. Obstacle and obstacle restricted zones are designated with a letter (Zone A) and obstacle belts are identified by numbers (Belt 3).

(2) Subordinate units are not authorized to emplace obstacles in other than designated obstacle zones.

(3) Subordinate engineers supporting the division maintain obstacle numbers. The eleven character obstacle number is shown on overlays within the unit. The engineer unit emplacing or supporting the obstacle maintains engineer obstacle numbers and folders following the procedures prescribed in FM 5-102.

A-24. Field Artillery Procedures.

a. Artillery-delivered scatterable mines.

(1) The standard division artillery delivered scatterable minefield is 400 by 400 meters, medium density, short duration.

(2) Emplacement of long-duration FASCAM requires the commanding general (CG), ADC-M, CofS, or G3 approval. Short-duration FASCAM can be approved by brigade commanders.

b. *Chemical Employment.* Firing elements must obtain verification to fire from properly authenticated digital or voice fire missions through field artillery channels. Proper authentication is confirmation that the CG has granted permission to fire. *Under no circumstance will a chemical mission be fired without proper authentication.*

c. *Quick-Fire Channels.* DIVARIY establishes quick-fire channels on FA communications nets to expedite fires.

d. *Calls for Fire by Non-FIST Observers.* Units without a FIST element will attempt to pass the mission to a higher fire support element. If no fire support element is available, the unit should contact a field artillery FDC directly. All requests for fire must be authenticated.

e. *Mass Fire Missions.*

(1) *Normal mission processing* using the TACFIRE allows for the massing of artillery fires by processing a request for additional fires (RFAF) through the DIVARTY computer. A method of fire control (TOT, AMC) must be identified to ensure all elements are ready to fire at the appropriate time. (Normally the FDC will designate the method of fire control.)

(2) An IRON HAMMER is a *preplanned mass mission*. It delivers about one module of ammunition against a specific engagement area. IRON HAMMER requests are sent to the division FSE and managed like preplanned CAS. The division's TAC FSE may divert a planned IRON HAMMER to the most critical engagement that the division commander sees.

(3) The 105-millimeter FA battalion standard ammunition module consists of a battalion-six ICM and will—

- *Neutralize* a motorized rifle battalion (about 10 percent fractional damage).
- *Suppress* a tank battalion (about 3 percent fractional damage).
- *Neutralize* a field artillery battalion (about 15 percent fractional damage).

(4) Immediate mass missions may be approved by only the CG, ADC-M, or G3. Immediate mass missions interrupt normal mission processing by a voice request over the DIVARTY command net. Artillery immediate mass missions fall into three categories:

(a) FIRESTRIKE. This is the least disruptive to normal mission processing. It—

- Delivers about one module of ammunition.
- Is fired by GS 155-millimeter battery.
- Usually requires 10 to 15 minutes notice and is over within five minutes. It is normally executed as a time on target (TOT).
- Target engagement criteria will be the decision of the DIVARTY TOC.

(b) THUNDER. This is moderately disruptive to normal mission processing. It—

- Delivers about three modules of ammunition.
- Is normally fired by GS, general support reinforcing, or reinforcing artillery units.
- Usually requires 15 to 20 minutes notice and is over within 10 minutes. It is normally not executed as a TOT but as a window of time within which available units may deliver the fires.
- Target engagement criteria will be four volleys of DPICM from every 155-millimeter or 203-millimeter howitzer within range plus 36 MLRS rockets.

(c) HOT STEEL. This requires the suspension of normal mission processing. HOT STEEL requires the CGS or ADC-M's approval to execute. It—

- Delivers about ten modules of ammunition.
- Is normally fired by all division artillery cannon units within range of the target. This is

true even if the engagement requires units on the move to hipshoot or units in position to shift orientation. The only artillery not required to respond are DS units shooting final protective fire (FPF).

- Usually requires 30 minutes notice, and ends when the CG or TAC CP gives “end of mission.” Due to counterfire vulnerability, battalion S3s may move up to one-third of their fire units after delivering the first set of required volleys. It is normally not executed as a TOT, but as a window of time within which available units may deliver the fires.

- Target engagement criteria will be 12 volleys of ICM from every 105-millimeter howitzer within range and eight volleys of DPICM from every 155-millimeter howitzer within range.

f. Target Numbering System. All the division’s indirect fire targets will be designated by a one-letter and four-digit number. The letters I and O are not used because they can be confused with numbers.

(1) The letter assignments are—

Division	A
DIVARTY	B
1st Bde	C
2d Bde	D
3d Bde	E
Avn Bde	F

(2) Assignment of blocks of numbers for brigade echelons are—

<u>Number</u>	<u>Assigned To</u>
0001-1999	FS cell
2000-2999	FSO, lowest numbered maneuver battalion or squadron
3000-3999	FSO, second lowest numbered maneuver battalion or squadron
4000-4999	FSO, third lowest numbered maneuver battalion or squadron
5000-6999	Additional FSOs
7000-7999	FDC, direct support artillery
8000-8999	Counterfire targets
9000-9999	Toxic chemical targets

(3) Subassignment of blocks of number for battalion echelons are—

<u>Numbers</u>	<u>Assigned To</u>
000-199	FS cell
200-299	FIST, Co A
300-399	FIST, Co B
400-499	FIST, Co C
500-599	FIST, Co D
600-699	Additional FISTs and COLTs
700-799	Battalion mortar platoon, scouts, or howitzer battery
800-899	As required

(4) Target number assignments for division troops are—

Recon Sqdn	A 0001-0499
Rear CP FSE	A 0500-0999
Tactical CP FSE	A 1000-1249
Engr Bn	A 1250-1499
ADA Bn	A 1500-1749
MI Bn	A 1750-1999
Main CP FSE	A 2000-9999

g. Laser Pulse Codes.

(1) Laser pulse codes will be managed in the division by the division's FSE, including codes for AH-64 attack helicopters.

(2) The current laser pulse code distribution is:

- 1st Brigade FSO: 351-358, 361-368, 371-378, and 381-388.
- Ž 2d Brigade FSO: 171-178, 181-188, 211-218, 221-226, and 341-348.
- Ž 3d Brigade FSO: 231-238, 341-248, 251-258, and 331-338.
- Ž Avn Brigade FSO: 261-268, 271-278, 281-288, 311-318, 321-328, and 411-418.
- Recon Squadron FSO: 441-448, 451-458.
- The division left flank codes of 111-118 and the right flank codes of 121-128 will be allocated in plans and orders.
- Division FSE (reserve): 421-428, 431-438.

A-25. Army Air Procedures.

a. OH58D Priorities of Employment.

- (1) Support of cross-FLOT or attack operations.
- (2) Targeting support for DIVARTY.
- (3) Reconnaissance.

b. Supported Unit Responsibilities.

- (1) Request aviation resources as far in advance as possible:
 - Day missions—12 to 24 hours planning.
 - Ž Night missions—18 to 36 hours planning.
 - Ž AH-64 mission—24 to 72 hours planning.
- (2) Select and secure the LZ or PZ.
- (3) Provide LZ and PZ control, 6-digit grid location of LZ and PZ, and frequencies and call signs to the aviation unit.
- (4) Brief the aviation POC on current enemy and friendly situation, fire support measures, and control measures.
- (5) Provide transportation from the LZ and PZ to the TOC for briefing.
- (6) Provide slings, nets, and a qualified rigger for external load.
- (7) Provide ground guides and hookup personnel for external load operations.

c. LZ and PZ Selection and Preparation.

- (1) Size:
 - UH-60 or smaller aircraft—20 by 20 meters.
 - CH-47-60 by 60 meters.
- (2) Surface Condition:
 - Able to support weight of helicopter without sinking.
 - Free of debris.
- (3) Ground Slope. 10 to 15 (degrees) maximum.

(4) Obstacles:

- Free from trees, powerlines, or telephone poles.
- Ž Stumps and rocks that can't be removed marked.

(5) Marking Landing Site:

- Ž Mark landing point for lead aircraft.
- Ž Use lights (IR filters, as required), VS-17, or smoke.

(6) Aircraft Capabilities. Direct liaison with the supporting aviation unit is authorized and encouraged to verify planning capabilities. Normal division aircraft capability planning factors are shown below:

<u>TYPE</u>	<u>OH-58A/C</u>	<u>OH-58D</u>	<u>UH-1H</u>	<u>AH-1</u>	<u>UH-60</u>	<u>AH-64</u>	<u>CH-47</u>
Cruise Speed (knots)	100	100	100	120	140	140	155
Endurance	2+30	2+30	2+15	2+30*	2+15	1 + 45*	2+30
Passenger	3	0	9	0	14	0	33
Cargo Doors Dimensions	40x35	N/A	74x48	N/A	68x54	N/A	90x78
Internal Load	700	N/A	2,500	N/A	3,500	N/A	11,500
External Load	N/A	N/A	4,000	N/A	8,000	N/A	25,000

*Maximum endurance without armament.

A-26. Attachment and Detachment Procedures.

a. *Headquarters Ordering the Transfer.*

- (1) Specifies gaining and losing headquarters.
- (2) Specifies task organization of unit to be transferred, including logistics and support requirements.
- (3) Specifies date-time group the transfer is effective.
- (4) Specifies the route transferred unit will use.

b. *Losing Headquarters.*

- (1) Provides the transferred unit with the CSS necessary to sustain itself for at least 12 hours (for a company or team) or 24 hours (for a battalion or TF), such as—
 - Appropriate transportation for personnel and ammunition.
 - Mechanics, tools, and parts (with transportation).
 - Medics, class VIII, and ambulances.
 - Class I.
 - Ž Class V.
- (2) Provides to transferred unit—
 - SOI extracts of gaining headquarter's command, logistics, and indirect fire networks.
 - Route, movement time, and recognition signal at link-up point.
- (3) Ensures that—
 - The transferred unit leaves with full fuel and ammunition loads.
 - Ž The transferred unit continues to receive personnel and equipment replacements and repaired equipment earmarked for it prior to the transfer.

c. Gaining Headquarters.

(1) Provides to the transferred unit at the link-up point a guide who knows or possesses the following information:

- Ž The mission and concept (including graphics) for the transferred unit.
 - The gaining unit's logistics unit locations.
 - Access to the gaining unit's indirect fire nets.
 - The situation in the gaining command's sector or zone.

(2) Provides fuel top-off of transferred unit bulk carriers.

(3) Provides ammunition as required and available.

(4) Provides communications information, including—

- Frequencies, call signs, and secure fills.
- Ž Gaining unit's SOI for the transferred unit commander.
 - Pyrotechnic and other visual signals, as required.

d. Transferred Unit.

(1) Moves over assigned route to RP at times assigned.

(2) Contacts gaining headquarters on FM secure radio before reaching the link-up point and provides the gaining command a unit status report and logistics requirements (for example, fuel, personnel, and ammunition).

(3) Dispatches a LO to the link-up point as soon as possible after receiving the transfer order.

(4) Is prepared for commitment to combat directly from the link-up point.

e. Staff Responsibilities.

(1) G3 and S3 Responsibilities.

(a) Inform the staff and other subordinate or adjacent units of the following:

- Units being attached and detached.
- Period of attachment and detachment.
- Ž Changes to existing task organization.
- Changes in assigned boundaries.
- Ž Current and proposed locations of headquarters that will exercise control.

(b) Brief the gaining headquarters on current situation and planned actions.

(c) Coordinate route, link-up point, and movement control of the attached or detached force.

(d) Brief the gaining headquarters of any pertinent information concerning the capabilities and limitations, unique weapons systems, and or employment of the attached or detached unit.

(2) G4 and S4 Responsibilities.

(a) Arrange logistics support for the unit.

(b) Coordinate, in conjunction with the G3 or S3 and the DTO, the movement of units through the division's area of operations.

(c) Notify DISCOM or forward support battalion of the unit involved and its effective DTG of attachment or detachment so that resources may be reallocated as appropriate and flow of supplies continues uninterrupted to the detached unit.

(d) When the attachment or detachment involves a brigade, coordinate for the attachment or detachment of the forward support battalion and any other logistics support.

(3) G2 and S2 Responsibilities.

(a) Assist G3 or S3 in the development of plans which control the execution of attachment and deny enemy knowledge of the activity.

(b) Provide the gaining headquarters an assessment of the enemy situation along both flanks of proposed employment.

(c) Be prepared to coordinate with the MSB for maps.

(4) Signal Officer Responsibilities.

(a) Develop a signal support plan and request additional support if necessary.

(b) Determine SOI requirements for the attached unit and distribute sufficient copies as required.

(5) Unit Commander Responsibilities.

(a) Tailor a complete support package from organic assets to sustain detached forces of company or team size or larger.

(b) Ensure that the gaining command receives personnel and equipment status reports from the detached unit immediately upon its arrival.

f. *Standard Task Organizations.* The division will use the following standard task organizations when attaching or detaching units. These will be used for planning purposes only and may be modified to meet the current situation.

(1) Infantry Brigade:

- HHC
- 3 Infantry Battalions
- 1 105-mm (T) DS Artillery Battalion
- 1 Engineer Company
- 2 MSE Extension Nodes
- 1 FSB

(2) Infantry Battalion:

- HHC
- 3 Infantry Companies
- 1 Medical Platoon
- 1 Scout Platoon
- 1 Mortar Platoon
- 1 Antitank Platoon

A-27. Heavy Forces Integration Procedures.

a. The division requests the support of a heavy battalion or brigade for support in tactical operations. The preferred unit is a separate heavy brigade, second choice is a divisional brigade. Under NO circumstances does the division accept heavy forces from higher headquarters without a viable mission requirement and appropriate support packages. The support package should include as a minimum:

Ž FSB normally associated with the brigade.

- HETs with drivers from the MSB TMT company.
- Fuel and cargo HEMTTs with drivers from the MSB supply and service company.

b. The division's CofS provides a LO team to interface with the division's tactical CP and heavy brigade CP.

c. *Standard Heavy Brigade Task Organization.*

HHC
 3 Battalions (Mechanized Infantry or Tank)
 1 155-mm (SP) Battalion
 1 ADA Battery (Gun/Stinger)
 1 Engineer Battalion
 1 Military Police Platoon
 1 FSB
 2 MSE Extension Nodes

d. *Standard Heavy Battalion Task Organization.*

HHC
 4 Companies (Mechanized Infantry or Tank)
 1 Antitank Company (if Mech)
 1 Scout Platoon
 1 4.2"-Mortar Platoon
 1 Engineer Company

A-28. Logistics Procedures.

a. The Logistics Spot Report (Yellow 1) is used by all divisional units to report immediate combat losses of equipment and personnel. Unless otherwise indicated, all logistics reports (Yellow and Red) are "report by exception."

b. Assigned or attached units receive logistics support from the nearest support battalion on an area basis.

c. Units in general support of the division receive primary logistics support from their parent unit. Limited resupply of class—I, II, IV (less obstacle), IX—and maintenance, medical, water, and services are available at nearest support battalion.

d. The G4 is the POC for interservice logistics requests and agreements. The G4 coordinates with the supporting corps finance group to obtain funding support for local contracting and procurement efforts.

e. *Reconstitution Procedures.*

(1) Reorganization. During tactical operations the division conducts reorganization of available assets to maintain effectiveness of designated units.

(a) Reorganization is the action to shift resources within a degraded unit to increase combat power when the division is committed to tactical operations. The massing of vehicles, personnel, class V, and class III of several different units into one unit is required during this process. The maintaining of small-unit integrity is a primary consideration.

(b) The authority to reorganize and consolidate units rests with the commander two levels above the unit to be reorganized.

(c) Only the division commander can authorize the retirement of unit colors.

(d) Any reorganization conducted at any level within the division must be immediately reported through both operations and logistics channels upon completion.

(e) Minimum Manning Levels. Prior to initiating the process of reorganizing, units should attempt to tight weapons systems at minimum manning levels. Permission to go to minimum manning

levels will be retained by battalion commanders. The following are minimum manning levels authorized within the division on specified equipment.

<u>System</u>	<u>Authorized Manning Level</u>	<u>Minimum Manning Level</u>
Howitzer	9	5
Mortar Crew	4	3
Vulcan	4	3
Stinger	2	1
TOW HMMWV	4	2

(2) Regeneration. The division conducts regeneration operations when in a disengaged status and located in a secure rear assembly area.

(3) Weapons Systems Replacement. Weapons system replacement operations are conducted to provide fully operational, ready-to-fight replacement weapons systems, both vehicle and crew. The division does not link up personnel and equipment when it is in a committed status. The normal size of replacement units coming to the division will be at the platoon level. Larger-sized units will be received on an exception basis after coordination with corps. Responsibilities are as follows.

(a) The division G3 is responsible for determining priority for weapons system replacement. The G4 initiates the request to the corps. Final assignment decisions for replacement weapons systems are made by the G3.

(b) The division MMC is responsible for coordinating the movement, reception, and processing of all incoming replacement units from corps, and delivery to the receiving unit.

(c) Replacement weapons systems or units are moved into an assembly area in the vicinity of the division rear command post. The G4 coordinates with the rear command post G3 operations element for designated assembly area.

(d) Once located in the assembly area, the division G4 coordinates the following functions prior to releasing the unit:

 • Shelter and sleeping area for new crews.

- Personnel actions to process crew into the division.

 • Resupply of class III and class V.

- Maintenance checks for vehicles.
- Vehicle and personnel precombat inspections as per the TSOP.
- Individual weapons for new crew members.
- Map or physical reconnaissance of the local area to vehicle commanders and key leaders.

 • While in the assembly area, tasking the unit with local security missions to begin team training and equipment familiarity.

 • Assessing the unit's training status for input to receiving unit and, if time permits, conduct of crew drills and small-unit training in rear area.

(e) On order, replacement units are sent to the BSA.

(f) Receiving unit links up with replacement unit at BSA and leads to final location.

f. *Supply.*

(1) General.

(a) CSR is RSR. Controlled supply rate (CSR) is established when required supply rate (RSR) exceeds resupply capability.

(b) Throughput distribution from corps to the division support area and brigade support areas is the normal method of operations.

(c) Unless otherwise requested, LOGPACs deliver standard supply packages to forward units. Preconfigured unit loads (PULs) consolidated by corps are prepared to provide direct shipment to the user whenever possible, eliminating double handling within the division.

(d) No supply vehicle ever sits empty except for maintenance.

(2) Supply Specifics.

(a) Class I:

- Unit basic load (UBL) is three days of supply (DOS) of MRE.
- Division's minimum authorized stockage level (ASL) is two DOS. This does not include UBL maintained by units.
- Ration cycle is T-MRE-T.
- Class I standard resupply packages (one DOS):

Unit	<u>Meals</u>	<u>Cases</u>
Inf Bn	1,710	144
Inf Co	390	34
Arty Bn (DS)	1,218	102
Arty Btry (GS)	417	35
ADA Btry	360	30
Recon Sqdn	939	79
Engr Co	189	16

(b) Classes II and IV (less obstacle): UBL is 15 DOS.

(c) Class III and IIIA package:

Ž UBL class IIIA (Package) is 15 DOS.

- Class III package based on 75 percent of vehicle fuel capacity:

Unit	<u>Gallons</u>	<u>600 Gallon TPU</u>
Inf Bn	656	1
105-mm Arty Bn	2,490	4
155-mm Arty Btry	1,694	3
ADA Btry	1,510	3
Cav Trp (Ground)	412	1
Engr Co	283	1

(d) Water: UBL is two DOS.

(e) Class V: The division uses combat configured loads (CCLs) to simplify planning and coordination for ammunition resupply. The CCL class V packages are delivered by LOGPACs to user units in the amounts and types of munitions prescribed here unless requested differently in a Yellow 3 report. The following CCL packages are designated as CCL-A:

Type <u>Unit</u>	<u>Description</u>	<u>Rounds Provided</u>
Infantry Company	5.56 Ball	12,600
	5.56 Tracer	2,100
	5.56 4/1	3,600
	7.62 4/1	7,200

<u>Type Unit</u>	<u>Description</u>	<u>Rounds Provided</u>
Infantry Company	9-mm Ball	200
	60-mm HE	480
	60-mm Illum	10
	60-mm WP	40
	66-mm Rkt HE	5
	84-mm Rkt AT4	5
	Dragon Msl	6
	Gren Hnd Smk	15
	Gren Hnd Frag	65
	Gren Smk HC	15
	Gren Smk Color	15
	Mine AP M18	10
	Trip Flare	15
	Gren 40-mm HEPD	380
	Gren 40-mm Illum	38
Gren 40-mm Smk Color	38	
Star Cluster Color	38	
Scout Platoon	5.56 Ball	3,000
	5.56 Tracer	500
	5.56 4/1	600
	66-mm Rkt HE	5
	Gren Hnd Frag	20
	Gren Smk HC	10
	Gren Smk Color	10
	Mine APM18	8
	Star Cluster Color	5
Mortar Platoon	5.56 Ball	2,700
	5.56 Tracer	100
	81-mm HE	337
	81-mm Illum	10
	81-mm WP	27
AT Platoon	5.56 Ball	2,400
	5.56 Tracer	100
	66-mm Rkt HE	10
	Msl TOW	12
	88-mm Rkt AT4	5
	5.56 Ball	1,200
ADA Battery	5.56 Tracer	200
	20-mm HEI	950
	20-mm HEI-T	3,000
	Stinger	20

<u>Type</u> <u>Unit</u>	<u>Description</u>	<u>Rounds</u> <u>Provided</u>
Division Recon Squadron	5.56 Ball	20,000
	5.56 Tracer	800
	7.62 4/1	3,600
	Gren 40-mm HEPD	380
	50 Cal 4/1	3,600
	20-mm HEI	7,600
	Msl TOW (Ground)	15
	Msl TOW (Air)	15
	2.75 Rkt HE	50
	2.75 Rkt Smk	8
	2.75 Rkt Illum	16
105-mm Field Artillery Battalion	HE	180
	WP	4
	Illum	2
	Smk	15
	HCBE	108
	HE ICM	24
	APERS	7
	Fuze MT	130
	Fuze MTSQ	110
	Fuze PD	90
	Fuze Prox	50
155-mm Field Artillery Battery	ADAM	10
	Illum	8
	HCBE	12
	HE RAP	15
	R U M	10
	HE APICM	60
	HE DPICM	80
	Chg White Bag	54
	Chg Green Bag	68
	Chg Red Bag	50
	Fuze MTSQ	75
	Fuze PD	85
	Fuze Prox	60
Primer	180	

(3) Maintenance Specifics.

(a) Priority of repair is weapons systems, command and control vehicles, and transportation assets. During tactical operations, emphasis is on battle damage repair.

(b) Responsibilities:

Ž DISCOM: ground, missile, COMSEC items, and class IX.

• Aviation brigade: aviation.

Ž MI battalion: organic surveillance and jamming equipment.

- Corps support group: provide reinforcing direct support on an area basis.
- Area support group: provide general support maintenance on an area basis.

(4) Repair time guidelines:

- Brigade support area—up to 12 hours.
- Ž Division support area—12 to 48 hours.

(5) Evacuation responsibilities:

Ž Unit: To the unit maintenance collection point (UMCP).

- Support battalion: From UMCP to BSA.

Ž DISCOM: From BSA to DSA.

Ž Corps support command provides backup recovery and evacuation as coordinated by the DISCOM.

g. *Services.*

(1) Clothing Exchange and Bath:

- Laundry service is direct exchange (DX) only.
- Ž Support battalion schedules and positions.
- Service is on an area basis.

(2) Bath. Priority of support:

- Ž Committed troop units.
- Ž Medical treatment facility patients.
- Ž Troop units in rest area and or unit assembly areas.

(3) Mortuary Affairs.

(a) Noncontaminated Remains:

Ž Initial search, recovery, identification, and evacuation of remains to the battalion combat trains is a unit responsibility. Personal effects are kept with the remains.

- Remains are transported from unit combat trains to the BSA graves registration point (Mortuary Affairs Collection Points) and ultimately to the DSA.

- No combat power will be bled off to carry personnel KIA to the rear.

Ž Division must designate a unit or personnel and initially OPCON them to DISCOM to operate brigade and division collection points and coordinate subsequent operations until mortuary affairs (MA) unit arrives.

Ž Units maintain two DOS, UBL MA supplies. DISCOM maintains 30 DOS, ASL.

Ž Formula for determination of UBL: Troop strength X (.0025) X two days.

(b) Contaminated remains:

- Treat all remains found in a contaminated area as contaminated.
- Remains collected by unit placed in body bags (if available).
- Remains placed in mass grave (expedite). Unit personnel will not evacuate contaminated remains to MA collection point.

Ž Grave marked as contaminated area.

Ž Grave reported to G1 for graves registration and coordination for removal. MA personnel will process and evacuate contaminated remains.

h. *Transportation.*

(1) General.

(a) Requests for additional transportation support (except emergency aerial resupply) submitted to the DISCOM MCO through the FSB or MSB.

(b) Link-up points must be provided by all units that submit transportation requests.

(c) The supported unit provides personnel and equipment to load, secure, and unload cargo.

(d) If transportation assets have not arrived 30 minutes after the scheduled time, the supported unit will—

- Contact the DISCOM MCO through the FSB.
- Ž Search for the equipment in the area surrounding the pick-up point.

(e) Transportation operators remain on site for one hour after the scheduled load or unload time. They then—

- Contact the FSB for instructions.
- Look for the unit's representative in the area.

(f) Supported units report to the FSB not later than 30 minutes after—

- Ž The arrival of trucks by quantity and type (including cargo if loaded).
- The departure of trucks by quantity and type (including cargo if loaded).

(2) "Surge" Transportation.

(a) Surge requests are submitted to the MCO through the DTO at the rear CP.

(b) CSS operations requests submitted by 1200 hours are considered for shipment the following day.

(c) The MCO determines if the required transportation assets are available. If not, the MCO coordinates with the DTO who then submits a request to corps.

(d) The MCO coordinates with the DTO to determine shipping priorities when high-priority cargo exceeds transportation capabilities.

(e) Emergency requirements as determined by the MCO are processed immediately.

(3) Aviation Transport Operations.

(a) Mission request processing is as follows:

- The requesting unit S4 or G4 submits an aerial resupply or transportation request through the FSB or MSB to the MCO.
- The MCO determines if air transport is the appropriate mode and coordinates with the division's aviation brigade operations.
- The DTO arranges for aerial transport from corps to meet requirements that exceed division capabilities.
- Noncritical air movement requests are processed according to current tactical priorities.
- Ž Cargo security, except in flight, is both the shippers' and the receiving unit commander's responsibility.

(b) Units requesting air transportation—

- Prepare supplies or personnel for delivery (helicopter or fixed wing).
- Supervise and load the aircraft. The aircraft crew chief ensures that the aircraft is loaded within the prescribed weight and balance requirements.

(c) Units receiving air transportation—

- Establish and mark LZ.
- Coordinate for sling load equipment, rig loads, and recover the slings. They recover and evacuate DISCOM slings after use.

i. *Refuel on the Move (ROM).*

(1) The division conducts ROM operations along the route(s) of march short of the release point or line of departure in order to extend the operating range and conserve units uploaded UBL of class III.

(2) Division tactical priorities and DISCOM tanker limitations necessitate detailed prior coordination between the G3 or G4, DISCOM, and refueling MSC.

(3) Unit requirements for ROM sites include—

- The site is out of direct fire.
- Local air parity exists.
- The site is in a non-NBC contaminated area.
- The site is near or on a hard surface road.
- Easy ingress and egress routes exist.

(4) Responsibilities.

(a) Division G4—

Ž Approves ROM operations (after coordinating with the G3).

- Establishes the general time-phasing and route of march (if outside the brigade sector).
- Coordinates for military police, engineer, and ADA support at ROM sites.

(b) Brigade S4—

- Designates the refuel site in coordination with division, DISCOM, and FSB.
- Ž Establishes link-up time at the refuel site for each task force.
- Determines the approximate fuel required and establishes the refuel time at the ROM site for each vehicle, for example, four minutes per vehicle.
- Transmits fuel requirements to DISCOM through the support battalion.
- Maintains continuous coordination with DISCOM and attached or OPCON battalions.
- Coordinates for security at the refuel site.

(c) Refueling battalion—

• Does detailed march planning and organizes march units for combat to speed movement and refuel operations.

- Provides security of the refueling site by—
 - Reconnoitering the route and securing the refuel site.
 - Assisting the DISCOM with site and equipment preparation.
 - Manning the refuel coordination point.

Ž Determines fuel requirements and transmits these to brigade during the ROM planning and coordination process.

- Controls the unit and manages its flow through the ROM site.

(d) DISCOM—

- Coordinates the timing, location, and fuel requirements with division, brigade, and FSB.
- Provides assets to support ROM.

- (e) Support battalion—
- Executes the ROM and controls the ROM site in coordination with brigade or battalion S4s.
 - Ž Reconnoiters refuel sites and establishes traffic control pattern.
 - Ž Forwards fuel and tanker and equipment requirements for ROM operations to DISCOM.

A-29. Personnel Support Procedures.

a. Personnel.

(1) General.

(a) The G1 deploys in two elements: one in the division main CP and the other in the division rear CP.

(b) The personnel service battalion (PSB) is a corps asset which complements the division's personnel system. Postal company is a corps asset that collocates with the rear CP. Red Cross support must be formally requested. Red Cross unit locates in vicinity of the G1 cell, rear CP. Safety personnel also collocate with G1 at rear CP.

(2) Personnel Accounting and Strength Reporting System.

(a) The Logistic Spot Report, and Red 1 and Red 2 reports, are the primary means of reporting personnel strengths.

(b) Company commanders account for soldiers. They report strength accountability and duty status changes to the battalion S1 who enters the information into the total Army personnel data base (TAPDB) through standard installation/division personnel system (SIDPERS) transactions. Personnel accounting data converts from written or verbal to an automated format at the G1 level.

(c) Strength reporting is a numerical end product of the accounting process. Strength reports are available from battalion to division level through the command and control strength reporting system on the tactical army combat service support computer system. The personnel summary report (PSR) and personnel requirements report (PRR) are the primary personnel reports. Manual reports to account for personnel and report personnel strengths may also be used.

(d) Units deploying with different elements as part of a task organization will provide the gaining headquarters a battle roster on a standard floppy disk.

(e) Losing units will not provide strength reports for units which are no longer part of their task organization.

(f) Brigade headquarters provide all strength-related reports for all elements task-organized under them.

(3) Personnel Replacement Operations.

(a) Assignment of enlisted soldiers is made to battalion, separate company, or separate detachment level.

(b) Brigades will manage officer and warrant officer assignments within the brigade.

(c) Separate battalion or companies not attached or assigned to a brigade receive replacements through the nearest replacement company.

(4) Casualty Reporting.

(a) Witnesses report casualties on a DA Form 1155 (Witness Statement on Individual) and or a DA Form 1156 (Casualty Feeder Report) or any other means available to report as much information as possible. This information is forwarded to unit personnel administration centers (PACs).

(b) Every soldier carries DA Form(s) 1155 (Witness Statement) and DA Form(s) 1156 (Casualty Feeder Report). When DA Forms 1155/1156 are not available, use any other means to report as

much information as possible. Witness Statement is completed when a casualty occurs and the body is not recovered. The 1156 (Casualty Feeder Report) is completed on every casualty.

(c) Forward DA Forms 1155/1156 through unit PACs to the Personnel Service Battalion.

(d) Do not delay reports because of missing or unknown data. Commanders and soldiers should continue to seek missing information and forward as recovered.

(e) Multiple reports by different individuals may be submitted on the same soldier and/or incident.

(f) Completing more than one 1155/1156 is encouraged. Route each to the PSB through a different mode and/or carry one copy until it can be safely delivered to the PSB. This eliminates the loss of critical casualty information as the result of a lost or destroyed DA Form 1155/1156.

(g) The DA Form 1155 (Witness Statement) is completed when the body is not recovered.

(h) The DA Form 1156 (Casualty Feeder Report) is completed by the soldier(s) most knowledgeable (on the scene) of the incident causing the casualty. It is completed on every casualty.

(i) Accurate casualty reporting begins at the scene and relies on the soldiers who witness the casualty. Commanders must ensure soldiers carry and complete these documents during training as well as combat.

(5) Recovered US and Allied Personnel.

(a) US and allied personnel recovered from enemy controlled territory are transported to the supporting replacement detachment for processing and reassignment. Returnees requiring medical treatment process through the division's medical channels.

(b) Units recovering US and allied personnel will report the following information to the G1 support element at the rear CP:

Name:

Nationality:

Parent Service: (If US military)

Rank/Grade:

Service Number/SSN:

Disposition: (for example, transported to field hospital)

b. *Postal.* Wartime postal support: The division's supporting DS postal platoon will collocate operations with the supporting PSB.

(1) The G1 notifies units of any mail restrictions.

(2) The postal platoon will receive, process, and dispatch mail by battalion and separate company.

(3) The PSB commander, in coordination with the G1, establishes the postal platoon location.

(4) Mobile postal finance teams setup operations at the BSA where unit mail orderlies purchase stamps and money orders for their unit personnel.

(5) Mail received by a unit after an individual is placed in a casualty status is returned to the postal platoon for redirecting.

(6) All mail and postal effects threatened with capture by the enemy or NBC contamination must be burned or shredded. The postal officer coordinates the destruction of mail and postal effects with the

G1, unless the tactical situation dictates immediate action. Destruction priorities for mail and postal effects are—

- Priority one-official registered mail.
- Priority two-US Postal Service (USPS) funds and stamp stock.
- Priority three-official nonregistered mail.
- Priority four-personal mail.
- Ž Priority five-remaining postal equipment and supplies.

c. *Finance.*

(1) On declaration of war, the payment of travel and per diem for travel performed entirely in the theater of operations is not authorized.

(2) Unit S1 and G1 elements are responsible for coordinating with the local servicing finance unit for local purchase funding and pay support.

(3) The PAC is the central POC between soldiers and the supporting finance unit. The PAC resolves less-complicated pay inquiries and coordinates with the finance unit to solve all others.

d. *Band Support.* The primary mission of the band is playing music. If the tactical situation makes this impractical, the band will augment security, EPW, or traffic control units as needed. The bandmaster is responsible for the control of the band and under the staff supervision for the G1.

e. *Health Service Support—Operations.*

(1) Division surgeon—

Ž Provides technical supervision and control over all medical units and elements in the division.

- Coordinates HSS activities through the G1.
- Coordinates and synchronizes HSS operations with assistance from the DMOC of the DISCOM. This includes coordination of corps HSS to the division.

(2) Area medical support:

Ž Medical companies provide HSS on an area support basis.
 Ž Patient holding (up-to 20 patients at each FSMC and 40 patients at the main support medical company (MSMC) is provided by the medical companies of the DISCOM.

Ž Evacuation policy for the division is 72 hours unless otherwise directed.

- Sick call schedules will be published for each operation.

Ž Contaminated casualties are decontaminated prior to entering the medical treatment facility (MTF) where treatment is provided.

Ž Each battalion aid station (BAS) and division clearing station (DCS) establishes a patient decontamination site at the MTF.

Ž Patient decontamination is performed at each MTF by the patient decontamination team (eight nonmedical personnel working under medical supervision).

(3) Dental services. Emergency and sustaining dental care is available at all medical companies.

(4) Division mental health.

Ž Psychiatric services are provided division-wide by the division mental health section (DHMS), and MSMC, MSB.

Ž Combat stress control (CSC) activities focus on prevention, triage, and treatment of stress casualties.

Ž Battle fatigue casualties (BFCs) are treated as far forward as possible.

- Neuropsychiatric patients are not evacuated from the division until seen by the division psychiatrist or his designated representative.

(5) Optometry services. Limited optometry care (eye examination, refractions, and single-vision spectacle assembly and repair) is available at the MSMC.

f. HHS—Logistics.

(1) Each medical platoon assigned to combat and CS units deploys with complete class VIII combat ASL (two DOS).

(2) Each medical company maintains three DOS of class VIII or the amount of class VIII required to support operational contingencies.

(3) Division medical supply office (DMSO) maintains five DOS of class VIII or those amounts required to support operational contingencies.

(4) The DMSO operates a unit distribution system and coordinates transportation for routine delivery of medical resupplies through the support operations section, MSB, as required.

(5) Emergency class VIII resupply is coordinated through the DMOC.

(6) The DMSO manages the division’s medical maintenance program.

(7) The DMSO coordinates with the medical logistics (MEDLOG) battalion for medical resupply, medical maintenance support services, repairable exchange, or operational readiness float (ORF) equipment.

g. HHS—Medical Evacuation. Division medical evacuation assets areas follows.

(1) The primary means of medical evacuation is ground ambulance. Medical evacuation provides *en route* medical care.

(2) Maneuver units use litter bearers and organic vehicles to evacuate casualties to unit patient collecting points (PCPs). Organic ambulances evacuate patients to the BAS. Prior to evacuation, the units secure all radios, weapons, and sensitive items. The casualty retains his protective mask.

(3) Forward support medical companies preposition ambulances with the BASS of supported maneuver battalions and evacuate patients from the BASS to the supporting FSMC. Forward support medical companies may employ the ambulance shuttle system or establish ambulance exchange points (AXPs) as necessary to facilitate medical evacuation in forward areas.

(4) The MSMC provides medical evacuation support on an area support basis for the DSA and division rear areas.

h. HHS—Medical Evacuation Policy.

(1) Patient holding. The holding policy for division is 72 hours for FSB and medical support battalion (MSB) medical companies. Medical evacuation time lines for the division are established as follows:

<u>Priority</u>	<u>Category</u>	<u>Time Line</u>
1	Urgent	2 Hours or Less
1 a	Urgent Surgical	2 Hours or Less
2	Priority	4 Hours or Less
3	Routine	24 Hours or Less
4	Convenience	Situational

(2) Air medical evacuation:

- Air evacuation is used when ground evacuation is not available or is inadequate to save life, limb, or eyesight.

Ž Request procedures. (Use Medical Evacuation Request in reports section.)

(3) Air evacuation by nonmedical aviation assets.

(a) Division aviation brigade assets can backhaul stabilized wounded within the division AO and may be used when—

- Ground evacuation routes are closed.
- Ground ambulance would not be effective in transporting the patient in a timely manner.

- Tactical situation requires rapid evacuation of casualties.

Ž Mass casualty situations exist.

- Medical evacuation aircraft are unavailable.

(b) Format is the standard MEDEVAC request.

(4) Ground evacuation.

(a) The primary means of medical evacuation during tactical operations is ground ambulance. An ambulance is any vehicle capable of transporting a patient on a litter undercover as care en route is being provided.

(b) Maneuver units evacuate casualties to battalion aid stations (BASs) using organic assets or resupply vehicles. Units secure all radios, weapons, and sensitive items. The patient retains his protective mask. Members of a wounded soldier's unit will not escort a wounded member of the unit to an aid station without the expressed verbal permission of his immediate supervisor or leader.

(c) Contaminated casualties will be decontaminated as far forward as possible by nonmedical personnel.

(d) FSB medical companies station ambulances with supported maneuver battalions BAS and evacuate patients from the BAS to the supporting medical company. Ambulance exchange points are established between the maneuver battalion aid station and the BSA medical company for patient transfer.

(e) MSB medical company provides area support evacuation for the DSA and division rear area and assets to the FSB medical companies.

(f) Corps assets evacuate patients from medical companies to corps medical facilities.

(5) Return to duty (RTD):

- RTD should process through replacement channels whenever possible.

Ž Parent unit transports RTD patients or coordinates their transportation.

- RTDs outside the division area process through AG channels.

i. *HHS—Preventive Medicine.*

(1) Unit field sanitation teams are established to perform preventive medicine measures.

(2) Food service: Units operating mobile kitchen trailers (MKTs) or other field kitchens maintain operations according to sanitation or hygiene standards outlined in TB Med 530, FM 10-23, FM 21-10-1, and FM 21-10.

(3) Potable water and ice:

- Supply: The preventive medicine section inspects all water sources and conducts random samplings. Water purification tablets are issued at class I point and are available to troops.

- Ž Distribution containers: Division preventive medicine teams routinely inspect potable water containers (for example, 400-gallon water trailers and 5-gallon containers).

- Chlorine residual concentration is maintained at 5 parts per million (ppm) and should not drop below 2 ppm at point of consumption.

- Actions during NBC operations:

- Stop all processing of potable water.

- Immediately notify the division's preventive medicine section of suspected contamination.

- Water supply specialists initiate detection procedures.

- Ž Report water sources (approved or unapproved) suspected of being contaminated to the division's preventive medicine section through G1 channels. Do not use until tested.

(4) Waste disposal:

- Contain and dispose of infectious and pathological wastes IAW AR 40-5.

- Ž Dispose of all garbage and trash according to the methods outlined in FM 21-10 and FM 21-10-1.

- Ž When committed, burial or incineration of waste is permitted.

- Human waste disposal methods are by—

- Portable latrines.

- Fixed facility latrines.

- Field latrines.

(5) Injuries and illness. Medical teams and aid stations report the following injuries and illnesses to the division surgeon immediately:

- Suspected NBC injuries.

- Any cold weather injury.

- Any heat injury.

- Ž Foodborne or suspected foodborne illness.

- Waterborne or suspected waterborne illness.

- Animal bites.

- Field site infestations (prior to pesticide application).

j. *Staff Judge Advocate.*

(1) SJA operations.

(a) The SJA establishes operations at the G1 support element at the rear CP.

(b) The SJA dedicates a judge advocate to each maneuver brigade, aviation brigade, and DISCOM.

(c) The SJA designates roving legal teams to move forward as the situation permits to provide legal services in the units and supplement brigade judge advocates.

(d) Designated JAG personnel support PMO and G5 operations.

(2) War crimes.

(a) Soldiers. Report suspected violations of the law of war to their immediate commander. When the commander is implicated in the alleged violation, report them to the commander's next superior. If this is not practical, report to the inspector general, PM, SJA, or chaplain.

(b) Commanders. Forward reports through the chain of command to the commanding general. The report must include all available information about the nature of the incident, where and when it occurred, who discovered it, and who witnessed it (with statements of witnesses and evidence).

(3) Claims and solatium payments. The SJA reviews and approves all claims and solatium payment requests to determine their legal validity and coordinates with the supporting finance unit for payment.

k. *Public Affairs.*

(1) The PAO establishes a news media center at the G1 support element at the division's rear CP.

(2) Only media accredited by the theater PAO are authorized to function within the division's AO. Any media representative violating established media ground rules will not be allowed to operate in the division AO.

(3) PAO or PAO-designated personnel will escort all media personnel, *no exceptions*.

(4) Guidelines for talking with news media personnel are if you command it, did it, or use it, then you can talk about it. If you don't want it published, don't say it. Always exercise OPSEC.

(5) Public information and OPSEC.

(a) When directed, PAO conducts OPSEC review of any material provided for release.

(b) The PAO will not conduct censorship activities of material provided for release, but will screen for OPSEC violations.

(6) Command information.

(a) The PAO operates a continuous command information program to ensure that the soldiers of the division are kept informed.

(b) Command information products (such as newspapers and newsletters) will be published and distributed on a regular basis.

1. *Chaplain Activities.*

(1) The priority of chaplain coverage is to—

- Maneuver elements.
- Casualties during combat operations.
- Survivors after combat operations.

(2) Commanders coordinate religious service schedules with chaplains.

(3) When no chaplain is assigned to a unit, the S1 requests chaplain services through the division chaplain's office at the division rear CP.

m. *Inspector General Activities.*

(1) The IG operates from the G1 support element at the rear CP.

(2) The IG maintains an open door policy for all division soldiers.

A-30. Military Police Procedures.

a. *Military Police Company.*

(1) The company HQ is initially collocated with PMO operations at the rear CP.

(2) MP platoons will be either in direct support or general support to division tactical operations.

Priority of employment of GS platoons is to area security in the division rear area, level II reaction force to the division rear CP, law enforcement, and operation of the division central EPW collection point.

b. *Division Provost Marshal's Office.* Forward all requests for MP support (and CID support) through the PMO operations section located in division rear CP.

c. *Enemy Prisoners of War Operations.*

(1) The PMO establishes a centralized point for EPW collection in the division's rear area. It is normally operated by general support MP platoons. Forward collection points are operated by brigade personnel.

(2) Capturing units tag all EPWs and their property using DA Form 5976 and evacuate to the designated collection point.

(3) Military police escort EPWs from the brigade support areas to the division or corps collection point.

A-31. Civil-Military Procedures.

a. *Civil Military Operations Center.*

(1) The CMOC is operated by G5 at the division's rear CP.

(2) It is the NCS for the CMOC (FM) net.

(3) The CMOC employs and controls all attached or OPCON supporting civil affairs teams and elements.

b. Military tactical requirements have priority over civil requirements.

c. Unit commanders will designate a member of their staff to serve as the unit S5.

SECTION IV. REPORTS

A-32. General.

a. This section contains those reports and prescribed formats which all elements in the division routinely use. Reports exist to support the commander with his critical information requirements. *Reports that are not tied to a fixed schedule may be submitted by specific request or by exception.* Reports by exception require the commander to submit a report only when the status of a significant event or element is changed that either increases or decreases the combat capability of that unit.

b. Each report has a prescribed format to ensure the completeness of the information reported. Users are reminded, however, that in fast moving tactical situations, timely reporting, especially of enemy activity, is critical. Do not delay reports only to ensure correct format— *report accurate information in a timely manner!*

(1) The time zone used for all reports is local, unless specified otherwise.

(2) All color codes use the following criteria:

- Green: 80 percent or better on hand—full strength.
- Ž Amber: 60 to 79 percent on hand—mission capable/minor deficiencies.
- Ž Red: 40 to 59 percent on hand—marginally mission capable/major deficiencies.
- Black: 39 percent or less on hand—not mission capable.

(3) Standardized report formats for the division are as follows:

(a) *Operations (blue reports)*

- Blue 1—Spot report (SPOTREP)
- Blue 2—Commander's situation report (SITREP)

(b) *Intelligence (green reports)*

- Green 1—Intelligence summary (INTSUM)
- Green 2—Periodic intelligence report (PERINTREP)
- Green 3—Weather forecast (WXFCST) report

(c) *Logistics (yellow reports)*

- Yellow 1—Logistics spot report
- Yellow 2—Equipment status report
 - Reportable lines needed in yellow 2 report
- Yellow 3—Ammunition request
- Yellow 4—POL request

(d) *Personnel (red reports)*

- Red 1—Personnel daily summary
- Red 2—Personnel battle loss report

(e) *As required reports*

- Aerial resupply/request
- Bridge report (BRIDGEREP)
- Closing report
- Cross report (CROSSREP)
- Medical evacuation request
- MIJI report (MIJIREP)
- Minefield report
- Movement report
- Patrol report
- EPW or captured material report
- Ration request
- Route reconnaissance report
- Severe weather warning (SVRWXWARN) report
- Shell report (SHELREP)
- Splash report

(f) *NBC reports*

- NBC 1—Observer's initial report
- NBC 2—Evaluated data report
- NBC 3—Immediate warning of expected contamination
- NBC 4—Report of radiation dose-rate measurement
- NBC 5—Report of areas of contamination
- NBC 6—Detailed information of chemical or biological attack(s)
- Effective downwind message
- NUCWARN message
- CHEMWARN message

REPORT TITLE	FORMAT ON PAGE	SUBMITTED BY:	SUBMIT TO:	SUBMIT AS OF:	SUBMIT NLT:	METHOD OF TRANSMISSION	PRECEDENCE
SPOT REPORT (BLUE 1)	91	MSC	G3/G2	AS NECESSARY OR UPON FIRST CONTACT OR SPOTTING	NA	FM MSE FAX	FLASH
COMMANDERS SITUATION REPORT (SITREP) (BLUE 2)	93	MSC	"G3: COMMITTED UNITS SUBMIT TO TAC CP"	AS NECESSARY	NA	MSE FM	IMMEDIATE FAX
INTELLIGENCE SUMMARY (INTSUM) GREEN 1	95	CORPS/DIV	MSC "92"	0200 1400	0400 1600	LAP TOP FAX MSE COURIER	IMMEDIATE
PERIODIC INTEL REPORT (PERINTREP) GREEN 2	96	MSC	G2	AS NECESSARY	NA	MSE FM FAX	IMMEDIATE
WEATHER FORECAST (WXPCST) GREEN 3	97	G2	MSC	0500 1700	0600 1800	FAX MSE	IMMEDIATE
LOGISTICS SPOT REPORT YELLOW 1	98	MSC	DISCOM	AS REQUIRED	NA	FAX MSE FM	PRIORITY
EQUIPMENT STATUS REPORT YELLOW 2	99	MSC "S4" (thru FSB)	0900	DMMC 1600	0800 1700	FAX MSE LAP TOP FM	IMMEDIATE
AMMO REQUEST YELLOW 3	102	MSC "S4" (thru FSB)	DISCOM	0800 1600	0900 1700	FAX MSE LAP TOP FM	IMMEDIATE
POL REQUEST YELLOW 4	105	MSC "S4" (thru FSB)	DISCOM	0800 1600	0900 1700	FAX MSE LAP TOP FM	IMMEDIATE
PERSONNEL DAILY SUMMARY RED 1	106	MSC	G1	2000	2100	FAX MSE LAP TOP FM	IMMEDIATE
PERSONNEL BATTLE LOSS REPORT RED 2	MSC	MSC	G1	AS REQUIRED		FAX MSE FM	PRIORITY
AERIAL RESUPPLY REQUEST	106	MSC	G3/AIR	AS REQUIRED		FAX MSE COURIER FM	IMMEDIATE
BRIDGE REPORT	109	MSC	ACE	AS REQUIRED		FAX MSE COURIER	IMMEDIATE
CLOSING REPORT	109	MSC	G3	AS REQUIRED		FAX MSE FM	IMMEDIATE
MEDICAL EVACUATION REQUEST	111	REQUESTING UNIT	DIV SURG	AS REQUIRED		FM MSE	FLASH

Reports matrix

REPORT TITLE	FORMAT ON PAGE	SUBMITTED BY:	SUBMIT TO:	SUBMIT AS OF:	SUBMIT NLT:	METHOD OF TRANSMISSION	PRECEDENCE
MIJI REPORT	112	MSC	G2	AS REQUIRED		FM MSE	IMMEDIATE
MINEFIELD REPORT	113	MSC	ACE	AS REQUIRED		MSE FAX FM	IMMEDIATE
MOVEMENT REPORT	114	MSC	G3	AS REQUIRED		FM MSE	IMMEDIATE
PATROL REPORT	115	MSC	G2	AS REQUIRED		FAX MSE FM	IMMEDIATE
EPW CAPTURE	116	MSC	G2	AS REQUIRED		MSE FAX FM	IMMEDIATE
ROUTE RECONNAISSANCE REPORT	117	UNIT TASKED	G3 & G2	AS REQUIRED		FM MSE	IMMEDIATE
SEVERE WEATHER WARNING REPORT	118	G2	MSC	AS REQUIRED		FMX MSE	PRIORITY
SHELL REPORT	119	MSC	FSE	AS REQUIRED		FAX MSE FM	IMMEDIATE
SPLASH REPORT	120	MSC	G3	AS REQUIRED		FM MSE FAX	IMMEDIATE
NBC 1 OBSERVERS INITIAL REPORT	121	MSC	DIV CHEM	AS REQUIRED		FM MSE	FLASH (FIRST ATTACK)
NBC 2 EVALUATED DATA REPORT	122	DIV CHEM	CORPS, MSC	AS REQUIRED		MSE FM FAX	IMMEDIATE
NBC 3 IMMEDIATE WARNING OF EXPECTED CONTAMINATION	123	DIV CHEM	MSC & CORPS	AS REQUIRED		MSE FM FAX	IMMEDIATE
NBC 4 REPORT OF RADIATION DOSE RATE	123	MSC	DIV CHEM	AS REQUIRED		MSE FM	IMMEDIATE
NBC 5 REPORT OF AREA	124	DIV CHEM	MSC & CORPS	AS REQUIRED		MSE FM	IMMEDIATE
NBC 6 DETAILED INFORMATION OF CHEMICAL AND BIOLOGICAL ATTACKS	125	DIVISION	CORPS	AS REQUIRED		FAX LAP TOP MSE	PRIORITY
EFFECTIVE DOWNWIND MESSAGE	126	DIV CHEM	MSC	AS REQUIRED		MSE FAX LAP TOP FM	IMMEDIATE
NUCWARN MESSAGE	127	DIV CHEM	MSC	AS REQUIRED		MSE FM	IMMEDIATE
CHEMWARN	128	DIV CHEM	MSC	AS REQUIRED		MSE FM	IMMEDIATE

Reports matrix (continued)

A-33. Blue Reports (Operation).

a. *Blue 1—Spot Report.*

(1) When Used. The SPOTREP is used by all units when observing any known or suspected enemy activity or when observing any characteristic of the AO likely to affect accomplishment of the mission. It is submitted through both operations and intelligence channels. SPOTREPs take priority over all other routine radio traffic. As a minimum, SPOTREP is submitted on—

- Ž First enemy contact.
 - A break in contact.
 - Contact with a new enemy unit or equipment.
- Ž Significant change in tactical situation.
- Ž Unusual or unexplained activity.
 - Enemy reconnaissance activity.
 - Any rear activity requiring Level I, II, or III response.
- Ž Indications of enemy NBC activity.
 - Significant enemy ADA, aviation, or engineer activity.
- Ž Indication that the enemy is changing its present course of action.
- Ž Other enemy and friendly activity as deemed significant.

(2) Format.

SPOTREP

Line 1: Who is observer or source: _____
 (Omit if calling station; use call signs or description otherwise.)

Line 2: What is observed: size, activity, location, unit, time, and equipment (S-A-L-U-T-E)

Size: _____
 (The number of sighted personnel and or vehicles.)

Activity: _____
 (What the enemy is doing.)

Location: _____
 (Grid or reference from a known point.)

Unit: _____
 (Patches, signs, or markings.)

Time: _____
 (The time the activity was observed.)

Equipment: _____
 (Describe or identify all equipment associated with the activity.)

Line 3: What are or were your actions or what do you recommend: _____

b. *Blue 2—Commander’s Situation Report.*

(1) When Used. The SITREP is submitted by subordinate units to the G3 to report changes to their tactical situation and status. Situation reports are submitted after or during significant events when combat capability changes or as requested. Committed units in contact with the enemy submit the

SITREP to the TAC CP. All others submit them to the main CP. Detailed yellow and red reports submitted by the unit support logistics and personnel assessments.

(2) Format.

COMMANDER'S SITREP

Line 1: Unit submitting report: _____

Line 2: Date-time group of report: _____

Line 3: Brief summary of unit activity: _____

Line 4: Enemy activity/intentions: _____

Line 5: Communications status: (G) (A) (R) (B)

Line 6: Commander evaluation:

- a. Current: (G) (A) (R) (B)
- b. Projected: (G) (A) (R) (B) *(as of change)*

Line 7: Unit status:

Unit	Status	CB	M	A	C	I	AB	AA	Center of Mass
a. _____		/	/	/	/	/	/	/	_____
b. _____		/	/	/	/	/	/	/	_____
c. _____		/	/	/	/	/	/	/	_____
d. _____		/	/	/	/	/	/	/	_____
e. _____		/	/	/	/	/	/	/	_____
f. _____		/	/	/	/	/	/	/	_____
g. _____		/	/	/	/	/	/	/	_____
h. _____		/	/	/	/	/	/	/	_____
i. _____		/	/	/	/	/	/	/	_____

Line 8: CP/Helipad location:

- a. TAC CP _____ / _____
- b. Main CP _____ / _____
- c. Rear CP _____ / _____

Line 9: FLOT: _____

Line 10: Battle resources:

	<i>Resource</i>	<i>Color</i>	<i>Auth</i>	<i>/</i>	<i>Opnl</i>
a.	_____	_____	_____	/	_____
b.	_____	_____	_____	/	_____
c.	_____	_____	_____	/	_____
d.	_____	_____	_____	/	_____
e.	_____	_____	_____	/	_____
f.	_____	_____	_____	/	_____
g.	_____	_____	_____	/	_____
h.	_____	_____	_____	/	_____
i.	_____	_____	_____	/	_____
j.	_____	_____	_____	/	_____
k.	_____	_____	_____	/	_____
l.	_____	_____	_____	/	_____

Line 11: Commander's remarks: _____

A-34. Green Reports (Intelligence).

a. *Green 1—Intelligence Summary.*

(1) Purpose. The INTSUM is used to provide the division G2 with intelligence summaries that cover 12 hours of enemy activity. Items prescribed in the format are used when needed.

(2) Format.

INTSUM

Line 1: Issuing unit: _____
 (Always included.)

Line 2: Time of issue: _____
 (Date-time group.)

Line 3: Summary of enemy activity:

- | | | |
|------------------------|--------------------|-------------------------|
| a. Enemy Unit: ***** | / | DTG: ***** |
| Center of Mass: | CP Lot: | Activity: |
| Unit Strength Percent: | Direction: | Time to Commitment: Hrs |
| Proj Mission: | Proj Obj/Approach: | / |
| b. Enemy Unit: ***** | / | DTG: ***** |
| Center of Mass: | CP Lot: | Activity: |
| Unit Strength Percent: | Direction: | Time to Commitment: Hrs |
| Proj Mission: | Proj Obj/Approach: | / |
| c. Enemy Unit: ***** | / | DTG: ***** |
| Center of Mass: | CP Lot: | Activity: |
| Unit Strength Percent: | Direction: | Time to Commitment: Hrs |
| Proj Mission: | Proj Obj/Approach: | / |
| d. Enemy Unit: ***** | / | DTG: ***** |
| Center of Mass: | CP Lot: | Activity: |
| Unit Strength Percent: | Direction: | Time to Commitment: Hrs |
| Proj Mission: | Proj Obj/Approach: | / |

Line 4: Known enemy personnel and equipment losses:

- a. Personnel, KIA: _____
- b. Enemy prisoners of war: _____
- c. Equipment destroyed or captured: _____

Line 5: Remarks/comments: _____

b. *Green 2—Periodic Intelligence Report.*

(1) Purpose. This report is used by MSC intelligence personnel to report timely combat enemy information to the division G2 without having to complete a Green 1.

(2) Format.

PERINTREP

- Line 1: Transmission time: _____
(Date-time group of transmission. Use only if directed.)
- Line 2: _____
(Time activity occurred: date-time group.)
- Line 3: Identification: _____
(Size, activity, and unit observed.)
- Line 4: At _____ : _____
(Location: best grid or reference to known points.)
- Line 5: Narrative: _____
(Equipment, uniform, markings, insignia, and anything thought significant about the sighting.)

c. *Green 3—Weather Forecast Report.*

(1) Purpose. This report is used to report weather and light data.

(2) Format.

WXFCST

Line 1: Location: _____
(Center of forecasted weather.)

Line 2: Valid: _____
(Date-time group forecast is effective.)

Line 3: Until: _____
(Date-time group forecast is no longer in effect.)

Line 4: Ceiling: _____
(Lowest forecast ceiling in hundreds of feet above ground level.)

Line 5: Cover: _____
(Total sky coverage in eighths.)

Line 6: Visibility: _____
(Prevailing visibility in meters.)

Line 7: Weather _____
(Weather phenomena being forecasted.)

Line 8: Maximum temperature: _____
(Maximum temperature in degrees Celsius.)

Line 9: Minimum temperature: _____
(Minimum temperature in degrees Celsius.)

Line 10: Freeze level: _____
(Minimum freezing level in thousands of feet. Transmitted only when appropriate.)

Line 11: Wind: _____
(Direction of variable wind direction in degrees.)

Line 12: Speed: _____
(Wind speed in knots.)

Line 13: Gusts: _____
(Peak gusts in knots.)

Line 14: Altimeter: _____
(Altimeter setting in hundredths of inches of mercury. Transmitted only when appropriate.)

Line 15: Wind direction at 2,000, 4,000, and 6,000 feet: _____
(Transmitted only when appropriate.)

Line 16: Light data and narrative: _____

Line 17: Transmission time: _____
(Date-time group of transmission. Use only if directed.)

Line 18: Authorization: _____
(Message authorized according to current guidelines. Use only if directed.)

A-35. Yellow Reports (Logistics).

a. *Yellow 1—Logistics Spot Report.*

(1) *Purpose.* This report is sent through logistics channels as losses occur to provide CSS personnel with *immediate* personnel and equipment losses. The personnel and equipment reported on the Yellow 1 are assumed to be incapable of performing combat missions. Units will report attachments, but not detached units.

(2) *Format.*

LOGISTICS SPOTREP

Line 1: Reporting unit: _____

Line 2: DTG of report: _____

Line 3: Equipment losses

	Type Equip	Loss	Onhand
a.	_____	_____	_____
b.	_____	_____	_____
c.	_____	_____	_____
d.	_____	_____	_____

Line 4: Personnel losses

	Position	Loss
a.	_____	_____
b.	_____	_____
c.	_____	_____
d.	_____	_____

Line 5: Significant supply losses

	Class	Loss
a.	_____	_____
b.	_____	_____
c.	_____	_____

Line 6: Combat capability of unit

G A R B

b. *Yellow 2—Equipment Status Report.*

(1) *Purpose.* This report is submitted through supporting MSB or FSB to the DMMC by MSC S4 personnel. The DMMC consolidates the data and provides the status of mission essential equipment to the G4. Changes are forwarded immediately upon loss of equipment.

(2) *Reportable Lines Needed in Yellow 2 Report.*

- (a) When the entire combat system is a combat loss, report the numerical line.
- (b) When a subsystem is a combat loss, report the numeric-alpha line of the subsystem only.

(c) Report combat loss of communications subsystems by the appropriate numeric-alpha line.
 (3) Format.

EQUIPMENT STATUS REPORT

Unit provides data pertaining to critical equipment to division G4.

Line 1: Unit: _____

Line 2: DTG of report: _____

Line 3:

	(1) <i>Item</i>	(2) <i>Line #</i>	(3) <i># Authorized</i>	(4) <i># On Hand</i>	(5) <i># NMC</i>	(6) <i>Total Operational</i>	(7) <i>Color Status</i>
a.	_____	_____	_____	_____	_____	_____	_____
b.	_____	_____	_____	_____	_____	_____	_____
c.	_____	_____	_____	_____	_____	_____	_____
d.	_____	_____	_____	_____	_____	_____	_____
e.	_____	_____	_____	_____	_____	_____	_____
f.	_____	_____	_____	_____	_____	_____	_____
g.	_____	_____	_____	_____	_____	_____	_____
h.	_____	_____	_____	_____	_____	_____	_____
i.	_____	_____	_____	_____	_____	_____	_____
j.	_____	_____	_____	_____	_____	_____	_____

Line 4: Commander's overall assessment: (G) (A) (R) (B)

Line Number Nomenclature/Model

Missile Systems:

- 1 TOW M220 (Ground)
- 2 TOW M65 (Air)
- 3 Dragon M47
- 4 Stinger
- 5 _____

Weapons Systems:

- 6 Howitzer, 105 mm, M102 M119
- 7 Howitzer, 155 mm, M198
- 8 Mortar, 81 mm
- 9 Mortar, 60 mm
- 10 Machine Gun, 7.62 mm, M60
- 11 Machine Gun, 5.56 mm, M279
- 12 Gun, 20 mm, ADA, M167

Line Number

Nomenclature/Model

Tactical Vehicles/Trailers:

13	Trk, Cgo,5T, M928
14	Trk, Trac,5T, M9311
15	Trk, Wrecker, 5T, M936.
16	Trk, Cgo, HMMWV, M998
17	Trk, Armd HMMWV, M1025
18	Trk, Amb, HMMWV, M997
19	Trk, HMMWV, TOW, M966
20	Trk, Shelter, HMMWV, M1037
21	Semitrl, 22T, M871
22	Trl, Flat Bed 15T
23	Trl, 1-1/2T Ammo
24	Trl, 1-1/2T Cgo
25	Trl, 400 Gal, Water
26	Trl, 3/4T Cgo
27	Armd Cbt Excav (ACE) M9
28	Small Equip Excav (SEE)
29	Forklift, 6000 1b
30	Forklift, 4000 1b

Communications/Electronics:

31	Radio
a	AN/GRC-106 or 213
b	AN/GRC-160 or 88
c	AN/VRC-46 or 90
d	AN/VRC-47 or 89
e	AN/VRC-64 or 87
f	AN/VRC-49 or 92
g	AN/VRC-77 or 119
h	AN/VRC-12
i	AN/VRC-3
j	Fax
k	MSRT
l	DNVT
m	TCP/AC
n	TACFIRE
32	GSR, AN/PPS-15
33	AN/TRQ-32, Teammate
34	AN/TRQ-30, Rad Rec
35	AN/TPQ-36, Firefinder

Aircraft:

36	Helicopter, atk, AH-64
a	Gun, 30 mm
b	Missile, Hellfire
c	Rocket, 2.75
37	Helicopter, atk, AH-1S
a	Gun, 20 mm
b	Missile, TOW
c	Rocket, 2.75

<u>Line Number</u>	<u>Nomenclature/Model</u>
38	Helicopter, OH-58D
a	Mast Mounted Sight
39	Helicopter, OH-58C
40	Helicopter, UH-60
41	Helicopter, UH-1H
42	Helicopter, EH-60/EH-1

c. *Yellow 3—Ammunition Request.*

(1) Purpose. This report provides routine requests for specific types of ammunition through logistics channels. Units submit Yellow 3 reports through FSB or MSB to the division ammunition office. All quantities listed will be quantity required unless otherwise requested. Line or number designators are as follows.

(2) Format.

AMMUNITION REQUEST

<u>Line Number</u>	<u>Nomenclature</u>	<u>Quantity Required</u>
Small Arms		
1	5.56 Ball	—
2	5.56 Tracer	—
3	5.56 Linked 4-1	—
4	7.62 Linked 4-1	—
5	9-mm Ball	—
6	40-mm HEDP	—
7	40-mm Illum	—
8	40-mm Smoke Color	—
9	50-cal Linked 4-1	—
10	20-mm Linked for Vulcan	—
11	40-mm Linked HEDP	—
12	_____	—
13	_____	—
Mortars:		
14	60-mm Illum	—
15	60-mm HE	—
16	60-mm WP	—
17	81-mm Illum	—
18	81-mm HE	—
19	81-mm WP	—
20	_____	—
21	_____	—
22	_____	—
105-mm Howitzer:		
23	HE w/o Fuze	
24	HEPT WF BD	
25	Illum WF MT	

<u>Line Number</u>	<u>Nomenclature</u>	<u>Quantity Required</u>
26	Smk WF MT	—
27	HCBE WF MT	—
28	HE ICM WFMT	—
29	Smk w/o Fuze	—
30	APERS WF MT	—
31	Fuze MT	—
32	Fuze MTSQ	—
33	Fuze PD	—
33	Fuze Prox	—
155-mm Howitzer:		
34	HE APIC	—
35	HE DPICM	—
36	HE RAP	—
37	HE w/o Fuze	—
38	ADAM	—
39	RAAM	—
40	HCBE	—
41	Illum	—
42	Copperhead	—
43	WP	—
44	Chg White Bag ER	—
45	Chg Green Bag	—
46	Chg White Bag	—
47	Reducer Flash	—
48	Fuze MTSQ	—
49	Fuze PD	—
50	Fuze Prox	—
51	Primer	—
Aircraft:		
52	7.62 linked 4-1	—
53	20-mm linked 4-1	—
54	30-mm linked	—
55	2.75 Rocket HE	—
56	2.75 Rocket WP	—
57	2.75 Rocket Illum	—
58	2.75 Rocket Flechett	—
59	2.75 Rocket Smk	—
60	Missile TOW	—
61	Missile Hellfire	—
62	Helicopter Mine Disp Reload	—
Grenades:		
63	Fragmentary	—
64	Incendiary	—
65	CS	—
66	Smk HC	—
67	Smk Green	—

<u>Line Number</u>	<u>Nomenclature</u>	<u>Quantity Required</u>
68.....	SmkYellow	—
69.....	Smk Violet	—
70.....	Smk Red	—
71.....	_____	—
72.....	_____	—
Rocket/Missile:		
73.....	66-mmHeat(LAW)	—
74.....	66-mm Incendiary (M202)	—
75.....	Dragon	—
76.....	TOW	—
77.....	Stinger	—
Mines:		
78.....	APERS, M16	—
79.....	APERS, M3	—
80.....	APERS, M14	—
81.....	APERS, M18	—
82.....	APERS, M26	—
83.....	AT, M15	—
84.....	AT, M19	—
85.....	AT, M21	—
86.....	AT, M24	—
87.....	M74/75 (Volcano)	—
Demolitions:		
88.....	Chg, C-4,1 1/4 lb	—
89.....	Chg, Flex-X, M118	—
90.....	Demo Kit, Bangalore	—
91.....	Chg, TNT, 1/4 lb	—
92.....	Chg,TNT, 1/2 1b	—
93.....	Chg, TNT, 1 lb	—
94.....	Chg, Satchel, 20 lb	—
95.....	Chg, Cratering 40 lb	—
96.....	ElecCaps	—
97.....	Nonelec Caps	—
98.....	Expl, Destructor	—
99.....	Demo Kit, Cratering M110	—
100.....	Coupling Base, w/Primer	—
101.....	Chg, Demo Shape 15 lbs	—
102.....	Chg, Demo Shape 40 lbs	—
103.....	Chg, Demo Kit,Proj Chg M17	—
104.....	Det Cord	—
105.....	Military Dynamite	—
106.....	Firing Device, Pressure Release	—
107.....	Firing Device, Pull Friction	—
108.....	Firing Device, Pull Release	—
109.....	Time Fuze	—
110.....	Igniter, Time Fuze	—

<u>Line Number</u>	<u>Nomenclature</u>	<u>Quantity Required</u>
111	Document Destroyer	—
112	Crater Kit, M180	—

Signal Devices:

113	Pers Distress Flare	—
114	Sig, Illum WSC	—
115	Sig, Illum RSP	—
116	Sig, Illum WSP	—
117	Sig, Illum GSC	—
118		—
119		—

d. *Yellow 4—POL Request.*

(1) Purpose. This report is used to conduct routine requests for specific types and quantity of class III items through the FSB and MSB to the DMMC class III section. The following line or number designators will be used.

(2) Format.

POL REQUEST

<u>Line Number</u>	<u>Nomenclature</u>	<u>U/L</u>	<u>Quantity Required</u>
1	Report as of DTG:		
2	MOGAS	gal	—
3	Diesel	gal	—
4	Oil, OE-10	gal	—
5	Oil, OE-30	gal	—
6	Oil, OE-50	gal	—
7	Antifreeze	gal	—
8	Starter Fluid	gal	—
9	De-icing Fluid	gal	—
10	Brake Fluid	gal	—
11	Hydraulic Fluid OHA	qt	—
13	Hydraulic Fluid OHT	qt	—
14	Hydraulic Fluid FRH	qt	—
15	Oil, Penetrating	qt	—
16	Oil, PL-Special	qt	—
17	Oil, PL-Med	qt	—
18	Bore Cleaner	gal	—
19	Oil, LSA	qt	—
20	Anti-seize comp C-122 1/2 lb	cn	—
21	Grease, GAA	lb	—
22	Grease, Wheel Bearing	lb	—
23	Solvent	gal	—
24	Sealer, Gasket	cn	—
25	Fog Oil	barrel	—

A-36. Red Reports (Personnel).

a. *Red 1—Personnel Daily Summary.*

(1) Purpose. Red 1 Personnel Daily Summary is a hasty personnel report transmitted daily as of 2000 hours to the G1 to monitor personnel combat strength as availability occurs. Report only those lines that have changed during the report period. Units will report attachments, but not detached units. A complete personnel status report (DA Form 5367-R) is submitted when sufficient information is available to determine personnel requirements.

(2) Format.

PERSONNEL DAILY SUMMARY

Line 1: Report as of date-time group: _____

Line 2: Unit: _____

Line #	Auth	Asgd	PDY	KIA	WIA	MIA	NON COMBAT LOSES	TOTAL LOSSES	GAINS	REMARKS
3. Commissioned										
4. Warrant										
5. Enlisted										

Line 6: Unit personnel status: (G) (A) (R) (B)

b. *Red 2—Personnel Battle Loss Report.*

(1) Purpose. This report is transmitted to the G1 as the casualty occurs. Unit will also complete DA Form 1156 with witness statements DA Form 1155 delivered to G1 daily. Red 2 is a interim report to update data sent on the last Red 1.

(2) Format.

PERSONNEL BATTLE LOSS REPORT

Line 1: Unit manning report (UMR) position number or encoded grade, MOS, and quantity: _____

Line 2: Date-time group of incident: _____

Line 3: Location (encoded): _____

Line 4: Type casualty:

a. KIA hostile action: _____

b. KIA nonhostile: _____

c. Body recovered: _____

d. Body not identified: _____

e. Body identified: _____

- f. Body not identified: _____
- g. MIA: _____
- h. Captured: _____
- i. WIA hostile: _____
- j. WIA nonhostile: _____
- k. Accident: _____

Line 5: Evacuated to: _____

A-37. As Required Reports.

a. Aerial Resupply Request.

(1) Purpose. This request is submitted to program aircraft for routine resupply missions using division and corps assets.

(2) Format.

AERIAL RESUPPLY REQUEST

Line 1: Unit supported: _____

Line 2: Types and quantities of supplies desired: _____
(Include description of supplies, e.g., 200 rds of 155-mm HE.)

Line 3: Priority of supplies: _____

Line 4: Requested time for drop: _____

Line 5: Exact location: _____
(Encoded 6-digit map coordinate.)
ONE—Primary DZ or LZ.
TWO—Alternate DZ or LZ.
THREE—Leading friendly unit or FEBA (trace by at least 2 points).

Line 6: Brief description of: _____
ONE—Primary DZ, size and long axis.
TWO—Alternate DZ, including size and long axis.

Line 7: Recent/significant enemy activity in delivery area: _____

Line 8: Terrain characteristics which may: _____
ONE—Interfere with the approach or exit flight pattern.
TWO—Interfere with the identification of the DZ or LZ.
THREE—Serve as checkpoints.

Line 9: Primary call sign and frequency: _____

Line 10: Alternate call sign and frequency: _____

Line 11: Signal to be used when DZ or LZ is unsafe: _____

Line 12: Recommended method of delivery: _____

- ONE—Parachute.
- TWO—Airdrop.
- THREE—Air-land.

Line 13: Cancel request if not completed by: _____
(Date-time.)

b. *Report for Bridge, Overpass, Culvert, or Causeway (BRIDGEREP).* The format is as follows:

BRIDGEREP

Line 1: Type and location: _____

Line 2: Overall length: _____

Line 3: Width of roadway: _____

Line 4: Height restriction: _____

Line 5: Type and location: _____

Line 6: Length of spans and number: _____

Line 7: Computed class: _____

Line 8: Bypass: _____
(Easy or difficult.)

c. *Closing Report.*

(1) Purpose. The terms “closing” or “closed” indicate that the main body has arrived at the destination. A final Closing Report is rendered for trail parties and disabled vehicles.

(2) Format.

CLOSING REPORT

Line 1: Unit designation of closing unit: _____

Line 2: Unit’s new location: _____

Line 3: Date-time group main body closed: _____

Line 4: Explanation of accidents/incidents: _____
(Who, what, where, when, how, and additional information if applicable.)

Line 5: Estimated date and time of arrival trail party and/or disabled vehicles: _____

d. *Report for Ford, Ferry, or Other Crossing Site (CROSSREP).* The format is as follows:

CROSSREP

Line 1: Type and location: _____

Line 2: Length of crossing: _____

Line 3: Usable width: _____

- Line 4: Current: _____
(In meters/sec _____.)
- Line 5: Maximum depth: _____
(In meters.)
- Line 6: Bottom material and condition: _____
- Line 7: If ferry has existing equipment: _____
(Capacity in tons.)
- Line 8: Slope of entry bank: _____
- Line 9: Slope of far bank: _____
- Line 10: Other comments: _____

e. Medical Evacuation Request.

(1) Purpose. Medical evacuation request is a request from medical personnel or the senior person present.

(2) Format.

MEDICAL EVACUATION REQUEST

- Line 1: Location of pickup site: _____
- Line 2: Radio frequency, call sign, and suffix: _____
- Line 3: Number of patients by category: _____
 - A—Urgent.
 - B—Urgent Surgical.
 - C—Priority.
 - D—Routine.
 - E—Convenience.
- Line 4: Special equipment required: _____
 - A—None.
 - B—Hoist.
 - C—Extraction equipment.
 - D—Ventilator.
- Line 5: Number of patients by type: _____
 - L—Litter.
 - A—Ambulatory.
- Line 6: Security of pickup site: _____
 - N—No enemy troops in area.
 - P—Possible enemy troops in area (approach with caution),
 - E—Enemy troops in area (approach with caution).
 - X—Enemy troops in area (armed escort required).
- Line 7: Method of marking pickup site: _____
 - A—Panels.
 - B—Pyrotechnic signal.
 - C—Smoke signal.
 - D—None.
 - E—Other.

Line 8: Patients' nationality and status: _____

- A—US military.
- B—US civilian.
- C—Non-US military.
- D—Non-US civilian.
- E—EPW.

Line 9: NBC contamination: _____

- N—Nuclear.
- B—Biological.
- C—Chemical.

f. *MIJI Report.*

(1) Purpose. When the reception of radio signals is hindered, confused, or distorted by any external source, or instructions are received from a station that cannot authenticate, the person experiencing the problem will immediately submit a MIJI Report to the intelligence officer.

(2) Format.

MIJIREP

Line 1: Unit: _____
(Unit identification.)

Line 2: Type: _____
(Type of interference.)

Line 3: Location: _____
(Best grid or reference to known point.)

Line 4: On time: _____
(Start date-time group.)

Line 5: Off time: _____
(Off date-time group.)

Line 6: Effects: _____
(Operations/equipment affected.)

Line 7: Frequency: _____
(Frequency/frequency range.)

Line 8: Narrative: _____

Line 9: Transmission time: _____
(Date-time group of transmission. Use only if directed.)

Line 10: Authorization: _____
Message authorized according to current guidelines. Use only if directed.)

g. Minefield Report.

(1) When Used. This report is used when authorized or when requesting authorization to emplace hasty protective minefields; to report intention, initiation, and completion of laying.

(2) Format.

MINEFIELD REPORT-A (intention to lay)

- Line 1: Unit, type and number: _____
(Call sign, "hasty protective" sequentially assigned number.)
- Line 2: Coordinates of extremities (ENCRYPT): _____
- Line 3: Estimated DTG of start and completion: _____
(Send both times.)

MINEFIELD REPORT-B (initiation of laying)

- Line 1: Type and number: _____
(See Minefield Report-A, Line 1.)
- Line 2: Actual DTG of start: _____

MINEFIELD REPORT-C (completion of minefield)

- Line 1: Type and number: _____
(See Minefield Report-A, Line 1.)
- Line 2: Actual DTG of completion: _____
- Line 3: Changes to any information reported in Report-A: _____
- Line 4: Total number of mines laid by type: _____
- Line 5: Method of laying: _____
(Normally "hand-surface" or "hand-buried".)
- Line 6: Details of lanes: _____
(Specify location of gaps, entrance, exit, aximuth, type of marking, etc. ENCRYPT digits.)
- Line 7: Details of minefield: _____
(Normally "under marking observation" or "single wire fence and signs.")

h. Movement Report.

(1) Purpose. This report is to track the safe movement of units within the division. It is to be submitted by MSCs and separate battalions when a unit is exercising road movement credits.

(2) Format.

MOVEMENT REPORT

- Line 1: Unit. _____
- Line 2: SP. (Units will notify the TOC or the division command post specified in a movement order NLT 10 minutes after reaching their SP and report their SP time.)
- Line 3: RP. (Units will notify the TOC or the division command post specified in a movement order NLT 10 minutes after reaching their RP and report their RP time.)

i. Patrol Report.

(1) Purpose. This report is used to report combat information to headquarters. The duration and activity of dismounted reconnaissance patrols requires debriefing. The report ensures uniform reporting

and guarantees all significant information obtained by the patrol is reported. Only those items identified by an asterisk (*) are required to be submitted in an initial report.

(2) Format.

PATROL REPORT

*Line 1: Designation of patrol: _____

Line 2: Size and composition of patrol: _____

Line 3: Task: _____

*Line 4: Time of departure: _____

*Line 5: Time of return: _____

*Line 6: Routes: _____
(Out and back.)

Line 7: Terrain: _____
(Description of terrain—dry, swampy, jungle; conditions of bridges as to type, size, and strength; effect on armor and wheeled vehicles.)

*Line 8: Enemy: _____
(Strength, disposition, equipment, weapons, attitude, morale, exact location, movement, and any shift in dispositions. Time activity was observed. Coordinates where activity occurred.)

Line 9: Map corrections: _____

Line 10: Miscellaneous information: _____
(Including aspects of NBC warfare.)

Line 11: Results of encounters with enemy: _____
(Number of EPWs captured, disposition enemy casualties, captured documents, and captured equipment.)

Line 12: Condition of patrol: _____
(Include status of dead and wounded.)

*Line 13: Conclusions and recommendations:

Line 14: Additional remarks by debriefer:

Line 15: Distribution (optional):

j. *EPW or Captured Material Report.*

(1) Purpose. This report is used to report a prisoner or material captured that is of immediate tactical importance.

(2) Format.

EPW OR CAPTURED MATERIAL REPORT

Line 1: Captured item or EPW: _____

Line 2: Time of capture: _____
(Date-time group.)

Line 3: Place of capture: _____
(Best grid or reference to known point.)

Line 4: Capturing unit: _____
 (Call sign.)

Line 5: Circumstances of capture: _____
 (Be brief.)

Line 6: Transmission time: _____
 (Date-time group of transmission. Use only if directed.)

k. *Ration Request.*

(1) Purpose. This request is to be used by the unit when the tactical situation prohibits face-to-face coordination for rations.

(2) Format.

RATION REQUEST

Line 1: DTG of request: _____

Line 2: Requested delivery time: _____

Line 3: Number T-ration meals: _____

Line 4: Number MRE meals: _____

Line 5: Water in gallons: _____

Line 6: Coordinates of delivery or link-up point: _____

1. Route Reconnaissance Report. The format is as follows.

ROUTE RECONNAISSANCE REPORT

Line 1: From: _____

Line 2: To: _____

Line 3: What: _____

- /1—Highway
- /2—Road
- /3—Trail
- /4—Cross country

Line 4: Class route: _____

- /1—Only tracked vehicles
- /2—Any wheel vehicle
- /3—Dismounted only

Line 5: Type: _____

- /1—All weather
- /2—Limited all weather
- /3—Fair weather

Line 6: Movement possible: _____

- /1—Fast
- /2—Slow

Line 7: Any critical points: _____

m. *Severe Weather Warning Report (SVRWXWARN).*

- (1) Purpose. This report is used to report forecast severe weather data.
- (2) Format.

SVRWXWARN

- Line 1: Type: _____
(Type and name of severe weather.)
- Line 2: Location: _____
(Center of forecasted weather.)
- Line 3: Valid: _____
(Date-time group forecast is effective.)
- Line 4: Until: _____
(Date-time group forecast is no longer in effect.)
- Line 5: Weather: _____
(Atmospheric conditions with respect to cloudiness, precipitation, other weather phenomena.)
- Line 6: Visibility: _____
(Minimum visibility in meters.)
- Line 7: Ceiling: _____
(Lowest forecast ceiling in feet above ground level.)
- Line 8: Maximum speed: _____
(Maximum wind speed in knots.)
- Line 9: Gusts: _____
(Peak gusts in knots.)
- Line 10: Direction: _____
(Wind direction in degrees.)
- Line 11: Narrative: _____
- Line 12: Transmission time: _____
(Date-time group of transmission. Use only if directed.)
- Line 13: Authorization: _____
(Message authorized according to current guidelines. Use only if directed.)

n. *Shell Report (SHELREP).*

- (1) When Used. This report is used when any of the format information is requested.
- (2) Format.

SHELREP, MORTREP, BOMREP (specify)

- Line 1: Unit of origin: _____
- Line 2: Observer's location: _____
- Line 3: Azimuth to bursts, flashes: _____
(Specify which: sound, groove of shell, rocket flight path, or type of azimuth, degrees or mils.)

Line 4: DTG attack began: _____

Line 5: DTG attack ended: _____

Line 6: Location of attack grid: _____

Line 7: Number and nature of guns, mortars, aircraft, or other methods of delivery: _____

Line 8: Nature of fire, barrage, registration, etc.: _____

Line 9: Number and type and caliber of bombs, shells, rockets, etc.: _____

Line 10: Flash to bang time in seconds: _____
(Omit for aircraft.)

Line 11: Damage : _____
(If friendly personnel/equipment.)

o. Splash Report

(1) Purpose. This report is used to report downed friendly aircraft.

(2) Format.

SPLASH REPORT

Line 1: Call sign: _____

Line 2: Aircraft data: _____
(Type and status.)

Line 3: Pilot status: _____
 1—Recovered good condition
 2—Recovered WIA
 3—Recovered KIA
 4—Unknown

A-38. NBC Reports.

a. NBC 1—Observer's Initial Report. The format is as follows.

OBSERVERS INITIAL REPORT

Line 1: Strike serial number: _____
(If known. Assigned by the NBC element.)

Line 2: Position of observer: _____
(Coordinates or place.)

Line 3: Direction measured clockwise from grid north, true north, or magnetic north (state which) of the attack from observer: _____
(Degrees or mils, state which.)

Line 4: Date-time of detonation or date-time attack started: _____

Line 5: Illumination time or date-time attack started: _____

- Line 6: Linear target grids or location of attack or location of area attacked: _____
(Coordinates of place. Actual or estimated, state which.)
- Line 7: Means of delivery or kind of attack: _____
(Guns, mortars, multiple rockets, missiles, bombs, spray—state which.)
- Line 8: Type of burst (air, surface of unknown-state which) including height or type of agent, height of burst: _____

- Line 9: Number of munitions or aircraft (state which): _____
- Line 10: Flash to bang time (seconds): _____
- Line 11: Crater present or absent and diameter (meters) or description of terrain/vegetation: _____

- Line 12: Nuclear burst angular cloud width measured at H + 5 minutes: _____
(Degrees or mils, state which.)
- Line 13: Stabilized cloud-top angle and/or cloud-bottom angle (state which) or cloud-top height and/or cloud-bottom height (state which) measured at H + 10 minutes: _____
(Degrees, mils, meters, or feet—state which.)
- Line 14: Date-time of reading or date-time contamination detected: _____

- Line 15: 20 cGy/hr (rad/hr) contour line coordinates (black) or area of actual contamination (yellow): _____

b. NBC 2—Evaluated Data Report. The format is as follows.

EVALUATED DATA REPORT

- Line 1: Strike serial number: _____
(If known. Assigned by the NBC element.)
- Line 2: Date-time of detonation or date-time attack started: _____
- Line 3: Linear target grids or location of attack or location of area attacked: _____
(Coordinates of place. Actual or estimated, state which.)
- Line 4: Means of delivery or kind of attack: _____
(Guns, mortars, multiple rockets, missiles, bombs, spray—state which.)
- Line 5: Type of burst (air, surface of unknown-state which) including height or type of agent, height of burst: _____
- Line 6: Estimated Yield (KT): _____

c. NBC 3—Immediate Warning of Expected Contamination. The format is as follows.

IMMEDIATE WARNING OF EXPECTED CONTAMINATION

- Line 1: Strike serial number: _____
(If know. Assigned by the NBC element.)
- Line 2: Date-time of detonation or date-time attack started: _____

- Line 3: Linear target grids or location of attack or location of area attacked: _____
(Coordinates of place. Actual or estimated, state which.)
- Line 4: Type of burst (air, surface of unknown—state which) including height or type of agent, height of burst: _____
- Line 5: Coordinates of points to outline external contours of radioactive cloud or predicted hazard area: _____
- Line 6: Downwind direction of radioactive cloud (in degrees or mils, state which) or duration of hazard (days): _____
- Line 7: Directions measured clockwise from grid north to the left and then to the right radial lines: _____
(4 digits. Degrees or mils, state which.)
Representative downwind: _____
(4 digits. Degrees or mils, state which.)
Representative wind-speed: _____
(3 digits. Kmph or knots, state which.)

- d. *NBC 4—Report of Radiation Dose-Rate Measurement.* The format is as follows.

REPORT OF RADIATION DOSE-RATE MEASUREMENT

- Line 1: Type of burst (air, surface of unknown-state which) including height or type of agent, height of burst: _____
- Line 2: Location of reading or location where sample(s) taken and details of type of sample: _____
- Line 3: Dose rate cGy/H (rad/h) the words “initial,” “increasing,” “peak,” or “decreasing” maybe added. When decay rate is reported the words “decay normal,” “decay fast,” or “decay slow” or the actual value of decay constant maybe inserted: _____
- Line 4: Date-time of reading or date-time contamination detected: _____

- e. *NBC 5—Report of Areas of Contamination.* The format is as follows.

AREAS OF CONTAMINATION REPORT

- Line 1: Strike serial number: _____
(If known. Assigned by the NBC element.)
- Line 2: Reference date-time for estimated contours when not H + 1 hour: _____
- Line 3: Date-time of reading or date-time contamination detected: _____
- Line 4: H + 1 date-time or date-time of latest survey of contamination in the area: _____
- Line 5: 1,000 cGy/hr (rad/hr) contour line coordinates (red): _____

Line 6: 300 cGy/hr (rad/hr) contour line coordinates (green): _____

Line 7: 100 cGy/hr (rad/hr) contour line coordinates (blue): _____

Line 8: 20 cGy/hr (rad/hr) contour line coordinates (black) or area of actual contamination (yellow): _____

f. NBC 6—Detailed Information of Chemical or Biological Attack. The format is as follows.

REPORT OF CHEMICAL OR BIOLOGICAL ATTACK

Line 1: Strike serial number: _____
(Assigned by NBC element)

Line 2: Date-time attack started: _____
(Zulu-Z, Local-L or Letter Zone)

Line 3: Date-time attack ended: _____
(Zulu-Z, Local-L or Letter Zone)

Line 4: Area attacked: _____
(Location, UTM, or Place) (Actual-A, Estimated-E, state which)

Line 5: Means of delivery, if known: _____

Line 6: Type of agent and height, if known: _____

Line 7: Number of munitions or aircraft: _____

Line 8: Description of terrain/vegetation: _____

Line 9: Enemy action before and after attack, effect on troops: _____

Line 10: Location (UTM) and type of sample(s): _____

Line 11: Date-time contamination initially detected: _____
(Zulu-Z, Local-L or Letter Zone)

Line 12: Date-time of latest survey of contamination: _____
(Zulu-Z, Local-L or Letter Zone)

Line 13: Area of tactical significance of contamination (UTM): _____

A: _____

B: _____

C: _____

D: _____

(Coded yellow on overlay)

Line 14: Downwind direction: _____ Wind Speed: _____
(Degrees-D or Mils-M, state which) (Km/hr)

Line 15: Remarks: _____

g. *Effective Downwind Message*. The format is as follows.

EFFECTIVE DOWNWIND MESSAGE

- Line 1: Strike serial number: _____
(If known. Assigned by the NBC element.)
- Line 2: Date-time of detonation or date-time attack started: _____
- Line 3: Illumination time or date-time attack started: _____
- Line 4: Linear target grids or location of attack or location of area attacked: _____
(Coordinates of place. Actual or estimated, state which.)
- Line 5: Means of delivery or kind of attack: _____
(Guns, mortars, multiple rockets, missiles, bombs, spray—state which.)
- Line 6: Type of burst (air, surface of unknown—state which) including height or type of agent, height of burst: _____
- Line 7: Number of munitions or aircraft (state which): _____
- Line 8: Crater present or absent and diameter (meters) or description of terrain/vegetation: _____

- Line 9: Stabilized cloud-top angle and/or cloud-bottom angle (state which) or cloud-top height and/or cloud-bottom height (state which) measured at H + 10 minutes: _____

- Line 10: Location of reading or location where sample(s) taken and details of type of sample: _____

- Line 11: Date-time of reading or date-time contamination detected: _____
- Line 12: H + 1 date-time or date-time of latest survey of contamination in the area: _____

- Line 13: 20cGy/hr (rad/hr) contour line coordinates (black) or area of actual contamination (yellow): _

- Line 14: Directions measured clockwise from grid north to the left and then to the right radial lines: _

- (4 digits. Degrees or mils, state which.)
- Representative downwind direction: _____
- (4 digits. Degrees or mils, state which.)
- Representative wind-speed: _____
- (3 digits. Kph or knots, state which.)
- Line 15: Remarks: _____

h. *NUC WARN Message*. The format is as follows.

NUCWARN MESSAGE

- Line 1: Strike serial number: _____
(If known. Assigned by the NBC element.)
- Line 2: Date-time of detonation or date-time attack started: _____
- Line 3: Linear target grids or location of attack or location of area attacked: _____
(Coordinates of place. Actual or estimated, state which.)
- Line 4: Type of burst (air, surface of unknown-state which) including height or type of agent, height of burst: _____
- Line 5: Number of munitions or aircraft (state which): _____
- Line 6: Coordinates of points to outline external contours of radioactive cloud or predicted hazard area: _____

- Line 7: Directions measured clockwise from grid north to the left and then to the right radial lines: _____

- (4 digits. Degrees or mils, state which.)
- Representative downwind direction: _____
- (4 digits. Degrees or mils, state which.)
- Representative wind-speed: _____
- (3 digits. Kph or knots, state which.)

i. *CHEMWARN Message*. The format is as follows.

CHEMWARN MESSAGE

- Line 1: Strike serial number or code word: _____
- Line 2: Date-time group of attack: _____
- Line 3: Location of attack: _____
- Line 4: Delivery means: _____
- Line 5: Type of agent: _____
- Line 6: Attack area and predicted hazard area: _____
- Line 7: Duration of hazard: _____
- Line 8: Downwind direction and wind speed: _____

GLOSSARY

- AA** — avenue of approach; assembly area
AACG — arrival airfield control group
AATF — air assault task force
AATFC — air assault task force commander
AAV — assault amphibian vehicle
ABCCC — airborne battlefield command and control center
ABMOC — air battle management operations center
abn — airborne
A²C² — Army airspace command and control
ACA — airspace control authority
ACL — allowable cargo load
ACO — airspace control order
ACofS — assistant chief of staff
ACP — air control point
ACR — armored cavalry regiment
ADA — air defense artillery
ADC — assistant division commander
ADC-M — assistant division commander for maneuver
ADC-S — assistant division commander for support
ADCS — air defense coordination section
ADE — assistant division engineer
ADSO — assistant division signal officer
ADW — air defense warning
AFARN — Air Force air request net
AFSCoord — assistant fire support coordinator
AFSO — assistant fire support officer
AG — adjutant general
AGL — above ground level
AHB — attack helicopter battalion
AI — air interdiction
ALCE — airlift control element
ALO — air liaison officer
AM — amplitude modulation
AMB — air mission brief
AMC — at my command
ammo — ammunition
AMOPES — air mobilization and operations planning system
ANGLICO — air and naval gunfire liaison company
AO — area of operations
AOC — air operations center
AOR — area of responsibility
ARFOR — Army forces
armd — armored
arty — artillery
ASIC — all source intelligence center
ASL — authorized stockage level
aslt — assault
ASMB — medical battalion, area support
ASMC — medical company, area support
ASOC — air support operations center
ASPS — all source production section
AT — antitank
ATC — air traffic control
ATCCS — air tactical command and control system
atcd — attached
ATIZ — artillery target intelligence zone
atk — attack
ATMCT — air terminal movement control team
ATP — ammunition transfer point
ATS — air traffic service
auth — authorized
AVIM — aviation intermediate maintenance
AVLB — armored vehicle launched bridge
avn — aviation
AWACS — airborne warning and control system
AWOL — absence without leave
B — black
BAS — battalion aid station
BCOC — base cluster operations center
bale — brigade

BDOC — base defense operations center
BDU — battle dress uniform
BHL — battle hand-over line
bn — battalion
BOMREP — bombing report
BOS — battlefield operating systems
BP — battle position
BSA — brigade support area
BSFV — Bradley Stinger fighting vehicle
btry — battery
C2 — command and control
C3 — command, control, and communications
CA — civil affairs
cal — caliber
CANA — convulsant antidote nerve agent
CAPSTONE — program that aligns active component and reserve component units to meet the Total Army's wartime requirements
CAS — close air support
cav — cavalry
cbt — combat
CCIR — commander's critical information requirements
CCT — combat control team
CDR — commander
CDS — container delivery system
CEWI — combat electronic warfare intelligence
CFA — covering force area
CFFZ — call for fire zone
CFL — coordinated fire line
CFZ — critical friendly zone
CG — commanding general
cgo — cargo
CGy — centigray
chem — chemical
CHEMWARN — chemical warning
ci — counterintelligence
CID — Criminal Investigation Division
CIMIC — civil military cooperation
CINC — commander in chief
CIR — critical information requirements
CMD — collection, management, and dissemination
CMOC — civil military operations center
co — company
COA — course of action
CofS — chief of staff
COLT — combat operation laser team
COMINT — communications intelligence
COMJTF — commander, joint task force
COMMZ — communications zone
COMSEC — communications security
CONOPS — continuous operations
CONPLAN — concept plan
CONUS — continental United States
COSCOM — corps support command
CP — command post
CPX — command post exercise
CS — combat support
CSB — corps support battalion
CSE — combat support equipment
CSM — command sergeant major
CSS — combat service support
CW — chemical weapons
CWC — chemical weapons convention
CZ — combat zone
DA — Department of the Army
DACG — departure airfield control group
DAO — defense attache office
DAP — decontaminating apparatus
DEA — Drug Enforcement Agency
decon — decontamination
demo — demonstration
det — detachment
DF — direction finding
DFCP — DISCOM forward command post
DFSCOORD — deputy fire support coordinator
DISCOM — division support command
div — division
DIVARTY — division artillery
DMMC — division materiel management center
DMMO — division materiel management office

DMOC — division medical operations center	F — Fahrenheit
DMSO — division medical supply officer	FA — field artillery
DOD — Department of Defense	FAA — forward assembly area
DOS — days of supply	FAAD — forward area air defense
DP — decision point	FAIO — field artillery intelligence officer
DPICM — dual-purpose improved conventional munitions	FARP — forward arming and refueling point
DRA — division rear area	FASCAM — family of scatterable mines
DRB — division ready brigade	fax — facsimile
DRF — division ready force	FCC — flight coordination center
DS — direct support	FCO — federal control officer
DSA — division support area	FDC — fire direction center
DST — division support template	FEBA — forward edge of battle area
DTG — date-time group	FEMA — Federal Emergency Management Agency
DTO — division transportation officer	FFA — free fire area
DZ — drop zone	FFIR — friendly forces information requirements
EA — engagement area	FIST — fire support team
EAC — echelons above corps	FLIR — forward looking infrared
EAD — echelons above division	PLO — fighter liaison officer
ECCM — electronic counter-countermeasures	FLOT — forward line of own troops
ECM — electronic countermeasures	FM — field manual; frequency modulated
EEFI — essential elements of friendly information	ft — foot, feet
EEI — essential elements of information	FORSCOM — US Army Forces Command
EEP — embassy evacuation plan	FRAGO — fragmentary order
elec — electric, electrical	FS — fire support
ELINT — electronic intelligence	FSB — forward support battalion
en — enemy	FSCL — fire support coordination line
enr — engineer	FSCOORD — fire support coordinator
EOC — emergency operations center	FSE — fire support element
EOD — explosive ordnance disposal	FSMC — forward support medical company
EPB — electronic preparation of the battlefield	FSO — fire support officer
EPW — enemy prisoner of war	FSOP — field standing operating procedures
ESF — emergency support function	FTX — field training exercise
ESM — electronic support measures	G — green
EW — electronic warfare	G1 — assistant chief of staff, G1 (personnel)
EWL — engineer work line	G2 — assistant chief of staff, G2 (intelligence)
EWO — electronic warfare officer	G3 — assistant chief of staff, G3 (operations and plans)
EWSM — electronic warfare support measures	G4 — assistant chief of staff, G4 (logistics)
exec — executive	G5 — assistant chief of staff, G5 (civil affairs)
EZ — extraction zone	gal — gallon

gp — group	ID(L) — light infantry division
GPS — global positioning systems	IDAD — internal defense and development
GRREG — graves registration	IEW — intelligence and electronic warfare
GS — general support	IEWSE — intelligence and electronic warfare support element
GSE — general support element	IFF — identification, friend or foe
GSR — general support reinforcing; ground surveillance radar	IFV — infantry fighting vehicle
GTC — ground tactical commander	IG — inspector general
Guardrail — special electronic mission aircraft	IMINT — imagery intelligence
HAHO — high altitude, high opening	inf — infantry
HALO — high altitude, low opening	intel — intelligence
HD — heavy drop	IP — initial point
HE — high explosive	IPAO — intelligence preparation of the area of operations
hel — helicopter	IPB — intelligence preparation of the battlefield
HEMTT — heavy expanded mobility tactical truck	IPW — prisoner of war interrogation
HEPI — heavy equipment point of impact	IR — information requirements
HEP-T — high explosive plastic tracer	ISB — intermediate staging base
HET — heavy equipment transporter	ITV — improved TOW vehicle
HF — high frequency	JAAP — joint airborne advance party
HHB — headquarters and headquarters battery	JAAT — joint air attack team
HHC — headquarters and headquarters company	JAG — judge advocate general
HHT — headquarters and headquarters troop	JCS — joint chiefs of staff
HIDACZ — high-density airspace control zone	JIC — joint information committee
HIMAD — high-to-medium-altitude air defense	JOPES — joint operations planning system
HLZ — helicopter landing zone	JSEAD — joint suppression of enemy air defense
HMMWV — high mobility multipurpose wheeled vehicle	JSOC — joint special operations command
HN — host nation	JSOTF — joint special operations task force
hp — horsepower	JTF — joint task force
HPT — high payoff target	JTF-LA — Joint Task Force-Los Angeles
HPTL — high payoff target list	KEK — key encryption key
HQ — headquarters	kHz — kilohertz
hr — hour	KIA — killed in action
HRPT — highway regulating point team	km — kilometer
HSS — health service support	kmph — kilometers per hour
HUMINT — human intelligence	kt — kiloton
HVT — high value target	LAPES — low altitude parachute extraction system
I&S — interrogation and surveillance	LAW — light antitank weapon
ICM — improved conventional munitions	lb — pound
ID — identification	LC — line of contact

LCE — load-carrying equipment	MEDEVAC — medical evacuation
LCM — landing craft, mechanized	METL — mission essential task list
LCU — landing craft, utility	METT-T — mission, enemy, terrain, troops, and time available
LD — line of departure	METT-T-P — METT-T plus political factors
LEA — Law Enforcement Agency	MG — machine gun
LLTR — low-level transit route	MGz — megahertz
LO — liaison officer	MI — military intelligence
LOB — line of bearing	MIA — missing in action
loc — location	MIJI — meaoning, intrusion, jamming and interference
LOC — lines of communication	MLRS — multiple launch rocket system
LOGPAC — logistics package	mm — millimeter
LOGSEC — logistics security	MMC — materiel management center
LOS — line of sight	MOG — minimum on ground
LOS-R — line-of-sight rear	MOGAS — motor gasoline
LP — listening post	MOPP — mission-oriented protective posture
LRF — laser ranger finder	MORTREP — mortar report
LRS — long-range surveillance	MOS — military occupational specialty
LRSD — long-range surveillance detachment	MOUT — military operations on urbanized terrain
LRSU — long-range surveillance unit	MP — military police
LSA — life support area	mph — miles per hour
LSC — life support center	MRE — meals ready to eat
LSD — landing ship, docks	MRL — multiple rocket launcher
LSDIS — light and special division interim sensor	MRR — minimum risk route; motorized rifle regiment
LST — landing ship, tanks	MSB — main support battalion
lt — light	MSC — major subordinate command
LTACFIRE — lightweight tactical tire direction system	MSE — mobile subscriber equipment
LZ — landing zone	MSMC — main support medical company
m — meter	MSR — main supply route
MA — mortuary affairs	MTF — medical treatment facility
M/S — mobility and survivability	MTOE — modified tables of organization and equipment
MACG — marshaling area control group	MTP — mission training plan
MACOM — major Army command	NAI — named area of interest
maint — maintenance	NAPP — nerve agent pretreatment pyridostigmine
MANPAD — man-portable air defense	NATO — North Atlantic Treaty Organization
MBA — main battle area	NAVAID — navigational aid
MCO — movements control office (r)	NBC — nuclear, biological, and chemical
MCOO — modified combined obstacle overlay	
MCS — maneuver control system	
med — medical; medium	

NCA — National Command Authorities
NCO — noncommissioned officer
NCS — net control station
NEO — noncombatant evacuation operation
NFA — no fire area
NFL — no fire line
NGF — naval gun fire
NLT — not later than
no — number
NUCWARN — nuclear warning
NVD — night vision device
obj — objective
OCONUS — outside continental United States
OFA — obstacle free area
OIC — officer in charge
OMG — operational maneuver group
OP — observation post
OPCON — operational control
OPLAN — operation plan
opns — operations
OPORD — operation order
OPSEC — operations security
ops — operations
PA — public affairs
PAC — personnel administration center
PAO — public affairs office (r)
PERINTREP — periodic intelligence report
PIR — priority intelligence requirement
PL — phase line
pit — platoon
PM — provost marshal
PMO — provost marshal office
POC — point of contact
POL — petroleum, oils, and lubricants
POM — preparation for overseas movement
PP — passage point
PPI — personnel point of impact
ppm — parts per million
proj — project
PSC — personnel support company
PSYOP — psychological operations
PZ — pickup zone
Quickfix — tactical heliborne communications intercept, direction finding, and electronic countermeasures system
Quicklook — airborne noncommunications emitter detector
R — reinforcing/red
RAA — rear assembly area
RAAM — remote antiarmor mine
RADAR — radio detection and ranging
RAGS — regimental artillery group
RAP — rocket-assisted projectile
RCU — remote control unit
rd — round
rec — recorder
REC — radio electronic combat (Soviet)
recon — reconnaissance
REDCON — readiness condition
REMA B — remote marshaling base
REMBASS — remotely monitored battlefield sensor system
retrans — retransmission
RFA — restrictive fire area
RFI — request for information
RFL — restrictive fire line
RKV — rekeying variable
ROC — rear operations center
ROE — rules of engagement
ROM — refuel on the move
ROWPU — reverse osmosis water purification unit
ROZ — restricted operations zone
RP — release point
RPV — remotely piloted vehicle
R&S — reconnaissance and surveillance
RSL — remote spring launch
RSTA — reconnaissance, surveillance, and target acquisition
RTO — rail transportation officer
S1 — adjutant

- S2** — intelligence officer
S3 — operations and training officer
S4 — supply officer
S5 — civil affairs officer
SAAFR — standard use Army aircraft flight route
SAR — search and rescue
SCI — sensitive compartmented information
SEAD — suppression of enemy air defenses
sec — section
SEE — small emplacement excavator
semitrl — semitrailer
SERE — survival, evasion, resistance, and escape
7thID(L) — 7th Infantry Division (Light)
SF — Special Forces
SGS — secretary of the general staff
SHORAD — short-range air defense
SICPS — standardized integrated command post system
sig — signal
SIGINT — signal intelligence
SINCGARS — single channel ground and airborne radio system
SITREP — situation report
SJA — staff judge advocate
SLAR — side-looking airborne radar
smk — smoke
SOC — special operations command
SOCCE — special operations command and control elements
SOF — special operations forces
SOI — signal operation instructions
SOP — standing operating procedure
SP — start point; strongpoint; self-propelled
SPOTREP — spot report
sqd — squad
sqdn — squadron
SR — supply route
S&S — supply and service
STANAG — standardization agreement
SVML — standard vehicle missile launcher
SWO — staff weather officer
SYSCON — systems control
T — towed
TA — theater army
TAA — tactical assembly area
tac — tactical
TACAIR — tactical air
TAC CP — tactical command post
TAC FIRE — tactical fire direction system
TACON — tactical control
TACP — tactical air control party
TACS — tactical air control system
TACSAT — tactical satellite
TAI — target area of interest
TALO — tactical airlift liaison officer
TCAE — technical control and analysis element
TCF — tactical combat force
TCP — traffic control point
TDA — tables of distribution and allowances
TEK — transmission encryption key
TF — task force
THREATCON — threat condition
TIRS — terrain index reference system
tm — team
TM — technical manual
TMT — transportation motor transport
TOC — tactical operation center
TOE — table(s) of organization and equipment
topo — topographic; topography
TOR — terms of reference
TOT — time on target
TOW — tube-launched, optically tracked, wire-guided
TPL — time phase line
TRADOC — US Army Training and Doctrine Command
TRP — target reference point
TSOP — tactical standing operating procedure
TVA — target value analysis
UAV — unmanned aerial vehicle
UBL — unit basic load

UCMJ — Uniform Code of Military Justice

UHF — ultra high frequency

UMR — unit manning report

UN — United Nations

US — United States

USAF — United States Air Force

USG — US government

USMC — United States Marine Corps

USPS — United States Postal Service

UTM — universal transverse mercator

VFR — visual flight rules

VHF — very high frequency

VIP — very important person

V/S — Vulcan/Stinger

W — wheeled

WCS — weapons control status

WETM — weather team

WFZ — weapons free zone

WIA — wounded in action

WO — warning order

WP — white phosphorous

WX — weather

WXFCST — weather forecast

XO — executive officer

REFERENCES

READINGS RECOMMENDED

These readings contain relevant supplemental information.

- AR 600-20. *Army Command Policy*. 30 March 1988
- FM 1-100. *Doctrinal Principals for Army Aviation in Combat Operations*, 28 February 1989
- FM 1-103. *Airspace Management and Army Air Traffic in a Combat Zone*. 30 December 1981
- FM 1-116. *Tactics, Techniques, and Procedures for the Air Cavalry/Reconnaissance Troop*. 20 February 1991
- FM 3-3. *Chemical and Biological Contamination Avoidance*. 16 November 1992
- FM 3-4. *NBC Protection*. 29 May 1992
- FM 3-5. *NBC Decontamination*. 23 July 1992
- FM 3-7. *NBC Handbook*, 27 September 1990
- FM 3-11. *Flame Field Expedients*. 19 September 1990
- FM 3-50. *Smoke Operations*, 4 December 1990
- FM 3-100. *NBC Defense, Chemical Warfare, Smoke, and Flame Operations*. 28 May 1991.
- FM 5-34. *Engineer Field Data*, 14 September 1987
- FM 5-36. *Route Reconnaissance and Classification*, 10 May 1985
- FM 5-71-100. *Division Engineer Combat Operations*. 22 April 1993
- FM 5-100. *Engineer Combat Operations*. 22 November 1988
- FM 5-101. *Mobility*. 23 January 1985
- FM 5-102. *Countermobility*. 14 March 1985
- FM 5-103. *Survivability*. 10 June 1985
- FM 5-114. *Engineer Operations Short of War*. 13 July 1992
- FM 5-250. *Explosives and Demolitions*. 15 June 1992
- FM 6-20. *Fire Support in the Airland Battle*. 17 May 1988
- FM 6-20-1. *Tactics, Techniques, and Procedures for the Field Artillery Cannon Battalion*. 29 November 1990
- FM 6-20-2. *Tactics, Techniques, and Procedures for Corps Artillery, Division Artillery, and Field Artillery Brigade Headquarters*. 7 January 1993
- FM 6-20-10. *Tactics, Techniques, and Procedures for the Targeting Process*. 29 March 1990
- FM 6-20-20. *Tactics, Techniques, and Procedures for Fire Support at Battalion Task Force and Below*. 27 December 1991
- FM 6-20-30. *Tactics, Techniques, and Procedures for Fire Support for Corps and Division Operations*. 18 October 1989
- FM 6-20-50. *Tactics, Techniques, and Procedures for Fire Support for Brigade Operations (Light)*. 5 January 1990.
- FM 6-60. *Multiple Launch Rocket System (MLRS) Operations*. 16 September 1992
- FM 6-121. *Tactics, Techniques, and Procedures for Field Artillery Target Acquisition*. 25 September 1990
- FM 7-8. *Infantry Rifle Platoon and Squad*. 22 April 1992
- FM 7-10. *The Infantry Rifle Company*. 14 December 1990
- FM 7-20. *The Infantry Battalion*. 6 April 1992
- FM 7-30. *Infantry, Airborne and AirAssault Brigade Operations*, 24 April 1981
- FM 7-90. *Tactical Employment of Mortars*. 9 October 1992
- FM 7-91. *Tactical Employment of Antiarmor Platoons, Companies, and Battalions*. 30 September 1987
- FM 7-92. *The Infantry Reconnaissance Platoon and Squad*. 23 December 1992

- FM 7-93. *Long Range Surveillance Unit Operations*. 9 June 1987
- FM 7-98. *Operations in a Low-Intensity Conflict*. 19 October 1992
- FM 8-10. *Health Service Support in a Theater of Operations*. 1 March 1991
- FM 8-10-3. *Division Medical Operations Center*. 1 March 1991
- FM 8-10-4. *Medical Platoon Leaders' Handbook—Tactics, Techniques, and Procedures*. 16 November 1990
- FM 8-10-5. *Brigade and Division Surgeons' Handbook, Tactics, Techniques, and Procedures*, 10 June 1991
- FM 8-10-6. *Medical Evacuation in a Theater of Operations*. 31 October 1991
- FM 8-10-7. *Health Service Support in an NBC Environment*. (Approved Final Draft 10 February 1993)
- FM 8-15. *Medical Support in Divisions, Separate Brigades, and the Armored Cavalry Regiment*. 21 September 1972
- FM 8-42. *Medical Operations in Low-Intensity Conflict*. 4 December 1990
- FM 8-55. *Planning for Health Service Support*. 15 February 1985
- FM 10-63-1. *Graves Registration Handbook*. 17 July 1986
- FM 11-38. *MSE System Management and Control*. 4 April 1991
- FM 11-41. *Signal Support: Echelons Corps and Below (ECB)*. 18 December 1991
- FM 12-6. *Personnel Doctrine*. 23 August 1989
- FM 12-50. *U.S. Army Bands*. 6 September 1991
- FM 14-7. *Finance Operations*. 9 October 1989
- FM 16-1. *Religious Support Doctrine*. 27 November 1989
- FM 19-1. *Military Police Support for the AirLand Battle*. 23 May 1988
- FM 19-10. *Military Police Law and Order Operations*. 30 September 1987
- FM 19-15. *Civil Disturbances*. 25 November 1985
- FM 19-40. *Enemy Prisoners of War, Civilian Internees and Detained Persons*. 27 February 1976
- FM 20-12. *Amphibious Embarkation*. 11 June 1987
- FM 21-10. *Field Hygiene and Sanitation*. 22 November 1988
- FM 21-10-1. *Unit Field Sanitation Team*. 1 October 1989
- FM 21-11. *First Aid for Soldiers*. 27 October 1988
- FM 21-18. *Foot Marches*. 1 June 1990
- FM 22-9. *Soldier Performance in Continuous Operations*. 12 December 1991
- FM 22-100. *Military Leadership*. 31 July 1990
- FM 22-103. *Leadership and Command at Senior Levels*. 21 June 1987
- FM 24-1. *Signal Support in the AirLand Battle*. 15 October 1990
- FM 26-2. *Management of Stress in Army Operations*. 29 August 1986
- FM 27-1. *Legal Guide for Commanders*. 13 January 1992
- FM 31-12. *Army Forces in Amphibious Operations*. 28 March 1961
- FM 31-70. *Basic Cold Weather Manual*. 12 April 1968
- FM 31-71. *Northern Operations*. 21 June 1971
- FM 33-1. *Psychological Operations*. 31 July 1987
- FM 34-1. *Intelligence and Electronic Warfare Operations*. 2 July 1987
- FM 34-2. *Collection Management*. 20 October 1990
- FM 34-3. *Intelligence Analysis*. 15 March 1990
- FM 34-8. *Combat Commander's Handbook on Intelligence*. 28 September 1992
- FM 34-10. *Division Intelligence and Electronic Warfare Operations* 25 November 1986
- FM 34-130. *Intelligence Preparation of the Battlefield*. 23 May 1989

- FM 41-10. *Civil Affairs Operations*, 11 January 1993
- FM 44-3. *Air Defense Artillery Employment, Chaparral/Vulcan/Stinger*. 15 June 1984
- FM 44-100. *US Army Air Defense Operations*. 22 November 1988
- FM 55-2. *Division Transportation Operations*. 31 January 1985
- FM 55-9. *Unit Air Movement Planning*. 31 August 1981
- FM 55-10. *Movement Control in a Theater of Operations*. 8 December 1992
- FM 63-2. *Division Support Command, Armored, Infantry, and Mechanized Infantry Division*. 20 May 1991
- FM 63-2-1. *Division Support Command, Light Infantry, Airborne, and Air Assault Divisions*. 16 November 1992
- FM 63-6. *Combat Service Support in Low-Intensity Conflict*. 21 January 1992
- FM 63-20. *Forward Support Battalion*. 26 February 1990
- FM 63-21. *Main Support Battalion*. 7 August 1990
- FM 71-100. *Division Operations*. 16 June 1990
- FM 90-2. *Battlefield Deception*. 3 October 1988
- FM 90-3. *Desert Operations*. 19 August 1977
- FM 90-4. *Air Assault Operations*. 16 March 1987
- FM 90-5. *Jungle Operations*. 16 August 1982
- FM 90-6. *Mountain Operations*. 30 June 1980
- FM 90-8. *Counter guerrilla Operations*. 29 August 1986
- FM 90-10. *Military Operations on Urbanized Terrain (MOUT)*. 15 August 1979
- FM 90-10-1. *An Infantryman's Guide to Combat in Built-up Areas*. 12 May 1993
- FM 90-13. *River Crossing Operations*. 30 September 1992
- FM 90-14. *Rear Battle*. 10 June 1985
- FM 90-15. *Multi-Service Procedures for Joint Suppression of the Enemy Air Defenses*. 19 June 1990
- FM 90-26. *Airborne Operations*. 18 December 1990
- FM 100-5. *Operations*. 14 June 1993
- FM 100-9. *Reconstitution*. 13 January 1992
- FM 100-10. *Combat Service Support*. 18 February 1988
- FM 100-15. *Corps Operations*. 13 September 1989
- FM 100-17. *Mobilization, Deployment, Redeployment, Demobilization*. 28 October 1992
- FM 100-20. *Military Operations in Low-Intensity Conflict*. 5 December 1990
- FM 100-25. *Army Special Operations Forces*. 12 December 1991
- FM 100-26. *The Army Air-Ground Operations System*. 30 March 1973
- FM 100-27. *USA/USAF Doctrine for Joint Airborne and Tactical Airlift Operations (AFM2-50)*. 31 January 1985
- FM 101-5. *Staff Organization and Operations*. 25 May 1984
- FM 101-5-1. *Operational Terms and Symbols*. 21 October 1985
- FM 101-10-1/1. *Staff Officer's Field Manual Organizational, Technical, and Logistical Data (VOL 1)*. 7 October 1987
- FM 101-10-1/2. *Staff Officer's Field Manual Organizational, Technical, and Logistical Data Planning Factors (VOL 2)*. 7 October 1987
- FM 701-58. *Planning Logistics Support for Military Operations*. 27 May 1987

DOCUMENT NEEDED

This document must be available to the intended users of this publication.

DA Form 2028. *Recommended Changes to Publications and Blank Forms*. February 1974

DOCUMENTS TO BE PUBLISHED

These documents also contain relevant supplemental information. The preparing agencies of the documents are given.

Joint Publication 3.02. *Joint Doctrine for Amphibious Operations* (Final Draft April 1991)

FM 3-13. *Riot Control Agents and Herbicides* (U.S. Army Chemical School, ATTN: ATZN-CM-NF, Fort McClellan, AL 36205-5020)

FM 3-50-1. *Smoke Unit Operations* (U.S. Army Chemical School, ATTN: ATZN-CM-NF, Fort McClellan, AL 36205-5020)

FM 5-7-30. *Brigade Engineer and Engineer Company Operations* (U.S. Army Engineer School, ATTN: ATSE-TDM-P, Fort Leonard Wood, MO 65473-6650)

FM 5-71-2. *Task Force Engineer and Engineer Company Operations* (U.S. Army Engineer School, ATTN: ATSE-TDM-P, Fort Leonard Wood, MO 65473-6650)

FM 11-54. *Satellite Operations (Multichannel)* (U.S. Army Signal School, ATTN: ATZH-DTL, Fort Gordon, GA 30905-5075)

FM 11-58. *Tactical Data Systems and Interfaces* (U.S. Army Signal School, ATTN: ATZH-DTL, Fort Gordon, GA 30905-5075)

FM 11-71. *Network Management* (U.S. Army Signal School, ATTN: ATZH-DTL, Fort Gordon, GA 30905-5075)

FM 11-73. *Information Security* (U.S. Army Signal School, ATTN: ATZL-DTL, Fort Gordon, GA 30905-5075)

FM 11-75. *Battlefield Information Services* (U.S. Army Signal School, ATTN: ATZL-DTL, Fort Gordon, GA 30905-5075)

FM 17-18. *Light Armored Operations* (U.S. Army Armor School, ATTN: ATZK-DS, Fort Knox, KY 40121-5000)

FM 17-95-30. *Light Division Cavalry Squadron* (U.S. Army Armor School, ATTN: ATZK-DS, Fort Knox, KY 40121-5000)

FM 24-10. *Signal Operations Doctrine* (U.S. Army Signal School, ATTN: ATZL-DTL, Fort Gordon, GA 30905-5075)

FM 34-5. *Intelligence Collection Operations*, (U.S. Army Intelligence Center, ATTN: ATZS-TDL-D, Fort Huachuca, AZ 85613-6000)

FM 90-11. *Winter Operations* (U.S. Army Combined Arms Command, ATTN: ATZL-SWW-L, Fort Leavenworth, KS 66027-6900)

FM 90-29. *Noncombatant Evacuation Operations* (U.S. Army Combined Arms Command, ATTN: ATZL-SWW-L, Fort Leavenworth, KS 66027-6900)

FM 100-19. *Military Assistance to Civilian Authorities* (Commander, HQ TRADOC, ATTN: ATDO-D, Fort Monroe, VA 23651)

INDEX

A

- A²C², in concurrent operations**, 5-42
 airspace control measures, 5-42 through 5-48, 5-49
 TAC CP functions, 5-50
 main CP functions, 5-50, 5-51
 rear CP functions, 5-51
 requirements for, 5-51, 5-52
 in battle, 5-53
- A²C² element, assault CP**, 2-86
- A²C² element, main CP**
 described, 2-43, 2-44
 vehicle and personnel, 2-44
 air defense coordination section, 2-45
 aviation brigade section, 2-46
 Air Force tactical air control party, 2-46, 2-47
 operating procedures, A-36, A-37
- ADC-M, TAC CP**, 2-22, 2-23
 equipment and personnel, 2-22
- ADC-S, as rear operations commander**, 2-63, 5-1
- ADSO element**
 described, 2-51, 2-52
 equipment and personnel, 2-51
 rear CP, 2-68
- agility**, iv
- air assault division**
 described, 1-1
 personnel and equipment, 1-2
- air assault operations**, 7-28
 command and control, 7-28, 7-29
 planning steps, 7-29 through 7-31
 planning matrix, 7-33
- airborne infantry division**
 described, 1-3, 1-4
 personnel and equipment, 1-3
 task organization, 6-22
- airborne operations**, 7-34
 ground tactical plan, 7-34 through 7-41, 7-42
 landing plan, 7-42 through 7-48, 7-49
 air movement plan, 7-49, 7-50
 marshaling plan, 7-50 through 7-53, 7-54
- air corridor**, 5-48, 5-49
- air defense**
 in defensive covering force, 5-26
 operating procedures, A-51, A-52
- air defense artillery, operating procedures**, A-34 through A-36
- air defense coordination section**, 2-45
- Air Force tactical air control party**, 2-46, 2-47
- air liaison officer**, 2-47, 5-52
- air mission brief, for air assault operations**, 7-32
- airmobility, compared to air assault operations**, 1-1
- air movement plan**
 for air assault operations, 7-31
 for airborne operations, 7-49, 7-50
- airspace control measures, division**
 coordinating altitude, 5-43, 5-44
 weapons free zone, 5-43, 5-45
 high-density airspace control zone, 5-43, 5-45
 restricted operations zone, 5-46
 minimum risk route, 5-46
 low-level transit route, 5-46, 5-47
- air traffic control center, and A²C²**, 2-43, 2-44
- air traffic service, and A²C²**, 2-43
- alarm, information exchange mode**, 2-6
- all source production section**, 2-58, 2-59
 equipment and personnel, 2-58
- alternate CP**, 2-3, 2-4, A-2
- amphibious operations**, 8-10, 8-11
 operations ashore, 8-11, 8-12, 8-13
 beachheads and landing areas, 8-13, 8-14, 8-15
 unit considerations, 8-15 through 8-19, 8-20
- approach march, example of**, 3-16 through 3-21
 BOS synchronization, 3-16 through 3-20, 3-21
 task organization, 3-18
- area damage control, division rear area**, 5-11, 5-12
- area defense**, 4-1. *See also* defense in sector, terrain retention, example of
- ARFOR headquarters, division as**, 6-1, 6-14
- armored-light operations**
 employment considerations, 7-62, 7-63
 planning considerations, 7-64, 7-65, 7-66
 tactical mobility, 7-66, 7-67
 tactical employment, 7-67
 unit armored systems, 7-69 through 7-79
- Army operations tenets**, iv

A

as required reports, A-71, A-87 through A-94, A-95

assault command post

described, 2-80, 2-82

elements of

command center, 2-82

plans, 2-83

G3 operations, 2-83, 2-84

G2 operations, 2-84, 2-85

fire support element, 2-85

A²C², 2-86

G1, 2-86, 2-87

G4, 2-86, 2-87

role in conflict, 6-17

assembly area

occupation of, A-24, A-25

in airborne operations, 7-60, 7-61, 7-62

attachment/detachment procedures, A-52, A-53, A-54

attack guidance, in target development

attack parameters, 5-33

matrix, 5-34

attacks and raids, 6-18

augmentation

for light infantry division, 1-1

rear CP, by reserve components, 2-78, 2-81

division, as ARFOR headquarters, 6-1

aviation brigade section, 2-46

B

backbrief rehearsal, 2-12

base cluster, in division rear area, 5-5, 5-6

base cluster defense, 5-8, 5-9

base cluster operations center

operation section as, 5-6

tasks of, 5-9

base configuration, in division rear area, 5-5

base defense force, 5-7, 5-8

base defense operations, 6-19

base defense operations center, 5-8, 5-9

base defense plan, division rear area, 5-13, 5-14, 5-15

blue reports. See **reports, operations**

breakout from encirclement

described, 7-18, 7-19

BOS synchronization, 7-18 through 7-22, 7-23

task organization, 7-21

C

call signs, for enemy contact, A-20, A-21

campaign SEAD, 5-37

chemical weapons, deterrence of, US position, 3-1

Chemical Weapons Convention, 3-1

civil-military operating procedures, A-70

civil-military operations center, 2-70, A-70

code words, communication, A-7, A-8, A-9

cold weather operations

cold weather considerations, 8-20 through 8-22

operations planning, 8-23, 8-24

color code

in information display, 2-7

for warning procedures, A-19

combat, preparation for

personal combat equipment checks, A-25, A-26, A-27

personal uniform and equipment checks, A-27

individual checks, A-28, A-29

vehicle checks, A-30, A-31

combat multiplier

continuous operations, 2-12, 2-13

deception as, 5-58

combat service support cell, rear CP

described, 2-70

elements of

logistics, 2-70, 2-71

G1 personnel section, 2-71, 2-72

G1 support, 2-71 through 2-74, 2-75

staff judge advocate section, 2-75, 2-76

public affairs section, 2-75, 2-76

division surgeon, 2-75, 2-77

inspector general, 2-77, 2-79

division band, 2-78, 2-80

division chaplain, 2-78, 2-79

command. See also **command and control**

definition of, 2-1

command cell, main CP

command center, 2-31 through 2-36, 2-37

command group, 2-37

command center

equipment and personnel, main CP, 2-33

assault CP, 2-82, 2-83

command and control

and information management, 2-5 through 2-7, 2-8

in continuous operation, 2-14

while displacing, 2-18

developing technology, 9-1

commander's critical information requirements, 2-6

C

commanders situation report, and maneuver information, 2-7, 2-8

command post operations

- alternate CPs, 2-3, 2-4
- information management, 2-5 through 2-7, 2-8
- transition operations, planning of, 2-9
- parallel planning, 2-9, 2-10
- rehearsals, 2-10 through 2-12
- continuous operations, 2-12 through 2-14, 2-15
- liaison operations, 2-15 through 2-17, 2-18
- CP displacement, 2-18, 2-19
- CP security, 2-19

command posts. *See also* TAC CP; main CP; rear CP

- guidelines for, 2-1
- common functions, 2-2, 2-3
- personnel in, 2-4, 2-5
- and maneuver information, 2-7, 2-8
- and intelligence information, 2-8
- displacement of, 2-18, 2-19
- security of, 2-19
- facilities, 2-19, 2-20

communication

- code words, A-7, A-8, A-9
- hand and arm signals, A-14 through A-19
- call signs, secure, A-20, A-21

complementary SEAD, 5-38

concurrent operations

- described, 5-1
- rear operations in, 5-1 through 5-14, 5-15
- deep operations in, 5-15 through 5-20, 5-21
- reconnaissance operations in, 5-20 through 5-22, 5-23
- security operations in, 5-23 through 5-29
- targeting in, 5-30 through 5-36
- SEAD in, 5-37 through 5-41, 5-42
- A²C² in, 5-42 through 5-53
- electronic warfare in, 5-54 through 5-57, 5-58
- deception operations in, 5-58 through 5-61
- counterfire in, 5-62 through 5-66

conflict

- described, 6-1
- operational planning, 6-15, 6-16, 6-17
- types of operations, 6-17, 6-18, 6-19
- scenario, 6-19 through 6-23, 6-24

conflict scenario, 6-19, 6-20

- conduct of operations, 6-21 through 6-24
- task organizations, 6-22

contingency operations, stages of, 6-1

continuous operations, 2-12 through 2-14, 2-15

shift changeover, 2-14, 2-15

control. *See also* command and control

definition of, 2-1

coordinating altitude, 5-43, 5-44

counterfire, 5-62 through 5-66

counterguerrilla operations, 6-18, 6-19

counterreconnaissance, 5-29, 5-30

critical skills, and continuous operations, 2-13

CSM, role in CPs, 2-5

culminating point, 3-43, 4-36

D

deception operations, in concurrent operations, 5-58 through 5-61

decide phase, in targeting

- development of HPTL, 5-32
- target selection standards, 5-33
- attack guidance, 5-33

deep operations, in concurrent operations, 5-15 through 5-20, 5-21

synchronization matrix, 5-16, 5-17

deep operations, offensive

focus of, 3-1

defense in depth, 4-1. *See also* defense in sector, defense in depth, example of

defense in sector

- terrain retention, example of
 - described 4-3
 - BOS synchronization, 4-2 through 4-12, 4-13
 - task organization, 4-3
- defense in depth, example of
 - described, 4-13 through 4-15, 4-16
 - BOS synchronization, 4-16 through 4-31, 4-32
 - task organization, 4-18

defensive covering forces, 5-26

defensive operations

- described, 4- I
- fundamentals of, 4-1, 4-2
- examples of
 - defense in sector, terrain retention, 4-2 through 4-12, 4-13
 - defense in sector, defense in depth, 4-13 through 4-31, 4-32
 - mobile defense, 4-32 through 4-35, 4-36
- transition to, 4-36

D

deliberate attack, example of
 described, 3-2 through 3-3
 BOS synchronization, 3-3 through 3-11, 3-13
 task organization, 3-5

deliver phase, in targeting, 5-35, 5-36

deployment, air assault division, 1-3

depth, iv

desert operations
 impact of, 8-24 through 8-26, 8-27
 techniques for vehicle operations, 8-27

detect phase, in targeting, 5-34, 5-35

developing technology
 command and control, 9-1
 lethality, 9-2
 sensing, 9-2
 fire support, 9-2, 9-3
 survivability, 9-3
 human performance, 9-3, 9-4

DISCOM, role in rear operations, 5-2

DISCOM CP, collocated with rear CP, 2-61, 2-62, 2-63

displacement, command post, 2-18, 2-19, A-2

display information. See information display; operations map

DIVARTY section, fire support element, 2-48, 2-49

division band, rear CP, 2-78
 equipment and personnel, 2-80

division chaplain section, rear CP, 2-78
 equipment and personnel, 2-79

division rear area
 described, 5-1
 terrain management in, 5-3, 5-4, 5-5
 base configuration in, 5-5
 base clusters in, 5-5, 5-6

division surgeon section, rear CP, 2-75
 equipment and personnel, 2-77

division terrain team, 2-60
 equipment and personnel, 2-61

division transportation officer, in CSS cell, 2-70, 2-71

E

electronic warfare, 5-54
 planning for, 5-54, 5-55
 example of, 5-58

electronic warfare section, fire support element, 2-50, 2-51

engineer operating procedure, A-46, A-47, A-48

engineer section, fire support element, 2-49, 2-50

essential elements of friendly information, and information management, 2-6

exploitation and pursuit, example of described, 3-31, 3-32
 BOS synchronization, 3-32 through 3-35, 3-36
 task organization, 3-33

F

feedback, in deception operations, 5-61

field artillery, operating procedures, A-48 through A-50, A-51

field artillery intelligence officer, in all source production section, 2-58, 2-59

fighter liaison officer, 2-47

fire support element
 TAC CP, 2-27, 2-28
 equipment and personnel, 2-28
 assistance of main CP FSE, 2-29, 2-30
 main CP, elements of
 DIVARTY section, 2-48, 2-49
 engineer section, 2-49, 2-50
 electronic warfare section, 2-50, 2-51
 rear CP, 2-67, 2-68
 assault CP, 2-85

fire support operations map, 2-28, 2-29

flank guard, in security operations, 5-27, 5-28

follow and support operation
 described, 3-36, 3-37
 BOS synchronization, 3-37 through 3-42, 3-43
 task organization, 3-38

forward passage of lines
 described, 7-10, 7-11
 BOS synchronization, 7-10 through 7-12, 7-13

friendly forces information requirements, and information management, 2-6

full rehearsal, 2-11

G

G1, assault CP, 2-86

G1 personnel section, rear CP, 2-71 through 2-74, 2-75
 equipment and personnel, 2-72

G1 support element, rear CP, 2-71 through 2-73, 2-74
 equipment and personnel, 2-73, 2-74

G**G2 cell, main CP, elements of**

G2 operations, 2-55 through 2-57
 all source production section, 2-58, 2-59
 staff weather officer, 2-59, 2-60
 division terrain team, 2-60, 2-61

G2 intelligence element, rear CP, 2-65, 2-66, 2-67

equipment and personnel, 2-66

G2 operations element, assault CP, 2-84**G2 operations element, main CP**

described, 2-55, 2-56, 2-57
 equipment and personnel, 2-56

G2 operations element, TAC CP, 2-26, 2-27

equipment and personnel, 2-26

G3 cell, main CP, elements of

G3 operations, 2-38 through 2-41
 G3 plans, 2-42
 A²C², 2-43 through 2-46, 2-47
 tire support, 2-47 through 2-50, 2-51
 ADSO, 2-51, 2-52
 NBC element, 2-52, 2-53, 2-54

G3 operations element, assault CP, 2-83, 2-84**G3 operations element, main CP, 2-38 through 2-41**

equipment and personnel, 2-39

G3 operations element, rear CP, 2-63, 2-64

equipment and personnel, 2-64

G3 operations element, TAC CP, 2-23 through 2-25

equipment and personnel, 2-23

G3 plans element, main CP, 2-42**G4/DTO, equipment and personnel, 2-71****G4 element, assault CP, 2-86, 2-87****G4 element, rear CP. See logistics element****G5 element, rear CP, 2-68, 2-70**

equipment and personnel, 2-70

green reports. See reports, intelligence**ground tactical plan**

for air assault operations, 7-29, 7-30

for airborne operations

planning for, 7-34 through 7-39

execution of, 7-40, 7-41, 7-42

guard mission, in security operations, 5-26, 5-27**gumball charts, in TAC CP G3 operations, 2-24, 2-25****H****headquarters cell, rear CP, 2-63**

vehicle and personnel, 2-64

health service support, A-65 through A-67, A-68**heavy forces, integration procedures, A-54, A-55****high-density airspace control zone, 5-43, 5-45****high payoff target list, and targeting process, 5-18****host nation, and liaison team, 2-17****I****infiltration operation**

described, 7-23

phases of, 7-24

control measures for, 7-25, 7-26

synchronization of BOS, 7-26 through 7-27, 7-28

information display. See also operations map

map size, 2-6

means of, 2-7

maneuver information, 2-7

intelligence information, 2-8

TAC CP G3, 2-24, 2-25

TAC CP G2, 2-27

fire support element, 2-28, 2-29

main CP, 2-31

command center, 2-32 through 2-36, 2-37

air defense coordination section, 2-45

aviation brigade section, 2-46

DIVARTY section, fire support element, 2-48, 2-49

engineer section, 2-49, 2-50

ADSO element, 2-52

NBC element, 2-53, 2-54

G2 operations, main CP, 2-57

rear CP, 2-63

rear operations cell, 2-63, 2-64, 2-65

G2 intelligence element, rear CP, 2-67

fire support element, 2-67, 2-68

information, management of

modes of information exchange, 2-6

reduction of data, 2-6, 2-7

in maneuver, 2-7, 2-8

in intelligence, 2-8

in command center, main CP, 2-32

initiative, iv

I

- inspector general section, rear CP, 2-77**
 - equipment and personnel, 2-79
- intelligence information**
 - management of, 2-8
 - through ASPS, 2-58
- intelligence information, provision of**
 - G2 intelligence element, rear CP, 2-65, 2-67
- intelligence reports. *See reports, intelligence***

J

- jungle operations**
 - environment, 8-27, 8-28
 - operations planning, 8-28, 8-29
 - offensive, 8-30
 - defensive, 8-31

K

- key leader rehearsal, 2-11**

L

- landing plans**
 - for air assault operations, 7-30,7-31
 - for airborne operations, 7-42 through 7-48, 7-49
- leaders, and continuous operations, 2-13, 2-14**
- liaison, responsibility for establishing, 2-15, 2-16**
- liaison officer, 2-15, 2-16, 2-17**
 - techniques of, 2-17, 2-18
 - in command center, 2-35
 - fighter liaison officer, 2-47
 - air liaison officer, 2-47, 5-52
- liaison operations, 2-15 through 2-17, 2-18**
- liaison procedures, A-6, A-7**
- life support area, 2-78, 2-81**
- light infantry division**
 - described, 1-1
 - personnel and equipment, 1-2
 - task organization, follow-on, 6-22
- link-up operation**
 - described 7-13, 7-14
 - BOS synchronization, 7-14 through 7-17
 - operating procedures, A-32
- loading plan, for air assault operations, 7-31**
- localized SEAD, 5-37**
- lodgment operations, 6-19 through 6-24**
- logistics element, rear CP, 2-70, 2-71**
 - G4/DTO equipment and personnel, 2-71

logistics operating procedures

- reconstitution, A-55, A-56
 - supply, A-56 through A-59, A-60
 - services, A-60
 - transportation, A-61, A-62, A-63
 - health service support, A-66
- logistics reports. *See reports, logistics***
- logistics support area**
- placement of, 2-20
- low-level transit route, 5-46, 5-47**

M

- main CP**
 - role of, 2-2
 - relationship with TAC CP and rear CP, 2-1, 2-2, 2-3
 - alternate CP for, 2-3, 2-4
 - described, 2-31, 2-32
 - conjunction of, 2-32
- main CP, elements of**
 - command cell, 2-31 through 2-37
 - G3 cell. *See G3 cell, main CP, elements of*
 - G2 cell. *See G2 cell, main CP, elements of*
- maneuver information, management of 2-7, 2-8**
- maneuver and offensive operations, 3-1**
- map rehearsal, 2-12**
- marshaling plan, for airborne operations, 7-50 through 7-53,7-54**
- military operations on urban terrain**
 - role of infantry division, 8-1 through 8-4
 - defensive operations, 8-5, 8-6
 - offensive operations, 8-5 through 8-9, 8-10
- minimum risk route, 5-46**
- mobile defense, 4-1**
 - example of, 4-32 through 4-35, 4-36
 - BOS synchronization, 4-33 through 4-35, 4-36
 - task organization, 4-35
- mobility and survivability element, TAC CP, 2-30,2-31**
 - equipment and personnel, 2-30
- mobilization, in contingency operations, 6-1**
- movement, as rear operations function, 5-1, 5-2, 5-3**
- movement operations**
 - for airborne operations, 7-54
 - tactical road march, 7-54 through 7-59, 7-60

M**movement to contact operations**

- purpose of, 3-16
- approach march, example of, 3-16 through 3-20, 3-21
- search and attack, example of, 3-21 through 3-25, 3-26
- reconnaissance in force, example of, 3-26 through 3-30, 3-31

MP operations, in terrain retention, 4-12, 4-13**N****NBC element, main CP, 2-52, 2-53, 2-54**

- equipment and personnel, 2-53

NBC operating procedures, A-44, A-45, A-46**NBC reports, A-71, A-95 through A-100****NCOs**

- role in CPs, 2-5, 2-7
- and shift changes, 2-15
- in G3 operations, 2-24

NEO forces

- evacuation ground force, 6-25
- safe haven force, 6-26
- advance party, 6-26

NEO operations, 6-24, 6-25

- operational planning, 6-25, 6-26
- staff responsibilities, 6-26, 6-27, 6-28

nonpermissive NEO, 6-25**nontactical movement, 5-2****nuclear weapons, US position on, 3-1****O****offensive covering force, in security operations, 5-24, 5-25, 5-26****offensive operations**

- described, 3-1
- fundamentals of, 3-1, 3-2
- deliberate attack, example of, 3-2 through 3-12, 3-13
- penetration, example of, 3-13 through 3-15, 3-16
- movement to contact. *See* movement to contact operations
- exploitation and pursuit, example of, 3-31 through 3-35, 3-36
- follow and support, example of, 3-36 through 3-42, 3-43
- transition to, 3-43

officers. *See also* liaison officer

- role in CPs, 2-5
- and shift change, 2-15

operations journal, 2-7**operations map**

- as information display, 2-7
- TAC CP G3, 2-24, 2-25
- TAC CP G2, 2-27
- NBC, 2-53, 2-54
- G2 operations, main CP, 2-57
- rear CP, 2-63

operations other than war, described, 6-1**operations reports. *See* reports, operations****P****parallel planning, 2-9, 2-10****passage of lines, operating procedures, A-33, A-34****peace enforcement operations, 6-29, 6-30****peacekeeping operations, 6-28, 6-29****peacetime activities, 6-1, 6-2**

- planning considerations, 6-2, 6-3, 6-4
- task organization, 6-4
- force protection, 6-7
- legal consideration, 6-7
- synchronization matrix, 6-8
- integration of special operations force, 6-9
- scenario, 6-9 through 6-13

peacetime activities scenario. 6-9

- BOS synchronization, 6-10 through 6-13
- task organization, 6-11

penetration operations, example of

- described, 3-13
- BOS synchronization, 3-13 through 3-15, 3-16
- task organization for, 3-15

permissive NEO, 6-25**personnel reports. *See* reports, personnel****personnel support procedures**

- personnel, A-63, A-64
- postal, A-64, A-65
- finance, A-65
- band, A-65
- health service support, A-65 through A-67, A-68
- staff judge advocate, A-68, A-69
- public affairs, A-69
- chaplain, A-69
- inspector general, A-69
- military police, A-70, A-71

physical conditioning, and continuous operations, 2-13**pipeline, information exchange mode, 2-6**

P

planning, in CP

- transition operations, 2-9
- parallel, 2-9,2-10
- rehearsal, 2-10, 2-11

postconflict operations, 6-14,6-15

priority intelligence requirements, 2-6

provost marshal element, rear CP, 2-68

- equipment and personnel, 2-69

public affairs section, rear CP, 2-75

- equipment and personnel, 2-76

publication of orders, procedures for, A-3, A-4

R

radio rehearsal, 2-12

rear CP

- relationship with TAC and main CPs, 2-1, 2-2, 2-3

- functions of, 2-3

- alternate CP for, 2-4

- described, 2-61, 2-62, 2-63

- elements of

- headquarters cell, 2-63, 2-64

- rear operations cell, 2-63 through 2-69, 2-70

- combat service support cell, 2-70 through 2-77, 2-78

- functions of, in concurrent operations, 5-1

- role in movement, 5-2

rear guard, in security operations, 5-28

rear operations cell, rear CP

- described, 2-63

- designator of base commanders, 5-5

- and base clusters, 5-5,5-6

- and rear area security, 5-6,5-7

rear operations cell, rear CP, elements of

- G3 operations, 2-63, 2-64, 2-65

- G2 intelligence, 2-65, 2-66, 2-67

- fire support, 2-66, 2-67, 2-68

- ADSO, 2-68

- provost marshal, 2-68, 2-69

- G5, 2-68, 2-70

reciprocal liaison, 2-15

recognition techniques

- vehicle marking systems, A-10 through A-13

- hand and arm signals, A-14 through A-18, A-19

reconnaissance

- in concurrent operations, 5-20 through 5-22, 5-23

- types of, 5-21

reconnaissance in force operation, example of

- described, 3-26

- BOS synchronization, 3-26 through 3-30,3-31

- task organization, 3-28

red reports. See reports, personnel

rehearsals, CP operations

- described, 2-10

- planning considerations for, 2-10, 2-11

- types of, 2-11

- and OPSEC, 2-12

rehearsals, and marshaling operations, 7-51

relief in place operation

- described, 7-1

- BOS synchronization, 7-1 through 7-4, 7-5

- operating procedures, A-32, A-33

reports

- spot, and maneuver information, 2-7

- general information, A-70, A-71

- operations, A-71, A-74, A-75, A-76

- intelligence, A-71, A-76, A-77, A-78

- logistics, A-71, A-79 through A-85

- personnel, A-71, A-86, A-87

- as required, A-71, A-89 through A-97, A-98

- NBC, A-71, A-98 through A-100

- matrix, A-72, A-73

reserve component

- augmentation of rear CP, 2-78, 2-81

- in peacetime activities, 6-7

response forces, division rear area, 5-9, 5-10

response to threat, levels of, 5-7

restricted operations zone, 5-46

retrograde operations

- described, 7-5

- BOS synchronization, 7-5 through 7-9

- task organization, 7-7

- river crossing, 8-33,8-34

river crossing operations

- offensive, 8-29, 8-30, 8-31, 8-32

- retrograde, 8-33, 8-34

- operating procedures, A-34

S

screen, in security operations, 5-28, 5-29

SEAD operations
 categories of, 5-37, 5-38
 division, 5-38
 staff responsibilities, 5-38, 5-39, 5-40
 example of, 5-40, 5-41, 5-42

search and attack operations
 described, 3-21, 3-22
 BOS synchronization, 3-22 through 3-25, 3-26

security, command post, 2-12, 2-19
 provost marshal element, 2-68, 2-69
 rear operations function, 5-1, 5-6 through 5-14, 5-15

security operations, 4-1
 types of, in concurrent operations, 5-23
 offensive covering forces, 5-24, 5-25, 5-26
 defensive covering forces, 5-26
 guard mission, 5-26, 5-27
 flank guard, 5-27, 5-28
 rear guard, 5-28
 screen, 5-28, 5-29
 counterreconnaissance, 5-29, 5-30

security procedures, A-41
 documents, A-42
 enemy prisoner of war, A-42, A-43
 captured documents, A-43

semipermissive NEO, 6-25

shift changeover, in CPs, 2-14, 2-15

shift cycles, in CPs, A-2

shift wheel, 2-15

show of force operation, 6-17, 6-18

signal operating procedures, A-38 through A-40, A-41

situation map, in terrain management, 5-3, 5-5

sketch map rehearsal, 2-12

sleep loss, and operations, 2-13, 2-14

soldier's load, and operations, 2-13

special operations forces, in peacetime activities, 6-9

spot report, and maneuver information, 2-7

staff judge advocate, in support of G5 operations, 2-70

staff judge advocate section, rear CP, 2-75
 equipment and personnel, 2-76

staff weather officer element, 2-59, 2-60
 equipment, 2-59

staging plan, for air assault operations, 7-31

standard use Army aircraft flight route, 5-47, 5-48

succession of command, A-2

sustainment, as rear area function, 5-1, 5-2
 synchronization, iv

T

TAC CP
 relationship with main and rear CP, 2-1, 2-2, 2-3
 role of, 2-3
 alternate CP for, 2-3, 2-4
 and maneuver information, 2-7
 placement of, 2-20
 duties of, 2-20
 design of, 2-20, 2-21
 in warm mode, 2-21
 elements of
 ADC-M, 2-22, 2-23
 G3 operations, 2-23 through 2-25
 G2 operations, 2-26, 2-27
 tire support element, 2-27 through 2-29
 mobility and survivability, 2-30, 2-31

tactical combat force, division rear area, 5-10, 5-11

tactical movement, 5-2, 5-3

tactical road march, 7-54 through 7-59, 7-60
 planning for, 7-57, 7-58
 execution of, 7-58, 7-59, 7-60

tactical road movement, A-22, A-23
 standard orders of march, A-23
 route priorities, A-24

TALO, in G4 element, rear CP, 2-71

targeting
 in deep operations, 5-18, 5-19
 in concurrent operations, 5-30 through 5-36

targeting board, 5-31

targeting team, 5-18, 5-20, 5-31 through 5-33, 5-34

target selection standards, 5-33

task organization, examples of
 deliberate attack, 3-5
 approach march, 3-18
 search and attack, 3-25
 reconnaissance in force, 3-28
 exploitation and pursuit, 3-33
 follow and support, 3-38
 defense in sector, terrain retention, 4-5
 defense in sector, defend in depth, 4-18
 mobile defense, 4-35
 peacetime activities scenario, 6-9
 retrograde operation, 7-7
 breakout from encirclement, 7-21
 standard combined arms combat organization, A-12

T

terrain index reference system, A-9
terrain management, as rear area function,
5-1, 5-3 through 5-5, 5-6
terrain model rehearsal, 2-11, 2-12
**terrain retention. See defense in sector, ter-
rain retention, example of**
terrain team, division, 2-60, 2-61
threat condition, development of, A-19, A-20
training
for continuous operations, 2-13
for CP displacement, 2-18
transition operations planning, 2-9
tree, information exchange mode, 2-6
TSOP, purpose of, A-1
two-brigade division operations, 7-80
BOS synchronization, 7-80 through 7-86

U

USAF weather team, 2-59, 2-60

V

versatility, v

W

warning procedures, color codes, A-19
weapons free zone, 5-43, 5-45
weather team, 2-59, 2-60
**winter operations. See cold weather opera-
tions**

Y

yellow reports. See reports, logistics

FM 71-100-2
31 AUGUST 1993

By Order of the Secretary of the Army:

GORDON R. SULLIVAN
General, United States Army
Chief of Staff

Official:

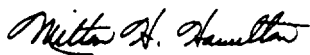
MILTON H. HAMILTON
Administrative Assistant to the
Secretary of the Army
04818

DISTRIBUTION:

Active Army, USAR, and ARNG: To be distributed in accordance with DA Form 12-11E, requirements for FM 71-100-2, Infantry Division Operations, Tactics, Techniques, and Procedures (Qty rqr block No. 5268).

PIN: 071545-000